

**Progress in Nonlinear Differential Equations
and Their Applications**



Contributions to Nonlinear Analysis

A Tribute to D.G. de Figueiredo on the Occasion of his 70th birthday

**Thierry Cazenave
David Costa
Orlando Lopes
Raúl Manásevich
Paul Rabinowitz
Bernhard Ruf
Carlos Tomei
Editors**



Birkhäuser



Progress in Nonlinear Differential Equations and Their Applications

Volume 66

Editor

Haim Brezis
Université Pierre et Marie Curie
Paris
and
Rutgers University
New Brunswick, N.J.

Editorial Board

Antonio Ambrosetti, Scuola Internazionale Superiore di Studi Avanzati, Trieste
A. Bahri, Rutgers University, New Brunswick
Felix Browder, Rutgers University, New Brunswick
Luis Cafarelli, Institute for Advanced Study, Princeton
Lawrence C. Evans, University of California, Berkeley
Mariano Giaquinta, University of Pisa
David Kinderlehrer, Carnegie-Mellon University, Pittsburgh
Sergiu Klainerman, Princeton University
Robert Kohn, New York University
P.L. Lions, University of Paris IX
Jean Mahwin, Université Catholique de Louvain
Louis Nirenberg, New York University
Lambertus Peletier, University of Leiden
Paul Rabinowitz, University of Wisconsin, Madison
John Toland, University of Bath

Contributions to Nonlinear Analysis

A Tribute to D.G. de Figueiredo
on the Occasion of his 70th Birthday

Thierry Cazenave
David Costa
Orlando Lopes
Raúl Manásevich
Paul Rabinowitz
Bernhard Ruf
Carlos Tomei
Editors

Birkhäuser
Basel · Boston · Berlin

Editors:

Thierry Cazenave
Laboratoire Jacques-Louis Lions
B.C. 187
Université Pierre et Marie Curie
4, place Jussieu
75252 Paris Cedex 05, France
e-mail: cazenave@ccr.jussieu.fr

David Costa
Department of Mathematical Sciences
University of Nevada
Las Vegas, NV 89154-4020, USA
e-mail: costa@unlv.edu

Orlando Lopes
Instituto de Matemática
UNICAMP - IMECC
Caixa Postal: 6065
13083-859 Campinas, SP, Brasil
e-mail: lopes@ime.unicamp.br

Raúl Manásevich
Departamento de Ingeniería Matemática
Facultad de Ciencias Físicas y Matemáticas
Universidad de Chile
Casilla 170, Correo 3, Santiago, Chile.
e-mail: manasevi@dim.uchile.cl

Paul Rabinowitz
University of Wisconsin-Madison
Mathematics Department
480 Lincoln Dr
Madison WI 53706-1388, USA
e-mail: rabinowi@math.wisc.edu

Bernhard Ruf
Dipartimento di Matematica
Università degli Studi
Via Saldini 50
20133 Milano, Italy
e-mail: ruf@mat.unimi.it

Carlos Tomei
Departamento de Matemática
PUC Rio
Rua Marquês de São Vicente, 225
Edifício Cardeal Leme
Gávea - Rio de Janeiro, 22453-900, Brasil
e-mail: carlos@mat.puc-rio.br

2000 Mathematics Subject Classification 35, 49, 34

A CIP catalogue record for this book is available from the Library of Congress,
Washington D.C., USA

Bibliographic information published by Die Deutsche Bibliothek
Die Deutsche Bibliothek lists this publication in the Deutsche Nationalbibliografie;
detailed bibliographic data is available in the Internet at <http://dnb.ddb.de>.

ISBN 3-7643-7149-8 Birkhäuser Verlag, Basel – Boston – Berlin

This work is subject to copyright. All rights are reserved, whether the whole or part
of the material is concerned, specifically the rights of translation, reprinting, re-use of
illustrations, broadcasting, reproduction on microfilms or in other ways, and storage in
data banks. For any kind of use whatsoever, permission from the copyright owner must
be obtained.

© 2006 Birkhäuser Verlag, P.O. Box 133, CH-4010 Basel, Switzerland
Part of Springer Science+Business Media
Printed on acid-free paper produced of chlorine-free pulp. TCF ∞
Printed in Germany

ISBN 10: 3-7643-7149-8

e-ISBN: 3-7643-7401-2

ISBN 13: 978-3-7643-7149-4

Contents

Dedication	ix
<i>J. Palis</i> On Djairo de Figueiredo. A Mathematician	xi
<i>E.A.M. Abreu, P.C. Carrião and O.H. Miyagaki</i> Remarks on a Class of Neumann Problems Involving Critical Exponents .	1
<i>C.O. Alves and M.A.S. Souto</i> Existence of Solutions for a Class of Problems in \mathbb{R}^N Involving the $p(x)$ -Laplacian	17
<i>V. Benci and D. Fortunato</i> A Unitarian Approach to Classical Electrodynamics: The Semilinear Maxwell Equations	33
<i>V. Benci, C.R. Grisanti and A.M. Micheletti</i> Existence of Solutions for the Nonlinear Schrödinger Equation with $V(\infty) = 0$	53
<i>R.C. Charão, E. Bisognin, V. Bisognin and A.F. Pazoto</i> Asymptotic Behavior of a Bernoulli–Euler Type Equation with Nonlinear Localized Damping	67
<i>L. Boccardo</i> T-minima	93
<i>S. Bolotin and P.H. Rabinowitz</i> A Note on Heteroclinic Solutions of Mountain Pass Type for a Class of Nonlinear Elliptic PDE's	105
<i>Y. Bozhkov and E. Mitidieri</i> Existence of Multiple Solutions for Quasilinear Equations via Fibering Method	115
<i>D. Castorina and F. Pacella</i> Symmetry of Solutions of a Semilinear Elliptic Problem in an Annulus	135
<i>A. Castro and J. Cossio</i> Construction of a Radial Solution to a Superlinear Dirichlet Problem that Changes Sign Exactly Once	149

<i>M.M. Cavalcanti, V.N. Domingos Cavalcanti and J.A. Soriano</i> Global Solvability and Asymptotic Stability for the Wave Equation with Nonlinear Boundary Damping and Source Term	161
<i>T. Cazenave, F. Dickstein and F.B. Weissler</i> Multiscale Asymptotic Behavior of a Solution of the Heat Equation on \mathbb{R}^N	185
<i>F.J.S.A. Corrêa and S.D.B. Menezes</i> Positive Solutions for a Class of Nonlocal Elliptic Problems	195
<i>D.G. Costa and O.H. Miyagaki</i> On a Class of Critical Elliptic Equations of Caffarelli-Kohn-Nirenberg Type	207
<i>Y. Ding and A. Szulkin</i> Existence and Number of Solutions for a Class of Semilinear Schrödinger Equations	221
<i>J.M. do Ó, S. Lorca and P. Ubilla</i> Multiparameter Elliptic Equations in Annular Domains	233
<i>C.M. Doria</i> Variational Principle for the Seiberg–Witten Equations	247
<i>P. Felmer and A. Quaas</i> Some Recent Results on Equations Involving the Pucci’s Extremal Operators	263
<i>J. Fleckinger-Pellé, J.-P. Gossez and F. de Thélin</i> Principal Eigenvalue in an Unbounded Domain and a Weighted Poincaré Inequality	283
<i>C.L. Frota and N.A. Larkin</i> Uniform Stabilization for a Hyperbolic Equation with Acoustic Boundary Conditions in Simple Connected Domains	297
<i>J.V. Goncalves and C.A. Santos</i> Some Remarks on Semilinear Resonant Elliptic Problems	313
<i>O. Kavian</i> Remarks on Regularity Theorems for Solutions to Elliptic Equations via the Ultracontractivity of the Heat Semigroup	321

<i>F. Ammar Khodja and M.M. Santos</i> 2d Ladyzhenskaya–Solonnikov Problem for Inhomogeneous Fluids	351
<i>Y.Y. Li and L. Nirenberg</i> Generalization of a Well-known Inequality	365
<i>D. Lupo, K.R. Payne and N.I. Popivanov</i> Nonexistence of Nontrivial Solutions for Supercritical Equations of Mixed Elliptic-Hyperbolic Type	371
<i>E.S. Medeiros</i> On the Shape of Least-Energy Solutions to a Quasilinear Elliptic Equation Involving Critical Sobolev Exponents	391
<i>M. Montenegro and F.O.V. de Paiva</i> A-priori Bounds and Positive Solutions to a Class of Quasilinear Elliptic Equations	407
<i>A.S. do Nascimento and R.J. de Moura</i> The Role of the Equal-Area Condition in Internal and Superficial Layered Solutions to Some Nonlinear Boundary Value Elliptic Problems	415
<i>R.H.L. Pedrosa</i> Some Recent Results Regarding Symmetry and Symmetry-breaking Properties of Optimal Composite Membranes	429
<i>A.L. Pereira and M.C. Pereira</i> Generic Simplicity for the Solutions of a Nonlinear Plate Equation	443
<i>J.D. Rossi</i> An Estimate for the Blow-up Time in Terms of the Initial Data	465
<i>B. Ruf</i> Lorentz Spaces and Nonlinear Elliptic Systems	471
<i>N.C. Saldanha and C. Tomei</i> The Topology of Critical Sets of Some Ordinary Differential Operators ..	491
<i>P.N. Srikanth and S. Santra</i> A Note on the Superlinear Ambrosetti–Prodi Type Problem in a Ball ..	505

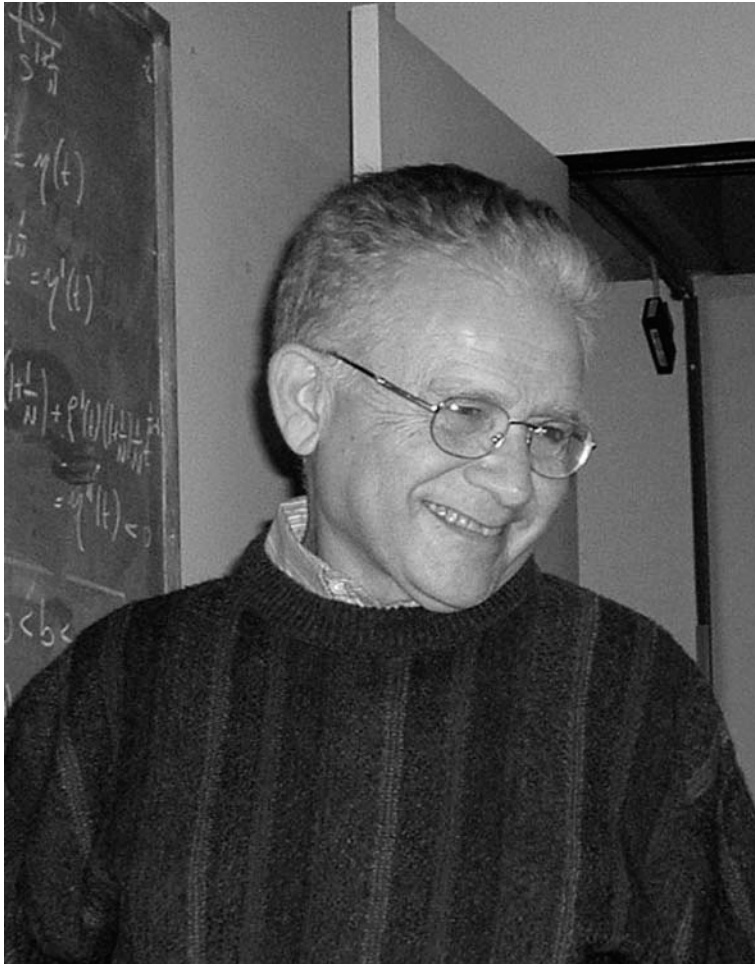

Djauro de Figueiredo

Dedication

This volume is dedicated to **Djairo G. de Figueiredo** on the occasion of his 70th birthday.

In January 2003 David Costa, Orlando Lopes and Carlos Tomei, colleagues and friends of Djairo, invited us to join the organizing committee for a *Workshop on Nonlinear Differential Equations*, sending us the following message:

Djairo's career is a remarkable example for the Brazilian community. We are proud of his mathematical achievements and his ability to develop so many successors, through systematic dedication to research, advising activities and academic orchestration. Djairo is always organizing seminars and conferences and is constantly willing to help individuals and the community. It is about time that he should enjoy a meeting without having to work for it.

How true! Of course we all accepted with great enthusiasm. The workshop took place in Campinas, June 7–11, 2004. It was a wonderful conference, with the participation of over 100 mathematicians from all over the world.

The wide range of research interests of Djairo is reflected by the articles in this volume. Through their contributions, the authors express their appreciation, gratitude and friendship to Djairo.

We are happy that another eminent Brazilian mathematician, Jacob Palis from IMPA, has accepted our invitation to give an appreciation of Djairo's warm personality and his excellent work.

The editors:

Thierry Cazenave
David Costa
Raúl Manásevich
Orlando Lopes
Paul Rabinowitz
Bernhard Ruf
Carlos Tomei

On Djairo de Figueiredo. A Mathematician

J. Palis

Djairo is one of the most prominent Brazilian mathematicians.

From the beginning he was a very bright student at the engineering school of the University of Brazil, later renamed Federal University of Rio de Janeiro. He turned out to be a natural choice to be awarded one of the not so many fellowships, then offered by our National Research Council - CNPq, for Brazilians to obtain a doctoral degree abroad. While advancing in his university courses, he participated at this very engineering school in a parallel mathematical seminar, conducted by Mauricio Peixoto. Mauricio, who was the *catedrático* of Rational Mechanics and about to become a world figure, suggested to Djairo to get a PhD in probability and statistics.

Actually, Elon Lima, also one of our world figures, tells me that he had the occasion to detect Djairo's talent some years before at a boarding house in Fortaleza, where they met by pure chance. Djairo was 15 years old and Elon, then a high school teacher and an university freshman, just a few years older. Full of enthusiasm for mathematics, one day Elon initiated a private course to explain the construction of the real numbers to the young fellow and one of his colleagues. That Djairo was able to fully understand such subtle abstract piece of mathematics, tells us of both his talent as well as that of Elon for learning and teaching. They both went to Rio, one to initiate and the other to complete their university degrees. Amazingly, for a while again they lived under the same roof, in *Casa do Estudante do Brasil* (curiously, two of my brothers were also staying there at the time), and continued to talk about mathematics. First, Elon departed to the University of Chicago and Djairo, a couple of years later, to the Courant Institute at the University of New York, where they obtained their PhDs.

At Courant, it happened that Djairo did not get a degree neither in probability nor in statistics, as it's so common among us not to strictly follow a well meant advice, in this case by Peixoto to him. Djairo was instead enchanted by the charm of partial differential equations, under the guidance of Louis Nirenberg. Louis and him became friends forever. He was to become an authority on elliptic partial differential equations, linear and nonlinear, individual ones or systems of them. His thesis appeared in *Communications on Pure and Applied Mathematics*, a very distinguished journal.

He then returned briefly to Rio de Janeiro staying at the Instituto de Matemática Pura e Aplicada – IMPA. Soon, he went to Brasília to start a “dream” University, together with his colleague Geraldo Ávila, as advised by Elon Lima to the founder of it, Darcy Ribeiro. In 1965 he returned to the United States. This time, he went to the University of Wisconsin and right after to the University of Illinois for perhaps a longer stay than he might have thought at first: unfortunately, undue external and undemocratic pressure led to a serious crisis at his home institution. In this period he developed collaborations with Felix Browder on the theory of monotone operators and with L.A. Karlovitz on the geometry of Banach spaces and applications, a bit different from his main topic of research as mentioned above.

After spending another year at IMPA, Djairo went back to the University of Brasília in the early 70’s, having as a main goal to rebuilt as possible the initial exceptionally good scientific atmosphere. He did so together with Geraldo Ávila and, subsequently, other capable colleagues. Their efforts bore good fruits. He retired from Brasília in the late 80’s and faced a new challenge: to upgrade mathematics in the University of Campinas by his constant and stimulating activity, high scientific competence and dedicated work. He has been, again from the beginning, a major figure at this new environment. And he continues to be so today, when we are celebrating his 70’s Anniversary.

To commemorate this especial occasion for Brazilian mathematics, a high level Conference was programmed. More than one hundred of his friend mathematicians took part on it, including forty-three foreigners from thirteen countries. Also, a number of his former PhD students and several grand-students.

In his career, Djairo produced about eighty research articles published in very good journals. His range of co-authors is rather broad, among them Gossez, Gupta, Pierre-Louis Lions, Nussbaum, Mitidieri, Ruf, Jianfu, Costa, Felmer, Miyagaki, and, as mentioned above, Felix Browder. He is a wonderful, very inspiring lecturer at all levels, from introductory to frontier mathematics. Such a remarkable feature spreads over the several books he has written. Among them are to be mentioned *Análise de Fourier e EDP – Projeto Euclides*, much appreciated by a wide range of students, including engineering ones, and *Teoria do Potencial – Notas de Matemática*, both from IMPA.

On the way to all such achievements, he was elected Member of the Brazilian Academy of Sciences and The Academy of Sciences for the Developing World - TWAS. He is a Doctor Honoris Causa of the Federal University of Paraíba and Professor Emeritus of the University of Campinas. He has also been distinguished with the Brazilian Government Commend of Scientific Merit – Grand Croix.

Above all, Djairo is a sweet and very gregarious person. We tend to remember him always smiling

Rio de Janeiro, 3 de Agosto de 2005.

Remarks on a Class of Neumann Problems Involving Critical Exponents

Emerson A. M. Abreu¹, Paulo Cesar Carrião² and Olimpio Hiroshi Miyagaki³

Dedicated to Professor D.G.Figueiredo on the occasion of his 70th birthday

Abstract. This paper deals with a class of elliptic problems with double critical exponents involving convex and concave-convex nonlinearities. Existence results are obtained by exploring some properties of the best Sobolev trace constant together with an approach developed by Brezis and Nirenberg.

Mathematics Subject Classification (2000). 35J20, 35J25, 35J33, 35J38.

Keywords. Sobolev trace exponents, elliptic equations, critical exponents and boundary value problems.

1. Introduction

This paper deals with a class of elliptic problems with double critical exponents involving convex and concave-convex nonlinearities of the type

$$-\Delta u = u^{2^*-1} + f(x, u) \quad \text{in } \Omega, \quad (1)$$

$$\frac{\partial u}{\partial \nu} = u^{2_*-1} + g(x, u) \quad \text{on } \partial\Omega, \quad (2)$$

$$u > 0 \quad \text{in } \Omega, \quad (3)$$

where $\Omega \subset \mathbb{R}^N$, ($N \geq 3$), is a bounded smooth domain, $\frac{\partial u}{\partial \nu}$ is the outer unit normal derivative, f and g have subcritical growth at infinity, $2^* = \frac{2N}{N-2}$ and $2_* = \frac{2(N-1)}{N-2}$ are the limiting Sobolev exponents for the embedding $H_0^1(\Omega) \subset L^{2^*}(\Omega)$ and $H^1(\mathbb{R}_+^N) \hookrightarrow L^{2_*}(\partial\mathbb{R}_+^N)$, respectively, where $\mathbb{R}_+^N = \{(x, t) : x \in \mathbb{R}^{N-1}, t > 0\}$.

¹ Supported in part by CNPq-Brazil and FUNDEP/Brazil

² Supported in part by CNPq-Brazil

³ Supported in part by CNPq-Brazil and AGIMB-Millennium Institute-MCT/Brazil

In a famous paper [6], Brezis and Nirenberg proved some existence results for (1) and (3) with Dirichlet boundary condition and f satisfying the following conditions:

$$f(x, 0) = 0 \quad \text{and} \quad \lim_{s \rightarrow +\infty} \frac{f(x, s)}{s^{2^*-1}} = 0, \quad (f0)$$

$$\begin{aligned} &\text{there exists some function } h(s) \text{ such that} \\ &f(x, s) \geq h(s) \geq 0, \text{ for a.e. } x \in \omega \quad \forall s \geq 0, \end{aligned} \quad (f1)$$

where ω is some nonempty open set in Ω and the primitive $H(s) = \int_0^s h(t)dt$ satisfies

$$\lim_{\epsilon \rightarrow 0} \int_0^{\epsilon^{-1}} \epsilon^2 H\left[\left(\frac{\epsilon^{-1}}{1+s^2}\right)^{\frac{N-2}{2}}\right] s^{N-1} ds = \infty, \quad (f2)$$

$$\begin{aligned} f : \Omega \times [0, \infty) &\longrightarrow \mathbb{R} \text{ is measurable in } x \in \Omega, \text{ continuous in} \\ &s \in [0, \infty), \text{ and } \sup_{x \in \Omega, s \in [0, M]} |f(x, s)| < \infty, \text{ for all } M > 0, \end{aligned} \quad (f3)$$

$$\begin{aligned} &f(x, s) = a(x)s + f_1(x, s) \text{ with } a \in L^\infty(\Omega), \\ \lim_{s \rightarrow 0} \frac{f_1(x, s)}{s} = 0 \quad \text{and} \quad \lim_{s \rightarrow \infty} \frac{f_1(x, s)}{s^{2^*-1}} = 0, \quad &\text{uniformly in } x. \end{aligned} \quad (f4)$$

Actually, in spite of the embedding $H_0^1(\Omega) \subset L^{2^*}(\Omega)$ not being compact any longer, they were able to get some compactness condition, proving that the critical level of the Euler-Lagrange functional associated to (1) with Dirichlet boundary condition lies below the critical number $\frac{1}{N}S^{N/2}$, where

$$S = \inf \left\{ \int_{\Omega} |\nabla u|^2 dx : \int_{\Omega} |u|^{2^*} dx = 1, \quad 0 \neq u \in H_0^1(\Omega) \right\}.$$

Still in the Dirichlet condition case, in [2] Ambrosetti, Brezis and Cerami treated a situation involving concave and convex nonlinearities. Recently, Garcia-Azorero, Peral and Rossi in [12] studied a concave-convex problem involving sub-critical nonlinearities on the boundary.

The problem (1)–(3) with $f = g = 0$ was first studied in [11, Theorem 3.3], which was generalized in [8] (see also [9]). In [18] symmetric properties of solutions were obtained, but, basically in these papers it was proved that every positive solution w_ϵ of the partial differential equation with nonlinear boundary condition

$$\begin{cases} -\Delta u = N(N-2)u^\alpha & \text{in } \mathbb{R}_+^N, \\ \frac{\partial u}{\partial t} = cu^\beta & \text{on } \partial \mathbb{R}_+^N, \end{cases} \quad (E)$$

with $\alpha = 2^* - 1$ and $\beta = 2_* - 1$, verifies

$$w_\epsilon(x, t) = \left(\frac{\epsilon}{\epsilon^2 + |(x, t) - (x_0, t_0)|^2} \right)^{\frac{N-2}{2}}$$

for some $\epsilon > 0$ where $(N-2)t_0\epsilon^{-1} = c$. Equivalently the minimizing problem

$$S_0 = \inf \{ |\nabla u|_{2, \mathbb{R}_+^N}^2 : |u|_{2_*, \mathbb{R}_+^N}^2 + |u|_{2^*, \mathbb{R}_+^N}^2 = 1 \}$$

is attained by the above function $w_\epsilon(x, t)$, where $|u|_{a, \Omega}$ denotes the usual $L^a(\Omega)$ -norm.

We would like to mention the papers [4, 7, 14, 19] for more information about the Sobolev trace inequality, as well as related results involving the Yamabe problem. Still in \mathbb{R}_+^N , in [9] a nonexistence result for (E) was proved for the case that one of the inequalities $\alpha \leq 2^* - 1$, $\beta \leq 2_* - 1$, is strict (see also [13]).

When the domain Ω is unbounded, by applying the concentration compactness principle, Lions in [15] studied some minimization problems related to (1)–(3) with linear perturbations. Recently in [5], (see also [10]) a quasilinear problem was studied involving a subcritical nonlinearity in Ω and a perturbation of a critical situation on $\partial\Omega$, while in [16], the critical case is treated and some existence results for (1)–(3) with $f = 0$, $g(s) = \delta s$, $\delta > 0$ and $N \geq 4$ were proved (see also in [17] when Ω is a ball).

On the other hand, making $f(x, s) = \lambda s$, $g(x, s) = \mu s$, with $\lambda, \mu \in \mathbb{R}$, in (1)–(3), and arguing as in the proof of Pohozaev’s identity, more exactly, multiplying the first equation (1) by $x \cdot \nabla u$, we obtain

$$\begin{aligned} 0 &= \operatorname{div}(\nabla u(x \cdot \nabla u) - x \frac{|\nabla u|^2}{2} + x(\frac{\lambda}{2}u^2 + \frac{1}{2^*}u^{2^*})) \\ &\quad + \frac{N-2}{2}|\nabla u|^2 - N(\frac{\lambda}{2}u^2 + \frac{1}{2^*}u^{2^*}). \end{aligned}$$

Integrating this equality over Ω , we have

$$\begin{aligned} 0 &= \int_{\partial\Omega} \langle x, \nu \rangle (\frac{|\nabla u|^2}{2} + (\frac{\lambda}{2}u^2 + \frac{1}{2^*}u^{2^*})) \\ &\quad + \frac{N-2}{2}(\int_{\partial\Omega} \mu u^2 + u^{2^*}) - \lambda \int_{\Omega} u^2. \end{aligned}$$

From this identity we can conclude that, for instance, if Ω is star-shaped with respect to the origin in \mathbb{R}^N , $\lambda = 0$ and $\mu \geq 0$, then any solution of (1)–(3) vanishes identically.

We would like to point out that hereafter $\int_{\Omega} f$ and $\int_{\partial\Omega} g$ mean $\int_{\Omega} f(x)dx$ and $\int_{\partial\Omega} g(y)d\sigma$, respectively.

Motivated by the above papers and remarks, in order to state our first result, we make some assumptions on f and g , namely,

$$\begin{aligned} g(y, s) &= b(y)s + g_1(y, s), \quad y \in \partial\Omega, \quad s \in \mathbb{R} \quad \text{and} \quad b \in L^\infty(\partial\Omega) \\ g(y, s) &\geq 0, \quad \forall y \in \partial w \cap \partial\Omega \neq \emptyset, \end{aligned} \tag{g1}$$

$$\lim_{s \rightarrow 0} \frac{g_1(y, s)}{s} = 0 \quad \text{and} \quad \lim_{s \rightarrow \infty} \frac{g_1(y, s)}{s^{2^*-1}} = 0, \quad \text{uniformly in } y, \tag{g2}$$

$$0 < \Theta_1 \leq \inf\{||u||^2 - 2 \int_{\partial\Omega} b u^2 : ||u|| = 1\} \quad \text{for some } \Theta_1 \in \mathbb{R}, \tag{g3}$$

there exists $\varrho \geq 1$ with $a + \varrho > 0$ on a subset of Ω of positive Lebesgue measure in \mathbb{R}^N such that

$$0 < \Theta_2 \leq \inf\{ \|u\|^2 - 2 \int_{\Omega} (\varrho + a)u^2 : \|u\| = 1 \}, \quad \text{for some } \Theta_2 \in \mathbb{R}, \quad (f5)$$

where $\|u\|^2 = \|\nabla u\|_{2,\Omega}^2 + \|u\|_{2,\Omega}^2$ denotes the usual norm in $H^1(\Omega)$.

Our first result is the following.

Theorem 1.1 (Convex case). *Assume that (g_1) – (g_3) and (f_0) – (f_5) hold. Then problem (1)–(3) possesses at least one positive solution.*

Remark 1.1. The above result still holds when $f = 0$ and g verify the condition

there exists some function $p(s)$ such that

$$g(y, s) \geq p(s) \geq 0, \quad \text{for a.e. } y \in \partial\Omega \cup \partial w, \quad \forall s \geq 0,$$

and the primitive $P(s) = \int_0^s p(t)dt$ satisfies

$$\lim_{\epsilon \rightarrow 0} \int_0^{\epsilon^{-1}} \epsilon P\left[\left(\frac{\epsilon^{-1}}{1+s^2}\right)^{\frac{N-2}{2}}\right] s^{N-2} ds = \infty.$$

Because, since $(N-2)t_o = c\epsilon$, we have

$$\begin{aligned} & \frac{1}{\epsilon^{N-2}} \int_{B_R(x_o, t_o) \cap \{t=0\}} P\left[\left(\frac{A\epsilon}{\epsilon^2 + |x - x_o|^2 + |t - t_o|^2}\right)^{N-2/2}\right] \\ &= \frac{1}{\epsilon^{N-2}} \int_{B_R(x_o, t_o) \cap \{t=0\}} P\left[\left(\frac{A\epsilon}{d\epsilon^2 + |x - x_o|^2}\right)^{N-2/2}\right] \\ &= \epsilon B \int_0^{R/d\epsilon} P\left[\left(\frac{A\epsilon^{-1}}{1+r^2}\right)^{N-2/2}\right] r^{N-2} dr, \end{aligned}$$

where $d = (c/(N-2))^2 + 1$ and $A, B > 0$.

Remark 1.2. In [16, 17] it was proved that the functional levels $c = c(\delta)$ where the Palais–Smale sequence can converge are close to the critical number $c(0) = \frac{1}{N}S^{N/2}$, when δ goes to $+\infty$. In our work, we are going to use the number S_0 , which verifies the inequality $S_0 < S$. So, for δ large enough, we obtain

$$\bar{S} \equiv \left(\frac{1}{2} - \frac{1}{2_*}\right) \max\{S_0^{\frac{2^*}{2^*-2}}, S_0^{\frac{2_*}{2^*-2}}\} \leq c(\delta) < \frac{1}{N}S^{N/2}.$$

Assuming some condition on F and G , as in [6, page 462], the functional level of our solution u [see Remark 3.1 below] is less than the number \bar{S} .

Since with the techniques used here the case $f = 0$, $g(s) = \delta s$ can be treated, combining this fact with our result we have a multiplicity result, when $N \geq 4$.

Finally, we would like to point out that the hypothesis (g_3) and the structure of the problem studied in this paper includes the main hypothesis in [16, 17], so we also obtain at least one solution if $N = 3$.

Next, we treat the concave-convex case. For this we define

$$f(x, s) = a(x)s + \lambda f_1(x, s), \quad g(y, s) = b(y)s + \mu g_1(y, s), \quad \lambda, \mu > 0,$$

with $a \in L^\infty(\Omega)$, $b \in L^\infty(\partial\Omega)$, and we will assume that

$$\lim_{s \rightarrow 0} \frac{f_1(x, s)}{s^q} = 0 \quad \text{and} \quad \lim_{s \rightarrow \infty} \frac{f_1(x, s)}{s^{2^*-1}} = 0, \quad \text{uniformly in } x, \quad (f6)$$

$$\lim_{s \rightarrow 0} \frac{g_1(y, s)}{s^\tau} = 0 \quad \text{and} \quad \lim_{s \rightarrow \infty} \frac{g_1(y, s)}{s^{2^*-1}} = 0, \quad \text{uniformly in } y, \quad (g4)$$

where $1 < q, \tau < 2$.

We state our result in this case:

Theorem 1.2 (Concave-convex case). *Assume that (g_1) , (g_3) , (g_4) , (f_0) , (f_1) , (f_2) , (f_3) , (f_5) and (f_6) hold. Then problem (1)–(3) has at least one positive solution with $\lambda, \mu > 0$, sufficiently small.*

Remark 1.3. In our forthcoming paper [1] we obtained some multiplicity results in the concave-convex case.

The paper is divided up as follows. In Section 2 some preliminary results will be stated. In Section 3 we shall deal with the convex case, and the concave-convex case will be treated in the last section.

2. Preliminary results

In this section, we are going to state some preliminary remarks. Since we are concerned with the existence of a positive solution, we can assume

$$f_1(x, s) = 0, \quad x \in \Omega, \quad s \leq 0 \quad \text{and} \quad g_1(y, s) = 0, \quad y \in \partial\Omega, \quad s \leq 0.$$

Define the Euler–Lagrange functional $\Phi : H^1(\Omega) \rightarrow \mathbb{R}$, associated to problem (P),

$$\Phi(u) = \frac{1}{2} \int_{\Omega} |\nabla u|^2 - \int_{\Omega} \left(\frac{1}{2} au^2 + F_1(x, u) + \frac{|u|^{2^*}}{2^*} \right) - \int_{\partial\Omega} \left(\frac{1}{2} bu^2 + G_1(y, u) + \frac{|u|^{2^*}}{2^*} \right)$$

where $F_1(x, u) = \int_0^u f_1(x, t)dt$ and $G_1(x, u) = \int_0^u g_1(x, t)dt$. It is standard to see that $\Phi \in C^1$ and

$$\begin{aligned} \Phi'(u)v &= \int_{\Omega} \nabla u \nabla v - \int_{\Omega} (auv + f_1(x, u)v + |u|^{2^*-2}uv) \\ &\quad - \int_{\partial\Omega} (buv + g_1(y, u)v + |u|^{2^*-2}uv), \quad u, v \in H^1(\Omega). \end{aligned}$$

The proofs of our results are made by employing the variational techniques, and the best constant S_0 introduced by Escobar will play an important role in our arguments.

3. Convex case

In this section, we shall adapt some arguments made in the proof of Theorem 2.1 in [6]. From (f4) we can fix $\varrho \geq 1$ large enough so that

$$-f(x, u) \leq \varrho u + u^{2^*-1} \quad \text{a.e. } x \in \Omega, \forall u \geq 0.$$

Define the functional on $H^1(\Omega)$ by

$$\begin{aligned} \Phi(u) &= \int_{\Omega} \left(\frac{1}{2} |\nabla u|^2 + \frac{1}{2} \varrho u^2 - \frac{1}{2} \varrho u_+^2 - \frac{1}{2^*} u_+^{2^*} - F(x, u_+) \right) \\ &\quad - \int_{\partial\Omega} \left(G(y, u_+) + \frac{1}{2_*} u_+^{2_*} \right), \quad u_+ = \max\{u, 0\}. \end{aligned}$$

It is standard to prove that $\Phi \in C^1$.

Now Φ verifies the mountain pass geometry, namely

Lemma 3.1. Φ verifies

i) There exist positive constants ρ and β such that

$$\Phi(u) \geq \beta, \quad \|u\| = \rho.$$

ii) There exist a positive constant $R > \rho$, and $u_0 \in H^1(\Omega)$ such that

$$\Phi(u_0) < 0, \quad \|u_0\| > R.$$

Proof. From (f4), for any $\epsilon > 0$, there exists a constant $C_\epsilon > 0$ such that

$$F(x, u) \leq \frac{1}{2} a u^2 + \frac{C_\epsilon}{2^*} u^{2^*} + \frac{1}{2} \epsilon u^2 \quad \text{for a.e. } x \in \Omega, \forall u \geq 0.$$

Similarly from (g1) and (g2), there exists some constant $D_\epsilon > 0$, such that

$$G(y, u) \leq \frac{1}{2} b u^2 + \frac{D_\epsilon}{2_*} u^{2_*} + \frac{1}{2} \epsilon u^2 \quad \text{for a.e. } y \in \partial\Omega, \forall u \geq 0.$$

Therefore

$$\begin{aligned} \Phi(u) &\geq \frac{1}{4} \|u\|^2 + \frac{1}{4} \|u\|^2 + \int_{\Omega} \left(-\frac{1}{2} (\varrho + a) u^2 - \frac{1}{2^*} u_+^{2^*} - \frac{C_\epsilon}{2^*} u_+^{2^*} - \frac{1}{2} \epsilon u_+^2 \right) \\ &\quad + \int_{\partial\Omega} \left(-\frac{1}{2} b u_+^2 - \frac{1}{2_*} u_+^{2_*} - \frac{D_\epsilon}{2_*} u_+^{2_*} - \frac{1}{2} \epsilon u_+^2 \right). \end{aligned}$$

From (g3) and (f5) follows that

$$\frac{1}{4} \|u\|^2 - \frac{1}{2} \int_{\Omega} (\varrho + a) u^2 \geq \frac{\Theta_2}{4} \|u\|^2$$

and

$$\frac{1}{4} \|u\|^2 - \frac{1}{2} \int_{\partial\Omega} b u^2 \geq \frac{\Theta_1}{4} \|u\|^2.$$

Thus

$$\Phi(u) \geq C_1 \|u\|^2 - C_2 \|u\|^{2^*} - C_3 \|u\|^{2_*}, \quad C_1, C_2, C_3 > 0.$$

This proves (i).

The proof of (ii) follows observing that for fixed $0 \neq u \in H^1(\Omega)$,

$$\Phi(tu) \rightarrow -\infty \text{ as } t \rightarrow \infty.$$

This proves Lemma 3.1. □

From Lemma 3.1, applying the mountain pass theorem due to Ambrosetti and Rabinowitz [3], there is a $(PS)_c$ sequence $\{u_n\} \subset H^1(\Omega)$ such that

$$\Phi(u_n) \rightarrow c, \Phi'(u_n) \rightarrow 0, \text{ in } H^{-1}(\Omega) \text{ as } n \rightarrow \infty,$$

where

$$c = \inf_{h \in \Gamma} \sup_{t \in [0,1]} \Phi(h(t)) > 0,$$

with

$$\Gamma = \{h \in C([0, 1], H^1(\Omega)) : h(0) = 0 \text{ and } h(1) = u_0\}.$$

The following estimate is the crucial step of our proof.

Lemma 3.2.

$$c < \left(\frac{1}{2} - \frac{1}{2_*}\right) \max\{S_0^{\frac{2^*}{2^*-2}}, S_0^{\frac{2_*}{2^*-2}}\} \equiv \bar{S}.$$

First we are going to complete the proof of Theorem 1.1, postponing the proof of this result.

Proof of Theorem 1.1. First of all we shall prove that there exists a positive constant $C > 0$ such that

$$\|u_n\| \leq C, \forall n \in \mathbb{N}.$$

Indeed, since

$$\Phi(u_n) = c + o(1), \tag{4}$$

$$\Phi'(u_n)u_n = \langle \xi_n, u_n \rangle \text{ with } \xi_n \rightarrow 0 \text{ in } H^{-1}(\Omega). \tag{5}$$

Taking (4)–(5) we infer that

$$\begin{aligned} \frac{1}{N} \int_{\Omega} (u_{n+})^{2^*} + \frac{1}{2(N-1)} \int_{\partial\Omega} (u_{n+})^{2^*} &\leq \int_{\Omega} (-F(x, u_{n+}) + \frac{1}{2}f(x, u_{n+})u_{n+}) \\ &\quad + \int_{\partial\Omega} (-G(y, u_{n+}) + \frac{1}{2}g(y, u_{n+})u_{n+}) \\ &\quad + c + \frac{1}{2} \|\xi_n\| \|u_n\|. \end{aligned} \tag{6}$$

From (f4) and (g2), for all $\epsilon > 0$, there exist $A_\epsilon, B_\epsilon > 0$ such that

$$\frac{1}{2}f(x, u_{n+})u_{n+} - F(x, u_{n+}) \leq C\epsilon u_+^{2^*} + A_\epsilon u^2, \forall x \in \Omega,$$

$$\frac{1}{2}g(y, u_{n+})u_{n+} - G(y, u_{n+}) \leq C\epsilon u_+^{2_*} + B_\epsilon u^2, \forall y \in \partial\Omega.$$

For ϵ sufficiently small, from (6) we obtain

$$\int_{\Omega} (u_{n+})^{2^*} + \int_{\partial\Omega} (u_{n+})^{2_*} \leq c + C_1 \|u_n\|, \forall n \in \mathbb{N}, \quad C_1 > 0. \tag{7}$$

Combining (7) with (4) we reach that $\|u_n\|$ is bounded.

Now, passing to the subsequence if necessary, we can assume $u_n \rightharpoonup u$ weakly in $H^1(\Omega)$.

Passing to the limit in $\Phi'(u_n)v = o(1)$, $v \in H^1(\Omega)$, as $n \rightarrow \infty$, we have

$$\Phi'(u)v = 0.$$

By the maximum principle it follows that $u \geq 0$ on Ω and u is a positive solution, provided that

Claim $u \neq 0$.

Suppose that $u = 0$. Then since Ω is bounded,

$$\int_{\Omega} f(x, u_{n+})u_{n+} \rightarrow 0 \quad \text{and} \quad \int_{\partial\Omega} g(y, u_{n+})u_{n+} \rightarrow 0, \quad \text{as } n \rightarrow \infty. \quad (8)$$

Combining (8) with (5), we obtain

$$\int_{\Omega} |\nabla u_n|^2 - \int_{\Omega} (u_{n+})^{2^*} - \int_{\partial\Omega} (u_{n+})^{2^*} = o(1),$$

and we can assume

$$\int_{\Omega} |\nabla u_n|^2 \rightarrow l, \quad \int_{\Omega} (u_{n+})^{2^*} \rightarrow l_1 \quad \text{and} \quad \int_{\partial\Omega} (u_{n+})^{2^*} \rightarrow l_2, \quad \text{as } n \rightarrow \infty,$$

with $l = l_1 + l_2$.

Again, since Ω is bounded, we have

$$\int_{\Omega} F(x, u_{n+}) \rightarrow 0, \quad \int_{\partial\Omega} G(y, u_{n+}) \rightarrow 0, \quad \text{as } n \rightarrow \infty,$$

and thus from (4), we infer that

$$\frac{l}{2} - \frac{l_1}{2^*} - \frac{l_2}{2^*} = c. \quad (9)$$

So, we can assume that $l > 0$ (if not the proof is completed).

By definition of S_0 , we obtain

$$l \geq S_0(l_1^{\frac{2}{2^*}} + l_2^{\frac{2}{2^*}}).$$

Since $l = l_1 + l_2$, we have

$$\begin{aligned} 1 &\geq S_0\left(\left(\frac{l_1}{l}\right)^{\frac{2}{2^*}} \frac{1}{l^{\frac{2^*-2}{2^*}}} + \left(\frac{l_2}{l}\right)^{\frac{2}{2^*}} \frac{1}{l^{\frac{2^*-2}{2^*}}}\right) \\ &\geq \min\left\{\frac{1}{l^{\frac{2^*-2}{2^*}}}, \frac{1}{l^{\frac{2^*-2}{2^*}}}\right\} S_0\left(\left(\frac{l_1}{l}\right)^{\frac{2}{2^*}} + \left(\frac{l_2}{l}\right)^{\frac{2}{2^*}}\right) \\ &\geq \min\left\{\frac{1}{l^{\frac{2^*-2}{2^*}}}, \frac{1}{l^{\frac{2^*-2}{2^*}}}\right\} S_0\left(\frac{l_1 + l_2}{l}\right)^{\frac{2}{2^*}} \\ &\geq \min\left\{\frac{1}{l^{\frac{2^*-2}{2^*}}}, \frac{1}{l^{\frac{2^*-2}{2^*}}}\right\} S_0. \end{aligned}$$

From this inequality, we reach

$$\max\left\{l^{\frac{2^*-2}{2^*}}, l^{\frac{2^*-2}{2^*}}\right\} \geq S_0.$$

That is,

$$l \geq \max\{S_0^{\frac{2^*}{2^*-2}}, S_0^{\frac{2^*}{2^*-2}}\}. \quad (10)$$

From (9), we obtain

$$c \geq \left(\frac{1}{2} - \frac{1}{2^*}\right)l \geq \bar{S}$$

which is a contradiction. This proves that $u \neq 0$. \square

Remark 3.1. The solution u of the problem (1)–(3) obtained above satisfies either

$$\Phi(u) = c, \quad (11)$$

or

$$\Phi(u) \leq c - \bar{S}. \quad (12)$$

Indeed, we use the same technique as in [6]. Therefore, take a sequence u_n as in the proof above such that $u_n \rightharpoonup u$ weakly in $H^1(\Omega)$ and $u_n \rightarrow u$ a.e. in $\bar{\Omega}$. So, defining $v_n = u_n - u$, it is not difficult to see that

$$\Phi(u) + \int_{\Omega} \left(\frac{1}{2}|\nabla v_n|^2 - \frac{1}{2^*}(v_{n+})^{2^*}\right) - \int_{\partial\Omega} \frac{1}{2^*}(v_{n+})^{2^*} = c + o(1), \quad (13)$$

and

$$\int_{\Omega} \left(|\nabla v_n|^2 - (v_{n+})^{2^*}\right) - \int_{\partial\Omega} (v_{n+})^{2^*} = o(1).$$

Then, by passing to a subsequence if necessary we obtain

$$\int_{\Omega} |\nabla v_n|^2 \rightarrow l, \quad \int_{\Omega} (v_{n+})^{2^*} \rightarrow l_1, \quad \text{and} \quad \int_{\partial\Omega} (v_{n+})^{2^*} \rightarrow l_2.$$

Hence $l = l_1 + l_2$.

From (10) and (13) we conclude (11) or (12).

Now, we will prove Lemma 3.2.

Proof of Lemma 3.2. It is sufficient to prove that there exists $v_0 \in H^1(\Omega)$, $v_0 \geq 0$ on $\bar{\Omega}$, $v_0 \neq 0$ on Ω , such that

$$\sup_{t \geq 0} \Phi(tv_0) < \bar{S}.$$

First of all we will state some estimates. Consider the cut-off function $\varphi \in C^\infty(\bar{\Omega})$ such that $0 \leq \varphi \leq 1$, $(x, t) \in \Omega \subset \mathbb{R}^{N-1} \times \mathbb{R}$ and $\varphi(x, t) = 1$ on a neighborhood U of (x_0, t_0) such that $U \subset w \subset \Omega$.

Define

$$u_\epsilon(x, t) = w_\epsilon(x, t)\varphi(x, t)$$

and

$$v_\epsilon(x, t) = \frac{u_\epsilon(x, t)}{(|u_\epsilon|_{2^*, \Omega}^2 + |u_\epsilon|_{2^*, \partial\Omega}^2)^{\frac{1}{2}}}.$$

The following estimates are proved by combining [16, Lemma 5.2] with the argument used in the proof of [6, Lemma 1.1]:

$$|\nabla v_\epsilon|_{2, \Omega}^2 = S_0 + O(\epsilon^{N-2}), \quad (14)$$

$$|u_\epsilon|_{2^*, \Omega}^{2^*} = |u_1|_{2^*, \mathbb{R}_+^N}^{2^*} + O(\epsilon^N), \quad (15)$$

$$|u_\epsilon|_{2^*, \partial\Omega}^{2^*} = |u_1|_{2^*, \mathbb{R}^{N+1}}^{2^*} + O(\epsilon^{N-1}), \quad (16)$$

$$|v_\epsilon|_{2, \Omega}^2 = \begin{cases} o(\epsilon) & \text{for } N \geq 4 \\ O(\epsilon) & \text{for } N = 3. \end{cases} \quad (17)$$

As we mentioned before, it is sufficient to show that

$$\sup_{s \geq 0} \Phi(s\tilde{v}_\epsilon) < \bar{S},$$

where $\tilde{v}_\epsilon(x, t) = \alpha v_\epsilon(x, t)$ with $\alpha > 0$ to be chosen later on.

Notice that

$$|\nabla \tilde{v}_\epsilon|_{2, \Omega}^2 = \alpha^2 |\nabla v_\epsilon|_{2, \Omega}^2 \equiv X_\epsilon^2, \quad (18)$$

$$|\tilde{v}_\epsilon|_{2^*, \Omega}^{2^*} = \alpha^{2^*} |v_\epsilon|_{2^*, \Omega}^{2^*} \equiv A_\epsilon^{2^*}, \quad (19)$$

$$|\tilde{v}_\epsilon|_{2^*, \partial\Omega}^{2^*} = \alpha^{2^*} |v_\epsilon|_{2^*, \partial\Omega}^{2^*} \equiv B_\epsilon^{2^*}. \quad (20)$$

Thus substituting these equalities in to the expression of $\Phi(s\tilde{v}_\epsilon)$ we have

$$\Phi(s\tilde{v}_\epsilon) = \frac{s^2}{2} X_\epsilon^2 - \frac{s^{2^*}}{2^*} A_\epsilon^{2^*} - \frac{s^{2^*}}{2^*} B_\epsilon^{2^*} - \int_\Omega F(x, t, s\tilde{v}_\epsilon) - \int_{\partial\Omega} G(y, t, s\tilde{v}_\epsilon).$$

Since $\Phi(s\tilde{v}_\epsilon) \rightarrow -\infty$ as $s \rightarrow \infty$, there exists $s_\epsilon > 0$ such that

$$\sup_{s \geq 0} \Phi(s\tilde{v}_\epsilon) = \Phi(s_\epsilon \tilde{v}_\epsilon) \quad (21)$$

(If $s_\epsilon = 0$ the proof is finished.). From (21) we obtain

$$s_\epsilon X_\epsilon^2 - s_\epsilon^{2^*-1} A_\epsilon^{2^*} - s_\epsilon^{2^*-1} B_\epsilon^{2^*} = \int_\Omega f(x, t, s_\epsilon \tilde{v}_\epsilon) \tilde{v}_\epsilon + \int_{\partial\Omega} g(y, t, s_\epsilon \tilde{v}_\epsilon) \tilde{v}_\epsilon. \quad (22)$$

By using the hypotheses on f and g it follows that

$$X_\epsilon^2 \geq s_\epsilon^{2^*-2} A_\epsilon^{2^*} + s_\epsilon^{2^*-2} B_\epsilon^{2^*}.$$

So, from (18)–(20) we have

$$\begin{aligned} \min\{s_\epsilon^{2^*-2}, s_\epsilon^{2^*-2}\} &\leq \frac{X_\epsilon^2}{A_\epsilon^{2^*} + B_\epsilon^{2^*}} \\ &= \frac{\alpha^2 |\nabla v_\epsilon|_{2, \Omega}^2}{\alpha^{2^*} |v_\epsilon|_{2^*, \Omega}^{2^*} + \alpha^{2^*} |v_\epsilon|_{2^*, \partial\Omega}^{2^*}} \\ &\leq \frac{\alpha^2}{\min\{\alpha^{2^*}, \alpha^{2^*}\}} \left(\frac{|\nabla v_\epsilon|_{2, \Omega}^2}{|v_\epsilon|_{2^*, \Omega}^{2^*} + |v_\epsilon|_{2^*, \partial\Omega}^{2^*}} \right). \end{aligned} \quad (23)$$

Therefore from (14)–(16) and (23) we have

$$\lim_{\epsilon \rightarrow 0} \frac{X_\epsilon^2}{A_\epsilon^{2^*} + B_\epsilon^{2^*}} \leq \frac{1}{\min\{\alpha^{2^*-2}, \alpha^{2^*-2}\}} \left(\frac{S_0}{|u_1|_{2^*, \mathbb{R}_+^N}^{2^*} + |u_1|_{2^*, \mathbb{R}^{N-1}}^{2^*}} \right).$$

Now choosing $\alpha > 0$ such that

$$\frac{1}{\min\{\alpha^{2^*-2}, \alpha^{2^*-2}\}} \left(\frac{1}{|u_1|_{2^*, \mathbb{R}^N}^{2^*} + |u_1|_{2^*, \mathbb{R}^{N-1}}^{2^*}} \right) \leq 1,$$

from (23) results

$$\min\{s_\epsilon^{2^*-2}, s_\epsilon^{2^*-2}\} \leq S_0,$$

that is

$$s_\epsilon \leq \max\{S_0^{(2^*-2)^{-1}}, S_0^{(2^*-2)^{-1}}\}. \quad (24)$$

Also

$$X_\epsilon^2 \leq S_0 + O(\epsilon^{N-2}). \quad (25)$$

Since the critical level $c > 0$, we can assume that $s_\epsilon \geq c_0 > 0$, $\forall \epsilon > 0$.

From (22), we obtain

$$s_\epsilon^{2^*} A_\epsilon^{2^*} + s_\epsilon^{2^*} B_\epsilon^{2^*} \geq s_\epsilon^2 X_\epsilon^2 + O(\epsilon), \quad (26)$$

where in the above inequality we used the following facts

$$\int_\Omega \frac{f(x, t, s_\epsilon \tilde{v}_\epsilon) \tilde{v}_\epsilon}{s_\epsilon} \rightarrow 0 \quad \text{and} \quad \int_{\partial\Omega} \frac{g(x, t, s_\epsilon \tilde{v}_\epsilon) \tilde{v}_\epsilon}{s_\epsilon} \rightarrow 0, \quad \text{as } n \rightarrow \infty.$$

Now inserting (26) into the expression of $\Phi(s_\epsilon \tilde{v}_\epsilon)$, from (17) we infer that

$$\begin{aligned} \Phi(s_\epsilon \tilde{v}_\epsilon) &\leq \frac{s_\epsilon^2}{2} X_\epsilon^2 - \min\left\{\frac{1}{2^*}, \frac{1}{2^*}\right\} s_\epsilon^2 X_\epsilon^2 \\ &\quad - \int_\Omega F(x, t, s_\epsilon \tilde{v}_\epsilon) - \int_{\partial\Omega} G(y, t, s_\epsilon \tilde{v}_\epsilon) + O(\epsilon) \\ &\leq \left(\frac{1}{2} - \frac{1}{2^*}\right) s_\epsilon^2 X_\epsilon^2 - \int_\Omega F(x, t, s_\epsilon \tilde{v}_\epsilon) + O(\epsilon) \\ &= \left(\frac{1}{2} - \frac{1}{2^*}\right) s_\epsilon^2 X_\epsilon^2 + h(x, t, s_\epsilon \tilde{v}_\epsilon) + O(\epsilon), \end{aligned}$$

where $h(x, t, s_\epsilon \tilde{v}_\epsilon) = -\int_\Omega F(x, t, s_\epsilon \tilde{v}_\epsilon)$ and $N \geq 3$.

Arguing as in [6] together with (f2) we can assume

$$\frac{h(x, t, s_\epsilon \tilde{v}_\epsilon)}{\epsilon^{N-2}} \rightarrow -\infty, \quad \text{as } \epsilon \rightarrow \infty. \quad (27)$$

But from (24)

$$s_\epsilon^2 \leq \max\{S_0^{2(2^*-2)^{-1}}, S_0^{2(2^*-2)^{-1}}\},$$

and since (25) holds, we have

$$s_\epsilon^2 X_\epsilon^2 \leq \max\{S_0^{2^*(2^*-2)^{-1}}, S_0^{2^*(2^*-2)^{-1}}\} + O(\epsilon^{N-2}), \quad \text{for } N \geq 3. \quad (28)$$

Therefore, from (27) and (28) we conclude that

$$\Phi(s_\epsilon \tilde{v}_\epsilon) < \bar{S}.$$

This proves Lemma 3.2. □

4. Concave-convex case

First of all, notice that by using the embeddings $H^1(\Omega) \hookrightarrow L^t(\Omega)$ with $t = q, 2^*$, and $H^1(\Omega) \hookrightarrow L^r(\partial\Omega)$ with $r = \tau, 2_*$, we have

$$\begin{aligned} \Phi(u) &\geq \frac{1}{4}(\|u\|^2 - 2 \int_{\Omega} (\varrho + a)u^2) + \frac{1}{4}(\|u\|^2 - 2 \int_{\partial\Omega} bu^2) \\ &\quad - \int_{\Omega} \left(\frac{\lambda}{q} |u|^q + \frac{1}{2^*} |u|^{2^*} \right) - \int_{\partial\Omega} \left(\frac{\mu}{\tau} |u|^\tau + \frac{1}{2_*} |u|^{2_*} \right) \\ &\geq C_1 \|u\|^2 - \lambda C_2 \|u\|^q - \mu C_3 \|u\|^\tau - C_4 \|u\|^{2_*} - C_5 \|u\|^{2^*}, \end{aligned}$$

for some positive constants C_i ($i=1, 2, \dots, 5$).

Define

$$h(t) \equiv h_{\lambda\mu}(t) = C_1 t^2 - \lambda C_2 t^q - \mu C_3 t^\tau - C_4 t^{2_*} - C_5 t^{2^*}.$$

Thus

$$\Phi(u) \geq h(\|u\|).$$

Take the cut-off function $\xi : \mathbb{R}_+ \rightarrow [0, 1]$ nonincreasing, smooth, such that

$$\xi(t) = \begin{cases} 1 & \text{if } t \leq R_0 \\ 0 & \text{if } t \geq R_1, \end{cases}$$

where $0 < R_0 = R_0(\lambda, \mu)$ and $0 < R_1 = R_1(\lambda, \mu)$ are chosen such that $h(s) \leq 0$ for $s \in [0, R_0]$ and $s \in [R_1, \infty]$; and $h(s) \geq 0$ for $s \in [R_0, R_1]$.

Now, setting $\varphi(u) = \xi(\|u\|)$, $u \in H^1(\Omega)$, define the truncated functional

$$\Phi_\varphi(u) \geq \frac{1}{2} \|u\|^2 - \int_{\Omega} (F(x, \varphi(u)u) + \frac{u^{2^*}}{2^*} \varphi(u)) - \int_{\partial\Omega} (G(y, \varphi(u)u) + \frac{u^{2_*}}{2_*} \varphi(u)).$$

Then $\Phi_\varphi \in C^1(B(0, R_0), \mathbb{R})$ ($B(0, R_0) \subset H^1(\Omega)$) and

$$\Phi_\varphi(u) \geq h_{\lambda\mu\varphi}(\|u\|),$$

where

$$h_{\lambda\mu\varphi}(t) = C_1 t^2 - \lambda C_2 t^q - \mu C_3 t^\tau - C_4 t^{2_*} \xi(t) - C_5 t^{2^*} \xi(t)$$

and

$$h_{\lambda\mu}(t) = h_{\lambda\mu\varphi}(t) \text{ if } t \leq R_0.$$

Notice that if $\Phi_\varphi(u) \leq 0$, then $\|u\| \leq R_0$ for some $R_0 > 0$, thus $\Phi = \Phi_\varphi$.

The next Lemma gives us the compactness conditions for our proof.

Lemma 4.1. *For $\lambda, \mu > 0$ sufficiently small, Φ_φ satisfies condition $(PS)_c$, namely, every sequence $(u_k) \subset H^1(\Omega)$ satisfying $\Phi_\varphi(u_k) \rightarrow c$ and $\Phi'_\varphi(u_k) \rightarrow 0$ in $H^{-1}(\Omega)$ is relatively compact, provided*

$$c \in (-\bar{S}, 0) \quad \lambda, \mu > 0 \text{ small enough.}$$

Proof. According to the remarks above, we are going to prove the lemma for $\lambda, \mu > 0$ small enough such that

$$\Phi_\varphi(\bar{u}) \geq h_{\lambda\mu\varphi}(\|\bar{u}\|) \geq -\bar{S}. \quad (29)$$

Let $(u_k) \subset H^1(\Omega)$ such that

$$\Phi_\varphi(u_k) = \Phi(u_k) \rightarrow c, \text{ as } k \rightarrow \infty,$$

$$\Phi'_\varphi(u_k) = \Phi'(u_k) \rightarrow 0 \text{ in } H^{-1}(\Omega), \text{ as } k \rightarrow \infty,$$

with $\|u_k\| \leq R_0$. Then, we can assume that

$$\begin{aligned} u_k &\rightharpoonup u, \text{ (weakly) in } L^{2^*}(\Omega) \text{ and } L^{2^*}(\partial\Omega), \\ u_k &\rightarrow u, \text{ (strongly) in } L^q(\Omega) \text{ and } L^\tau(\partial\Omega), \\ u_k &\rightarrow u, \text{ (a.e.) in } \bar{\Omega}. \end{aligned}$$

Thus

$$\begin{aligned} \frac{1}{2} \int_\Omega (|\nabla u_k|^2 + \varrho |u_k|^2) - \int_\Omega \left(\frac{a}{2} |u_k|^2 + F_1(x, u_k) + \frac{1}{2^*} |u_k|^{2^*} \right) - \int_\Omega \varrho u_{k+}^2 \\ - \int_{\partial\Omega} \left(\frac{b}{2} |u_k|^2 + G_1(y, u_k) + \frac{1}{2_*} |u_k|^{2_*} \right) = c + o(1), \end{aligned}$$

and

$$\begin{cases} -\Delta u_k + \varrho u_k - (a u_k + f_1(x, u_k) + |u_k|^{2^*-2} u_k) - \varrho u_{k+} &= \eta_k, \\ \frac{\partial u_k}{\partial \nu} - (b u_k + g_1(y, u_k) + |u_k|^{2_*-2} u_k) &= \nu_k, \end{cases}$$

where $\eta_k, \nu_k \rightarrow 0$, in $H^{-1}(\Omega)$. That is, $\Phi'_\varphi(u)u = 0$.

Letting $v_k = u_k - u$, by the Brezis and Lieb lemma, we have

$$\Phi_\varphi(u) + \int_\Omega |\nabla v_k|^2 - \frac{1}{2^*} |v_k|_{2^*, \Omega}^{2^*} - \frac{1}{2_*} |v_k|_{2_*, \partial\Omega}^{2_*} = c + o(1), \quad (30)$$

and

$$\int_\Omega |\nabla v_k|^2 - |v_k|_{2^*, \Omega}^{2^*} - |v_k|_{2_*, \partial\Omega}^{2_*} = o(1). \quad (31)$$

Making (30) $-\frac{1}{2^*}$ (31) and (30) $-\frac{1}{2_*}$ (31) we reach

$$\frac{1}{N} \int_\Omega |\nabla v_k|^2 = \left(\frac{1}{2_*} - \frac{1}{2^*} \right) |v_k|_{2_*, \partial\Omega}^{2_*} + c + o(1) - I_\varphi(u), \quad (32)$$

$$\frac{1}{2(N-1)} \int_\Omega |\nabla v_k|^2 = \left(\frac{1}{2_*} - \frac{1}{2^*} \right) |v_k|_{2^*, \Omega}^{2^*} + c + o(1) - I_\varphi(u). \quad (33)$$

From (32) and (33), we can assume (passing if necessary to a subsequence) that

$$\int_\Omega |\nabla v_k|^2 \rightarrow l \geq 0, \text{ as } k \rightarrow \infty,$$

$$|v_k|_{2^*, \Omega}^{2^*} \rightarrow l_1 \geq 0, \quad |v_k|_{2_*, \partial\Omega}^{2_*} \rightarrow l_2 \geq 0, \text{ as } k \rightarrow \infty.$$

Moreover, from (31) we have $l = l_1 + l_2$.

From (30) and (10) we have

$$\Phi_\varphi(u) = c - \frac{l}{2} + \frac{l_1}{2^*} + \frac{l_2}{2_*} < c - \frac{l}{2} + \frac{1}{2_*}l \leq c - \bar{S}.$$

On the other hand combining with (29), we conclude that $c > 0$, which is a contradiction. This completes the proof of Lemma 4.1. \square

Proof of Theorem 1.2. For $\lambda, \mu > 0$ sufficiently small, by applying the Ekeland variational principle for the functional Φ_φ , we will find a global minimum $u \in H^1(\Omega)$ for Φ_φ , that is,

$$\Phi_\varphi(u) = \inf_{H^1(\Omega)} \Phi_\varphi = \Phi_\varphi(|u|).$$

So, we can assume $u > 0$ in Ω . \square

References

- [1] E. A. M. Abreu, P. C. Carrião and O. H. Miyagaki, Multiplicity of nontrivial solution for some elliptic problem with double critical exponents, in preparation.
- [2] A. Ambrosetti, H. Brezis and G. Cerami, Combined effects of concave and convex nonlinearities in some elliptic problems, *J. Funct. Anal.* **122** (1994), 519-543.
- [3] A. Ambrosetti and P. H. Rabinowitz, Dual variational methods in critical point theory and applications, *J. Funct. Anal.* **14** (1973), 349-381.
- [4] W. Beckner, Sharp Sobolev inequality on the sphere and the Moser-Trudinger inequality, *Ann. Math.***138**(1993), 213-242.
- [5] J. F. Bonder and J. D. Rossi, Existence results for the p-Laplacian with nonlinear boundary conditions, *J. Math. Anal. Appl.* **263** (2001), 195-223.
- [6] H. Brezis and L. Nirenberg, Positive solutions of nonlinear elliptic equations involving critical Sobolev exponents, *Comm. Pure Appl. Math.* **36** (1983), 437-477.
- [7] P. Cherrier, Meilleures constantes dans des inégalités relatives aux espaces de Sobolev, *Bull. Sci. Math.***108** (1984), 225-262.
- [8] M. Chipot, I. Shafrir and M. Fila, On the solutions to some elliptic equations with nonlinear Neumann boundary conditions, *Adv. Diff. Eqns.* **1** (1996), 91-110.
- [9] M. Chipot, M. Chlebik, M. Fila and I. Shafrir, Existence of positive solutions of a semilinear elliptic equations in \mathbb{R}_+^N with a nonlinear boundary conditions, *J. Math. Anal. Appl.* **223** (1998), 429-471.
- [10] M. del Pino and C. Flores, Asymptotic behavior of best constant and extremal for trace embeddings in expanding domains, *Comm. P. D. E.* **26** (2001), 2189-2210.
- [11] J. F. Escobar, Uniqueness theorems on conformal deformation of metrics, Sobolev inequalities, and an eigenvalue estimate, *Comm. Pure Appl. Math.* **43** (1990), 857-883.
- [12] J. Garcia Azorero, I. Peral and J. D. Rossi, A convex-concave problem with a nonlinear boundary condition, *J. Diff. Eqns.* **198** (2004), 91-128.
- [13] B. Hu, Nonexistence of a positive solutions of the Laplace equations with a nonlinear boundary condition, *Diff. Int. Eqns.* **7** (1994), 301-313.

- [14] Y. Y. Li and M. Zhu, Sharp Sobolev trace inequalities on riemannian manifolds with boundaries, *Comm. Pure Appl. Math.* **50** (1997), 449-487.
- [15] P. L. Lions, The concentration compactness principle in the calculus of variations. The limit case, part 2., *Rev. Mat. Iberoamericana* **1** (1985), 45-121.
- [16] D. Pierotti and S. Terracini, On a Neumann problem with critical exponents and critical nonlinearity on boundary, *Comm. P.D.E.* **20** (1995), 1155-1187.
- [17] D. Pierotti and S. Terracini, On a Neumann problem involving two critical Sobolev exponents: remarks on geometrical and topological aspects, *Calc. Var.* **5** (1997), 271-291.
- [18] S. Terracini, Symmetry properties of positive solutions to some elliptic equations with nonlinear boundary conditions, *Diff. Int. Eqns.* **8** (1995), 1911-1922.
- [19] M. Zhu, Some general forms of Sharp Sobolev inequalities, *J. Funct. Anal.* **156** (1998), 75-120.

Emerson A. M. Abreu and Paulo Cesar Carrião
Departamento de Matemática
Universidade Federal de Minas Gerais
31270-010 Belo Horizonte (MG)
Brazil
e-mail: emerson@mat.ufmg.br
carrion@mat.ufmg.br

Olimpio Hiroshi Miyagaki
Departamento de Matemática
Universidade Federal de Viçosa
36571-000 Viçosa (MG)
Brazil
e-mail: olimpio@ufv.br

Existence of Solutions for a Class of Problems in \mathbb{R}^N Involving the $p(x)$ -Laplacian

Claudianor O. Alves and Marco A.S. Souto¹

Abstract. In this work, we study the existence of solutions for a class of problems involving $p(x)$ -Laplacian operator in \mathbb{R}^N . Using variational techniques we show some results of existence for a class of problems involving critical and subcritical growth.

Keywords. Variational methods, Sobolev embedding, quasilinear operator.

1. Introduction

In this paper, we consider the existence of solutions for the following class of quasilinear problems:

$$\begin{cases} -\Delta_{p(x)}u + u^{p(x)-1} = \lambda u^{q(x)} \text{ in } \mathbb{R}^N, \\ u \geq 0, u \neq 0 \text{ and } u \in W^{1,p(x)}(\mathbb{R}^N), \end{cases} \quad (P_\lambda)$$

where $p, q : \mathbb{R}^N \rightarrow \mathbb{R}$ are measurable functions satisfying some growth conditions, λ is a positive parameter and $\Delta_{p(x)}$ is the $p(x)$ -Laplacian operator given by

$$\Delta_{p(x)}u = \operatorname{div}(|\nabla u(x)|^{p(x)-2} \nabla u(x)).$$

Motivated by the papers of Fan et al. [4, 5, 6, 7] and references therein, we consider this class of operators due to the following facts:

- *This operator appears in some physical problems, for example, in the theory of elasticity in mechanics.*
- *This operator has interesting properties, such as, it is not homogeneous if the function p is not constant. This fact implies some difficulties, as for example, we can not use the Lagrange Multiplier Theorem in a lot of problems involving this operator.*

In this work, our main objective is to study the behavior of the functions $q(x)$ and $p(x)$ at infinity to get positive solutions for the problem (P_λ) in \mathbb{R}^N . We would like to mention that the results contained in this work are preliminary and other situations have been considered by the authors.

This paper is organized in the following way: In Section 1, we recall some results involving the space $W^{1,p(x)}(\mathbb{R}^N)$ which can be found in [4, 5, 6, 7]. In Section 2, we study problem (P_λ) considering a $p(x)$ -subcritical case. In that section we get existence of solutions for two different behaviors of $q(x)$ at infinity. In Section 3, we work with the $p(x)$ -critical growth case. Depending of the behavior of the function $q(x)$ at infinity in relation to the number 2^* , we show the existence of a solution for the problem

$$\begin{cases} -\Delta_{p(x)}u = u^{q(x)} & \text{in } \mathbb{R}^N, \\ u \geq 0, u \neq 0 \text{ and } u \in D^{1,p(x)}(\mathbb{R}^N). \end{cases} \quad (P_*)$$

2. A Short Review on the Spaces $W^{k,p(x)}(\mathbb{R}^N)$

In this section, we remember the definitions and some results involving the spaces $W^{k,p(x)}(\mathbb{R}^N)$, which can be found in the papers [4, 5, 6, 7]. Moreover, in the end of this section we write the relations between the functions $p(x)$ and $q(x)$ explored in all this work.

2.1. Definitions and technical results

Throughout this section, Ω is assumed to be an open domain in \mathbb{R}^N , which may be unbounded, with cone property and $p : \overline{\Omega} \rightarrow \mathbb{R}$ a measurable function satisfying

$$1 < p_- := \operatorname{ess\,inf}_{x \in \overline{\Omega}} p(x) \leq p_+ := \operatorname{ess\,sup}_{x \in \overline{\Omega}} p(x) < \frac{N}{k}$$

where k is a given positive integer verifying $kp < N$.

Set

$$L^{p(x)}(\Omega) := \left\{ u : u : \Omega \rightarrow \mathbb{R} \text{ is measurable function, } \int_{\Omega} |u|^{p(x)} dx < \infty \right\}.$$

We can introduce the norm on $L^{p(x)}(\Omega)$ by

$$|u|_{p(x)} := \inf \left\{ \lambda > 0 : \int_{\Omega} \left| \frac{u}{\lambda} \right|^{p(x)} dx \leq 1 \right\},$$

and $L^{p(x)}$ becomes a Banach space. Moreover, it is easy to prove the following result.

Lemma 2.1 *Let $\{u_n\}$ be a sequence in $L^{p(x)}(\Omega)$. Then,*

$$|u_n - u|_{p(x)} \rightarrow 0 \Leftrightarrow \int_{\Omega} |u_n - u|^{p(x)} dx \rightarrow 0 \text{ as } n \rightarrow \infty.$$

For any positive integer k , set

$$W^{k,p(x)}(\Omega) := \left\{ u \in L^{p(x)}(\Omega) : D^\alpha u \in L^{p(x)}(\Omega), |\alpha| \leq k \right\}.$$

We can define the norm on $W^{k,p(x)}(\Omega)$ by

$$\|u\| = |u|_{p(x)} + \sum_{|\alpha| \leq k} |D^\alpha u|_{p(x)}$$

and $W^{k,p(x)}(\Omega)$ also becomes a Banach space.

Hereafter, let us denote by $D^{1,p(x)}(\mathbb{R}^N)$ the closure of $C_0^\infty(\mathbb{R}^N)$ in relation to the norm

$$\|u\|_* = |\nabla u|_{p(x)}.$$

In what follows, we state some results involving these spaces.

Theorem A. *The spaces $L^{p(x)}(\Omega)$, $W^{k,p(x)}(\Omega)$ and $D^{1,p(x)}(\mathbb{R}^N)$ are both separable and reflexive.*

Theorem B. *If $p : \overline{\Omega} \rightarrow \mathbb{R}$ is a Lipschitz continuous function and $q : \overline{\Omega} \rightarrow \mathbb{R}$ is a measurable function satisfying*

$$p(x) \leq q(x) \leq p^*(x) = \frac{Np(x)}{N - kp(x)}, \quad \text{a.e } x \in \overline{\Omega},$$

then there is a continuous embedding $W^{k,p(x)}(\Omega) \hookrightarrow L^{q(x)}(\Omega)$.

Hereafter, let us denote by $L_+^\infty(\Omega)$ the set

$$L_+^\infty(\Omega) := \left\{ p : p \in L^\infty(\Omega), \inf_{x \in \Omega} p(x) > 1 \right\},$$

and if $f, g \in L_+^\infty(\Omega)$, let us denote by $f(x) \ll g(x)$ the property

$$\inf_{x \in \Omega} (g(x) - f(x)) > 0.$$

Theorem C. *Let Ω be bounded, $p : \overline{\Omega} \rightarrow \mathbb{R}$ be a continuous functions, and q any measurable function defined in Ω satisfying*

$$p(x) \leq q(x), \quad \text{a.e } x \in \overline{\Omega}$$

and

$$q(x) \ll p^*(x).$$

Then, there is a compact embedding $W^{k,p(x)}(\Omega) \hookrightarrow L^{q(x)}(\Omega)$.

2.2. Hypotheses involving the functions $p(x)$ and $q(x)$

In this paper, we will assume that p and q are continuous functions satisfying

$$p^- \leq p(x) \leq p^+ = \|p\|_\infty \text{ a.e. in } \mathbb{R}^N, \quad (H_1)$$

$$q^- \leq q(x) \leq q^+ = \|q\|_\infty \text{ a.e. in } \mathbb{R}^N, \quad (H_2)$$

with $p^-, q^- > 1$, $p^+ < q^- + 1$ and

$$p(x) - 1 \ll q(x) \ll p^*(x) - 1. \quad (H_3)$$

and

$$p(x) \geq m \text{ a.e. in } \mathbb{R}^N, \quad p(x) \equiv m \text{ for all } |x| \geq R, \quad (H_4)$$

Observe that $m = p^-$. The behavior of the function $p(x)$ at infinity implies the following results:

Lemma 2.2 *Condition (H_4) implies that there exists a continuous embedding between $W^{1,p(x)}(\mathbb{R}^N)$ and $W^{1,m}(\mathbb{R}^N)$.*

Proof. In fact, for each $u \in W^{1,p(x)}(\mathbb{R}^N)$, we have

$$|\nabla u|^m(x) \leq (1 + |\nabla u|^{p(x)})\chi_{B_R}(x) + |\nabla u|^m(1 - \chi_{B_R})(x)$$

and

$$|u|^m(x) \leq (1 + |u|^{p(x)})\chi_{B_R}(x) + |u|^m(1 - \chi_{B_R})(x)$$

for all $x \in \mathbb{R}^N$, where $B_R = B_R(0) = \{x \in \mathbb{R}^N : |x| \leq R\}$, and χ_{B_R} is the characteristic function of B_R . The above inequalities together with Lebesgue's theorem imply that the identity application between $W^{1,p(x)}(\mathbb{R}^N)$ and $W^{1,m}(\mathbb{R}^N)$ is continuous. \square

3. The Mountain Pass Geometry

Since $W^{1,p(x)}(\mathbb{R}^N)$ has different properties than those explored for the case when $p(x)$ is a constant function, a careful analysis is necessary in the mountain pass geometry, and in particular, for the Palais–Smale condition.

The functional of Euler–Lagrange related to problem (P_λ) is given by

$$I_\lambda(v) = \int_{\mathbb{R}^N} \left[\frac{|\nabla v|^{p(x)}}{p(x)} + \frac{|v|^{p(x)}}{p(x)} \right] dx - \lambda \int_{\mathbb{R}^N} \frac{v_+^{q(x)+1}}{q(x)+1} dx.$$

Hereafter, let us denote by I_∞ , the Euler–Lagrange functional related to the problem

$$\begin{cases} -\Delta_m u + u^{m-1} = \lambda u^s & \text{in } \mathbb{R}^N, \\ u \geq 0, u \neq 0 \text{ and } u \in W^{1,m}(\mathbb{R}^N), \end{cases} \quad (P_\infty)$$

which is given by

$$I_\infty(v) = \int_{\mathbb{R}^N} \left[\frac{|\nabla v|^m}{m} + \frac{|v|^m}{m} \right] dx - \lambda \int_{\mathbb{R}^N} \frac{v_+^{s+1}}{s+1} dx$$

where $N < m$, $s \in (m-1, m^*-1)$ and $m^* = \frac{Nm}{N-m}$.

Lemma 3.1 I_λ satisfies the Mountain Pass Geometry.

Proof. Using the definition of the $W^{1,p(x)}(\Omega)$ -norm, we have the following inequalities for $\|v\| = r$ and $r > 0$ sufficiently small:

$$\int_{\Omega} \left[\frac{|\nabla v|^{p(x)}}{p(x)} + \frac{|v|^{p(x)}}{p(x)} \right] \geq \frac{1}{p^+} \left[|\nabla v|_{p(x)}^{p^+} + |v|_{p(x)}^{p^+} \right] \geq C \|v\|^{p^+} \quad (3.1)$$

and

$$\int_{\Omega} \frac{|v|^{q(x)+1}}{q(x)+1} dx \leq \frac{1}{q^-+1} |v|_{q(x)+1}^{q^-+1} \leq C \|v\|^{q^-+1}. \quad (3.2)$$

Since $q^- + 1 > p^+$, from (3.1)–(3.2), there exists $\rho > 0$ such that

$$I_\lambda(v) \geq \rho \text{ for } \|v\| = r. \quad (3.3)$$

On the other hand, fixing a nonnegative function $\phi \in C_0^\infty(\Omega)$, we have for $t > 0$ sufficiently large

$$\int_{\Omega} \left[\frac{|\nabla t\phi|^{p(x)}}{p(x)} + \frac{|t\phi|^{p(x)}}{p(x)} \right] \leq \frac{t^{p^+}}{p^-} \left[|\nabla \phi|_{p(x)}^{p^+} + |\phi|_{p(x)}^{p^+} \right] \leq C t^{p^+} \|\phi\|^{p^+} \quad (3.4)$$

and

$$\int_{\Omega} \frac{|t\phi|^{q(x)+1}}{q(x)+1} dx \geq t^{q^-+1} \int_{\Omega} \frac{|\phi|^{q(x)+1}}{q(x)+1} dx \quad (3.5)$$

From (3.4)–(3.5) it follows

$$I_\lambda(t\phi) \rightarrow -\infty \text{ as } t \rightarrow +\infty. \quad (3.6)$$

From (3.3) and (3.6) it follows the Mountain Pass Geometry. \square

From the last lemma, there is a Palais–Smale sequence $\{u_n\}$ in $W^{1,p(x)}(\mathbb{R}^N)$ satisfying

$$I_\lambda(u_n) \rightarrow c_\lambda \text{ and } I'_\lambda(u_n) \rightarrow 0$$

where

$$c_\lambda = \inf_{\gamma \in \Gamma} \max_{0 \leq t \leq 1} I_\lambda(\gamma(t)),$$

and

$$\Gamma = \left\{ \gamma : [0, 1] \rightarrow W^{1,p(x)}(\mathbb{R}^N) : \gamma(0) = 0 \text{ and } I_\lambda(\gamma(1)) \leq 0 \right\}.$$

Lemma 3.2 Let $\{u_n\}$ be a $(PS)_d$ sequence of I_λ . Then, $\{u_n\}$ has a subsequence, still denoted by $\{u_n\}$, such that:

- $\{u_n\}$ is a bounded sequence with weak limit denoted by u
- $u_n \rightarrow u$ in $W_{loc}^{1,p(x)}(\mathbb{R}^N), W_{loc}^{1,m}(\mathbb{R}^N)$
- $u_n(x) \rightarrow u(x)$ a.e. in \mathbb{R}^N
- $u_n \rightarrow u$ in $L_{loc}^m(\mathbb{R}^N), L_{loc}^{s+1}(\mathbb{R}^N), L_{loc}^{p(x)}(\mathbb{R}^N)$ and $L_{loc}^{q(x)+1}(\mathbb{R}^N)$.

Proof. Let $R_1 > 0$ and $\phi \in C_o^\infty(\mathbb{R}^N)$ such that $\phi = 0$ if $|x| \geq 2R_1$, $\phi = 1$ if $|x| \leq R_1$ and $0 \leq \phi \leq 1$. Since

$$C|\nabla u_n - \nabla u|^{p(x)} \leq \langle |\nabla u_n|^{p(x)-2} \nabla u_n - |\nabla u|^{p(x)-2} \nabla u, \nabla u_n - \nabla u \rangle, \quad (3.7)$$

for some constant $C > 0$, integrating (3.7) in B_{R_1} , we have:

$$C \int_{|x| \leq R_1} |\nabla u_n - \nabla u|^{p(x)} dx \leq \int_{|x| \leq R_1} \langle |\nabla u_n|^{p(x)-2} \nabla u_n - |\nabla u|^{p(x)-2} \nabla u, \nabla u_n - \nabla u \rangle dx.$$

Denoting

$$P_n(x) = \langle |\nabla u_n|^{p(x)-2} \nabla u_n - |\nabla u|^{p(x)-2} \nabla u, \nabla u_n - \nabla u \rangle,$$

we have

$$\begin{aligned} \int_{|x| \leq R_1} P_n dx &\leq I'_\lambda(u_n)(\phi u_n) - I'_\lambda(u_n)(\phi u) - \int_{\mathbb{R}^N} |\nabla u_n|^{p(x)-2} u_n \nabla u_n \nabla \phi \\ &\quad + \int_{\mathbb{R}^N} |\nabla u_n|^{p(x)-2} u \nabla u_n \nabla \phi - \int_{\mathbb{R}^N} \phi |u_n|^{p(x)} + \int_{\mathbb{R}^N} \phi |u_n|^{q(x)+1} \\ &\quad + \int_{\mathbb{R}^N} \phi |u_n|^{p(x)-2} u_n u - \int_{\mathbb{R}^N} \phi |u_n|^{q(x)-2} u_n u, \end{aligned}$$

hence

$$\lim_{n \rightarrow \infty} \int_{\mathbb{R}^N} P_n dx = 0$$

which implies that u_n converges to u in $W^{1,p(x)}(|x| \leq R_1)$. Since this convergence holds for all $R_1 > 0$, we can conclude that u_n converges to u in $W_{loc}^{1,p(x)}(\mathbb{R}^N)$. The other limits follow from the convergence in $W_{loc}^{1,p(x)}(\mathbb{R}^N)$. \square

4. Existence of Solutions

In this section, we will show the existence of a positive solution for (P_λ) . We divide this section in subsections considering different situations involving the geometry of the function $q(x)$ at infinity.

4.1. First Case: Equality at Infinity

In this subsection, we show our first result considering the case where the function q is equal to a constant at infinity.

The next proposition establishes an important inequality involving the minimax level c_∞ of I_∞ .

Proposition 4.1 *Let $\{u_n\}$ be a $(PS)_d$ sequence for I_λ converging weakly to 0 in $W^{1,p(x)}(\mathbb{R}^N)$. Assume that the function q satisfies*

$$q(x) \leq s \text{ a.e in } \mathbb{R}^N \text{ and } q(x) \equiv s, \text{ for all } |x| \geq R. \quad (Q_1)$$

Then, $d \geq c_\infty$.

Proof. In fact, first we will show that $I_\infty(u_n) \rightarrow d$ and $I'_\infty(u_n).u_n \rightarrow 0$.

$$\begin{aligned} I'_\lambda(u_n).u_n - I'_\infty(u_n).u_n &= \int_{\{|x| \leq R\}} [|\nabla u_n|^{p(x)} - |\nabla u_n|^m] dx \\ &\quad + \int_{\{|x| \leq R\}} [|u_n|^{p(x)} - |u_n|^m] dx \\ &\quad + \lambda \int_{\{|x| \leq R\}} [|u_n|^{s+1} - |u_n|^{q(x)+1}] dx. \end{aligned} \quad (4.1)$$

From Lemma 3.2, each term in the right-hand side of (4.1) is $o_n(1)$, and it follows $I'_\infty(u_n) \cdot u_n \rightarrow 0$. In the same way

$$\begin{aligned} I_\lambda(u_n) - I_\infty(u_n) &= \int_{\{|x| \leq R\}} \left[\frac{|\nabla u_n|^{p(x)}}{p(x)} - \frac{|\nabla u_n|^m}{m} \right] dx \\ &+ \int_{\{|x| \leq R\}} \left[\frac{|u_n|^{p(x)}}{p(x)} - \frac{|u_n|^m}{m} \right] dx \\ &+ \lambda \int_{\{|x| \leq R\}} \left[\frac{|u_n|^{s+1}}{s+1} - \frac{|u_n|^{q(x)+1}}{q(x)+1} \right] dx, \end{aligned} \quad (4.2)$$

and $I_\infty(u_n) \rightarrow d$.

Now, let t_n be such that $I_\infty(t_n u_n) = \max_{t>0} I_\infty(t u_n)$. It is easy to check that $t_n \rightarrow 1$. Using the definition of c_∞ , we get

$$\begin{aligned} c_\infty &\leq I_\infty(t_n u_n) = I_\infty(u_n) + I_\infty(t_n u_n) - I_\infty(u_n) \\ &\leq d + o_n(1) + \frac{t_n^m - 1}{m} \int_{\mathbb{R}^N} [|\nabla u_n|^m + |u_n|^m] dx \\ &\quad + \lambda \frac{(1 - t_n^{m+1})}{m+1} \int_{\mathbb{R}^N} |u_n|^{m+1} dx. \end{aligned} \quad (4.3)$$

Taking the limit in (4.3) the proof of this proposition is done. \square

Lemma 4.1 *If (Q_1) holds, we have $c_\lambda < c_\infty$.*

Proof. Fix a positive radially symmetric ground state solution ω for the limit problem

$$\begin{cases} -\Delta_m \omega + \omega^{m-1} = \lambda \omega^s & \text{in } \mathbb{R}^N, \\ \omega \in W^{1,p}(\mathbb{R}^N). \end{cases} \quad (P_\infty)$$

Let $x_n = (0, 0, \dots, n)$, $\omega_n = \omega(x - x_n)$ and t_n such that

$$I_\lambda(t_n \omega_n) = \max_{t>0} I_\lambda(t \omega_n).$$

We have

$$\begin{aligned} c_\lambda &\leq I_\lambda(t_n \omega_n) = I_\infty(t_n \omega_n) + I_\lambda(t_n \omega_n) - I_\infty(t_n \omega_n) \\ &\leq c_\infty + \int_{\{|x| \leq R\}} \left[\frac{|t_n \nabla \omega_n|^{p(x)}}{p(x)} - \frac{|t_n \nabla \omega_n|^m}{m} \right] dx \\ &\quad + \int_{\{|x| \leq R\}} \left[\frac{|t_n \omega_n|^{p(x)}}{p(x)} - \frac{|t_n \omega_n|^m}{m} \right] dx \\ &\quad + \lambda \int_{\{|x| \leq R\}} \left[\frac{|t_n \omega_n|^{s+1}}{s+1} - \frac{|t_n \omega_n|^{q(x)+1}}{q(x)+1} \right] dx. \end{aligned} \quad (4.4)$$

Fix an index n large enough such that $|\nabla t_n \omega_n| < 1$ and $|t_n \omega_n| < 1$ in $B_R(0)$. Since the function $f(s) = s^{-1} a^s$ is decreasing in $(0, +\infty)$, if $0 < a < 1$, for that n , the terms

$$\int_{\{|x| \leq R\}} \left[\frac{|t_n \nabla \omega_n|^{p(x)}}{p(x)} - \frac{|t_n \nabla \omega_n|^m}{m} \right] dx, \quad \int_{\{|x| \leq R\}} \left[\frac{|t_n \omega_n|^{p(x)}}{p(x)} - \frac{|t_n \omega_n|^m}{m} \right] dx$$

and

$$\lambda \int_{\{|x| \leq R\}} \left[\frac{|t_n \omega_n|^{s+1}}{s+1} - \frac{|t_n \omega_n|^{q(x)+1}}{q(x)+1} \right] dx$$

are negative, and then (4.4) implies $c_\lambda < c_\infty$. \square

Theorem 4.1 *Assume that (H_1) – (H_4) and (Q_1) hold. Then, problem (P_λ) has a ground state solution for all $\lambda > 0$.*

Proof. For each $\phi \in C_0^\infty(\mathbb{R}^N)$, the $(PS)_{c_\lambda}$ sequence $\{u_n\}$ satisfies

$$\int_{\mathbb{R}^N} \left[|\nabla u_n|^{p(x)-2} \nabla u_n \cdot \nabla \phi + |u_n|^{p(x)-2} u_n \phi \right] dx = \lambda \int_{\mathbb{R}^N} |u_n|^{q(x)-1} u_n \phi dx + o_n(1).$$

From Lemma 3.2, taking the limit above we have

$$\int_{\mathbb{R}^N} \left[|\nabla u|^{p(x)-2} \nabla u \cdot \nabla \phi + |u|^{p(x)-2} u \phi \right] dx = \lambda \int_{\mathbb{R}^N} |u|^{q(x)-1} u \phi dx.$$

Thus u is a solution and, combining Lemma 4.1 and Proposition 4.1, the function u can not be zero. \square

4.2. Second Case: Asymptotically Constant at Infinity (Part I)

Lemma 4.2 *Let $\{u_n\}$ be a $(PS)_c$ sequence for I_λ converging weakly to 0 in $W^{1,p(x)}(\mathbb{R}^N)$. Assume the limit*

$$\lim_{|x| \rightarrow \infty} q(x) = s. \quad (Q_2)$$

Then $c \geq c_\infty$, where c_∞ denotes the minimax level of the Euler–Lagrange functional I_∞ .

Proof. In fact, first we will show that $I_\infty(u_n) \rightarrow c$ and $I'_\infty(u_n) \cdot u_n \rightarrow 0$.

$$\begin{aligned} I'_\lambda(u_n) \cdot u_n - I'_\infty(u_n) \cdot u_n &= \int_{\{|x| \leq R\}} \left[|\nabla u_n|^{p(x)} - |\nabla u_n|^m \right] dx \\ &\quad + \int_{\{|x| \leq R\}} \left[|u_n|^{p(x)} - |u_n|^m \right] dx \\ &\quad + \lambda \int_{\mathbb{R}^N} \left[|u_n|^{s+1} - |u_n|^{q(x)+1} \right] dx. \end{aligned} \quad (4.5)$$

As in the Proposition 4.1, the first two terms in the right side of the equality (4.5) are $o_n(1)$. For the third term, we write

$$\int_{\mathbb{R}^N} \left[|u_n|^{s+1} - |u_n|^{q(x)+1} \right] dx = o_n(1) + \int_{\{|x| \geq R\}} \left[|u_n|^{s+1} - |u_n|^{q(x)+1} \right] dx \quad (4.6)$$

where

$$o_n(1) = \int_{\{|x| \leq R\}} \left[|u_n|^{s+1} - |u_n|^{q(x)+1} \right] dx.$$

Observe that

$$\int_{\{|x| \geq R\}} \left[|u_n|^{s+1} - |u_n|^{q(x)+1} \right] dx \leq C \int_{\{|x| \geq R\}} \left[|u_n|^{p(x)} + |u_n|^{p^*(x)} \right] |q(x) - s| dx$$

and, by using condition (Q_2) ,

$$\int_{\{|x| \geq R\}} \left[|u_n|^{s+1} - |u_n|^{q(x)+1} \right] dx \leq o_R(1) \int_{\{|x| \geq R\}} \left[|u_n|^{p(x)} + |u_n|^{p^*(x)} \right] dx. \quad (4.7)$$

For each $\varepsilon > 0$, choose $R > 0$ such that

$$o_R(1) \int_{\{|x| \geq R\}} \left[|u_n|^{p(x)} + |u_n|^{p^*(x)} \right] dx < \varepsilon/2.$$

Thus, by (4.5), (4.6) and (4.7) we have

$$|I'_\lambda(u_n) \cdot u_n - I'_\infty(u_n) \cdot u_n| < o_n(1) + \frac{1}{2}\varepsilon,$$

and hence $I'_\infty(u_n) \cdot u_n \rightarrow 0$. In the same way, we can show that $I_\infty(u_n) \rightarrow c$.

Now, let t_n be such that $I_\infty(t_n u_n) = \max_{t>0} I_\infty(t u_n)$. As in Proposition 4.1 we have that $t_n \rightarrow 1$. Finally

$$\begin{aligned} c_\infty &\leq I_\infty(t_n u_n) = I_\infty(u_n) + I_\infty(t_n u_n) - I_\infty(u_n) \\ &\leq c + o_n(1) + \frac{t_n^m - 1}{m} \int_{\mathbb{R}^N} [|\nabla u_n|^m + |u_n|^m] dx \\ &\quad + \lambda \frac{(1 - t_n^{s+1})}{s+1} \int_{\mathbb{R}^N} |u_n|^{s+1} dx. \end{aligned}$$

By taking the limit above the proof of this lemma is done. \square

Lemma 4.3 *Assume that (Q_2) holds and $q(x) \leq s$ a.e in \mathbb{R}^N . Then, there is a $\lambda_o > 0$ such that $c_\lambda < c_\infty$, for $\lambda > \lambda_o$.*

Proof. In this case, we can take a $\lambda_o > 0$ large enough such that the solution ω of the problem (P_∞) satisfies $|\omega|_\infty, |\nabla \omega|_\infty < 1$. Moreover, let us fix t_n such that $I_\lambda(t_n \omega_n) = \max_{t>0} I_\lambda(t \omega_n)$. By a direct calculation, we have $t_n \rightarrow 1$ as $n \rightarrow +\infty$, therefore

$$\begin{aligned} c_\lambda &\leq I_\lambda(t_n \omega_n) = I_\infty(t_n \omega_n) + I_\lambda(t_n \omega_n) - I_\infty(t_n \omega_n) \\ &\leq c_\infty + \int_{\{|x| \leq R\}} \left[\frac{|t_n \nabla \omega_n|^{p(x)}}{p(x)} - \frac{|t_n \nabla \omega_n|^m}{m} \right] dx \\ &\quad + \int_{\{|x| \leq R\}} \left[\frac{|t_n \omega_n|^{p(x)}}{p(x)} - \frac{|t_n \omega_n|^m}{m} \right] dx \\ &\quad + \lambda \int_{\mathbb{R}^N} \left[\frac{|t_n \omega_n|^{s+1}}{s+1} - \frac{|t_n \omega_n|^{q(x)+1}}{q(x)+1} \right] dx. \end{aligned} \tag{4.8}$$

Fix an index n large enough such that $|\nabla t_n \omega_n| < 1$ and $|t_n \omega_n| < 1$, in $B_R(0)$. Since the function $f(s) = s^{-1}a^s$ is decreasing in $(0, +\infty)$, if $0 < a < 1$, the terms

$$\int_{\{|x| \leq R\}} \left[\frac{|t_n \nabla \omega_n|^{p(x)}}{p(x)} - \frac{|t_n \nabla \omega_n|^m}{m} \right] dx, \quad \int_{\{|x| \leq R\}} \left[\frac{|t_n \omega_n|^{p(x)}}{p(x)} - \frac{|t_n \omega_n|^m}{m} \right] dx,$$

and

$$\lambda \int_{\mathbb{R}^N} \left[\frac{|t_n \omega_n|^{s+1}}{s+1} - \frac{|t_n \omega_n|^{q(x)+1}}{q(x)+1} \right] dx$$

are negative, and then by (4.8), we have that $c_\lambda < c_\infty$. \square

Theorem 4.2 *Assume that (Q_2) holds and $q(x) \leq s$ a.e in \mathbb{R}^N . Then, for $\lambda > \lambda_o$ problem (P_λ) has a ground state solution.*

Proof. The proof follows from similar arguments to the ones explored in the proof of Theorem 4.1. \square

4.3. Third Case: Asymptotically Constant at Infinity (Part II)

In this subsection, we consider the situation where the function $q(x)$ goes to s with an exponential behavior at infinity.

Lemma 4.4. *Assume that the function q verifies the conditions*

$$|q(x) - s| \leq Ce^{-\gamma|x|}, \text{ for all } x \in \mathbb{R}^N \quad (Q_3)$$

and

$$q(x) \leq s \quad \forall x \in B_R(0). \quad (Q_4)$$

Then, there exists $\gamma^* > 0$ such that $c_\lambda < c_\infty$, for all $\gamma > \gamma^*$.

Proof. As in the Lemmas 4.2 and 4.3, let us fix $t_n \in \mathbb{R}$ verifying $I_\lambda(t_n \omega_n) = \max_{t>0} I_\lambda(t \omega_n)$. By a direct calculation, $t_n \rightarrow 1$ as $n \rightarrow +\infty$, we have

$$c_\lambda \leq I_\lambda(t_n \omega_n) = I_\infty(t_n \omega_n) + I_\lambda(t_n \omega_n) - I_\infty(t_n \omega_n),$$

thus,

$$\begin{aligned} c_\lambda &\leq c_\infty + \int_{\{|x| \leq R\}} \left[\frac{|t_n \nabla \omega_n|^{p(x)}}{p(x)} - \frac{|t_n \nabla \omega_n|^m}{m} \right] dx \\ &\quad + \int_{\{|x| \leq R\}} \left[\frac{|t_n \omega_n|^{p(x)}}{p(x)} - \frac{|t_n \omega_n|^m}{m} \right] dx \\ &\quad + \lambda \int_{\mathbb{R}^N} \left[\frac{|t_n \omega_n|^{s+1}}{s+1} - \frac{|t_n \omega_n|^{q(x)+1}}{q(x)+1} \right] dx. \end{aligned} \quad (4.9)$$

Fix an index n large enough such that $|\nabla t_n \omega_n| < 1$ and $|t_n \omega_n| < 1$, in $B_R(0)$. Since the function $f(s) = s^{-1}a^s$ is decreasing in $(0, +\infty)$, if $0 < a < 1$, the integrals

$$\begin{aligned} &\int_{\{|x| \leq R\}} \left[\frac{|t_n \nabla \omega_n|^{p(x)}}{p(x)} - \frac{|t_n \nabla \omega_n|^m}{m} \right] dx, \\ &\int_{\{|x| \leq R\}} \left[\frac{|t_n \omega_n|^{p(x)}}{p(x)} - \frac{|t_n \omega_n|^m}{m} \right] dx, \\ &\int_{\{|x| \leq R\}} \left[\frac{|t_n \omega_n|^{s+1}}{s+1} - \frac{|t_n \omega_n|^{q(x)+1}}{q(x)+1} \right] dx \end{aligned}$$

are negative. Observe that from (4.9)

$$c_\lambda \leq c_\infty - A_n + \int_{\{|x| \geq R\}} \left[\frac{|t_n \omega_n|^{s+1}}{s+1} - \frac{|t_n \omega_n|^{q(x)+1}}{q(x)+1} \right] dx, \quad (4.10)$$

where

$$\begin{aligned} -A_n &= \int_{\{|x| \leq R\}} \left[\frac{|t_n \nabla \omega_n|^{p(x)}}{p(x)} - \frac{|t_n \nabla \omega_n|^m}{m} \right] dx + \int_{\{|x| \leq R\}} \left[\frac{|t_n \omega_n|^{p(x)}}{p(x)} - \frac{|t_n \omega_n|^m}{m} \right] dx \\ &\quad + \lambda \int_{\{|x| \leq R\}} \left[\frac{|t_n \omega_n|^{s+1}}{s+1} - \frac{|t_n \omega_n|^{q(x)+1}}{q(x)+1} \right] dx < 0. \end{aligned}$$

At this moment it is important to observe that $A_n = A_n(\omega, R, n, p(x), m)$. For the remaining term in (4.10), using similar arguments as in the proof of the Lemma 4.2, we have

$$\begin{aligned} &\int_{\{|x| \geq R\}} \left[\frac{|t_n \omega_n|^{s+1}}{s+1} - \frac{|t_n \omega_n|^{q(x)+1}}{q(x)+1} \right] dx \\ &\leq C \int_{\{|x| \geq R\}} \left[|t_n \omega_n|^m + |t_n \omega_n|^{p^*(x)} \right] |q(x) - s| dx, \end{aligned}$$

and condition (Q_3) implies that

$$\int_{\{|x| \geq R\}} \left[\frac{|t_n \omega_n|^{s+1}}{s+1} - \frac{|t_n \omega_n|^{q(x)+1}}{q(x)+1} \right] dx \leq C e^{-\gamma} \int_{\{|x| \geq R\}} \left[|t_n \omega_n|^m + |t_n \omega_n|^{p^*(x)} \right] dx. \quad (4.11)$$

Combining the inequalities (4.10) and (4.11) we have

$$c_\lambda \leq c_\infty - A_n + C e^{-\gamma}.$$

Choosing γ large enough, we see that $c_\lambda < c_\infty$. \square

Theorem 4.3 *Assume that (Q_3) holds. Then, there is a $\gamma^* > 0$ such that problem (P_λ) has a ground state solution for all $\gamma > \gamma^*$.*

Proof. The proof follows with arguments similar to the ones explored in the above sections. \square

4.4. Fourth Case: Asymptotical to the Critical Exponent 2^* at Infinity

In this subsection, let us consider the problem

$$\begin{cases} -\Delta_{p(x)} u = u^{q(x)} & \text{in } \mathbb{R}^N, \\ u \geq 0, u \neq 0 & \text{and } u \in D^{1,p(x)}(\mathbb{R}^N), \end{cases} \quad (P_*)$$

where the functions $q = q(r)$ and $p = p(r)$, $r = |x|$, are assumed to be radially symmetric.

We start our study by considering first that the functions satisfy (H_4) for $m = 2$ and $q(x) \leq 2^* - 1$ a.e in \mathbb{R}^N . Moreover, we will assume also the conditions

$$q(x) = 2^* - 1 \text{ for } |x| \leq \delta \text{ or } |x| \geq R, \delta < R, \quad (Q_5)$$

and

$$p(x) = 2 \text{ for } |x| \leq \delta \text{ or } |x| \geq R, \delta < R. \quad (H_5)$$

Considering the Euler–Lagrange functionals

$$J(v) = \int_{\mathbb{R}^N} \frac{|\nabla v|^{p(x)}}{p(x)} dx - \int_{\mathbb{R}^N} \frac{v_+^{q(x)+1}}{q(x)+1} dx, \quad v \in D^{1,p(x)}(\mathbb{R}^N)$$

and

$$J_\infty(v) = \int_{\mathbb{R}^N} \frac{|\nabla v|^2}{2} dx - \int_{\mathbb{R}^N} \frac{v_+^{2^*}}{2^*} dx, \quad v \in D^{1,2}(\mathbb{R}^N)$$

as in the previous cases, J and J_∞ satisfy the Mountain Pass Geometry, and then there is a Palais–Smale sequence $\{u_n\}$ in $D_{rad}^{1,p(x)}(\mathbb{R}^N)$ such that $J(u_n)$ converges to c , minimax level of functional J and such that $J'(u_n) \rightarrow 0$.

Lemma 4.5 *The $(PS)_c$ sequence $\{u_n\}$ is bounded and there exists a subsequence still denoted by $\{u_n\}$ such that*

- $u_n \rightharpoonup u$ in $D_{rad}^{1,p(x)}(\mathbb{R}^N)$ and $D_{rad}^{1,2}(\mathbb{R}^N)$
- $\nabla u_n(x) \rightarrow \nabla u(x)$ a.e. in \mathbb{R}^N
- $u_n(x) \rightarrow u(x)$ a.e. in \mathbb{R}^N .

Proof. Let $\phi \in C_{o,rad}^\infty(\mathbb{R}^N)$ be such that $\phi = 0$ if $|x| \leq R_1$, $\phi = 1$ if $2R_1 \leq |x| \leq 2R_2$, $\phi = 0$ if $|x| \geq 3R_2$ and $0 \leq \phi \leq 1$. Since

$$C|\nabla u_n - \nabla u|^{p(x)} \leq \langle |\nabla u_n|^{p(x)-2} \nabla u_n - |\nabla u|^{p(x)-2} \nabla u, \nabla u_n - \nabla u \rangle, \quad (4.12)$$

for some constant $C > 0$, integrating (4.12) in the set

$$A_{R_1, R_2} = \left\{ x \in \mathbb{R}^N; 2R_1 \leq |x| \leq 2R_2 \right\}$$

results in

$$C \int_{A_{R_1, R_2}} |\nabla u_n - \nabla u|^{p(x)} dx \leq \int_{A_{R_1, R_2}} \langle |\nabla u_n|^{p(x)-2} \nabla u_n - |\nabla u|^{p(x)-2} \nabla u, \nabla u_n - \nabla u \rangle dx.$$

Denoting

$$P_n(x) = \langle |\nabla u_n|^{p(x)-2} \nabla u_n - |\nabla u|^{p(x)-2} \nabla u, \nabla u_n - \nabla u \rangle$$

we have

$$\begin{aligned} \int_{A_{R_1, R_2}} P_n dx &\leq I'_\lambda(u_n)(\phi u_n) - I'_\lambda(u_n)(\phi u) - \int_{\mathbb{R}^N} |\nabla u_n|^{p(x)-2} u_n \nabla u_n \nabla \phi \\ &\quad + \int_{\mathbb{R}^N} |\nabla u_n|^{p(x)-2} u \nabla u_n \nabla \phi - \int_{\mathbb{R}^N} \phi |u_n|^{p(x)} + \int_{\mathbb{R}^N} \phi |u_n|^{q(x)+1} \\ &\quad + \int_{\mathbb{R}^N} \phi |u_n|^{p(x)-2} u_n u - \int_{\mathbb{R}^N} \phi |u_n|^{q(x)-2} u_n u. \end{aligned}$$

Hence by Strauss's Lemma

$$\lim_{n \rightarrow \infty} \int_{A_{R_1, R_2}} P_n dx = 0$$

which implies that u_n converges to u in $W^{1,p(x)}(A_{R_1, R_2})$ for all $R_1, R_2 > 0$, and thus $\nabla u_n(x) \rightarrow \nabla u(x)$ and $u_n(x) \rightarrow u(x)$ a.e in \mathbb{R}^N . \square

Lemma 4.6 *Let $\{u_n\}$ be a $(PS)_c$ sequence for J converging weakly to 0 in $D^{1,p(x)}(\mathbb{R}^N)$. Assume that (H_5) and (Q_5) hold. Then*

$$c \geq \frac{1}{N} S^{\frac{N}{2}},$$

where S is the best constant in the Sobolev immersion $D^{1,2}(\mathbb{R}^N) \hookrightarrow L^{2^*}(\mathbb{R}^N)$.

Proof. We proceed as in Proposition 4.1 and Lemma 4.2, using Lemma 4.5. Let $A_{R,\delta}$ be the annulus $\delta \leq |x| \leq R$. Then we have

$$\begin{aligned} J'(u_n).u_n - J'_\infty(u_n).u_n &= \int_{A_{R,\delta}} [|\nabla u_n|^{p(x)} - |\nabla u_n|^2] dx \\ &\quad + \int_{A_{R,\delta}} [|u_n|^{2^*} - |u_n|^{q(x)+1}] dx, \end{aligned}$$

and then

$$\begin{aligned} |J'(u_n).u_n - J'_\infty(u_n).u_n| &\leq \int_{A_{R,\delta}} |\nabla u_n|^{p(x)} dx + \int_{A_{R,\delta}} |\nabla u_n|^2 dx \\ &\quad + \int_{A_{R,\delta}} |u_n|^{2^*} + \int_{A_{R,\delta}} |u_n|^{q(x)+1} dx. \end{aligned}$$

Using the Strauss immersion: $D_{rad}^{1,2}(\mathbb{R}^N) \hookrightarrow L^q(A_{R,\delta})$, for all $q > 1$, hence $u_n \rightarrow 0$ in $L^{2^*}(A_{R,\delta})$ and then

$$J'(u_n).u_n - J'_\infty(u_n).u_n = o_n(1).$$

In the same way we have $J(u_n) - J_\infty(u_n) = o_n(1)$. As in Lemma 4.2, these facts imply that

$$c \geq \frac{1}{N} S^{\frac{N}{2}}. \quad \square$$

Lemma 4.7 *If (H_5) and (Q_5) hold, we have*

$$c < \frac{1}{N} S^{\frac{N}{2}}.$$

Proof. For each $\varepsilon > 0$, consider the function

$$\omega_\varepsilon(x) = \frac{[N(N-2)\varepsilon]^{\frac{N-2}{4}}}{\left(\varepsilon + |x|^2\right)^{\frac{N-2}{2}}}.$$

We recall that a 1-parameter family $\{\omega_\varepsilon\}_{\varepsilon>0}$ satisfies the problem

$$\begin{cases} -\Delta u = u^{2^*-1}, & \mathbb{R}^N \\ u(x) > 0, \int_{\mathbb{R}^N} |\nabla u|^2 dx < \infty \end{cases}$$

and

$$\int_{\mathbb{R}^N} |\nabla \omega_\varepsilon|^2 dx^2 = \int_{\mathbb{R}^N} \omega_\varepsilon^{2^*} dx = S^{\frac{N}{2}} \quad (\text{see Talenti [8]}).$$

For each $\varepsilon > 0$, let us denote by t_ε the real number such that

$$J(t_\varepsilon \omega_\varepsilon) = \max_{t>0} J(t \omega_\varepsilon).$$

Using the fact that $p(x) \geq 2$ and $q(x) \leq 2^* - 1$ in \mathbb{R}^N , we have that t_ε is bounded as $\varepsilon \rightarrow \infty$. In what follows, we fix $\varepsilon > 0$ sufficiently large such that $|t_\varepsilon \omega_\varepsilon|, |\nabla(t_\varepsilon \omega_\varepsilon)| < 1$.

From the definition of c , we have

$$\begin{aligned} c &\leq J(t_\varepsilon \omega_\varepsilon) = J_\infty(t_\varepsilon \omega_\varepsilon) + J(t_\varepsilon \omega_\varepsilon) - J_\infty(t_\varepsilon \omega_\varepsilon) \\ &\leq \frac{1}{N} S^{\frac{N}{2}} + \int_{\{\delta \leq |x| \leq R\}} \left[\frac{|t_\varepsilon \nabla \omega_\varepsilon|^{p(x)}}{p(x)} - \frac{|t_\varepsilon \nabla \omega_\varepsilon|^2}{2} \right] dx \\ &\quad + \int_{\{\delta \leq |x| \leq R\}} \left[\frac{|t_\varepsilon \omega_\varepsilon|^{2^*}}{2^*} - \frac{|t_\varepsilon \omega_\varepsilon|^{q(x)+1}}{q(x)+1} \right] dx. \end{aligned} \quad (4.13)$$

Since the function $f(s) = s^{-1} a^s$ is decreasing in $s > 0$, when $0 < a < 1$, the terms

$$\begin{aligned} &\int_{\{\delta \leq |x| \leq R\}} \left[\frac{|t_\varepsilon \nabla \omega_\varepsilon|^{p(x)}}{p(x)} - \frac{|t_\varepsilon \nabla \omega_\varepsilon|^p}{p} \right] dx, \\ &\int_{\{\delta \leq |x| \leq R\}} \left[\frac{|t_\varepsilon \omega_\varepsilon|^{s+1}}{s+1} - \frac{|t_\varepsilon \omega_\varepsilon|^{q(x)+1}}{q(x)+1} \right] dx \end{aligned}$$

are negative, and from (4.13), we have that $c < \frac{1}{N} S^{\frac{N}{2}}$. \square

Theorem 4.4 *If (H_5) and (Q_5) hold, problem (P_*) has a solution.*

Proof. For each $\phi \in C_{\alpha, rad}^\infty(\mathbb{R}^N)$, the $(PS)_c$ sequence $\{u_n\}$ satisfies

$$\int_{\mathbb{R}^N} |\nabla u_n|^{p(x)-2} \nabla u_n \cdot \nabla \phi dx = \int_{\mathbb{R}^N} |u_n|^{q(x)-1} u_n \phi dx + o_n(1). \quad (4.14)$$

From Lemma 4.1, by taking the limit in (4.14) we have

$$\int_{\mathbb{R}^N} |\nabla u|^{p(x)-2} \nabla u \cdot \nabla \phi dx = \int_{\mathbb{R}^N} |u|^{q(x)-1} u \phi dx,$$

thus u is a nontrivial critical point of I in $D_{rad}^{1,p(x)}(\mathbb{R}^N)$. Using a principle of symmetric criticality for Banach spaces due de Morais Filho, do Ó and Souto [3], we have that u is a nontrivial critical point of J in $D^{1,p(x)}(\mathbb{R}^N)$, consequently u is a solution for (P_*) . \square

Asymptotical Critical Case

In what follows, let us consider the problem (P_*) assuming again that q and p are radially symmetric functions, (H_2) holds, and we assume that q satisfies also the hypothesis

$$q(x) = 2^* - 1 \text{ a.e in } B_\delta(0), \text{ for some } \delta > 0 \quad (Q_6)$$

and

$$|q(x) - 2^* + 1| \leq C e^{-\theta|x|} \quad \forall x \in \mathbb{R}^N. \quad (Q_7)$$

Repeating the same arguments of the last subsection, the functionals J and J_∞ satisfy the Mountain Pass Geometry, hence there is a Palais-Smale sequence $\{u_n\}$ in $D_{rad}^{1,p(x)}(\mathbb{R}^N)$ such that

$$J(u_n) \rightarrow c \text{ and } J'(u_n) \rightarrow 0$$

where c is the minimax level of the functional J .

It is easy to check that Lemma 4.7 and its proof also can be applied in this case

Lemma 4.8 *Let $\{u_n\}$ be a $(PS)_c$ sequence for J converging weakly to 0 in $D_{rad}^{1,p(x)}(\mathbb{R}^N)$ and assume that (H_5) , (Q_6) and (Q_7) hold. Then,*

$$c \geq \frac{1}{N} S^{\frac{N}{2}}.$$

Proof. We proceed as in Lemmas 4.2, 4.4, and 4.7. Let $A_{R,\delta}$ be the annulus $\delta \leq |x| \leq R$. Then we have

$$\begin{aligned} J'(u_n).u_n - J'_\infty(u_n).u_n &= \int_{A_{R,\delta}} [|\nabla u_n|^{p(x)} - |\nabla u_n|^2] dx \\ &\quad + \int_{|x| \geq \delta} [|u_n|^{2^*} - |u_n|^{q(x)+1}] dx, \end{aligned}$$

and from (Q_7) we have

$$\begin{aligned} |J'(u_n).u_n - J'_\infty(u_n).u_n| &\leq \int_{A_{R,\delta}} |\nabla u_n|^{p(x)} dx + \int_{A_{R,\delta}} |\nabla u_n|^2 dx \\ &\quad + \int_{A_{R,\delta}} |u_n|^{2^*} + \int_{A_{R,\delta}} |u_n|^{q(x)+1} dx \\ &\quad + C e^{-\theta R} \int_{|x| \geq R} [|u_n|^{2^*} + |u_n|^2] dx. \end{aligned} \quad (4.15)$$

Using again the immersion: $D_{rad}^{1,2}(\mathbb{R}^N) \hookrightarrow L^q(A_{R,\delta})$, for all $q > 1$, it follows that $u_n \rightarrow 0$ in $L^{2^*}(A_{R,\delta})$, and from (4.15),

$$J'(u_n).u_n - J'_\infty(u_n).u_n = o_n(1).$$

In the same way, we have $J(u_n) - J_\infty(u_n) = o_n(1)$. As in the Lemma 4.7, these facts imply that

$$c \geq \frac{1}{N} S^{\frac{N}{2}}. \quad \square$$

Lemma 4.9 *If (H_5) , (Q_5) and (Q_6) hold, there exists $\theta^* > 0$ such that*

$$c < \frac{1}{N} S^{\frac{N}{2}}.$$

for all $\theta > \theta^*$.

Proof. Let ω_ε be defined in the Lemma 4.7. As in that lemma, t_ε is such that

$$J(t_\varepsilon \omega_\varepsilon) = \max_{t>0} J(t \omega_\varepsilon).$$

We have

$$\begin{aligned} c &\leq J(t_\varepsilon \omega_\varepsilon) = J_\infty(t_\varepsilon \omega_\varepsilon) + J(t_\varepsilon \omega_\varepsilon) - J_\infty(t_\varepsilon \omega_\varepsilon) \\ &\leq \frac{1}{N} S^{\frac{N}{2}} + \int_{\{\delta \leq |x| \leq R\}} \left[\frac{|t_\varepsilon \nabla \omega_\varepsilon|^{p(x)}}{p(x)} - \frac{|t_\varepsilon \nabla \omega_\varepsilon|^2}{2} \right] dx \\ &\quad + \int_{\{\delta \leq |x|\}} \left[\frac{|t_\varepsilon \omega_\varepsilon|^{2^*}}{2^*} - \frac{|t_\varepsilon \omega_\varepsilon|^{q(x)+1}}{q(x)+1} \right] dx \\ &\leq \frac{1}{N} S^{\frac{N}{2}} - A_\varepsilon + \int_{\{|x| \geq \delta\}} \left[\frac{|t_\varepsilon \omega_\varepsilon|^{2^*}}{2^*} - \frac{|t_\varepsilon \omega_\varepsilon|^{q(x)+1}}{q(x)+1} \right] dx, \end{aligned} \quad (4.16)$$

where

$$-A_\varepsilon = \int_{\{\delta \leq |x| \leq R\}} \left[\frac{|t_\varepsilon \nabla \omega_\varepsilon|^{p(x)}}{p(x)} - \frac{|t_\varepsilon \nabla \omega_\varepsilon|^2}{2} \right] dx.$$

Fix an ε large enough such that $|\nabla(t_\varepsilon \omega_\varepsilon)| < 1$ and $|t_\varepsilon \omega_\varepsilon| < 1$. Since the function $f(s) = s^{-1} a^s$ is decreasing in $s > 0$, if $0 < a < 1$, the terms

$$\begin{aligned} &\int_{\{\delta \leq |x| \leq R\}} \left[\frac{|t_\varepsilon \nabla \omega_\varepsilon|^{p(x)}}{p(x)} - \frac{|t_\varepsilon \nabla \omega_\varepsilon|^2}{2} \right] dx, \\ &\int_{\{\delta \leq |x| \leq R\}} \left[\frac{|t_\varepsilon \omega_\varepsilon|^{2^*}}{2^*} - \frac{|t_\varepsilon \omega_\varepsilon|^{q(x)+1}}{q(x)+1} \right] dx \end{aligned}$$

are negative, and then, $A_\varepsilon > 0$. Observe that

$$\int_{\{|x| \geq R\}} \left[\frac{|t_\varepsilon \omega_\varepsilon|^{2^*}}{2^*} - \frac{|t_\varepsilon \omega_\varepsilon|^{q(x)+1}}{q(x)+1} \right] dx \leq C e^{-\theta R} \int_{\{|x| \geq R\}} \left[|\omega_\varepsilon|^2 + |\omega_\varepsilon|^{2^*} \right] dx.$$

We have

$$c \leq \frac{1}{N} S^{\frac{N}{2}} - A_\varepsilon + C e^{-\theta R}$$

where C is independent of ε . Thus, we conclude that $c < \frac{1}{N} S^{\frac{N}{2}}$, for some $\theta > 0$. \square

Theorem 4.5 *Assume that (H_5) , (Q_5) and (Q_6) hold. Then, there is a $\theta^* > 0$ such that Problem (P_*) has a solution for all $\theta > \theta^*$.*

Proof. The proof follows from the last lemmas and of similar arguments explored in the above sections. \square

Final commentaries. Using the techniques explored in this paper, it is possible to prove similar results for a large class of nonlinearities. Moreover, if the functions $p(x)$ and $q(x)$ are Z -periodic, that is,

$$p(x + y) = p(x) \text{ and } q(x + y) = q(x) \quad \forall x \in \mathbb{R}^N \text{ and } y \in Z^N$$

adapting arguments explored in [2], it is possible to prove also the existence of solution to (P) for the subcritical case.

References

- [1] C.O. Alves, Existência de solução positiva de equações elípticas não-lineares variacionais em \mathbb{R}^N , Ph.D. Thesis, Universidade de Brasília, Brasília, 1996.
- [2] C.O. Alves, J.M. do Ó and O.H. Miyagaki, On perturbations of a class of a periodic m -Laplacian equation with critical growth, *Nonlinear Analysis* **45** (2001), 849-863.
- [3] D. C. de Moraes Filho, J.M. do Ó and M.A.S. Souto, A Compactness Embedding Lemma, a Principle of Symetric Criticality and Applications to Elliptic Problems, Publicado no Proyecciones — *Revista Matemática* **19**, no. 1 (2000), 1-17.
- [4] X.L. Fan, J.S. Shen and D. Zhao, Sobolev embedding theorems for spaces $W^{k,p(x)}(\Omega)$, *J. Math. Anal. Appl.* **262** (2001), 749-760.
- [5] X.L. Fan, Y.Z. Zhao and D. Zhao, Compact embedding theorems with symmetry of Strauss-Lions type for the space $W^{1,p(x)}(\Omega)$, *J. Math. Anal. Appl.* **255** (2001), 333-348
- [6] X.L. Fan and D. Zhao, On the spaces $L^{p(x)}(\Omega)$ and $W^{m,p(x)}(\Omega)$, *J. Math. Anal. Appl.* **263** (2001), 424-446
- [7] X.L. Fan and Q.H. Zhang, Existence of solutions for $p(x)$ -Laplacian Dirichlet problem, *Nonlinear Analysis* **52** (2003), 1843-1852.
- [8] G. Talenti, Best constant in Sobolev inequality. *Ann. Mat. Pura Appl.* **110** (1976), 353-372.
- [9] M. Willem, Minimax Theorems, Progress in Nonlinear Differential Equations and Their Applications, vol. 24, Birkhauser Boston, 1996.

Claudianor O. Alves and Marco A.S. Souto
 Universidade Federal de Campina Grande
 Departamento de Matemática e Estatística
 Cep: 58109-970, Campina Grande – Pb
 Brazil

e-mail: coalves@dme.ufcg.edu.br
 marco@dme.ufcg.edu.br

A Unitarian Approach to Classical Electrodynamics: The Semilinear Maxwell Equations

Vieri Benci and Donato Fortunato

Dedicated to our friend Djairo

1. Introduction

The study of the relation of matter and the electromagnetic field is a classical, intriguing problem both from physical and mathematical point of view. In the framework of a classical relativistic theory particles must be considered pointwise. However charged pointwise particles have infinite energy and therefore infinite inertial mass. This fact gives rise to well known difficulties (see for example [10], [11], [12]). The use of nonlinear equations in classical electrodynamics permits in some situations to avoid these difficulties. In section 2 we shall briefly review some basic facts on Maxwell equations and on the nonlinear Born-Infeld theory (see [8], [7], [6]).

In section 3 we consider a semilinear perturbation of Maxwell equations (SME) introduced in [1]. This model deals with classical electrodynamics without touching any question related to quantum theory.

The main peculiarities of this theory are the following ones:

- It interprets the relation between matter and electromagnetic fields from a unitarian standpoint according to the meaning given in [8]: only one physical entity is assumed, the electromagnetic field. Matter particles are solitary waves of SME due to the presence of the nonlinearity.
- The equations are variational and invariant for the Poincaré group. Then the energy and the momentum are constants of the motion (see subsection 3.1) and the basic principles of special relativity hold; in particular inertial mass equals energy (see subsection 3.3).
- By the presence of the nonlinear term the equations of this theory are not gauge invariant. We point out that the gauge invariance is destroyed only in

the region (see (38)) where the solitary wave is "concentrated" (the matter) and it is preserved outside the matter, i.e. in the region where the nonlinear term is negligible so that we have essentially the Maxwell equations in the empty space.

- Although the equations are not gauge invariant, the total charge is a constant of the motion (see subsection 3.1).
- Any matter particle (charged or not) carries an intrinsic magnetic moment; this is a kind of classical analogue of the spin (see proposition 3 and remark 4).

The main attention is devoted to static solutions of (SME). We cannot exhibit explicit static solutions and their existence is proved by using a suitable variational approach. In particular we study the magnetostatic case (i.e. the case in which the electric field $\mathbf{E} = 0$ and the magnetic field \mathbf{H} does not depend on time). In this case SME are reduced to the nonlinear, elliptic, degenerate equation

$$\nabla \times \nabla \times \mathbf{A} = f'(\mathbf{A}) \quad (1)$$

where $\nabla \times$ denotes the *curl* operator, f' is the gradient of a strictly convex smooth function $f: \mathbf{R}^3 \rightarrow \mathbf{R}$ and $\mathbf{A}: \mathbf{R}^3 \rightarrow \mathbf{R}^3$ is the gauge potential related to the magnetic field \mathbf{H} ($\mathbf{H} = \nabla \times \mathbf{A}$).

The main difficulty in dealing with the above equation relies in the fact that the energy related to it,

$$\mathcal{E}(\mathbf{A}) = \int \left(\frac{1}{2} |\nabla \times \mathbf{A}|^2 - f(\mathbf{A}) \right) dx, \quad (2)$$

does not yield an a-priori bound on $\|\nabla \mathbf{A}\|_{L^2}$. In particular the functional (2) is strongly indefinite in the sense that it is not bounded from above or from below and any possible critical point \mathbf{A} has infinite Morse index; namely, the second variation of (2),

$$\mathcal{E}''(\mathbf{A})[v, v] = \int \left(|\nabla \times v|^2 - f''(\mathbf{A})[v, v] \right) dx,$$

is negative definite on the infinite dimensional subspace

$$\{v = \nabla \varphi : \varphi \in C_0^\infty(\mathbf{R}^3, \mathbf{R})\}.$$

On the other hand, the nonlinearity $f'(\mathbf{A})$ destroys the gauge invariance of (1). So it is not possible to choose the Coulomb gauge (where $\nabla \cdot \mathbf{A} = 0$) to avoid this indefiniteness.

To overcome the above difficulties we will use a new functional framework related to the Hodge splitting of the vector field \mathbf{A} .

Another difficulty arises from the growth conditions of the nonlinearity $f'(\mathbf{A})$. In fact, physical considerations impose $f'(\mathbf{A})$ to be negligible when $|\mathbf{A}|$ is small, and large when $|\mathbf{A}| \geq 1$ (see the remarks on assumption **W1** in section 3). So it is assumed (see (57)–(60)) that

$$f(\mathbf{A}) \simeq |\mathbf{A}|^q \quad (q > 6) \text{ for } |\mathbf{A}| \leq 1$$

and

$$f(\mathbf{A}) \simeq |\mathbf{A}|^p \quad (2 < p < 6) \text{ for } |\mathbf{A}| \geq 1.$$

This fact leads to study the problem in the function space

$$\mathcal{D} := \left\{ u \in L^6 : \int |\nabla u|^2 dx < +\infty \right\}$$

and in the Orlicz space $L^p + L^q$ in which \mathcal{D} is continuously embedded. The sketch of the proof of the existence theorem is contained in the last section.

2. Basic facts

2.1. The Maxwell equations

First we recall some basic facts on Maxwell equations. The Maxwell equations for an electromagnetic field $\mathbf{E} = \mathbf{E}(t, x)$, $\mathbf{H} = \mathbf{H}(t, x)$ ($t \in \mathbf{R}$, $x \in \mathbf{R}^3$ are the time and space variables respectively) are

$$\nabla \times \mathbf{H} - \frac{\partial \mathbf{E}}{\partial t} = \mathbf{J} \quad (3)$$

$$\nabla \cdot \mathbf{E} = \rho \quad (4)$$

$$\frac{\partial \mathbf{H}}{\partial t} + \nabla \times \mathbf{E} = 0 \quad (5)$$

$$\nabla \cdot \mathbf{H} = 0. \quad (6)$$

$\rho = \rho(t, x)$ and $\mathbf{J} = \mathbf{J}(t, x)$ are respectively a scalar and a vector valued function which represent the charge and the current density of an external source. Here and in the following we assume c (light velocity) = 1.

In the empty space

$$\rho = 0, \mathbf{J} = 0.$$

The first three equations (3), (4) and (5) are respectively the Ampère, Gauss and Faraday laws.

Observe that from (3) we get

$$\frac{\partial \nabla \cdot \mathbf{E}}{\partial t} + \nabla \cdot \mathbf{J} = 0.$$

Then, using (4), we get that ρ and \mathbf{J} are related by the continuity equation

$$\frac{\partial \rho}{\partial t} + \nabla \cdot \mathbf{J} = 0.$$

Now introduce the gauge potentials \mathbf{A} , φ which permit to write (3), (4) as second order equations and to satisfy identically (5) and (6). \mathbf{A} , φ are related to \mathbf{E} and \mathbf{H} by

$$\mathbf{H} = \nabla \times \mathbf{A} \quad (7)$$

$$\mathbf{E} = -\frac{\partial \mathbf{A}}{\partial t} - \nabla \varphi.$$

Then the first two Maxwell equations (3) and (4) can be written as

$$\frac{\partial}{\partial t} \left(\frac{\partial \mathbf{A}}{\partial t} + \nabla \varphi \right) + \nabla \times (\nabla \times \mathbf{A}) = \mathbf{J} \quad (8)$$

$$\nabla \cdot \left(\frac{\partial \mathbf{A}}{\partial t} + \nabla \varphi \right) = -\rho. \quad (9)$$

And the other two equations (5) and (6) are obviously satisfied.

Let $\chi = \chi(t, x)$ be a scalar function, then it is easily verified that the electromagnetic field \mathbf{E} , \mathbf{H} and equations (8), (9) do not change under the gauge transformation

$$\mathbf{A} \rightarrow \mathbf{A} + \nabla \chi, \quad \varphi \rightarrow \varphi - \frac{\partial \chi}{\partial t}.$$

The equations (8), (9) have a variational structure, namely they are the Euler equations of the functional

$$S_m(\varphi, \mathbf{A}) = \int L_m dx dt \quad (10)$$

where L_m is the Lagrangian

$$L_m = \frac{1}{2} \left(\left| \frac{\partial \mathbf{A}}{\partial t} + \nabla \varphi \right|^2 - |\nabla \times \mathbf{A}|^2 \right) + (\mathbf{J} | \mathbf{A}) - \rho \cdot \varphi \quad (11)$$

$$= \frac{1}{2} (|\mathbf{E}|^2 - |\mathbf{H}|^2) + (\mathbf{J} | \mathbf{A}) - \rho \cdot \varphi. \quad (12)$$

The energy of the electromagnetic field is given by (see e.g. [9] sec. 38)

$$\mathcal{E} = \int \left(\frac{\partial L_m}{\partial(\frac{\partial \mathbf{A}}{\partial t})} \cdot \frac{\partial \mathbf{A}}{\partial t} - L_m \right) dx \quad (13)$$

$$\begin{aligned} &= \int \left(\left(\frac{\partial \mathbf{A}}{\partial t} + \nabla \varphi \mid \frac{\partial \mathbf{A}}{\partial t} \right) - \frac{1}{2} \left| \frac{\partial \mathbf{A}}{\partial t} + \nabla \varphi \right|^2 + \frac{1}{2} |\nabla \times \mathbf{A}|^2 \right) dx \\ &+ \int (- (\mathbf{J} | \mathbf{A}) + \rho \varphi) dx. \end{aligned} \quad (14)$$

Now consider the electrostatic case, i.e., assume $\mathbf{A} = 0$, $\mathbf{J} = 0$, $\varphi = \varphi(x)$. Then

$$\mathcal{E} = \int \left(-\frac{1}{2} |\nabla \varphi|^2 + \rho \varphi \right) dx. \quad (15)$$

We can give a simpler expression for \mathcal{E} exploiting the fact that φ solves the equation (see (9))

$$-\Delta \varphi = \rho.$$

In fact, multiplying both sides of the above equation by φ and integrating, we have

$$\int |\nabla \varphi|^2 dx = \int \rho \varphi dx. \quad (16)$$

Inserting (16) in (15) we get

$$\mathcal{E} = \frac{1}{2} \int |\nabla\varphi|^2 dx = \frac{1}{2} \int |\mathbf{E}|^2 dx$$

which is the usual expression for the electrostatic energy.

Now suppose that we want to model matter particles as dimensionless points. In this model, the density ρ of a particle located at 0 is the Dirac measure. Then $\varphi = \frac{1}{|x|}$ and the energy \mathcal{E} diverges. As a consequence, the inertial mass of the particle diverges.

The difficulties presented by this problem touch one of the most fundamental aspects of physics, the nature of an elementary particle. Although partial solutions, workable within limited areas can be given, the basic problems remain unsolved ([10], section 17.1 pag. 579). See also [11], [12].

The divergence of the energy could be avoided if particles are supposed to have a space extension, namely, if matter is modelled as a field. Particles are usually stable; then they need to be described by solutions of a field equations whose energy travels as a localized packet and which preserve this localization property under perturbations. These kind of solutions are usually called solitary waves (or solitons).

In order to build a field equation which presents the existence of solitary waves, there are two possible choices: the dualistic standpoint and the unitarian standpoint. In the dualistic standpoint the matter is described as a field ψ which is the source of the electromagnetic field (\mathbf{E}, \mathbf{H}) and it is itself influenced by (\mathbf{E}, \mathbf{H}) . However it is not part of the electromagnetic field. In [2] the case in which ψ is a complex field related to the nonlinear Klein-Gordon equation is studied.

In this paper we are interested to discuss the unitarian standpoint which assumes only one physical entity, the electromagnetic field. The matter and the electromagnetic field have the same nature and the particles are solitary waves of the field. In the next section we shall briefly review some ideas contained in the celebrated papers by Born and Infeld ([8], [7]). We refer to [13] and [14] for an extensive treatment of this subject.

2.2. The Born-Infeld model

Born and Infeld introduce in ([8], [7]) (see also [6]) a new formulation of the Maxwell equations. They argue as follows: “A satisfactory theory should avoid letting physical quantities become infinite. Applying this principle to the velocity one is led to the assumption of an upper limit of velocity c and to replace the Newtonian action $\frac{1}{2}mv^2$ of a free particle by the relativity expression $mc^2 \left(1 - \sqrt{1 - \frac{v^2}{c^2}}\right)$ ”.

Following the above argument they replace the usual Lagrangian density (11) of the electromagnetic field \mathbf{E} , \mathbf{H} in the empty space (\mathbf{J} and ρ are zero),

$$\mathcal{L} = \frac{1}{2} (\mathbf{E}^2 - \mathbf{H}^2) = \frac{1}{2} \left(\left| \frac{\partial \mathbf{A}}{\partial t} + \nabla \varphi \right|^2 - |\nabla \times \mathbf{A}|^2 \right), \quad (17)$$

by a modified Lagrangian

$$\mathcal{L}_{BI} = b^2 \left(1 - \sqrt{1 - \frac{2\mathcal{L}}{b^2}} \right) \quad (18)$$

where b is a suitable scaling parameter. In the following we assume for simplicity $b = 1$. Clearly the above Lagrangian defines a nonlinear theory of electromagnetism and the classical Maxwell theory is recovered in the weak field limit $\mathbf{E}, \mathbf{H} \rightarrow \mathbf{0}$.

The Euler-Lagrange equations are

$$\nabla \cdot \left(\frac{\mathbf{E}}{\sqrt{1 - 2\mathcal{L}}} \right) = 0 \quad (19)$$

$$\nabla \times \frac{\mathbf{H}}{\sqrt{1 - 2\mathcal{L}}} - \frac{\partial}{\partial t} \left(\frac{\mathbf{E}}{\sqrt{1 - 2\mathcal{L}}} \right) = 0 \quad (20)$$

where

$$\mathbf{H} = \nabla \times \mathbf{A} \text{ and } \mathbf{E} = -\frac{\partial \mathbf{A}}{\partial t} - \nabla \varphi.$$

In view of the fact that (19), (20) are nonlinear it is natural to ask whether there exists a non trivial, finite energy solution in the electrostatic case (i.e., when $\mathbf{A} = 0$ and $\frac{\partial \varphi}{\partial t} = 0$) or in the magnetostatic case (i.e. when $\varphi=0$ and $\frac{\partial \mathbf{A}}{\partial t} = 0$). These solutions should represent self-induced electrostatic or magnetostatic fields without an external source. In the electrostatic case

$$\mathbf{E} = -\nabla \varphi$$

and the Lagrangian is

$$\mathcal{L}_{BI} = 1 - \sqrt{1 - |\nabla \varphi|^2}.$$

Then the energy on the electrostatic fields is

$$\begin{aligned} \mathcal{E}(\varphi) &= \int \left(\frac{\partial \mathcal{L}_{BI}}{\partial \left(\frac{\partial \mathbf{A}}{\partial t} \right)} \cdot \frac{\partial \mathbf{A}}{\partial t} - \mathcal{L}_{BI} \right) dx \\ &= - \int \mathcal{L}_{BI} dx = \int \left(\sqrt{1 - |\nabla \varphi|^2} - 1 \right) dx \end{aligned} \quad (21)$$

and the equation (19) reduces to the equation

$$\nabla \cdot \left(\frac{\nabla \varphi}{\sqrt{1 - |\nabla \varphi|^2}} \right) = 0. \quad (22)$$

In the magnetostatic case the energy is represented by

$$\mathcal{E}(\mathbf{A}) = \int \left(\sqrt{1 + |\nabla \times \mathbf{A}|^2} - 1 \right) dx$$

and the equation (20) reduces to the equation

$$\nabla \times \left(\frac{\nabla \times \mathbf{A}}{\sqrt{1 + |\nabla \times \mathbf{A}|^2}} \right) = 0. \quad (23)$$

It can be shown (see [13]) that the only finite energy solution of (22) (respectively (23)) is $\varphi = 0$ (respectively $\mathbf{A} = \mathbf{0}$).

So there do not exist self-induced electrostatic or magnetostatic fields without an external source; therefore we conclude that the Born-Infeld theory is not unitarian. However this theory avoids the divergence, in fact it can be verified that the field

$$\mathbf{E}(\mathbf{x}) = \frac{1}{\sqrt{1 + |\mathbf{x}|^4}} \frac{\mathbf{x}}{|\mathbf{x}|} \quad (24)$$

solves the nonhomogeneous equation

$$\nabla \cdot \left(\frac{\mathbf{E}}{\sqrt{1 - \mathbf{E}^2}} \right) = \delta$$

where δ is the delta distribution describing a pointwise unitary charge. Moreover it is easy to verify that the solution (24) has finite energy, it is globally bounded and it approximates the Coulomb field $\frac{\mathbf{x}}{|\mathbf{x}|^3}$ for $|\mathbf{x}|$ large.

3. The semilinear Maxwell equations

Here we report some results contained in [1] where a unitarian field theory, based on a semilinear perturbation of the Maxwell equations, has been introduced.

We modify the usual Maxwell action in the empty space

$$S_m(\varphi, \mathbf{A}) = \frac{1}{2} \int \int \left[\left| \frac{\partial \mathbf{A}}{\partial t} + \nabla \varphi \right|^2 - |\nabla \times \mathbf{A}|^2 \right] dxdt$$

in the following way:

$$\mathcal{S} = \frac{1}{2} \int \int \left[\left| \frac{\partial \mathbf{A}}{\partial t} + \nabla \varphi \right|^2 - |\nabla \times \mathbf{A}|^2 + W(|\mathbf{A}|^2 - \varphi^2) \right] dxdt \quad (25)$$

where $W : \mathbf{R} \rightarrow \mathbf{R}$.

The argument of W is $|\mathbf{A}|^2 - |\varphi|^2$ in order to make this expression invariant for the Poincaré group and the equations consistent with special relativity.

Making the variation of \mathcal{S} with respect to $\delta\mathbf{A}$, $\delta\varphi$, respectively, we get the equations

$$\frac{\partial}{\partial t} \left(\frac{\partial \mathbf{A}}{\partial t} + \nabla \varphi \right) + \nabla \times (\nabla \times \mathbf{A}) = W' \left(|\mathbf{A}|^2 - \varphi^2 \right) \mathbf{A} \quad (26)$$

$$-\nabla \cdot \left(\frac{\partial \mathbf{A}}{\partial t} + \nabla \varphi \right) = W' \left(|\mathbf{A}|^2 - \varphi^2 \right) \varphi. \quad (27)$$

If we set

$$\mathbf{H} = \nabla \times \mathbf{A} \quad (28)$$

$$\mathbf{E} = -\frac{\partial \mathbf{A}}{\partial t} - \nabla \varphi \quad (29)$$

$$\rho = W' \left(|\mathbf{A}|^2 - \varphi^2 \right) \varphi \quad (30)$$

$$\mathbf{J} = W' \left(|\mathbf{A}|^2 - \varphi^2 \right) \mathbf{A}, \quad (31)$$

we get the equations

$$\nabla \times \mathbf{H} - \frac{\partial \mathbf{E}}{\partial t} = \mathbf{J}(\mathbf{A}, \varphi) \quad (32)$$

$$\nabla \cdot \mathbf{E} = \rho(\mathbf{A}, \varphi) \quad (33)$$

$$\nabla \times \mathbf{E} + \frac{\partial \mathbf{H}}{\partial t} = 0 \quad (34)$$

$$\nabla \cdot \mathbf{H} = 0 \quad (35)$$

which, formally, are the Maxwell equations in the presence of matter if we interpret $\rho(\mathbf{A}, \varphi)$ as charge density and $\mathbf{J}(\mathbf{A}, \varphi)$ as current density. Notice that ρ and \mathbf{J} are not assigned functions representing external sources: they depend on the gauge potentials, so that we are in the presence of a unitarian theory. Hereafter the system (26), (27) (or (32)–(35)) will be called SME.

Now we make the following assumption on W :

- **(W1)** there exist two positive constants $\varepsilon_1, \varepsilon_2 \ll 1$ such that

$$|W'(s)| \leq \varepsilon_1 |s| \quad \text{for } |s| \leq 1; \quad (36)$$

$$|W'(s)| \geq 1 \quad \text{for } |s| \geq 1 + \varepsilon_2. \quad (37)$$

We set

$$\Omega_t(\mathbf{A}, \varphi) = \left\{ x \in \mathbf{R}^3 : \left| |\mathbf{A}(t, x)|^2 - \varphi(t, x)^2 \right| \geq 1 \right\}. \quad (38)$$

Ω_t represents the portion of space filled with matter at time t . Assumption (36) implies that ρ and \mathbf{J} become negligible outside Ω_t and the above equations can be interpreted as the Maxwell equations in the empty space.

Assumption (37) implies that ρ and \mathbf{J} become strong inside Ω_t , at least in the region where $\left| |\mathbf{A}(t, x)|^2 - \varphi(t, x)^2 \right| \geq 1 + \varepsilon_2$.

3.1. Invariants of motion

The action (25) is invariant under the Poincarè group. This group depends on ten parameters. Then, by Noether's theorem, there are ten constants of the motion: the energy \mathcal{E} , the momentum $\mathbf{P} = (P_1, P_2, P_3)$, the angular momentum $\mathbf{M} = (M_1, M_2, M_3)$ and the velocity $\mathbf{v} = (v_1, v_2, v_3)$ of the ergocenter. These invariants of the motion are analyzed in [3]. Here we shall only write the expressions of the energy and of the momentum.

- **Energy:**

$$\mathcal{E}(\mathbf{A}, \varphi) = \frac{1}{2} \int \left(\left| \frac{\partial \mathbf{A}}{\partial t} \right|^2 - |\nabla \varphi|^2 + |\nabla \times \mathbf{A}|^2 - W(|\mathbf{A}|^2 - \varphi^2) \right) dx. \quad (39)$$

- **Momentum:**

$$\mathbf{P}(\mathbf{A}, \varphi) = \int \sum_{i=1}^3 \left(\frac{\partial A_i}{\partial t} + \frac{\partial \varphi}{\partial x_i} \right) \nabla A_i dx. \quad (40)$$

Now let us consider a constant of the motion, the charge, which is not related to the invariance of (25) under the action of the Poincarè group.

The **charge** is defined as

$$C(\mathbf{A}, \varphi) = \int \rho(\mathbf{A}, \varphi) dx = \int W'(|\mathbf{A}|^2 - \varphi^2) \varphi dx. \quad (41)$$

The charge $C = C(\mathbf{A}, \varphi)$ is constant along the solutions \mathbf{A}, φ of (26), (27). In fact, if we take the divergence in (32) and the derivative with respect to t in (33), we easily get the continuity equation

$$\frac{\partial \rho}{\partial t} + \nabla \cdot \mathbf{J} = 0.$$

We can express the energy by a more meaningful expression which will be useful later:

Proposition 1. *The energy of the solutions of SME is*

$$\begin{aligned} \mathcal{E}(\mathbf{A}, \varphi) &= \int \left(\frac{1}{2} |\mathbf{E}|^2 + \frac{1}{2} |\mathbf{H}|^2 - W'(\sigma) \varphi^2 - \frac{1}{2} W(\sigma) \right) dx \\ &= \frac{1}{2} \int (|\mathbf{E}|^2 + |\mathbf{H}|^2) dx - \int \left(\rho \varphi + \frac{1}{2} W(\sigma) \right) dx \end{aligned}$$

where

$$\sigma = |\mathbf{A}|^2 - \varphi^2.$$

Proof. If we multiply Eq. (27) by φ and integrate in x we get

$$\int \left(\frac{\partial \mathbf{A}}{\partial t} \cdot \nabla \varphi + |\nabla \varphi|^2 \right) dx - \int W'(\sigma) \varphi^2 dx = 0.$$

We add this expression to $\mathcal{E}(\mathbf{A}, \varphi)$; then

$$\begin{aligned} \mathcal{E}(\mathbf{A}, \varphi) &= \int \left(\frac{1}{2} \left| \frac{\partial \mathbf{A}}{\partial t} \right|^2 + \frac{1}{2} |\nabla \varphi|^2 + \nabla \varphi \cdot \frac{\partial \mathbf{A}}{\partial t} + \frac{1}{2} |\nabla \times \mathbf{A}|^2 \right. \\ &\quad \left. - W'(\sigma) \varphi^2 - \frac{1}{2} W(\sigma) \right) dx \\ &= \int \left(\frac{1}{2} \left| \frac{\partial \mathbf{A}}{\partial t} + \nabla \varphi \right|^2 + \frac{1}{2} |\nabla \times \mathbf{A}|^2 - W'(\sigma) \varphi^2 - \frac{1}{2} W(\sigma) \right) dx \\ &= \int \left(\frac{1}{2} |\mathbf{E}|^2 + \frac{1}{2} |\mathbf{H}|^2 - W'(\sigma) \varphi^2 - \frac{1}{2} W(\sigma) \right) dx \end{aligned}$$

The second expression for the energy is obtained just using (30). \square

The term

$$\frac{1}{2} \int_{\mathbf{R}^3} (|\mathbf{E}|^2 + |\mathbf{H}|^2) dx$$

represents the energy of the electromagnetic field, while

$$- \int_{\mathbf{R}^3} \left(\frac{1}{2} W(\sigma) + W'(\sigma) \varphi^2 \right) dx = - \int_{\mathbf{R}^3} \left(\rho \varphi + \frac{1}{2} W(\sigma) \right) dx \quad (42)$$

represents the energy of the matter (short range field such as the nuclear fields). It can be interpreted as bond energy and it is “concentrated” essentially in Ω_t .

3.2. Static solutions

We are interested in the static solutions of (26), (27), namely in the solutions \mathbf{A} , φ , depending only on the space variable x , of the following equations:

$$\nabla \times (\nabla \times \mathbf{A}) = W' \left(|\mathbf{A}|^2 - \varphi^2 \right) \mathbf{A} \quad (43)$$

$$-\Delta \varphi = W' \left(|\mathbf{A}|^2 - \varphi^2 \right) \varphi. \quad (44)$$

The static solutions are critical points of the energy functional:

$$\mathcal{E}(\mathbf{A}, \varphi) = \frac{1}{2} \int \left(|\nabla \times \mathbf{A}|^2 - |\nabla \varphi|^2 - W \left(|\mathbf{A}|^2 - \varphi^2 \right) \right) dx. \quad (45)$$

Proposition 2. *If (\mathbf{A}, φ) is a finite energy, static solution of SME, then*

$$\begin{aligned} \mathcal{E}(\mathbf{A}, \varphi) &= \frac{1}{3} \int \left(|\nabla \times \mathbf{A}|^2 - |\nabla \varphi|^2 \right) dx \\ &= \int W \left(|\mathbf{A}|^2 - \varphi^2 \right) dx. \end{aligned}$$

Proof. Let $\lambda > 0$ and set

$$\begin{aligned} \varphi_\lambda(x) &= \varphi(\lambda^{-1}x); \\ \mathbf{A}_\lambda(x) &= \mathbf{A}(\lambda^{-1}x). \end{aligned}$$

Then, setting $y = \lambda^{-1}x$,

$$\begin{aligned} \mathcal{E}(\mathbf{A}_\lambda, \varphi_\lambda) &= \frac{1}{2} \int \left(|\nabla_x \times \mathbf{A}_\lambda(x)|^2 - |\nabla_x \varphi_\lambda(x)|^2 \right) dx \\ &\quad - \frac{1}{2} \int W \left(|\mathbf{A}_\lambda(x)|^2 - \varphi_\lambda(x)^2 \right) dx \\ &= \frac{\lambda}{2} \int \left(|\nabla_y \times \mathbf{A}(y)|^2 - |\nabla_y \varphi(y)|^2 \right) dy \\ &\quad - \frac{\lambda^3}{2} \int W \left(|\mathbf{A}(y)|^2 - \varphi(y)^2 \right) dy. \end{aligned}$$

Since (\mathbf{A}, φ) is a critical point of \mathcal{E} ,

$$\left. \frac{d}{d\lambda} \mathcal{E}(\mathbf{A}_\lambda, \varphi_\lambda) \right|_{\lambda=1} = 0. \quad (46)$$

Let us compute this expression explicitly:

$$\begin{aligned} &\frac{d}{d\lambda} \mathcal{E}(\mathbf{A}_\lambda, \varphi_\lambda) \\ &= \frac{1}{2} \int |\nabla_y \times \mathbf{A}(y)|^2 - |\nabla_y \varphi(y)|^2 dy - \frac{3}{2} \lambda^2 \int W \left(|\mathbf{A}(y)|^2 - \varphi(y)^2 \right) dy. \end{aligned}$$

For $\lambda = 1$, using (46), we get

$$\frac{1}{3} \int \left(|\nabla \times \mathbf{A}|^2 - |\nabla \varphi|^2 \right) dx = \int W \left(|\mathbf{A}|^2 - \varphi^2 \right) dx. \quad (47)$$

Then

$$\begin{aligned} \mathcal{E}(\mathbf{A}, \varphi) &= \frac{1}{2} \int \left(|\nabla \times \mathbf{A}|^2 - |\nabla \varphi|^2 \right) dx - \frac{1}{2} \int W \left(|\mathbf{A}|^2 - \varphi^2 \right) dx \\ &= \frac{1}{3} \int \left(|\nabla \times \mathbf{A}|^2 - |\nabla \varphi|^2 \right) dx. \end{aligned}$$

And by (47) we have also

$$\mathcal{E}(\mathbf{A}, \varphi) = \int W \left(|\mathbf{A}|^2 - \varphi^2 \right) dx. \quad \square$$

By using the Poincaré invariance of (25) it can be deduced that the energy \mathcal{E} of a static solution represents the rest mass (see (55)). Then only those static solutions whose energy is positive are physically interesting. The following proposition gives an interesting necessary condition in order to get solutions with positive energy.

Proposition 3. *Let (\mathbf{A}, φ) be a solution of (43),(44) with finite and positive energy $\mathcal{E}(\mathbf{A}, \varphi)$. Then*

$$\mathbf{J} = W' \left(|\mathbf{A}|^2 - \varphi^2 \right) \mathbf{A} \neq \mathbf{0}.$$

Moreover, there exists a (nontrivial) vector field $\mu = \mu(\mathbf{x})$ (depending on \mathbf{A}, φ) s.t. $\mathbf{J} = \nabla \times \mu$.

Proof. By proposition 2 we have

$$\frac{1}{3} \int |\nabla \times \mathbf{A}|^2 dx \geq \frac{1}{3} \int \left(|\nabla \times \mathbf{A}|^2 - |\nabla \varphi|^2 \right) dx = \mathcal{E}(\mathbf{A}, \varphi) > 0.$$

So

$$\int |\nabla \times \mathbf{A}|^2 dx > 0. \quad (48)$$

Now we argue by contradiction and assume that

$$\mathbf{J} = W'(|\mathbf{A}|^2 - \varphi^2) \mathbf{A} = \mathbf{0}.$$

Then equation (43) becomes

$$\nabla \times (\nabla \times \mathbf{A}) = 0.$$

Multiplying by \mathbf{A} and integrating, we get

$$\int |\nabla \times \mathbf{A}|^2 dx = 0$$

which contradicts (48).

Since \mathbf{A} solves (43), clearly we have $\nabla \cdot \mathbf{J} = \mathbf{0}$. Then there exists a vector field $\mu = \mu(\mathbf{x})$, which is clearly non zero, s.t. $\mathbf{J} = \nabla \times \mu$. \square

Remark 4. The vector field μ is the density of the magnetic moment related to \mathbf{J} . Observe that μ is not trivial also when $\varphi = 0$. Thus any static solution of SME which is physically interesting (i.e., with $\mathcal{E}(\mathbf{A}, \varphi) > 0$) is sensitive to external magnetic fields even if it has no charge. This vector field μ is an intrinsic property of the “particle” and it can be interpreted as the classical analogue of the spin.

In order to get the simplest static solutions, we look for solutions (\mathbf{A}, φ) of (43), (44) of the type

$$(0, \varphi) \text{ (electrostatic case)}$$

$$(\mathbf{A}, 0) \text{ (magnetostatic case)}.$$

With this ansatz, we obtain the following equations:

- **Electrostatic equation:**

$$-\Delta \varphi = W'(-\varphi^2) \varphi; \quad (49)$$

- **Magnetostatic equation:**

$$\nabla \times (\nabla \times \mathbf{A}) = W'(|\mathbf{A}|^2) \mathbf{A}. \quad (50)$$

They correspond to the critical points respectively of the functionals

$$\begin{aligned} \mathcal{E}(\varphi) &= -\frac{1}{2} \int \left(|\nabla \varphi|^2 + W(-\varphi^2) \right) dx \\ \mathcal{E}(\mathbf{A}) &= \frac{1}{2} \int \left(|\nabla \times \mathbf{A}|^2 - W(|\mathbf{A}|^2) \right) dx. \end{aligned} \quad (51)$$

In order to get solutions we need the following assumption:

- **(W2)** there exist positive constants $c_2, c_3 > 0$ such that

$$|W'(s)| \leq c_2 |s|^{p/2-1}; \quad p < 6 \quad \text{for } |s| \geq 1$$

$$|W'(s)| \leq c_3 |s|^{q/2-1}; \quad q > 6 \quad \text{for } |s| \leq 1.$$

We have the following result for the electrostatic equation.

Theorem 5. *Assume that W satisfies (W2). Then (49) possesses a finite energy, nontrivial solution if and only if there exists s_0 such that*

$$W(s_0) < 0. \tag{52}$$

Proof. Since W satisfies (W2) and (52), the if part follows from theorem 4 in [4]. The only if part follows from the Pohozaev identity (see prop. 1 in [4]). \square

Unfortunately, by proposition 2, the energy (rest mass) of solutions $(0, \varphi)$ of the electrostatic equation

$$\mathcal{E}(0, \varphi) = -\frac{1}{3} \int |\nabla \varphi|^2 dx = \int W(-\varphi^2) dx$$

is negative; they are not physically acceptable for our program.

Thus, by Theorem 5, a necessary condition in order the system (43, 44) does not possess negative energy solutions, is the following:

- **(W⁺)**

$$W(s) \geq 0 \tag{53}$$

More exactly, we have the following result:

Proposition 6. *All the finite energy solutions of the system (43), (44) possess non-negative energy if and only if assumption W^+ is satisfied. Moreover if W^+ is satisfied, the bond energy (42) of any finite energy solution (\mathbf{A}, φ) of (43), (44) is not positive.*

Proof. The only if part has already been proved. The if part follows immediately from Prop. 2.

By (42) the bond energy is

$$\mathcal{E}_b = - \int \left(\rho(\sigma)\varphi + \frac{1}{2}W(\sigma) \right) dx,$$

$$\sigma = |\mathbf{A}|^2 - \varphi^2, \quad \rho(\sigma) = W'(\sigma)\varphi.$$

Now, by (53), we have

$$\int W(\sigma) dx \geq 0.$$

Moreover, by (44) we easily derive

$$\int \rho(\sigma)\varphi dx = \int W'(\sigma)\varphi^2 dx = \int |\nabla \varphi|^2 dx \geq 0.$$

Then we conclude that \mathcal{E}_b is not positive. \square

In order to get solutions of the magnetostatic equation (50) we need to make some other technical assumptions:

- (W3) There are constants M_1 and M_2 such that

$$W(s) \geq M_1 |s|^{p/2}; \quad 2 < p < 6 \quad \text{for } |s| \geq 1$$

$$W(s) \geq M_2 |s|^{q/2}; \quad q > 6 \quad \text{for } |s| \leq 1.$$

- (W4) $W \in C^2$ and

$$W''(s) > 0 \quad \text{for } s \neq 0.$$

Clearly assumption (W3) implies (W⁺). Moreover, given $\varepsilon_1 \varepsilon_2 > 0$, it is possible to choose suitable constants in (W3) and (W2) such that (W1) holds.

The following result holds.

Theorem 7. *If (W2), (W3) and (W4) hold, then eq. (50) has a nontrivial, finite energy solution. This solution has radial symmetry, namely*

$$\mathbf{A}(x) = g^{-1} \mathbf{A}(gx) \quad \forall g \in O(3)$$

where $O(3)$ is the orthogonal group in \mathbf{R}^3 .

3.3. Solitary waves

A solitary wave is a solution of a field equation whose energy travels as a localized packet. Since our equations are invariant for the action of the Poincaré group, given a static solution

$$(\mathbf{A}(x), \varphi(x))$$

it is possible to produce a solitary wave, moving with velocity $\mathbf{v} = (v, 0, 0)$ with $|v| < 1$, just making a Lorentz transformation

$$\begin{bmatrix} \mathbf{A}_{\mathbf{v}}(x, t) \\ \varphi_{\mathbf{v}}(x, t) \end{bmatrix} = \begin{bmatrix} \mathbf{A}'(x'(x, t)) \\ \varphi'(x'(x, t)) \end{bmatrix} \quad (54)$$

where

$$x' = \begin{bmatrix} \frac{x_1 - vt}{\sqrt{1-v^2}} \\ x_2 \\ x_3 \end{bmatrix}; \quad \mathbf{A}' = \begin{bmatrix} \frac{A_1 + v\varphi}{\sqrt{1-v^2}} \\ A_2 \\ A_3 \end{bmatrix}; \quad \varphi' = \frac{\varphi + vA_1}{\sqrt{1-v^2}}.$$

Solitary waves have a particle-like behavior. In particular, if (\mathbf{A}, φ) is a static solution with radial symmetry, the region filled with matter

$$\Omega = \left\{ x \in \mathbf{R}^3 : \left| |\mathbf{A}(x)|^2 - \varphi(x)^2 \right| \geq 1 \right\}$$

is a ball centered at the origin. Applying the above Lorentz transformation,

$$\Omega_t = \left\{ x \in \mathbf{R}^3 : \left| |\mathbf{A}_{\mathbf{v}}(x, t)|^2 - \varphi_{\mathbf{v}}(x, t)^2 \right| \geq 1 \right\}$$

becomes a rotation ellipsoid moving in direction x_1 with velocity \mathbf{v} and having the shortest axis of length $R\sqrt{1-v^2}$ (where R is the radius of Ω). If we let the nonlinear term

$$W(t) = W_{\varepsilon}(t) := \frac{1}{\varepsilon^2} W_1(t)$$

depend on a small parameter ε , then the radius of Ω becomes εR . Letting $\varepsilon \rightarrow 0$, the particles approach a pointwise behavior.

Moreover, the solitary waves obtained by this method present the following features:

- It can be directly verified that the momentum $\mathbf{P}(\mathbf{A}_{\mathbf{v}}, \varphi_{\mathbf{v}})$ in (40) of the solitary wave (54) is proportional to the velocity \mathbf{v} ,

$$\mathbf{P}(\mathbf{A}_{\mathbf{v}}, \varphi_{\mathbf{v}}) = m\mathbf{v}, \quad m > 0.$$

So the constant m defines the inertial mass of (54). Moreover, if we calculate the energy $\mathcal{E}(\mathbf{A}_{\mathbf{v}}, \varphi_{\mathbf{v}})$ (39) of (54), it can be seen that

$$m = \mathcal{E}(\mathbf{A}_{\mathbf{v}}, \varphi_{\mathbf{v}})$$

(Einstein equation; in our model we have set $c = 1$).

- The mass increases with velocity

$$m = \frac{m_0}{\sqrt{1 - v^2}}$$

where

$$m_0 = \mathcal{E}(\mathbf{A}, \varphi) = \frac{1}{3} \int (|\nabla \times \mathbf{A}|^2 - |\nabla \varphi|^2) dx = \int W (|\mathbf{A}|^2 - \varphi^2) dx \quad (55)$$

is the rest mass.

- If we do not take into account the effect of the magnetic moment μ (see proposition 3 and remark 4) the barycenter $\mathbf{q} = \mathbf{q}(\mathbf{t})$ of the solitary wave (54) in a given exterior field \mathbf{E}, \mathbf{H} satisfies the equation

$$\frac{d}{dt} \frac{m_0}{\sqrt{1 - |\dot{\mathbf{q}}|^2}} \dot{\mathbf{q}} = e(\mathbf{E} + \mathbf{v} \times \mathbf{H})$$

where e is the charge (see (41)) of the solitary wave $(\mathbf{A}_{\mathbf{v}}, \varphi_{\mathbf{v}})$,

$$e = \int W' (|\mathbf{A}_{\mathbf{v}}|^2 - \varphi_{\mathbf{v}}^2) \varphi_{\mathbf{v}} dx.$$

Concluding, our solitary waves behave as relativistic particles except that they have space extension. These facts are a consequence of the invariance of the Lagrangian density with respect to the Poincaré group. For more details we refer to [3].

4. The existence result

First we write equation (50) in a slightly more general form.

Let $f : \mathbf{R}^3 \rightarrow \mathbf{R}$ be a C^2 function satisfying the assumptions

$$f(0) = 0 \text{ and } f \text{ strictly convex.} \quad (56)$$

There are positive constants c_1, c_2, p, q with $2 < p < 6 < q$ such that

$$c_1 |\xi|^p \leq f(\xi) \text{ for } |\xi| \geq 1 \quad (57)$$

$$c_1 |\xi|^q \leq f(\xi) \text{ for } |\xi| \leq 1 \quad (58)$$

$$|f'(\xi)| \leq c_2 |\xi|^{p-1} \text{ for } |\xi| \geq 1 \quad (59)$$

$$|f'(\xi)| \leq c_2 |\xi|^{q-1} \text{ for } |\xi| \leq 1. \quad (60)$$

We are interested in finding nontrivial, finite energy, weak solutions $\mathbf{A} : \mathbf{R}^3 \rightarrow \mathbf{R}^3$ of the equation

$$\nabla \times \nabla \times \mathbf{A} = f'(\mathbf{A}) \quad (61)$$

where f' denotes the gradient of f .

\mathbf{A} weak solution of (61) means that both \mathbf{A} and $f'(\mathbf{A})$ are in L^1_{loc} and that for all $\varphi \in C_0^\infty(\mathbf{R}^3, \mathbf{R}^3)$

$$\int (\mathbf{A} \mid \nabla \times (\nabla \times \varphi)) dx = \int (f'(\mathbf{A}) \mid \varphi) dx$$

where $(\cdot \mid \cdot)$ denotes the Euclidean inner product in \mathbf{R}^3 .

Theorem 7 clearly follows from the following result.

Theorem 8. *If f satisfies assumptions (56), (57), (58), (59) and (60), equation (61) has at least a nontrivial weak solution having finite and positive energy. Moreover this solution has radial symmetry, namely*

$$\mathbf{A}(x) = g^{-1} \mathbf{A}(gx) \text{ for all } g \in O(3).$$

First we give an heuristic idea of the proof of Theorem 8.

By the Hodge decomposition theorem, the vector field $\mathbf{A} : \mathbf{R}^3 \rightarrow \mathbf{R}^3$ in (61) can be splitted as

$$\mathbf{A} = u + v = u + \nabla w \quad (62)$$

where $u : \mathbf{R}^3 \rightarrow \mathbf{R}^3$ is a divergence free vector field ($\nabla \cdot u = 0$) and $v : \mathbf{R}^3 \rightarrow \mathbf{R}^3$ is a potential vector field, $v = \nabla w$ (w scalar field).

Since f is strictly convex, for every u with $\nabla \cdot u = 0$, we can find a scalar field w_0 which minimizes the functional

$$w \mapsto \int f(u + \nabla w).$$

Set $w_0 = \Phi(u)$. Replacing (62) in (2) with $w = \Phi(u)$, we get a new functional

$$J(u) := \mathcal{E}(u, \Phi(u)) = \int \left(\frac{1}{2} |\nabla u|^2 - f(u + \nabla \Phi(u)) \right) dx$$

which depends only on u . This functional has the mountain pass geometry. Then, we expect the existence of a nontrivial critical point u_0 . Now, if J and the map $u \rightarrow \Phi(u)$ were sufficiently smooth in suitable function spaces, the field

$$\mathbf{A} = u_0 + \nabla [\Phi(u_0)]$$

would solve equation (61). However, the lack of smoothness does not allow to carry out a rigorous simple proof directly. A complete proof of Theorem 8 is contained in [1]; here we indicate only the main steps of the proof.

4.1. The functional setting

In order to consider the Hodge decomposition (62) of \mathbf{A} , we introduce the functional setting for the two components u and v .

Let $\mathcal{D}(\mathbf{R}^3, \mathbf{R}^3)$ ($\mathcal{D}(\mathbf{R}^3, \mathbf{R})$) be the completion of $C_0^\infty(\mathbf{R}^3, \mathbf{R}^3)$ ($C_0^\infty(\mathbf{R}^3, \mathbf{R})$) with respect to the norm

$$\|u\|_{\mathcal{D}} = \left(\int_{\mathbf{R}^3} |\nabla u|^2 dx \right)^{\frac{1}{2}}.$$

Now (59), (60) with assumptions (57) and (58) imply that

$$c_1 |\xi|^p \leq f(\xi) \leq c_3 |\xi|^p \text{ for } |\xi| \geq 1 \quad (63)$$

$$c_1 |\xi|^q \leq f(\xi) \leq c_3 |\xi|^q \text{ for } |\xi| \leq 1. \quad (64)$$

So $f(\xi) \simeq |\xi|^p$ for $|\xi| \geq 1$ and $f(\xi) \simeq |\xi|^q$ for $|\xi| \leq 1$ and the choice of the function space for w is related to these growth properties of f . Consider first the space $L^p + L^q$ made up by the vector fields $v : \mathbf{R}^3 \rightarrow \mathbf{R}^3$ such that

$$v = v_1 + v_2, \text{ with } v_1 \in L^p, v_2 \in L^q.$$

$L^p + L^q$ is a Banach space with the norm

$$\|v\|_{L^p+L^q} = \inf \{ \|v_1\|_{L^p} + \|v_2\|_{L^q} : v_1 + v_2 = v \}.$$

It is well known that (see e. g. [5])

$$L^p + L^q = \left(L^{p'} \cap L^{q'} \right)'.$$

Moreover it can be shown that our assumptions imply that

$$f' \text{ is a bounded map from } L^p + L^q = \left(L^{p'} \cap L^{q'} \right)' \text{ into } L^{p'} \cap L^{q'}. \quad (65)$$

Now let $\mathcal{D}^{p,q}(\mathbf{R}^3, \mathbf{R})$ be the completion of $C_0^\infty(\mathbf{R}^3, \mathbf{R})$ with respect to the norm

$$\|w\|_{\mathcal{D}^{p,q}} = \|\nabla w\|_{L^p+L^q}.$$

The energy functional exhibits a lack of compactness due to its invariance under the space-translations. To overcome this difficulty we take u and the scalar field w in (62) belonging to suitable subspaces of $\mathcal{D}(\mathbf{R}^3, \mathbf{R}^3)$ and $\mathcal{D}^{p,q}(\mathbf{R}^3, \mathbf{R})$ respectively.

Let T_g, T'_g be the actions of the orthogonal group $O(3)$ on the fields $u : \mathbf{R}^3 \rightarrow \mathbf{R}^3$ and $w : \mathbf{R}^3 \rightarrow \mathbf{R}$ defined respectively as follows:

for all $g \in O(3)$ and $x \in \mathbf{R}^3$,

$$T_g u(x) = g^{-1} u(gx)$$

$$T'_g w(x) = w(gx).$$

Moreover, let F and F' be the sets of the fixed points for the actions T_g and T'_g respectively, namely

$$\begin{aligned} F &= \{u : \mathbf{R}^3 \rightarrow \mathbf{R}^3 : T_g u = u \text{ for all } g \in O(3)\} \\ F' &= \{w : \mathbf{R}^3 \rightarrow \mathbf{R} : T'_g w = w \text{ for all } g \in O(3)\}. \end{aligned}$$

And finally we set

$$\begin{aligned} \mathcal{V} &= \{u \in \mathcal{D}(\mathbf{R}^3, \mathbf{R}^3) \cap F : \nabla \cdot u = 0\} \\ \mathcal{W} &= \mathcal{D}^{p,q}(\mathbf{R}^3, \mathbf{R}) \cap F'. \end{aligned}$$

It can be shown that for all $g \in O(3)$, $u : \mathbf{R}^3 \rightarrow \mathbf{R}^3$ and $w : \mathbf{R}^3 \rightarrow \mathbf{R}$

$$\begin{aligned} T'_g(\nabla \cdot u) &= \nabla \cdot (T_g u) \\ \nabla(T'_g w) &= T_g(\nabla w) \end{aligned}$$

where $\nabla \cdot$ denotes the divergence operator.

So

$$(u \in F \text{ and } w \in F') \implies (u + \nabla w \in F). \quad (66)$$

The following compactness result can be proved by adapting to our case a well known radial lemma ([4]).

Lemma 9. *The space \mathcal{V} is compactly embedded into $L^p + L^q$.*

4.2. Sketch of the proof of Theorem 8

Since $\mathcal{V} \subset L^p + L^q$, we have that

$$\forall u \in \mathcal{V}, \forall w \in \mathcal{W} : u + \nabla w \in L^p + L^q$$

Then, by the growth properties of f , for any $u \in \mathcal{V}$ the functional

$$w \in \mathcal{W} \mapsto F(u, w) = \int f(u(x) + \nabla w(x)) dx$$

is well defined.

Using the strict convexity f , it can be shown that

Proposition 10. *For any $u \in \mathcal{V}$, there exists a unique $w \in \mathcal{W}$ which minimizes the functional $F(u, \cdot)$.*

Now we can consider the map

$$\Phi : \mathcal{V} \rightarrow \mathcal{W} \quad (67)$$

such that for any $u \in \mathcal{V}$, $\Phi(u)$ is the minimizer of $F(u, \cdot)$.

Using the compactness lemma 9 and the convexity of f it is possible to prove the following

Proposition 11. *The functional $u \rightarrow F(u, \Phi(u)) = \int f(u + \nabla \Phi(u)) dx$ is weakly continuous on \mathcal{V} .*

Now consider the functional

$$J(u) := \mathcal{E}(u, \Phi(u)) = \frac{1}{2} \int |\nabla u|^2 dx - F(u, \Phi(u)), \quad u \in \mathcal{V}.$$

We do not know if the map Φ is C^1 , and to overcome this lack of smoothness we argue as follows. Let $u_0 \in \mathcal{V}$, $u_0 \neq 0$. Then

$$u_0 + \nabla\Phi(u_0) \neq 0.$$

So $t_0 := \frac{1}{2}F(u_0, \Phi(u_0)) > 0$.

Consider the functional

$$J_\beta(u) = \frac{1}{2} \int |\nabla u|^2 dx - \beta(F(u, \Phi(u))), \quad u \in \mathcal{V}$$

where $\beta : \mathbf{R} \rightarrow \mathbf{R}$ is a function such that

- $\beta(t) \geq 0$; $\beta(t) = 0$ for $t \leq 0$
- $\beta'(t) \geq 0$
- β is bounded
- $\beta(F(u_0, \Phi(u_0))) \geq 1 + \frac{1}{2} \int |\nabla u_0|^2 dx$.

The functional J_β is bounded from below and coercive. Moreover, by Proposition 11, $\beta(F(u, \Phi(u)))$ is weakly continuous on \mathcal{V} . Then, since $J_\beta(u_0) \leq -1$, we get the existence of a minimizer u in \mathcal{V} such that $J_\beta(u) \leq J_\beta(u_0) \leq -1$.

Now, using again the convexity of f , the following proposition can be proved.

Proposition 12. *Let u be a minimizer of J_β in \mathcal{V} . Then there is $\mu > 0$ such that*

$$\int (\nabla u \mid \nabla h) dx - \mu \int (f'(u + \nabla\Phi(u)) \mid h) dx = 0 \text{ for all } h \in \mathcal{V} \quad (68)$$

where $(\cdot \mid \cdot)$ denotes the Euclidean inner product.

Observe that by (65) $f'(u + \nabla\Phi(u))$ belongs to $L^{p'} \cap L^{q'}$, so (68) makes sense. Now, if u is a minimizer of J_β , the rescaled function

$$u_\lambda(x) = u(\lambda x), \quad \lambda = \frac{1}{\sqrt{\mu}}$$

satisfies the equation

$$\int (\nabla u_\lambda \mid \nabla h) dx - \int (f'(u_\lambda + \nabla\Phi(u_\lambda)) \mid h) dx = 0 \text{ for all } h \in \mathcal{V}.$$

So, since $\nabla \cdot u = 0$ and $\nabla \cdot h = 0$, we have

$$\int (\nabla \times u_\lambda \mid \nabla \times h) dx - \int (f'(u_\lambda + \nabla\Phi(u_\lambda)) \mid h) dx = 0 \text{ for all } h \in \mathcal{V}. \quad (69)$$

Set

$$\mathbf{A} = u_\lambda + \nabla\Phi(u_\lambda).$$

Since $u_\lambda \neq 0$ and $\nabla \cdot u_\lambda = 0$, \mathbf{A} is not trivial. Moreover $f'(\mathbf{A}) \in F$, because $\mathbf{A} \in F$. Then, using this symmetry property, we can deduce from (69) that \mathbf{A} solves (61), namely for all $\varphi \in C_0^\infty(\mathbf{R}^3, \mathbf{R}^3)$ we have

$$\int (\mathbf{A} | \nabla \times (\nabla \times \varphi)) dx - \int (f'(\mathbf{A}) | \varphi) dx = 0 \quad (70)$$

□

References

- [1] BENCI V., FORTUNATO D., *Towards a unified field theory for classical electrodynamics*, Arch. Rat. Mech. Anal. **173** (2004), 379-414.
- [2] BENCI V., FORTUNATO D., *Solitary waves of the nonlinear Klein-Gordon field equation coupled with the Maxwell equations*, Rev. Math. Phys. **14** (2002), 409-420.
- [3] BENCI V. FORTUNATO D., *Solitary waves of the Semilinear Maxwell equations and their dynamical properties*, in preparation.
- [4] BERESTYCKI H., LIONS P.L., *Nonlinear Scalar Field Equations, I - Existence of a Ground State*, Arch. Rat. Mech. Anal., **82** (4) (1983), 313-345.
- [5] BERG J., LÖFSTRÖM J., *Interpolation Spaces*, Springer-Verlag, Berlin, Heidelberg, New York, (1976).
- [6] BORN M., *Théorie non-linéaire du champ électromagnétique*, Ann. Inst. H. Poincaré, 1937.
- [7] BORN M., INFELD L., *Foundations of the new field theory*, Nature, **132** (1933), 1004.
- [8] BORN M., INFELD L., *Foundations of the new field theory*, Proc. R. Soc. Lon. A, **144** (1934), 425-451.
- [9] GELFAND I.M., FOMIN S.V., *Calculus of Variations*, Prentice-Hall, Englewood Cliffs, N.J. (1963).
- [10] JACKSON J.D., *Classical electrodynamics*, John Wiley & Sons., New York, London, (1962).
- [11] LANDAU L., LIFCHITZ E., *Théorie des Champs*, Editions Mir, Moscou, (1970).
- [12] THIRRING W., *Classical Mathematical Physics*, Springer, New York, Vienna, (1997).
- [13] YANG Y., *Classical solutions in the Born-Infeld theory*, Proc. R. Soc. Lon. A (2000), **456**, 615-640.
- [14] YANG Y., *Solitons in Field Theory and and Nonlinear Analysis*, Springer, New York, Berlin, 2000.

Vieri Benci

Dipartimento di Matematica Applicata "U. Dini", Università degli Studi di Pisa, Via Bonanno 25/b, 56126 Pisa, Italy

e-mail: benci@dma.unipi.it

Donato Fortunato

Dipartimento di Matematica, Università di Bari, Via Orabona 4, 70125 Bari, Italy

e-mail: fortunat@dm.uniba.it

Existence of Solutions for the Nonlinear Schrödinger Equation with $V(\infty) = 0$

Vieri Benci, Carlo R. Grisanti and Anna Maria Micheletti

Dedicated to Professor Djairo de Figueiredo

Abstract. We study the existence of a solution of the problem

$$\begin{cases} -\Delta u + V(x)u = f'(u) & x \in \mathbb{R}^N, \\ u(x) > 0, \end{cases}$$

under the assumption that

$$\lim_{|x| \rightarrow \infty} V(x) = 0$$

where $V > 0$ and there is no ground state solution.

Mathematics Subject Classification (2000). 35Q55, 35J60.

Keywords. Variational methods, minimax methods, Orlicz spaces.

1. Introduction

We will study the existence of finite energy solutions of the problem

$$\begin{cases} -\Delta u + V(x)u = f'(u) & x \in \mathbb{R}^N, \quad N \geq 3 \\ F_V(u) < \infty \\ u(x) > 0, \end{cases} \quad (1.1)$$

where the energy is defined by

$$F_V(u) = \frac{1}{2} \int_{\mathbb{R}^N} |\nabla u|^2 dx + \frac{1}{2} \int_{\mathbb{R}^N} V u^2 dx - \int_{\mathbb{R}^N} f(u) dx, \quad (1.2)$$

and f is a function which satisfies suitable conditions.

The case $V = 0$ and $f(s) = |s|^p$ has been studied by Berestycki and Lions [9] who proved that the problem has no solutions. They also proved that if the problem has a solution then the function f must have a supercritical growth near

the origin and subcritical at infinity. To this aim, in [7] the authors considered a function f which satisfies the following requirements:

$$\text{there exists } \mu > 2 \text{ such that } 0 < \mu f(s) \leq f'(s)s < f''(s)s^2 \quad \forall s \neq 0 \quad (1.3)$$

there exist positive numbers c_0, c_2, p, q with $2 < p < 2^* < q$ such that

$$\begin{cases} c_0|s|^p \leq f(s) & \text{for } |s| \geq 1 \\ c_0|s|^q \leq f(s) & \text{for } |s| \leq 1 \end{cases} \quad (1.4)$$

$$\begin{cases} |f''(s)| \leq c_2|s|^{p-2} & \text{for } |s| \geq 1 \\ |f''(s)| \leq c_2|s|^{q-2} & \text{for } |s| \leq 1 \end{cases} \quad (1.5)$$

where $2^* = \frac{2N}{N-2}$.

We assume $V \in L^{N/2}(\mathbb{R}^N)$.

In [7] we showed that, if $V \geq 0$ and $V > 0$ on a set of positive measure, the problem (1.1) has no ground state solution, i.e., there is no solution u of (1.1) which minimizes the functional F_V on the Nehari manifold \mathcal{N}^V ,

$$\mathcal{N}^V = \left\{ u \in \mathcal{D}^{1,2}(\mathbb{R}^N) \setminus \{0\} : \int_{\mathbb{R}^N} |\nabla u|^2 + Vu^2 - f'(u)u = 0 \right\}. \quad (1.6)$$

On the contrary, if $V \equiv 0$, the problem (1.1) has ground state solutions (cfr. [8], [9]), and we call m the level of the functional F_0 associated with such solutions,

$$m = \inf_{u \in \mathcal{N}^0} F_0(u). \quad (1.7)$$

We shall prove the following existence result:

Theorem 1.1. *Assume that the critical value (ground level) m of the functional F_0 is isolated. Then there exists ϵ_0 such that, if $\|V\|_{L^{N/2}(\mathbb{R}^N)} < \epsilon_0$, the problem (1.1) has a solution.*

We want to mention very recent results related to this problem.

Benci and Micheletti in [8] study the same problem with $V = 0$ but in an exterior domain Ω . They prove that there is no ground state solution; however, the problem has a solution if $\mathbb{R}^N \setminus \Omega \subset B_\epsilon = \{x \in \mathbb{R}^N : |x| < \epsilon\}$ for ϵ small enough. Ambrosetti, Felli and Malchiodi in [2] consider the problem $-\epsilon^2 \Delta v + V(x)v = K(x)v^p$ with potential $V(x) \sim |x|^{-\alpha}$ and $K(x) \sim |x|^{-\beta}$ where $0 < \alpha < 2$ and $\beta > 0$. The existence of a ground state $v \in H^1(\mathbb{R}^N)$ is proved for subcritical p depending on α and β .

The plan of the paper is the following:

- in section 2 we recall some results about the smoothness of F_V and the behaviour of its Palais–Smale sequences;
- in section 3 we investigate the topology of the sublevels of our functional F_V and by the estimates of the levels where the Palais–Smale condition holds, we obtain our main result.

2. Preliminary results and notations

We will use the following notations:

- $v_y(x) = v(x + y)$
- $B_R(z) = \{x \in \mathbb{R}^N : |x - z| < R\}$
- $\Gamma_v = \{x \in \mathbb{R}^N : |v(x)| > 1\}$
- $|A|$ = Lebesgue measure of the subset $A \subset \mathbb{R}^N$
- $\mathcal{D}^{1,2}(\mathbb{R}^N) =$ completion of $C_0^\infty(\mathbb{R}^N)$ with respect to the norm

$$\|u\|_{\mathcal{D}^{1,2}(\mathbb{R}^N)} = \left(\int_{\mathbb{R}^N} |\nabla u|^2 dx \right)^{\frac{1}{2}}.$$

In dealing with our functional F_V , it is convenient to consider the function space related to the growth properties of the function f and to recall some results obtained in [5], [8] and [7].

Given $p \neq q$, we consider the space $L^p + L^q$ made up of the functions $v : \mathbb{R}^N \mapsto \mathbb{R}$ such that

$$v = v_1 + v_2 \quad \text{with } v_1 \in L^p(\mathbb{R}^N), v_2 \in L^q(\mathbb{R}^N).$$

$L^p + L^q$ is a Banach space with the norm

$$\|v\|_{L^p+L^q} = \inf \{ \|v_1\|_{L^p} + \|v_2\|_{L^q} : v_1 + v_2 = v \}.$$

It is well known that (see [11]) $L^p + L^q$ coincides with the dual of $L^{p'} \cap L^{q'}$. Then

$$L^p + L^q = \left(L^{p'} \cap L^{q'} \right)' \quad \text{with } p' = \frac{p}{p-1}, q' = \frac{q}{q-1}. \quad (2.1)$$

Actually $L^p + L^q$ is an Orlicz space with N -function (cf. e.g. [11])

$$A(u) = \max\{|u|^p, |u|^q\}$$

First we recall some inequalities relative to the space $L^p + L^q$ proved in [6] (see also [5]).

Lemma 2.1. (i) *If $v \in L^p + L^q$, the following inequalities hold:*

$$\begin{aligned} & \max \left[\|v\|_{L^q(\mathbb{R}^N - \Gamma_v)} - 1, \frac{1}{1 + |\Gamma_v|^{\frac{1}{\tau}}} \|v\|_{L^p(\Gamma_v)} \right] \\ & \leq \|v\|_{L^p+L^q} \\ & \leq \max \left[\|v\|_{L^q(\mathbb{R}^N - \Gamma_v)}, \|v\|_{L^p(\Gamma_v)} \right] \end{aligned}$$

when $\tau = \frac{pq}{q-p}$.

(ii) *Let $\{v_n\} \subset L^p + L^q$ and set $\Gamma_n = \{x \in \Omega : |v_n(x)| > 1\}$. Then $\{v_n\}$ is bounded in $L^p + L^q$ if and only if the sequences $\{\|v_n\|_{L^q(\mathbb{R}^N - \Gamma_n)} + \|v_n\|_{L^p(\Gamma_n)}\}$ and $\{|\Gamma_n|\}$ are bounded.*

(iii) *f' is a bounded map from $L^p + L^q$ into $L^{p/p-1} \cap L^{q/q-1}$.*

Remark 2.2. By (i) of Lemma 2.1 we have $L^{2^*} \subset L^p + L^q$ when $2 < p < 2^* < q$. Then, by the Sobolev inequality, we get the continuous embedding

$$\mathcal{D}^{1,2}(\mathbb{R}^N) \subset L^p + L^q. \quad (2.2)$$

The regularity of the functional F_V and of the related Nehari manifold \mathcal{N}^V are contained in the following lemma which is proved in [7] and in [23].

Lemma 2.3.

- (i) F_V is of class C^2 .
- (ii) $\mathcal{N}^V(\mathbb{R}^N)$ is a C^1 manifold.
- (iii) For any given $u \in \mathcal{D}^{1,2} \setminus \{0\}$, there exists a unique real number $t_u^V > 0$ such that $ut_u^V \in \mathcal{N}^V$ and $F_V(t_u^V u)$ is the maximum for the function $t \mapsto F_V(tu)$, $t \geq 0$.
- (iv) The function $(V, u) \mapsto t(V, u) = t_u^V$ defined on the set $\left\{ V \in L^{\frac{N}{2}} : \|V\|_{\frac{N}{2}} < S \right\} \times \mathcal{D}^{1,2} \setminus \{0\}$ is of class C^1 and it holds

$$\langle t'_V(\bar{V}, \bar{u}), V \rangle = \frac{\bar{t}^3 \int_{\mathbb{R}^N} V \bar{u}^2 dx}{\int_{\mathbb{R}^N} f''(\bar{t}\bar{u})(\bar{t}\bar{u})^2 - f'(\bar{t}\bar{u})\bar{t}\bar{u} dx}$$

where $\bar{t} = t(\bar{V}, \bar{u}) = t_{\bar{u}}^{\bar{V}}$.

Here we recall a “splitting lemma” obtained in [8] and in [7], which is a variant of a well known result of Struwe (see [27]). This is an important tool to study the problems with lack of compactness.

Lemma 2.4 (Splitting Lemma). Let $\{u_n\} \subset \mathcal{N}^V$ be a sequence such that

$$\begin{aligned} F_V(u_n) &\rightarrow c \quad \text{as } n \rightarrow +\infty, \\ F'_V|_{\mathcal{N}^V}(u_n) &\rightarrow 0 \quad \text{in } (\mathcal{D}^{1,2}(\mathbb{R}^N))' \quad \text{as } n \rightarrow +\infty. \end{aligned}$$

Then there exist k sequences of points $\{y_n^j\}_{n \in \mathbb{N}}$ ($1 \leq j \leq k$) with $|y_n^j| \rightarrow +\infty$ as $n \rightarrow +\infty$, and $k+1$ sequences of functions $\{u_n^j\}_{n \in \mathbb{N}}$ ($0 \leq j \leq k$) such that, up to a subsequence,

- (i) $u_n(x) = u_n^0(x) + \sum_{j=1}^k u_n^j(x - y_n^j)$;
- (ii) $u_n^0(x) \rightarrow u^0(x)$ as $n \rightarrow +\infty$ in $\mathcal{D}^{1,2}(\mathbb{R}^N)$;
- (iii) $u_n^j(x) \rightarrow u^j(x)$ as $n \rightarrow +\infty$ in $\mathcal{D}^{1,2}(\mathbb{R}^N)$,

where u^0 is a solution of (1.1) and u^j ($1 \leq j \leq k$) is a solution of the same problem with $V = 0$. Furthermore, when $n \rightarrow +\infty$:

$$\|u_n\|_{\mathcal{D}^{1,2}(\mathbb{R}^N)}^2 \rightarrow \|u^0\|_{\mathcal{D}^{1,2}(\mathbb{R}^N)}^2 + \sum_{j=1}^k \|u^j\|_{\mathcal{D}^{1,2}(\mathbb{R}^N)}^2$$

and

$$F_V(u_n) \rightarrow F_V(u_0) + \sum_{j=1}^k F_0(u^j).$$

3. The main result

Lemma 3.1. *Let w be a solution to problem (1.1) with $V = 0$. Then the application $y \mapsto w_y = w(\cdot + y)$ is a continuous map from \mathbb{R}^N in $\mathcal{D}^{1,2}(\mathbb{R}^N)$.*

Proof. Let us fix $y_0 \in \mathbb{R}^n$ and let y_n be a sequence of numbers converging to zero. We set $w_n(x) = w_{y_n}(x) = w(x + y_n)$. Then

$$\begin{aligned} \int_{\mathbb{R}^N} |\nabla(w_{y_0} - w_{y_0+y_n})|^2 &= \int_{\mathbb{R}^N} |\nabla w_{y_0+y_n}|^2 + |\nabla w_{y_0}|^2 dx \\ &- 2 \int_{\mathbb{R}^N} \nabla w_{y_0+y_n} \cdot \nabla w_{y_0} dx = 2 \int_{\mathbb{R}^N} |\nabla w|^2 - 2 \int_{\mathbb{R}^n} \nabla w_n \cdot \nabla w dx. \end{aligned}$$

Since $\|\nabla w_n\|_2 = \|\nabla w\|_2$, the sequence w_n is bounded in $\mathcal{D}^{1,2}$, hence, up to a subsequence, (w_n) converges weakly in $\mathcal{D}^{1,2}$ towards a function v . If we choose an arbitrary bounded set $\omega \subset \mathbb{R}^N$, by the compact embedding theorem, $w_n \rightarrow v$ strongly in $L^2(\omega)$. But w_n converges strongly to w in $L^2(\mathbb{R}^n)$, hence $v = w$ and, by the weak convergence in $\mathcal{D}^{1,2}$:

$$\int_{\mathbb{R}^N} \nabla w_n \cdot \nabla w dx \rightarrow \int_{\mathbb{R}^N} |\nabla w|^2 dx.$$

Hence $w_{y_0+y_n}$ converges strongly to w_{y_0} in $\mathcal{D}^{1,2}$. □

Lemma 3.2. *For any fixed $V \in L^{N/2}$ it results $\lim_{|y| \rightarrow \infty} \int_{\mathbb{R}^N} V(x)w_y(x)^2 dx = 0$.*

Proof. Given $\epsilon > 0$ there exists $R > 0$ such that $\|V\|_{L^{N/2}(\mathbb{R}^N \setminus B_R)} \leq \frac{\epsilon}{2\|w\|_{2^*}^2}$, and if $|y| > R$, then $\int_{B_R(y)} |w(x)|^{2^*} dx \leq \frac{\epsilon}{2\|V\|_{N/2}}$. Hence, we have:

$$\begin{aligned} \int_{\mathbb{R}^N} V w_y^2 dx &= \int_{B_R} V w_y^2 dx + \int_{\mathbb{R}^N \setminus B_R} V w_y^2 dx \\ &\leq \|V\|_{L^{N/2}(B_R)} \|w_y\|_{L^{2^*}(B_R)}^2 + \|V\|_{L^{N/2}(\mathbb{R}^N \setminus B_R)} \|w_y\|_{L^{2^*}(\mathbb{R}^N)}^2 \leq \epsilon. \end{aligned}$$

□

Lemma 3.3. (i) *For any given $\rho > 0$ there exists $t_2 \in \mathbb{R}$ such that $t_{w_y}^V \leq t_2$ for every $y \in \mathbb{R}^N$ and for every $V \in L^{\frac{N}{2}}$ such that $\|V\|_{\frac{N}{2}} < \rho$.*

- (ii) For every $V \in L^{\frac{N}{2}}$ there exist $R(V) > 0$ and $t_1(V) > 0$ such that $t_1(V) \leq t_{w_y}^V$ for every $y \in \mathbb{R}^N$ with $|y| > R(V)$.
- (iii) For every $V \in L^{\frac{N}{2}}$ it holds $\lim_{|y| \rightarrow \infty} t_{w_y}^V = 1$.
- (iv) It holds

$$\lim_{\|V\|_{N/2} \rightarrow 0} \sup_{y \in \mathbb{R}^N} |t_{w_y}^V - 1| = 0.$$

Proof. (i) Let us set $g_u^V(t) = F_V(tu)$. Then, by (1.4), for every $t \geq 1$ and for every V satisfying the above hypothesis, we have:

$$\begin{aligned} g_{w_y}^V(t) &= g_w^0(t) + t^2 \int_{\mathbb{R}^N} V w_y^2 dx \leq \frac{t^2}{2} \|w\|_{\mathcal{D}^{1,2}}^2 - c_0 t^p \int_{\{|w| \geq \frac{1}{t}\}} |w|^p dx + t^2 \int_{\mathbb{R}^N} V w_y^2 dx \\ &\leq t^2 \left(\frac{1}{2} \|w\|_{\mathcal{D}^{1,2}}^2 + \|V\|_{\frac{N}{2}} \|w\|_{2^*}^2 \right) - c_0 t^p \int_{\{|w| \geq \frac{1}{t}\}} |w|^p dx \\ &\leq t^2 \left(\frac{1}{2} \|w\|_{\mathcal{D}^{1,2}}^2 + \rho \|w\|_{2^*}^2 - c_0 t^{p-2} \int_{\{|w| \geq 1\}} |w|^p dx \right). \end{aligned}$$

Hence, there exists $t_2 > 0$ such that $g_{w_y}^V(t) < 0$, for every $t > t_2$, for every $y \in \mathbb{R}^N$. It follows that $t_{w_y}^V \leq t_2$.

- (ii) First we observe that

$$\left| g_{w_y}^V(t) - g_w^0(t) \right| \leq t^2 \int_{\mathbb{R}^N} |V(x)| w_y^2(x) dx.$$

Let us suppose, by contradiction, that there exists a sequence y_n such that $|y_n| \rightarrow \infty$ and $t_{w_{y_n}} \rightarrow 0$. Let t^* be the maximum point for g_w^0 ; then, by Lemma 3.2, we have

$$\begin{aligned} 0 < g_w^0(t^*) &= \lim_{n \rightarrow \infty} \left(g_w^0(t^*) + (t^*)^2 \int_{\mathbb{R}^N} |V(x)| w_{y_n}^2(x) dx \right) \\ &= \lim_{n \rightarrow \infty} g_{w_{y_n}}^V(t^*) \leq \lim_{n \rightarrow \infty} g_{w_{y_n}}^V(t_{w_{y_n}}^V) = 0, \end{aligned}$$

and this completes the proof.

- (iii) Let us recall that $t_{w_y}^0 = t_w^0 = 1$. Hence:

$$|t_{w_y}^V - 1| = |t_{w_y}^V - t_{w_y}^0| = |\langle t_V'(\theta V, w_y), V \rangle| = \frac{\bar{t}^3 \left| \int V w_y^2 \right|}{\int f''(\bar{t}w)(\bar{t}w)^2 - f'(\bar{t}w)(\bar{t}w)} \quad (3.1)$$

where $0 < \theta < 1$ and $\bar{t} = t_{w_y}^{\theta V}$. By (i) and (ii) the number \bar{t} is bounded between t_1 and t_2 , uniformly as $|y| \rightarrow \infty$, then, since $\lim_{|y| \rightarrow \infty} \int V w_y^2 = 0$, we obtain the claim.

(iv) We observe that the function $t \mapsto \int_{\mathbb{R}^N} f''(tw)(tw)^2 - f'(tw)(tw) dx$ is continuous and strictly positive for $t > 0$. Hence, by equation (3.1), we obtain:

$$|t_{w_y}^V - 1| \leq \frac{(t_2)^3}{\min_{t \in [t_1, t_2]} \int_{\mathbb{R}^N} f''(tw)(tw)^2 - f'(tw)(tw)} \|w\|_{2^*}^2 \|V\|_{N/2}$$

which completes the proof. \square

We define $\beta(u) : \mathcal{D}^{1,2}(\mathbb{R}^N) \longrightarrow \mathbb{R}^N$ in the following way:

$$\beta(u) = \int_{\mathbb{R}^N} |\nabla u|^2 \frac{x}{|x|} dx.$$

We observe that β is continuous with respect to the strong topology of $\mathcal{D}^{1,2}(\mathbb{R}^N)$. In fact:

$$\begin{aligned} |\beta(u_0 + u) - \beta(u_0)| &= \left| \int_{\mathbb{R}^N} (|\nabla(u_0 + u)|^2 - |\nabla u_0|^2) \frac{x}{|x|} dx \right| \leq \\ &\leq \int_{\mathbb{R}^N} |\nabla u|^2 + 2 \left| \int_{\mathbb{R}^N} \nabla u \cdot \nabla u_0 \right| \end{aligned}$$

and the last quantity goes to zero as $\|u\|_{\mathcal{D}^{1,2}} \rightarrow 0$.

Definition 3.4. We set

$$\mathcal{B}_0 = \{u \in \mathcal{D}^{1,2}(\mathbb{R}^N) : \beta(u) = 0\}.$$

and, given $V \in L^{N/2}(\mathbb{R}^N)$,

$$\gamma^V = \inf_{\mathcal{N}^V \cap \mathcal{B}_0} F_V.$$

Lemma 3.5. Given $V \in L^{N/2}(\mathbb{R}^N)$ with $V \geq 0$ it results $\gamma^V > m$.

Proof. It is trivial that $\gamma^V \geq m$. By contradiction we assume that $\gamma^V = m$. Then there exists a minimizing sequence (u_n) for the functional F_V on the manifold \mathcal{N}^V such that $(u_n) \subset \mathcal{B}_0$. By the Ekeland variational principle we can assume that (u_n) is a Palais–Smale sequence for the restriction of F_V to the Nehari manifold \mathcal{N}^V . By Lemma 2.4 (splitting lemma), there exists a sequence $(y_n) \subset \mathbb{R}^N$ with $|y_n| \rightarrow +\infty$ and a ground state solution $w \in \mathcal{D}^{1,2}(\mathbb{R}^N)$ of the equation $\Delta w = f'(w)$ such that

$$u_n(x) = w(x - y_n) + v_n(x) \tag{3.2}$$

where $v_n \rightarrow 0$ in $\mathcal{D}^{1,2}$. We set $w(x - y_n) = w_n$. Since, up to a subsequence, $w_n \rightharpoonup 0$ weakly in $\mathcal{D}^{1,2}(\mathbb{R}^N)$, we have

$$\begin{aligned} |\beta(u_n) - \beta(w_n)| &= \left| \int_{\mathbb{R}^N} \left(|\nabla(w_n + v_n)|^2 - |\nabla w_n|^2 \right) \frac{x}{|x|} dx \right| \\ &\leq \int_{\mathbb{R}^N} |\nabla v_n|^2 dx + 2 \left| \int_{\mathbb{R}^N} \nabla v_n \cdot \nabla w_n dx \right| \rightarrow 0 \text{ as } n \rightarrow \infty. \end{aligned} \quad (3.3)$$

Now we calculate $\beta(w_n)$:

$$\beta(w_n) = \int_{\mathbb{R}^N} |\nabla w(x - y_n)|^2 \frac{x}{|x|} dx = \int_{\mathbb{R}^N} |\nabla w(z)|^2 \frac{z + y_n}{|z + y_n|} dz. \quad (3.4)$$

By (3.4) and the Lebesgue dominated convergence theorem, we have, up to a subsequence,

$$\int_{\mathbb{R}^N} |\nabla w(z)|^2 \frac{z + y_n}{|z + y_n|} dz \longrightarrow \int_{\mathbb{R}^N} |\nabla w(z)|^2 \xi dz \neq 0 \quad (3.5)$$

for some $\xi \in \mathbb{R}^N$ with $|\xi| = 1$. Since $\beta(u_n) = 0$ for every n , by (3.3), (3.4) and (3.5), we get a contradiction. \square

We set $\Phi : \{V \in L^{N/2} : V \geq 0, \|V\|_{N/2} < S\} \times \mathbb{R}^N \longrightarrow \mathcal{N}^V$

$$\Phi(V, y) = t_{w_y}^V w_y \doteq \Phi_y^V.$$

We observe that Φ is continuous because the function $y \mapsto w_y$ is continuous with respect to the strong topology of $\mathcal{D}^{1,2}$ (see Lemma 3.1) and $(y, V) \mapsto t_{w_y}^V$ is continuous for (iv) of Lemma 2.3. Finally, we set, for $R > 0$,

$$\Sigma_R^V = \{\Phi_y^V : |y| \leq R\} \text{ and } \Gamma_R^V = \{\Phi_y^V : |y| = R\}.$$

We have the following lemma:

Lemma 3.6. *There exists $R_0 > 0$ such that $\mathcal{B}_0 \cap \Gamma_R^V = \emptyset$ for every $R > R_0$ and for every $V \in L^{N/2}(\mathbb{R}^N)$ with $\|V\|_{N/2} < S$.*

Proof. We shall evaluate separately the positive and negative part of the following expression:

$$\beta(\Phi_y^V) \cdot y = (t_{w_y}^V)^2 \int_{\mathbb{R}^N} |\nabla w_y|^2 \frac{x}{|x|} \cdot y.$$

First of all we choose $R > 0$ such that $\int_{B_R} |\nabla w(z)|^2 dz = \lambda > 0$ and we observe

that $\min_{B_R(y)} \frac{x}{|x|} \cdot y \geq |y| \frac{|y| - R}{|y| + R}$. For the positive part we have:

$$\begin{aligned} \int_{x \cdot y > 0} |\nabla w_y|^2 \frac{x}{|x|} \cdot y dx &\geq \int_{B_R(y)} |\nabla w(x-y)|^2 \frac{x}{|x|} \cdot y dx \\ &\geq \int_{B_R} |\nabla w(z)|^2 |y| \frac{|y| - R}{|y| + R} dz \geq \lambda |y| \frac{|y| - R}{|y| + R}. \end{aligned}$$

Regarding the negative part we have:

$$\begin{aligned} \left| \int_{x \cdot y < 0} |\nabla w(x-y)|^2 \frac{x}{|x|} \cdot y dx \right| &\leq \int_{\mathbb{R}^N \setminus B_{|y|}(y)} |\nabla w(x-y)|^2 |y| dx \\ &\leq |y| \int_{\mathbb{R}^N \setminus B_{|y|}} |\nabla w(z)|^2 dz. \end{aligned}$$

Hence

$$\int_{\mathbb{R}^N} |\nabla w_y|^2 \frac{x}{|x|} \cdot y dx \geq |y| \left(\frac{|y| - R}{|y| + R} - \int_{\mathbb{R}^N \setminus B_{|y|}} |\nabla w(z)|^2 dz \right) \longrightarrow +\infty$$

since $w \in \mathcal{D}^{1,2}(\mathbb{R}^N)$. This completes the proof. \square

Now we assume that m is an isolated critical value for F_0 on \mathcal{N}^0 , namely, let $m_1 > m$ be such that there are no critical values for F_0 in the interval (m, m_1) . With this assumption we have the following lemma:

Lemma 3.7. *There exists $\epsilon_0 > 0$ such that $\sup_{y \in \mathbb{R}^N} F_V(\Phi_y^V) < \min\{m_1, 2m\}$ for every*

$V \in L^{N/2}$ with $\|V\|_{N/2} < \epsilon_0$.

Proof. We observe that

$$\begin{aligned} |F_V(\Phi_y^V) - F_V(w_y)| &\leq \frac{|(t_{w_y}^V)^2 - 1|}{2} \int |\nabla w_y|^2 + |V|w_y^2 dx + \int |f(t_{w_y}^V) - f(w_y)| \\ &= \frac{|(t_{w_y}^V)^2 - 1|}{2} \int |\nabla w|^2 + |V|w_y^2 dx + |t_{w_y}^V - 1| \int |f'((\theta t_{w_y}^V + 1 - \theta)w_y)| dx \end{aligned}$$

whith $\theta \in (0, 1)$ suitably chosen. By Remark 2.2 we have that w_y is bounded in $L^p + L^q$, and by (i) and (ii) of Lemma 3.3 the argument of f' is bounded, so, by (iii) of Lemma 2.1, we have that the integral involving f' is bounded uniformly by a constant C for every $y \in \mathbb{R}^N$ and for every V with $\|V\|_{N/2} < S$. Hence:

$$|F_V(\Phi_y^V) - F_V(w_y)| \leq \frac{|(t_{w_y}^V)^2 - 1|}{2} (\|w\|_{\mathcal{D}^{1,2}}^2 + \|V\|_{N/2} \|w\|_{2^*}^2) + C |t_{w_y}^V - 1| \quad (3.6)$$

and, by (iv) of Lemma 3.3, we obtain that

$$\lim_{\|V\| \rightarrow 0} \sup_{y \in \mathbb{R}^N} |F_V(\Phi_y^V) - F_V(w_y)| = 0.$$

Finally, we have:

$$\begin{aligned} & \lim_{\|V\|_{N/2} \rightarrow 0} \sup_{y \in \mathbb{R}^N} F_V(\Phi_y^V) \\ & \leq \lim_{\|V\|_{N/2} \rightarrow 0} \left(\sup_{y \in \mathbb{R}^N} F_V(w_y) + \sup_{y \in \mathbb{R}^N} |F_V(\Phi_y^V) - F_V(w_y)| \right) \\ & = F_0(w) + \lim_{\|V\|_{N/2} \rightarrow 0} \sup_{y \in \mathbb{R}^N} \int_{\mathbb{R}^N} |V| w_y^2 = m \end{aligned}$$

and this gives the requested result. \square

Lemma 3.8. *For fixed V there exists $R_V > 0$ such that $F_V(\Phi_y^V) < \gamma^V$ for every $y \in \mathbb{R}^N$ with $|y| > R_V$.*

Proof. By inequality (3.6) and by the definition of $F_V(w_y)$ we get

$$\begin{aligned} F_V(\Phi_y^V) & \leq F_V(w_y) + |F_V(\Phi_y^V) - F_V(w_y)| \\ & \leq F_0(w) + \int V w_y^2 dx + \frac{|(t_{w_y}^V)^2 - 1|}{2} (\|w\|_{\mathcal{D}^{1,2}}^2 + \|V\|_{N/2} \|w\|_{2^*}^2) + C |t_{w_y}^V - 1|, \end{aligned}$$

hence, by (iii) of Lemma 3.3 and by the minimality of w for F_0 , it results

$$\lim_{|y| \rightarrow \infty} F_V(\Phi_y^V) \leq m.$$

The claim follows by Lemma 3.5. \square

Now we set

$$\mathcal{H}^V = \{h \in C(\mathcal{N}^V, \mathcal{N}^V) : h(u) = u, \forall u : F_V(u) \leq \gamma^V\}$$

and

$$c_R = \inf_{\mathcal{H}^V} \sup_{y \in B_R} F_V(h(\Phi_y^V)) = \inf_{\mathcal{H}^V} \sup F_V(h(\Sigma_R^V)).$$

Lemma 3.9. *Given $V \in L^{N/2}$, $\|V\|_{N/2} < S$ there exists r_V such that $h(\Sigma_r^V) \cap \mathcal{B}_0 \neq \emptyset$ for every $h \in \mathcal{H}^V$ and for every $r \geq r_V$.*

Proof. We will show that, given V there exists r_V such that, for any given $h \in \mathcal{H}^V$ there exists y with $|y| < r_V$ and $\beta(h(\Phi_y^V)) = 0$. We set $g = \beta \circ h \circ \Phi^V$. g is homotopic to the identity with the homotopy given by

$$G(t, \cdot) = tg + (1-t)Id.$$

We shall show that $0 \notin G(t, \partial B_R)$ for every $t \in [0, 1]$ if R is big enough. If we choose $R > \max\{R_V, R_0\}$, then, for every y such that $|y| = R$, since $h \in \mathcal{H}^V$, it results

$$tg(y) + (1-t)y = t\beta(h(\Phi_y^V)) + (1-t)y = t\beta(\Phi_y^V) + (1-t)y.$$

Considering the scalar product by y , by Lemma 3.6 we get

$$tg(y) + (1-t)y \cdot y = t(\beta(\Phi_y^V) \cdot y) + (1-t)|y|^2 > 0.$$

Hence

$$\deg(g, B_R, 0) = 1$$

and, setting $r_V = R$ we get the claim. \square

Now we are ready to prove our main result:

Proof of Theorem 1.1. By Lemma 3.7, for any given $V \in L^{N/2}$ such that $\|V\|_{N/2} < \epsilon_0$ it results $\sup_{y \in \mathbb{R}^N} F_V(\Phi_y^V) < \min\{m_1, 2m\}$. For any fixed V , by Lemma 3.9, we can find r_V such that $h(\Sigma_{r_V}^V) \cap \mathcal{B}_0 \neq \emptyset$ for every $h \in \mathcal{H}^V$. Hence, if we choose $R > \max\{R_V, r_V\}$ with R_V given by Lemma 3.8, we have:

$$m < \gamma^V \leq c_R = \inf_{h \in \mathcal{H}^V} \sup F_V(h(\Sigma_R^V)) < \min\{m_1, 2m\}.$$

Now we observe that, by the Splitting Lemma 2.4, the Palais–Smale condition holds in the set

$$\mathcal{N}^V \cap \{u \in \mathcal{D}^{1,2} : m < F_V(u) < \min\{m_1, 2m\}\}.$$

Now we can apply the deformation lemma for C^1 manifolds (see [16], [25]) to get that c_R is a critical level for the functional F_V . This completes the proof. \square

References

- [1] A. Ambrosetti, M. Badiale, and S. Cingolani, *Semiclassical states of nonlinear Schrödinger equations*, Arch. Rational Mech. Anal. **140** (1997), no. 3, 285–300.
- [2] A. Ambrosetti, V. Felli, and A. Malchiodi, *Ground states of nonlinear Schrödinger equations with potentials vanishing at infinity*, preprint.
- [3] A. Ambrosetti and P. H. Rabinowitz, *Dual variational methods in critical point theory and applications*, J. Funct. Anal. **14** (1973), 349–381.
- [4] V. Benci and G. Cerami, *Existence of positive solutions of the equation $-\Delta u + a(x)u = u^{(N+2)/(N-2)}$ in \mathbf{R}^N* , J. Funct. Anal. **88** (1990), no. 1, 90–117.
- [5] V. Benci and D. Fortunato, *A strongly degenerate elliptic equation arising from the semilinear Maxwell equations*, C. R. Math. Acad. Sci. Paris **319** (2004), 839–842.
- [6] V. Benci and D. Fortunato, *Towards a unified field theory for classical electrodynamics*, Arch. Ration. Mech. Anal. **173** (2004), no. 3, 379–414.
- [7] V. Benci, C.R. Grisanti, and A.M. Micheletti, *Existence and non existence of the ground state solution for the nonlinear Schrödinger equations with $V(\infty) = 0$* , to appear in Topol. Methods in Nonlinear Anal.

- [8] V. Benci and A. M. Micheletti, *Solutions in exterior domains of null mass scalar field equations*, Preprint Dipartimento di Matematica Applicata “U. Dini” – Università di Pisa.
- [9] H. Berestycki and P.-L. Lions, *Nonlinear scalar field equations. I. Existence of a ground state*, Arch. Rational Mech. Anal. **82** (1983), no. 4, 313–345.
- [10] ———, *Nonlinear scalar field equations. II. Existence of infinitely many solutions*, Arch. Rational Mech. Anal. **82** (1983), no. 4, 347–375.
- [11] J. Berg and J. Löfström, *Interpolation spaces*, Springer Verlag, Berlin Heidelberg New York, 1976.
- [12] C. V. Coffman and M.M. Marcus, *Existence theorems for superlinear elliptic Dirichlet problems in exterior domains*, Preprint.
- [13] C. V. Coffman, *Uniqueness of the ground state solution for $\Delta u - u + u^3 = 0$ and a variational characterization of other solutions*, Arch. Rational Mech. Anal. **46** (1972), 81–95.
- [14] J. M. Coron, *Topologie te cas limite des injections de Sobolev*, C. R. Acad. Sci. Paris **299** (1984), 209–212.
- [15] M. J. Esteban and P. L. Lions, *Existence and non-existence results for semilinear elliptic problems in unbounded domains*, Proc. Royal Edinburgh Soc. **93 A** (1982), 1–14.
- [16] M. Ghoussoub, *Duality and perturbation methods in critical point theory*, Cambridge University Press, 1993.
- [17] B. Gidas, W. M. Ni, and L. Nirenberg, *Symmetry of positive solutions of nonlinear elliptic equations in \mathbf{R}^n* , Mathematical Analysis and Applications, Part A, Advances in Mathematics Supplementary Studies, vol. 7 A, Academic Press, 1981.
- [18] J. A. Hempel, *Multiple solutions for a class of nonlinear boundary value problems.*, Indiana Univ. Math. J. **20** (1971), 983–996.
- [19] H. Hofer, *Variational and topological methods in partially ordered Hilbert spaces.*, Math. Ann. **261** (1982), 493–514.
- [20] P. L. Lions, *The concentration-compactness principle in the Calculus of Variations – The locally compact case – Part I*, Ann. Inst. H. Poincaré – Analyse Nonlineaire **1** (1984), 109–145.
- [21] ———, *The concentration-compactness principle in the Calculus of Variations – The locally compact case – Part II*, Ann. Inst. H. Poincaré – Analyse Nonlineaire **1** (1984), 223–283.
- [22] Z. Nehari, *On a class of nonlinear second-order differential equations*, Trans. Amer. Math. Soc. **95** (1960), 101–123.
- [23] L. Pisani, *Remark on the sum of Lebesgue spaces*, Preprint.
- [24] S. I. Pohožaev, *On the eigenfunctions of the equation $\Delta u + \lambda f(u) = 0$* , Dokl. Akad. Nauk SSSR **165** (1965), 36–39.
- [25] P. H. Rabinowitz, *Minimax methods in critical point theory with applications to differential equations*, CBMS Regional Conference Series in Mathematics, vol. 65, Published for the Conference Board of the Mathematical Sciences, Washington, DC, 1986.

- [26] W. A. Strauss, *Existence of solitary waves in higher dimensions*, Comm. Math. Phys. **55** (1977), 149–162.
- [27] M. Struwe, *A global compactness result for elliptic boundary value problems involving limiting nonlinearities*, Math. Z. **187** (1984), 511–517.

Vieri Benci, Carlo R. Grisanti and Anna Maria Micheletti
Dipartimento di Matematica Applicata “U. Dini”
Università di Pisa
V. Bonanno 25/b
Pisa
Italy
e-mail: benci@dma.unipi.it
grisanti@dma.unipi.it
a.micheletti@dma.unipi.it

Asymptotic Behavior of a Bernoulli–Euler Type Equation with Nonlinear Localized Damping

R.C. Charão, E. Bisognin, V. Bisognin and A.F. Pazoto

Abstract. This work is devoted to prove the polynomial decay for the energy of solutions of a nonlinear plate equation of Bernoulli-Euler type with a nonlinear localized damping term. Following the methods in [20], which combines energy estimates, multipliers and compactness arguments the problem is reduced to a unique continuation question. In [24] the case where the damping is linear was solved. In this article we address the general case and obtain explicit rates of decay that depend on the growth of the dissipative term near zero and infinity.

1. Introduction

1.1. Setting of the problem

The main purpose of the paper is to study the asymptotic stability of the solutions of the Bernoulli–Euler type equation with a nonlinear damping term localized in a neighborhood of a suitable subset of the domain under consideration:

$$\begin{cases} u_{tt} + \Delta^2 u - \alpha \left(\int_{\Omega} |\nabla u|^2 dx \right) \Delta u + \rho(x, u_t) = 0 & \text{in } \Omega \times (0, \infty), \\ u = \frac{\partial u}{\partial \eta} = 0, & \text{in } \Gamma \times (0, \infty), \\ u(x, 0) = u_0, \quad u_t(x, 0) = u_1, & \text{on } \Omega, \end{cases} \quad (1)$$

where Ω is a bounded domain in \mathbb{R}^n of C^2 class, Γ denotes the boundary of Ω and α is a positive constant. In the classical Bernoulli–Euler model the shape of the function $\alpha = \alpha(\cdot)$ is given a priori.

It is interesting to observe that when $n = 1$ the model considered here is a general mathematical formulation of a problem arising in the dynamic buckling of a hinged extensible beam under an axial force. If $n = 2$, equations in (1) represent the “Berger approximation” of the full dynamic the von Kármán system modelling the

nonlinear vibrations of a plate. A rigorous mathematical justification for this fact was given in [17], [18], and also in [16], where the uniform exponential stabilization of both models was obtained as singular limit of the uniform stabilization of the von Kármán system of beams and plates.

In order to state precisely the problem under consideration we need some notations. Let us assume that the boundary $\Gamma = \partial\Omega$ of the bounded domain Ω is such that $\Gamma = \Gamma_0 \cup \Gamma_1$. We fix $x_0 \in \mathbb{R}^n$ and set

$$\Gamma_0 = \{x \in \partial\Omega ; (x - x_0) \cdot \eta > 0\} \quad \text{and} \quad \Gamma_1 = \Gamma \setminus \Gamma_0 \quad (2)$$

where $\eta = \eta(x)$ is the outward unit normal at $x \in \Gamma$.

The total energy associated with (1) is given by

$$E(t) = \frac{1}{2} \int_{\Omega} (u_t^2 + |\Delta u|^2) dx + \frac{\alpha}{4} \left(\int_{\Omega} |\nabla u|^2 dx \right)^2 \quad \forall t \geq 0. \quad (3)$$

Therefore, if we assume that

$$\rho(x, s)s \geq 0, \quad \forall (x, s) \in \Omega \times \mathbb{R}, \quad (4)$$

the following dissipation law holds:

$$E(t) - E(t+T) = \int_t^{t+T} \int_{\Omega} \rho(x, u_t) u_t dx, \quad \forall t \text{ and } T \geq 0. \quad (5)$$

Consequently, $E(t)$ is a non increasing function and the following basic question arises: Does $E(t) \rightarrow 0$ as $t \rightarrow \infty$ and, if yes, is it possible to find a rate of decay of $E(t)$?

When $\rho(x, s) = s$, it is straightforward to see from (5) that the energy decays uniformly exponentially as t goes to infinity. The same holds when $\rho(x, s) \equiv a(x)s$ with $a \in L^\infty$ and $a(x) \geq \rho_0 > 0$ a.e. in Ω . The analysis of stabilization when the damping is effective only on a subset of Ω is much more subtle. Such problem has been extensively investigated in context of wave equations and there is a large literature on the subject. Firstly, we mention the works of Dafermos [5], Haraux [6] and Slemrod [23], where La Salle's invariance principle was used as a tool to obtain asymptotic stability properties. In these papers, authors are interested in finding a class of feedbacks as large as possible which permit obtaining the decay of the solutions to equilibrium. None of the them studied the decay estimates. More recently, assuming that the dissipation is effective in a suitable subset of the domain where the solution holds, decay rates have been obtained (see for instance [2], [20], [22], [25] and the references therein). Roughly speaking, the most recent results on the subject were obtained for $\rho = \rho(x, s)$ behaving as $a(x)s|s|^\gamma$, where γ is a suitable constant, in general, $-1 \leq \gamma < \infty$, and the function $a = a(x)$ is as follows:

$$\begin{cases} a \in L^\infty(\Omega) \text{ and } a(x) \geq a_0 \text{ a.e in } \omega \\ \text{where } \omega \text{ is a neighborhood of } \Gamma_0. \end{cases} \quad (6)$$

The same problems have also been addressed for the Bernoulli–Euler equation. First we mention the work [22] where explicit estimates of decay of solutions

of (1) were obtained when $\alpha \equiv 0$ and $\rho(x, t) = a(x)g(t)$ with a as in (6) and $g(t)$ is monotonic and has certain growth properties near the origin and at infinity. The method of proof is direct and is based on the multiplier techniques, on some integral inequalities due to Haraux and Komornik (see for instance [7], [8] and [11]), and on a judicious idea due to Conrad and Rao used in [4] to study the nonlinear boundary stabilization of the wave equation. As will become clear during the proofs, the results obtained here improve in some sense the result obtained in [22]. A similar analysis was done in [24] where the exponential decay of the total energy (3) was obtained by letting $\rho(x, s) = a(x)s$, with $a = a(x)$ satisfying (6), and $\alpha > 0$. We recall that, in view of (5), the problem of exponential decay of $E(t)$ can be stated in the following equivalent form: To find $T > 0$ and $C > 0$ such that

$$E(0) \leq C \int_0^T \int_{\Omega} \rho(x, u_t) u_t dx dt \quad (7)$$

holds for every finite energy solution of (1). More precisely, the above inequality combined with the semigroup property, allows to obtain that, for any $R > 0$, there exist positive constants $C = C(R)$ and $\beta(R)$ satisfying

$$E(t) \leq C(R) E(0) e^{-\beta(R)t}, \quad \forall t > 0,$$

provided $E(0) \leq R$. However, it is not given any estimate on how the decay rate depends on the radius of the ball. This has been done, as far as we know, in very few cases and always using some structural condition on the nonlinearity. We refer to [25] for the case of the semilinear wave equation with localized damping and to [19] for the analysis of the von Kármán system of thermoelastic plates where an explicit estimate on how the decay rate tends to zero as $R \rightarrow \infty$ is provided. Moreover, it is important to emphasize that, in the general multi-dimensional setting, inequalities of the form (7) are valid if and only if a suitable Geometric Control Condition is satisfied (see [3]): it requires that every ray geometric optics reaches the region in which the damping mechanism is effective in a uniform time, a property that holds in the particular case where ω is given by (6).

Our purpose in this work is to give sufficient hypotheses on the function $\rho = \rho(x, t)$ so that we can obtain precise estimates of decay to the energy $E(t)$. As far as we know, the situation we are considering here has not been addressed in the literature yet since, to our knowledge, the existing results on decay rates for Bernoulli–Euler like equations with localized damping requires $\rho(x, s) = a(x)s$ or $\alpha = 0$ (see [22] and [24]). To obtain the result we make use of multipliers, a common tool that has been used in the study of the exact controllability and stabilization problems for the wave equation and some plate models. This leads to special difference inequalities for the energy of solutions and allows to apply the method developed in [20]. However, this method produces some lower order terms that we handle by compactness. The problem is then reduced to showing that the unique solution of (1) such that $u \equiv 0$ in $\omega \times \mathbb{R}$ is the trivial one, which requires the application of a unique continuation result proved in [10]. At this point, we observe that the unique continuation result in [10] applies only when ω

is neighborhood of the whole boundary, which leads us to require such assumption in our present proofs. In other words, the decay of solutions of (1) is obtained localizing the damping function in a neighborhood of the whole boundary Γ (see (8) and Remark 3.5).

Our main result (Theorem 1.2) shows that under suitable assumptions on the growth of the function $\rho = \rho(x, t)$ the energy of solutions goes to zero, as $t \rightarrow \infty$, with a polynomial rate of decay which is uniform on each bounded set $E(0) \leq R$ of initial data. To be more specific, we shall assume that the function $\rho(x, s)$ satisfies the growth condition

$$\begin{cases} c_1 a(x) |s|^{r+1} \leq |\rho(x, s)| \leq c_2 a(x) [|s|^{r+1} + |s|], & |s| \leq 1, \forall x \in \Omega \\ c_3 a(x) |s|^{p+1} \leq |\rho(x, s)| \leq c_4 a(x) [|s|^{p+1} + |s|], & |s| > 1, \forall x \in \Omega, \end{cases} \quad (8)$$

for some positive constants $c_i, i = 1, 2, 3, 4, a = a(x)$ satisfying

$$\begin{cases} a \in L^\infty(\Omega) \text{ and } a(x) \geq a_0 \text{ a.e in } \omega \\ \text{where } \omega \text{ is a neighborhood of } \Gamma \end{cases}$$

and

$$\begin{cases} -1 < r < \infty, \\ -1 < p \leq \frac{2}{n-2} \text{ if } n \geq 3 \text{ and } -1 < p < \infty \text{ if } n = 1, 2. \end{cases}$$

In addition, we suppose that

$$\begin{cases} \rho(x, s)s \geq 0 \text{ and } \frac{\partial \rho}{\partial s}(x, s) \geq 0, \forall (x, s) \in \Omega \times \mathbb{R}; \\ \rho(\cdot, s) \text{ and } \frac{\partial \rho}{\partial s}(\cdot, s) \in C(\bar{\Omega}). \end{cases} \quad (9)$$

Let us observe that a function ρ satisfying (8) is not necessarily globally Lipschitz and the class of functions satisfying (8) includes functions like $a(x)|s|^{\gamma-1}s$, $\gamma > 1$. Furthermore, one can proceed as in [1], [9] and [15] to consider more general growth assumptions on the behavior of the damping function. Indeed, following methods used in the works of P. Martinez and F. Alabau-Boussouira it is possible to derive an estimate like $E(t) \leq C (G^{-1}(1/t))^2, \forall t > 0$. In this case, $G(v) = v g(v)$ with $g: R \rightarrow R$ being an odd function, strictly increasing, of class C^1 , and $\rho(x, v)$ is assumed to grow linearly with $a(x)|v|$ if $|v| \geq 1$ and to have a behaviour dictated by g close to the origin, i.e.,

$$a(x) g(|v|) \leq |\rho(x, v)| \leq C a(x) g^{-1}(|v|) \quad (*)$$

if $|v| \leq 1$. Here, $a(x)$ is the function which localizes the dissipation.

In the present work, we have $\rho(x, v)$ with polynomial growth far from the origin and similar behavior close to the origin. We prefer to have a strongly non-linear (polynomial) growth far from the origin instead of a more general setting close to the origin (as in (*)) at the price of having a linear behavior far from the origin. The work where one successfully combines ρ with general (as in [1] and

[15]) behavior close to the origin and polynomial like growth far from the origin seems to be an open problem, which we would like to investigate in the future.

Now we can state our main result:

1.2. Main results

Before stating the main result of this paper, for the sake of completeness, we briefly recall the following result on existence (and uniqueness) for the Bernoulli–Euler type. According to the previous results existing in the literature, it can be summarized as follows:

Theorem 1.1. *Suppose that $\rho = \rho(x, t)$ satisfies (8) and (9). Then, for each $T > 0$, we have:*

1. *If $u_0 \in H^4(\Omega) \cap H_0^2(\Omega)$ and $u_1 \in H_0^2(\Omega)$, then system (1) admits an unique solution having the regularity*

$$u \in \mathcal{C}([0, T]; H^4(\Omega) \cap H_0^2(\Omega)) \cap \mathcal{C}^1([0, T]; H_0^2(\Omega)).$$

2. *If $u_0 \in H_0^2(\Omega)$ and $u_1 \in L^2(\Omega)$, then system (1) admits an unique solution having the regularity*

$$u \in \mathcal{C}([0, T]; H_0^2(\Omega)) \cap \mathcal{C}^1([0, T]; L^2(\Omega)).$$

The existence of both strong and weak solutions may be proven either by the theory of semigroup or by the Galerkin method.

The main result of this paper reads as follows:

Theorem 1.2. *Let $(u_0, u_1) \in H_0^2(\Omega) \times L^2(\Omega)$ and $R > 0$ such that*

$$\|(u_0, u_1)\|_{H_0^2(\Omega) \times L^2(\Omega)} \leq R.$$

Then, under the conditions of Theorem 1.1, the total energy $E(t)$ associated with the solutions of (1) has the following asymptotic behavior in time:

$$E(t) \leq C(1+t)^{-\gamma_i} \quad i = 1, 2, 3, 4,$$

where $C = C(R, E(0))$ is a positive constant and the decay rates γ_i are given according to the cases:

Case 1. *If $r \geq 0$ and $0 \leq p \leq \frac{2}{n-2}$, then*

$$\gamma_1 = \min \left\{ \frac{4}{3r+2}, \frac{8(p+1)}{4-p(n+2)} \right\} \text{ for } 3 \leq n < 6 \text{ and } p(n+2) < 4 \text{ or } n \geq 6.$$

When $n = 1, 2$ and $0 \leq p < \infty$ or $3 \leq n < 6$ and $p(n+2) \geq 4$, we have

$$\gamma_1 = \frac{4}{3(r+2)}.$$

Case 2. *If $r \geq 0$ and $-1 < p < 0$, then*

$$\gamma_2 = \min \left\{ \frac{4}{3r+2}, \frac{4}{8+3p(2-n)} \right\}.$$

When $n = 1, 2$, we have $\gamma_2 = \frac{4}{3r+2}$.

Case 3. If $-1 < r < 0$ and $0 \leq p \leq \frac{2}{n-2}$, then

$$\gamma_3 = \min \left\{ \frac{-2(r+1)}{r}, \frac{8(p+1)}{4-p(n+2)} \right\} \text{ for } n \geq 6 \text{ or } 3 \leq n < 6 \text{ and } p(n+2) < 4.$$

When $3 \leq n < 6$ and $p(n+2) \geq 4$ or $n = 1, 2$ and $1 \leq p < \infty$, we have $\gamma_3 = \frac{-2(r+1)}{r}$.

Case 4. If $-1 < r < 0$ and $-1 < p < 0$, then

$$\gamma_4 = \min \left\{ \frac{-2(r+1)}{r}, \frac{4}{8+3p(2-n)} \right\}.$$

When $n = 1, 2$, we have $\gamma_4 = \frac{-2(r+1)}{r}$.

The rest of the paper is organized as follows: In Section 2 we present some technical lemmas which are useful for the proof of Theorem 1.2. Section 3 is devoted to derive some energy inequalities and in Section 4 we prove Theorem 1.2.

2. Technical Lemmas

Now we are going to state some technical results that are crucial in the proof of Theorem 1.2. The first of them is the following Nakao's Lemma. We refer to [21] for the proof.

Lemma 2.1 (Nakao). Let $\Phi(t)$ be a nonnegative function on \mathbb{R}^+ satisfying

$$\sup_{t \leq s \leq t+T} \Phi(s)^{1+\delta} \leq g(t) \{ \Phi(t) - \Phi(t+T) \}$$

with $T > 0$, $\delta \geq 0$ and $g(t)$ a nondecreasing continuous function. If $\delta > 0$, then $\Phi(t)$ has the decay property

$$\Phi(t) \leq \left\{ \Phi(0)^{-\delta} + \int_T^t g(s)^{-1} ds \right\}^{-1/\delta}, \quad t \geq T.$$

The following result will also be needed:

Lemma 2.2 (Gagliardo–Nirenberg). Let $1 \leq r < p < \infty$, $1 \leq q \leq p$ and $0 \leq m$. Then, we have the inequality

$$\|v\|_{W^{k,q}} \leq C \|v\|_{W^{m,p}}^\theta \|v\|_{L^r}^{1-\theta}$$

for $v \in W^{m,p}(\Omega) \cap L^r(\Omega)$, where C is a positive constant and

$$\theta = \left(\frac{k}{n} + \frac{1}{r} - \frac{1}{q} \right) \left(\frac{m}{n} + \frac{1}{r} - \frac{1}{p} \right)^{-1}$$

provided that $0 < \theta \leq 1$.

In order to state the next results, we introduce a vector field $h = (h^1, h^2, \dots, h^n) : \overline{\Omega} \rightarrow \mathbb{R}^n$ of C^1 class satisfying

$$\begin{cases} h(x) = \eta(x) & \text{on } \Gamma_0 \\ h(x) \cdot \eta(x) \geq 0 & \text{on } \Gamma, \\ h(x) = 0 & \text{in } \Omega \setminus \widehat{\omega} \end{cases} \quad (10)$$

where $\eta = \eta(x)$ is the outward unit normal at x and $\widehat{\omega}$ is a open set in \mathbb{R}^n with the property

$$\Gamma_0 \subset \widehat{\omega} \cap \overline{\Omega} \subset \omega.$$

We also take a function $m \in W^{2,\infty}(\Omega)$ such that $\frac{|\nabla m|^2}{m}$ and $\frac{|\Delta m|^2}{m}$ are bounded and

$$\begin{cases} 0 \leq m(x) \leq 1 & \text{in } \Omega, \\ m = 1 & \text{in } \widetilde{\omega}, \\ m = 0 & \text{in } \overline{\Omega} \setminus \omega, \end{cases} \quad (11)$$

with $\widetilde{\omega} \subset \overline{\Omega}$ being an open set in $\overline{\Omega}$ satisfying

$$\Gamma_0 \subset \widetilde{\omega} \subset \omega \subset \overline{\Omega}.$$

For the existence of such functions we refer to Haraux [8] and Tucsnack [24].

Using the above notations we now state the energy identities that are the basis for obtaining the estimates of decay:

Lemma 2.3 (Energy Identities). *Let u be the solution of (1) and $T > 0$ fixed. Then, the following identities holds for all $t \geq 0$:*

$$\begin{aligned} & \int_t^{T+t} \int_{\Omega} [-|u_t|^2 + |\Delta u|^2] dx ds + \alpha \int_t^{T+t} \left(\int_{\Omega} |\nabla u|^2 dx \right)^2 ds \\ & = - \int_{\Omega} u_t u dx \Big|_t^{t+T} - \int_t^{T+t} \int_{\Omega} \rho(x, u_t) u dx ds \end{aligned} \quad (12)$$

$$\begin{aligned} & \int_t^{T+t} \int_{\Omega} m(x) [|\Delta u|^2 - |u_t|^2 + \alpha \|\nabla u\|^2 |\nabla u|^2] dx ds \\ & = - \int_{\Omega} m(x) u u_t dx \Big|_t^{T+t} - \int_t^{T+t} \int_{\Omega} m(x) \rho(x, u_t) u dx ds \\ & \quad - \int_t^{T+t} \int_{\Omega} [u \Delta u \Delta m + 2 \Delta u (\nabla u \cdot \nabla m)] dx ds \\ & \quad - \alpha \int_t^{T+T} \|\nabla u\|^2 \int_{\Omega} u (\nabla u \cdot \nabla m) dx ds \end{aligned} \quad (13)$$

$$\begin{aligned}
& \frac{1}{2} \int_t^{T+t} \int_{\Gamma} (h \cdot \eta) |\Delta u|^2 d\Gamma ds \\
&= \int_{\Omega} (h(x) \cdot \nabla u) u_t dx \Big|_t^{T+t} + \int_t^{T+t} \int_{\Omega} (h(x) \cdot \nabla u) \rho(x, u_t) dx ds \\
&+ \frac{1}{2} \int_t^{T+t} \int_{\Omega} \operatorname{div} h [|u_t|^2 - |\Delta u|^2 - \alpha \| |\nabla u|^2 | \nabla u|^2] dx ds \\
&+ \alpha \int_t^{T+t} \int_{\Omega} \| |\nabla u|^2 \| \sum_{j,k=1}^n D_j h^k D_j u D_k u dx ds + \int_t^{T+t} \int_{\Omega} (\Delta h \cdot \nabla u) \Delta u dx ds \\
&+ 2 \int_t^{T+t} \int_{\Omega} \sum_{j,k=1}^n D_j h^k (D_j D_k u) \Delta u dx ds
\end{aligned} \tag{14}$$

$$\begin{aligned}
& \int_{\Omega} ((x - x_0) \cdot \nabla u) u_t dx \Big|_t^{t+T} + \int_t^{t+T} \int_{\Omega} ((x - x_0) \cdot \nabla u) \rho(x, u_t) dx ds \\
&+ \frac{n}{2} \int_t^{t+T} \int_{\Omega} |u_t|^2 dx ds + (2 - \frac{n}{2}) \int_t^{t+T} \int_{\Omega} |\Delta u|^2 dx ds \\
&+ (\alpha - \frac{\alpha n}{2}) \int_t^{t+T} \| |\nabla u|^4 \| ds = \frac{1}{2} \int_t^{t+T} \int_{\Gamma} (x - x_0) \cdot \eta |\Delta u|^2 d\Gamma ds,
\end{aligned} \tag{15}$$

where $h = h(x)$ and $m = m(x)$ were given in (10) and (11), respectively.

Proof. Identities (12), (13) and (14) are obtained in a standard way multiplying the equation in (1) by $M(u) = u$, $M(u) = m(x)u$ and $M(u) = h(x) \cdot \nabla u$, respectively, and integrating over $\Omega \times [t, t+T]$ (see [13], p. 244). Identity (15) is a particular case of (14) when $h(x) = (x - x_0)$. We observe that properties (10) and (11) are not necessary to obtain identities (14) and (13), respectively. \square

3. Main estimates

In the sequel we derive some energy estimates that combined with Lemma 2.1 allow to proof Theorem 1.2. It is enough to consider $u_0 \in H^4(\Omega) \cap H_0^2(\Omega)$, $u_1 \in H_0^2(\Omega)$ and then to use a density argument.

By C we will represent different positive constants.

Lemma 3.1. *There exists a fixed $T > 0$ such that the total energy associated with (1) satisfies*

$$\begin{aligned}
E(t) &\leq C \{ E(t) - E(t+T) + \int_t^{t+T} \int_{\Omega} |\rho(x, u_t)| (|u| + |\nabla u|) dx ds \\
&+ \int_t^{t+T} \int_{\omega} (|u_t|^2 + |u|^2 + |\nabla u|^2) dx ds \}, \quad \forall t > 0
\end{aligned} \tag{16}$$

where C is a positive constant.

Proof. We fix a positive number β satisfying $\frac{n\beta}{2} - 1 > 0$. If $n \geq 3$, we also take β such that $\beta < \frac{2}{n-2}$. Then, multiplying (15) by β and adding (12) we obtain

$$\begin{aligned} & \int_t^{t+T} \int_{\Omega} \left[\left(\frac{n\beta}{2} - 1 \right) |u_t|^2 + \left(1 + \beta \left(2 - \frac{n}{2} \right) \right) |\Delta u|^2 \right] dx ds \\ & + \alpha \left(1 + \beta \left(1 - \frac{n}{2} \right) \right) \int_t^{t+T} \|\nabla u\|^4 ds \\ & = - \int_{\Omega} \left[\beta(x - x_0) \cdot \nabla u - u \right] u_t dx \Big|_t^{t+T} + \frac{\beta}{2} \int_t^{t+T} \int_{\Gamma} (x - x_0) \cdot \eta |\Delta u|^2 d\Gamma ds \\ & - \int_t^{t+T} \int_{\Omega} \left[\beta(x - x_0) \cdot \nabla u + u \right] \rho(x, u_t) dx ds. \end{aligned} \tag{17}$$

Therefore, choosing $\gamma = \min \left\{ 2 \left(\frac{n\beta}{2} - 1 \right); 2 \left(1 + \beta \left(2 - \frac{n}{2} \right) \right); 4 \left(1 + \beta \left(1 - \frac{n}{2} \right) \right) \right\}$ it follows that

$$\begin{aligned} \gamma \int_t^{t+T} E(s) ds & \leq \int_{\Omega} [\beta|x - x_0| |\nabla u| + |u|] |u_t| dx \Big|_t^{t+T} \\ & + \int_t^{t+T} \int_{\Omega} [\beta|x - x_0| |\nabla u| + |u|] |\rho(x, u_t)| dx ds \\ & + \frac{\beta}{2} \int_t^{t+T} \int_{\Gamma_0} (x - x_0) \cdot \eta |\Delta u|^2 d\Gamma ds, \end{aligned} \tag{18}$$

because $(x - x_0) \cdot \eta < 0$ on $\Gamma \setminus \Gamma_0$. Moreover, denoting $M_0 = \sup_{x \in \bar{\Omega}} |x - x_0|$, we deduce that

$$\begin{aligned} \gamma \int_t^{t+T} E(s) ds & \leq \int_{\Omega} [\beta M_0 |\nabla u| + |u|] |u_t| dx \Big|_t^{t+T} \\ & + \int_t^{t+T} [\beta M_0 |\nabla u| + |u|] |\rho(x, u_t)| dx ds + \frac{\beta}{2} \int_t^{t+T} \int_{\Gamma_0} (x - x_0) \cdot \eta |\Delta u|^2 d\Gamma ds. \end{aligned} \tag{19}$$

Now, using Poincaré's inequality it results

$$\begin{aligned} \gamma \int_t^{t+T} E(s) ds & \leq C \|u_t\| \|\Delta u\| \Big|_t^{t+T} + \int_t^{t+T} \int_{\Omega} |\rho(x, u_t)| [|u| + \beta M_0 |\nabla u|] dx ds \\ & + \frac{\beta}{2} \int_t^{t+T} \int_{\Gamma_0} (x - x_0) \cdot \eta |\Delta u|^2 d\Gamma ds, \end{aligned} \tag{20}$$

and according to (5) we get

$$\begin{aligned} \gamma \int_t^{t+T} E(s) ds &\leq C [E(t) + E(t+T)] + \int_t^{t+T} \int_{\Omega} |\rho(x, u_t)| [|u| + \beta M_0 |\nabla u|] dx ds \\ &+ \frac{\beta}{2} \int_t^{t+T} \int_{\Gamma_0} (x - x_0) \cdot \eta |\Delta u|^2 d\Gamma ds. \end{aligned} \quad (21)$$

The next steps are devoted to estimate the last term in (21). In order to do that, first we observe that according to (10) and (14), the following holds:

$$\begin{aligned} \frac{1}{2} \int_t^{t+T} \int_{\Gamma_0} |\Delta u|^2 d\Gamma ds &= \frac{1}{2} \int_t^{t+T} \int_{\Gamma_0} h(x) \cdot \eta |\Delta u|^2 d\Gamma ds \\ &\leq \frac{1}{2} \int_t^{t+T} \int_{\Gamma} h(x) \cdot \eta |\Delta u|^2 d\Gamma ds \\ &= \int_{\Omega} (h \cdot \nabla u) u_t dx \Big|_t^{t+T} + \frac{1}{2} \int_t^{t+T} \int_{\Omega} \operatorname{div} h [|u_t|^2 - |\Delta u|^2 - \alpha |\nabla u|^2 |\nabla u|^2] dx ds \\ &+ \int_t^{t+T} \int_{\Omega} \rho(x, u_t) (h \cdot \nabla u) dx ds + \alpha \int_t^{t+T} \int_{\Omega} |\nabla u|^2 \sum_{j,k} D_j h^k D_j u D_k u dx ds \\ &+ 2 \int_t^{t+T} \int_{\Omega} \sum_{j,k} D_j h^k (D_j D_k u) \Delta u dx ds + \int_t^{t+T} \int_{\Omega} (\Delta h \cdot \nabla u) \Delta u dx ds. \end{aligned} \quad (22)$$

To estimate the terms in the right-hand side of (22) we proceed as follows. Since $h \in C^1(\overline{\Omega})$ and $h \equiv 0$ in $\Omega \setminus \widehat{\omega}$ we have

$$\int_{\Omega} (h \cdot \nabla u) u_t dx \Big|_t^{t+T} \leq C [E(t) + E(t+T)], \quad (23)$$

$$\int_t^{t+T} \int_{\Omega} \rho(x, u_t) (h \cdot \nabla u) dx ds \leq C \int_t^{t+T} \int_{\Omega} |\rho(x, u_t)| |\nabla u| dx ds \quad (24)$$

and

$$\begin{aligned} \int_t^{t+T} \int_{\Omega} \operatorname{div} h [|u_t|^2 - |\Delta u|^2 - \alpha |\nabla u|^2 |\nabla u|^2] dx ds \\ \leq C \int_t^{t+T} \int_{\widehat{\omega} \cap \overline{\Omega}} [|u_t|^2 + |\Delta u|^2 + |\nabla u|^2 |\nabla u|] dx ds. \end{aligned} \quad (25)$$

Now note that, since $\nabla u \equiv 0$ in $\overline{\omega} \cap \overline{\Omega}$, we can apply Poincaré's inequality to obtain

$$\begin{aligned} \int_t^{t+T} \int_{\Omega} (\Delta h \cdot \nabla u) \Delta u dx ds &\leq C \int_t^{t+T} \int_{\overline{\omega} \cap \overline{\Omega}} |\nabla u| |\Delta u| dx ds \\ &\leq C \int_t^{t+T} \left(\int_{\overline{\omega} \cap \overline{\Omega}} |\nabla u|^2 dx \right)^{\frac{1}{2}} \left(\int_{\overline{\omega} \cap \overline{\Omega}} |\Delta u|^2 dx \right)^{\frac{1}{2}} ds \leq C \int_t^{t+T} \int_{\overline{\omega} \cap \overline{\Omega}} |\Delta u|^2 dx ds. \end{aligned} \quad (26)$$

We also have

$$\begin{aligned} & \int_t^{t+T} \int_{\Omega} \sum_{j,k} D_j h^k (D_j D_k u) \Delta u dx ds \leq C \int_t^{t+T} \int_{\overline{\omega \cap \overline{\Omega}}} |D_j D_k u| |\Delta u| dx ds \\ & \leq C \int_t^{t+T} \left(\int_{\overline{\omega \cap \overline{\Omega}}} |\Delta u|^2 dx \right)^{\frac{1}{2}} \left(\int_{\overline{\omega \cap \overline{\Omega}}} |\Delta u|^2 dx \right)^{\frac{1}{2}} ds = C \int_t^{t+T} \int_{\overline{\omega \cap \overline{\Omega}}} |\Delta u|^2 dx ds \end{aligned} \quad (27)$$

and

$$\int_t^{t+T} \int_{\Omega} \|\nabla u\|^2 \sum_{j,k} D_j h^k D_j u D_k u dx ds \leq C \int_t^{t+T} \int_{\overline{\omega \cap \overline{\Omega}}} \|\nabla u\|^2 |\nabla u|^2 dx ds. \quad (28)$$

Now, replacing (23) up to (28) into (22) it follows that

$$\begin{aligned} & \frac{1}{2} \int_t^{t+T} \int_{\Gamma_0} |\Delta u|^2 d\Gamma ds \leq C \left\{ E(t) + E(t+T) + \int_t^{t+T} \int_{\overline{\omega \cap \overline{\Omega}}} |u_t|^2 dx ds \right. \\ & \left. + \int_t^{t+T} \int_{\Omega} |\rho(x, u_t)| |\nabla u| dx ds + \int_t^{t+T} \int_{\overline{\omega \cap \overline{\Omega}}} [\|\nabla u\|^2 |\nabla u|^2 + |\Delta u|^2] dx ds \right\}. \end{aligned} \quad (29)$$

In the sequel we are going to find boundaries for the last term of the right-hand side of (29). First, we use (13) with $m = m(x)$ given in (11) to write

$$\begin{aligned} & \int_t^{t+T} \int_{\Omega} m(x) [|\Delta u|^2 + \|\nabla u\|^2 |\nabla u|^2] dx ds \\ & \leq - \int_{\Omega} m(x) u u_t dx \Big|_t^{t+T} + \int_t^{t+T} \int_{\omega} |u_t|^2 dx ds \\ & \quad - \int_t^{t+T} \int_{\Omega} m(x) u \rho(x, u_t) dx ds - \int_t^{t+T} \int_{\Omega} [u \Delta u \Delta m + 2 \Delta u (\nabla u \cdot \nabla m)] dx ds \\ & \quad - \alpha \int_t^{t+T} \int_{\Omega} \|\nabla u\|^2 u (\nabla u \cdot \nabla m) dx ds. \end{aligned} \quad (30)$$

Recalling that $0 \leq m(x) \leq 1$ and letting

$$c_0 = \max \left\{ \sup_{x \in \Omega} \frac{|\nabla m(x)|^2}{m(x)}, \sup_{x \in \Omega} \frac{|\Delta m(x)|^2}{m(x)} \right\}$$

we can use Hölder's and Poincaré's inequalities to bind each term on the right-hand side of (30) as follows:

$$\int_t^{t+T} \int_{\Omega} m(x) u \rho(x, u_t) dx ds \leq \int_t^{t+T} \int_{\Omega} |\rho(x, u_t)| |u| dx dt, \quad (31)$$

$$\int_{\Omega} m(x) u u_t dx \Big|_t^{t+T} \leq C [E(t+T) + E(t)], \quad (32)$$

$$\begin{aligned}
& \int_t^{t+T} \int_{\omega} [u\Delta u\Delta m + 2\Delta u(\nabla u \cdot \nabla m)] dx ds \\
& \leq \int_t^{t+T} \int_{\omega} \left[\frac{|\Delta m|}{\sqrt{\frac{m}{2}}} |u| \sqrt{\frac{m}{2}} |\Delta u| + 2\sqrt{m} |\Delta u| |\nabla u| \frac{|\nabla m|}{\sqrt{m}} \right] dx ds \\
& \leq \int_t^{t+T} \int_{\omega} c_0 |u|^2 dx ds + \frac{1}{4} \int_t^{t+T} \int_{\omega} m(x) |\Delta u|^2 dx ds + \\
& \quad + 2\sqrt{c_0} \int_t^{t+T} \left(\int_{\omega} |\nabla u|^2 dx \right)^{\frac{1}{2}} \left(\int_{\omega} m |\Delta u|^2 dx \right)^{\frac{1}{2}} ds.
\end{aligned} \tag{33}$$

Now, choosing $k = 2\alpha c_0$ we have

$$\begin{aligned}
& -\alpha \int_t^{t+T} \int_{\Omega} \|\nabla u\|^2 u (\nabla u \cdot \nabla m) dx ds \\
& \leq \alpha \int_t^{t+T} \|\nabla u\|^2 \left[\frac{1}{2} \int_{\omega} k |u|^2 dx + \frac{1}{2} \int_{\omega} \frac{1}{k} |\nabla u|^2 |\nabla m|^2 dx \right] ds \\
& \leq C \int_t^{t+T} \int_{\omega} |u|^2 dx ds + \frac{1}{4} \int_t^{t+T} \int_{\Omega} \|\nabla u\|^2 m |\nabla u|^2 dx ds,
\end{aligned} \tag{34}$$

where $C = C(E(0))$ is a positive constant.

Thus, returning to (30) and using all the above estimate we get

$$\begin{aligned}
& \int_t^{t+T} \int_{\Omega} m(x) [|\Delta u|^2 + \|\nabla u\|^2 |\nabla u|^2] dx ds \\
& \leq C [E(t) + E(t+T) + \int_t^{t+T} \int_{\Omega} |\rho(x, u_t)| |u| dx ds \\
& \quad + \int_t^{t+T} \int_{\omega} [|u_t|^2 + |u|^2 + |\nabla u|^2] dx ds]
\end{aligned} \tag{35}$$

with $C = C(E(0)) > 0$. Moreover, since $0 \leq m(x) \leq 1$ and $m \equiv 1$ in $\widehat{\omega}$, it follows from (35) that

$$\begin{aligned}
& \int_t^{t+T} \int_{\overline{\Omega} \cap \widehat{\omega}} [|\Delta u|^2 + \|\nabla u\|^2 |\nabla u|^2] dx ds \\
& \leq C [E(t) + E(t+T) + \int_t^{t+T} \int_{\Omega} |\rho(x, u_t)| |u| dx ds \\
& \quad + \int_t^{t+T} \int_{\omega} [|u_t|^2 + |u|^2 + |\nabla u|^2] dx ds].
\end{aligned} \tag{36}$$

Finally, recalling that $\overline{\Omega} \cap \widehat{\omega} \subset \omega$, inequality (29) combined with (36) gives

$$\begin{aligned}
& \frac{1}{2} \int_t^{t+T} \int_{\Gamma_0} |\Delta u|^2 d\Gamma dt \leq C \left[E(t) + E(t+T) \right. \\
& \quad \left. + \int_t^{t+T} \int_{\Omega} |\rho(x, u_t)| [|u| + |\nabla u|] dx dt + \int_t^{t+T} \int_{\omega} [|u_t|^2 + |u|^2 + |\nabla u|^2] dx ds \right]
\end{aligned} \tag{37}$$

which suffices to conclude the proof of Lemma 3.1. Indeed, replacing (37) in (21) we obtain

$$\begin{aligned} \gamma \int_t^{t+T} E(s) ds &\leq C \left[E(t) + E(t+T) + \int_t^{t+T} \int_{\Omega} |\rho(x, u_t)| [|u| + |\nabla u|] dx dt \right. \\ &\quad \left. + \int_t^{t+T} \int_{\omega} |u_t|^2 dx ds + \int_t^{t+T} \int_{\Omega} [|u|^2 + |\nabla u|^2] dx ds \right], \end{aligned} \tag{38}$$

and since

$$TE(t+T) \leq \int_t^{t+T} E(s) dx$$

the result is obtained taking $T \geq \frac{2C}{\gamma} + 1$. □

Lemma 3.2. *Let $u = u(x, t)$ be the solution of (1) and ΔE be given by $\Delta E \equiv E(t) - E(t+T)$. For $T > 0$ given in Lemma 3.1 and $\rho = \rho(x, s)$ satisfying (8), the following holds:*

$$\begin{aligned} &\int_t^{t+T} \int_{\Omega} |\rho(x, u_t)| [|\nabla u| + |u|] dx ds \\ &\leq C (\Delta E)^{\frac{1}{r+2}} \sqrt[4]{E(t)} + C (\Delta E)^{\frac{p+1}{p+2}} E(t)^{\frac{4+p(n+2)}{8(p+2)}} \end{aligned} \tag{39}$$

for the case $r \geq 0$, $0 \leq p \leq \frac{2}{n-2}$ and $n \geq 3$. If $n = 2$, this estimate holds for the case $r \geq 0$ and $p \geq 0$.

$$\begin{aligned} &\int_t^{t+T} \int_{\Omega} |\rho(x, u_t)| [|\nabla u| + |u|] dx ds \\ &\leq C (\Delta E)^{\frac{1}{r+2}} \sqrt[4]{E(t)} + C (\Delta E)^{\frac{2}{4+(2-n)p}} \sqrt[4]{E(t)} \end{aligned} \tag{40}$$

for the case $r \geq 0$, $-1 < p < 0$ and $n \geq 2$.

$$\begin{aligned} &\int_t^{t+T} \int_{\Omega} |\rho(x, u_t)| [|\nabla u| + |u|] dx ds \\ &\leq C (\Delta E)^{\frac{r+1}{r+2}} \sqrt{E(t)} + C (\Delta E)^{\frac{p+1}{p+2}} E(t)^{\frac{4+p(n+2)}{8(p+2)}} \end{aligned} \tag{41}$$

for the case $-1 < r < 0$, $0 \leq p \leq \frac{2}{n-2}$ and $n \geq 3$. If $n = 2$, the estimate holds for the case $-1 < r < 0$, $p \geq 0$.

$$\begin{aligned} &\int_t^{t+T} \int_{\Omega} |\rho(x, u_t)| [|\nabla u| + |u|] dx ds \\ &\leq C (\Delta E)^{\frac{r+1}{r+2}} \sqrt{E(t)} + C (\Delta E)^{\frac{2}{4+p(2-n)}} \sqrt[4]{E(t)} \end{aligned} \tag{42}$$

for the case $-1 < r < 0$, $-1 < p < 0$ and $n \geq 2$, where C is a positive constant.

For $n = 1$ the above estimates are the same as for the case $n = 2$.

Proof. According to the hypotheses on the growth of ρ , we have

$$\begin{aligned}
& \int_t^{t+T} \int_{\Omega} |\rho(x, u_t)| |\nabla u| + |u| dx ds \\
& \leq \int_t^{t+T} \int_{\Omega_1} c_2 a(x) \{|u_t|^{r+1} + |u_t|\} [|\nabla u| + |u|] dx ds \\
& \quad + \int_t^{t+T} \int_{\Omega_2} c_4 a(x) \{|u_t|^{p+1} + |u_t|\} [|\nabla u| + |u|] dx ds = I_1 + I_2,
\end{aligned} \tag{43}$$

where

$$\Omega_1 = \{(x, t) \in \Omega \times \mathbb{R}^+ : |u(x, t)| \leq 1\} \quad \text{and} \quad \Omega_2 \setminus \Omega_1.$$

The statement of the lemma is proved after combining the estimates for I_1 and I_2 in the following cases:

Case 1: Estimating I_1 for $r \geq 0$ and $n \geq 2$.

Using Poincaré's inequality and (5) we obtain

$$\begin{aligned}
I_1 & \leq \|\sqrt{a}\|_{L^\infty(\Omega)} 2c_2 \int_t^{t+T} \int_{\Omega_1} \sqrt{a(x)} |u_t| (|\nabla u| + |u|) dx ds \\
& \leq C \left(\int_t^{t+T} \int_{\Omega_1} a(x) |u_t|^2 dx ds \right)^{\frac{1}{2}} \left(\int_t^{t+T} \int_{\Omega_1} (|\nabla u| + |u|)^2 dx ds \right)^{\frac{1}{2}} \\
& \leq C \left(\int_t^{t+T} \int_{\Omega_1} a(x) |u_t|^2 dx ds \right)^{\frac{1}{2}} \left(\int_t^{t+T} E(s) ds \right)^{\frac{1}{2}} \\
& \leq C \left(\int_t^{t+T} \int_{\Omega_1} a(x) |u_t|^{r+2} dx ds \right)^{\frac{1}{r+2}} \sqrt[4]{E(t)}
\end{aligned}$$

because $\frac{2}{r+2} + \frac{r}{r+2} = 1$, where C is a positive constant that depends on $|\Omega|$, $\|\sqrt{a}\|_{L^\infty(\Omega)}$ and T . Consequently, from (5) and (8) we get

$$I_1 \leq C \left(\int_t^{t+T} \int_{\Omega_1} \rho(x, u_t) u_t dx ds \right)^{\frac{1}{r+2}} \sqrt[4]{E(t)} \leq C (\Delta E)^{\frac{1}{r+2}} \sqrt[4]{E(t)}. \tag{44}$$

Case 2: Estimating I_1 for $-1 < r < 0$ and $n \geq 2$.

Using Poincaré and Hölder's inequalities together with (5) and (8), we have

$$\begin{aligned}
I_1 & \leq C \int_t^{t+T} \int_{\Omega_1} a(x) |u_t|^{r+1} [|\nabla u| + |u|] dx ds \\
& \leq C \left(\int_t^{t+T} \int_{\Omega_1} a(x) |u_t|^{r+2} dx ds \right)^{\frac{r+1}{r+2}} \left(\int_t^{t+T} \int_{\Omega} [|u| + |\nabla u|]^{r+2} dx ds \right)^{\frac{1}{r+2}} \\
& \leq C \left(\int_t^{t+T} \int_{\Omega_1} \rho(x, u_t) u_t dx ds \right)^{\frac{r+1}{r+2}} \left(\int_t^{t+T} \int_{\Omega} [|u| + |\nabla u|]^2 dx ds \right)^{\frac{1}{2}} \\
& \leq C (\Delta E)^{\frac{r+1}{r+2}} \sqrt{E(t)}
\end{aligned}$$

where $C > 0$ depends on r , $\|a\|_{L^\infty(\Omega)}$, $|\Omega|$ and T .

Case 3a: Estimating I_2 for $0 \leq p \leq \frac{2}{n-2}$ and $n \geq 3$.

$$\begin{aligned} I_2 &\leq 2c_4 \int_t^{t+T} \int_{\Omega_2} a(x) |u_t|^{p+1} (|\nabla u| + |u|) dx ds \\ &\leq C \left(\int_t^{t+T} \int_{\Omega_2} a(x) \frac{p+2}{p+1} |u_t|^{p+2} dx ds \right)^{\frac{p+1}{p+2}} \left(\int_t^{t+T} \int_{\Omega_2} (|\nabla u| + |u|)^{p+2} dx ds \right)^{\frac{1}{p+2}} \\ &\leq C \left(\int_t^{t+T} \int_{\Omega_2} a(x) |u_t|^{p+2} dx ds \right)^{\frac{p+1}{p+2}} \left(\int_t^{t+T} \int_{\Omega} |\nabla u|^{p+2} dx ds \right)^{\frac{1}{p+2}} \end{aligned}$$

where we have used Poincaré's inequality in $W_0^{1,p+2}(\Omega)$, Hölder's inequality and the hypothesis on the boundedness of $a(x)$. Now, using Gagliardo–Nirenberg and Poincaré's inequality we obtain

$$\begin{aligned} \|\nabla u\|_{L^{p+2}(\Omega)} &\leq C \|\nabla u\|_{H^1(\Omega)}^\theta \|\nabla u\|_{L^2(\Omega)}^{1-\theta} \leq C \|u\|_{H^2(\Omega) \cap H_0^1(\Omega)}^\theta \|\nabla u\|_{L^2(\Omega)}^{1-\theta} \\ &\leq C \|\Delta u\|_{L^2(\Omega)}^\theta \|\nabla u\|_{L^2(\Omega)}^{1-\theta} \leq C E(t)^{\frac{\theta}{2}} E(t)^{\frac{1-\theta}{4}} = C E(t)^{\frac{1+\theta}{4}} \end{aligned}$$

for $\theta = \frac{np}{2(p+2)}$. Then, from (5) and (8) it follows that

$$I_2 \leq C \left(\int_t^{t+T} \int_{\Omega_2} \rho(x, u_t) u_t dx ds \right)^{\frac{p+1}{p+2}} \|\nabla u\|_{L^{p+2}(\Omega)} \leq C (\Delta E)^{\frac{p+1}{p+2}} E(t)^{\frac{4+p(n+2)}{8(p+2)}}.$$

Case 3b: Estimating I_2 for $p \geq 0$ and $n = 2$.

Since $u_t \in H^2(\Omega)$, $\nabla u \in H^1(\Omega) \hookrightarrow L^q(\Omega)$, $\forall q \geq 1$. Therefore, due to Sobolev's inequality it follows that

$$\begin{aligned} I_2 &\leq c_4 \int_t^{t+T} \int_{\Omega_2} a(x) [|u_t|^{p+1} + |u_t|] (|\nabla u| + |u|) dx ds \\ &\leq 2c_4 \int_t^{t+T} \int_{\Omega_2} |u_t|^{p+1} (|\nabla u| + |u|) dx ds \\ &\leq C \left(\int_t^{t+T} \int_{\Omega_2} a(x) |u_t|^{p+2} dx ds \right)^{\frac{p+1}{p+2}} \left(\int_t^{t+T} \int_{\Omega_2} [|\nabla u| + |u|]^{p+2} dx ds \right)^{\frac{1}{p+2}} \\ &\leq C \left(\int_t^{t+T} \int_{\Omega_2} a(x) |u_t|^{p+2} dx ds \right)^{\frac{p+1}{p+2}} \left(\int_t^{t+T} \int_{\Omega_2} |\nabla u|^{p+2} dx ds \right)^{\frac{1}{p+2}}. \end{aligned}$$

Now, using Gagliardo–Nirenberg's Lemma with $\theta = \frac{p}{p+2}$ we have

$$\begin{aligned} \|\nabla u\|_{L^{p+2}(\Omega)} &\leq \|\nabla u\|_1^\theta \|\nabla u\|^{1-\theta} \leq C \|\Delta u\|^\theta E(t)^{\frac{1-\theta}{4}} \\ &\leq C E(t)^{\frac{\theta}{2}} E(t)^{\frac{1-\theta}{4}} = C E(t)^{\frac{p+1}{2(p+2)}}. \end{aligned}$$

Consequently,

$$I_2 \leq C \left(\int_t^{t+T} \int_{\Omega} \rho(x, u_t) dx ds \right)^{\frac{p+1}{p+2}} E(t)^{\frac{p+1}{2(p+2)}}.$$

Case 4a: Estimating I_2 for $-1 < p < 0$ and $n \geq 3$.

Again, combining (8), Poincaré and Hölder's inequalities we get

$$\begin{aligned} I_2 &\leq c_4 \int_t^{t+T} \int_{\Omega_2} a(x) [|u_t|^{p+1} + |u_t|] (|\nabla u| + |u|) dx ds \\ &\leq 2c_4 \int_t^{t+T} \int_{\Omega_2} a(x) |u_t| (|\nabla u| + |u|) dx ds \\ &\leq C \left(\int_t^{t+T} \int_{\Omega_2} a(x) |u_t|^2 dx ds \right)^{\frac{1}{2}} \left(\int_t^{t+T} \int_{\Omega_2} |\nabla u|^2 dx ds \right)^{\frac{1}{2}} \\ &\leq C \left(\int_t^{t+T} \int_{\Omega_2} a(x) |u_t|^2 dx ds \right)^{\frac{1}{2}} \sqrt{T} \sqrt[4]{E(t)} \\ &\leq C \left(\int_t^{t+T} \int_{\Omega_2} a(x) |u_t|^{\lambda l'} dx ds \right)^{\frac{1}{2l'}} \left(\int_t^{t+T} \int_{\Omega_2} |u_t|^{(2-\lambda)l} dx ds \right)^{\frac{1}{2l'}} \sqrt[4]{E(t)}. \end{aligned}$$

where l' is the conjugate of l . Now, choosing $\lambda = \frac{4(p+2)}{4+p(2-n)}$ and $l = \frac{2n}{(n-2)(2-\lambda)}$, we have $l' = \frac{p+2}{\lambda}$ and

$$\begin{aligned} I_2 &\leq C \left(\int_t^{t+T} \int_{\Omega_2} a(x) |u_t|^{p+2} dx ds \right)^{\frac{2}{4+p(2-n)}} \left(\int_t^{t+T} \int_{\Omega_2} |u_t|^{\frac{2n}{n-2}} dx ds \right)^{\frac{p(2-n)}{2(4+p(2-n))}} \sqrt[4]{E(t)} \\ &\leq C \left(\int_t^{t+T} \int_{\Omega_2} \rho(x, u_t) u_t dx ds \right)^{\frac{2}{4+p(2-n)}} \sqrt[4]{E(t)} \leq C (\Delta E)^{\frac{2}{4+p(2-n)}} \sqrt[4]{E(t)} \end{aligned}$$

because $u_t \in L^\infty(0, \infty; H^1(\Omega)) \hookrightarrow L^\infty(0, \infty; L^{\frac{2n}{n-2}}(\Omega))$.

Case 4b: Estimating I_2 for $-1 < p < 0$ and $n = 2$.

$$\begin{aligned} I_2 &\leq c_4 \int_t^{t+T} \int_{\Omega_2} a(x) [|u_t|^{p+2} + |u_t|] (|\nabla u| + |u|) dx ds \\ &\leq C \int_t^{t+T} \int_{\Omega_2} a(x) |u_t| (|\nabla u| + |u|) dx ds \\ &\leq C \left(\int_t^{t+T} \int_{\Omega_2} a(x) |u_t|^2 dx ds \right)^{\frac{1}{2}} \left(\int_t^{t+T} \int_{\Omega_2} |\nabla u|^2 dx ds \right)^{\frac{1}{2}} \\ &\leq C \left(\int_t^{t+T} \int_{\Omega_2} a(x) |u_t|^2 dx ds \right)^{\frac{1}{2}} \sqrt[4]{E(t)} \end{aligned}$$

due to Poincaré’s inequality. Consequently,

$$\begin{aligned} I_2 &\leq C \left(\int_t^{t+T} \int_{\Omega_2} a(x) |u_t|^{p+2} dx ds \right)^{\frac{1}{4}} \left(\int_t^{t+T} \int_{\Omega_2} |u_t|^{2-p} dx ds \right)^{\frac{1}{4}} \sqrt[4]{E(t)} \\ &\leq C \left(\int_t^{t+T} \int_{\Omega_2} \rho(x, u_t) u_t dx ds \right)^{\frac{1}{4}} \sqrt{E(t)} \leq C(\Delta E)^{\frac{1}{4}} \sqrt[4]{E(t)} \end{aligned}$$

where we have used (5) and (8) and the fact that $u_t \in L^\infty(0, \infty; H^1(\Omega)) \hookrightarrow L^\infty(0, \infty; L^q(\Omega))$, $\forall q \geq 1$ and $n = 2$. The case $n = 1$ is trivial due to the Sobolev Imbedding $L^\infty(0, \infty; H^1(\Omega)) \hookrightarrow L^\infty(0, \infty; \Omega)$, and the estimates obtained are the same as for the case $n = 2$.

Thus, combining the above estimates with (43) we conclude the proof of Lemma 3.2. \square

As a consequence of Lemma 3.1, Lemma 3.2 and Young’s inequality, we obtain the following result:

Proposition 3.3. *Let $u = u(x, t)$ be the solution of (1) and ΔE be given by $\Delta E \equiv E(t+T) - E(t)$. For $T > 0$ given in Lemma 3.1 and $\rho = \rho(x, s)$ satisfying (8), the energy associated with (1) satisfies*

$$E(t) \leq C \left\{ D_i(t)^2 + \int_t^{t+T} \int_{\omega} (|u_t|^2 + |u| + |\nabla u|^2) dx ds \right\}, \quad i \in \{1, 2, 3, 4\}$$

where

$$D_1(t)^2 = \Delta E + (\Delta E)^{\frac{4}{3(r+2)}} + (\Delta E)^{\frac{8(p+1)}{12+p(6-n)}}$$

if $r \geq 0$ and $0 \leq p \leq \frac{2}{n-2}$ ($0 \leq p < \infty$ if $n = 2$),

$$D_2(t)^2 = \Delta E + (\Delta E)^{\frac{4}{3(r+2)}} + (\Delta E)^{\frac{4}{12+3p(2-n)}}$$

if $r \geq 0$ and $-1 \leq p < 0$,

$$D_3(t)^2 = \Delta E + (\Delta E)^{\frac{2(r+1)}{r+2}} + (\Delta E)^{\frac{8(p+1)}{12+p(6-n)}}$$

if $-1 < r < 0$ and $0 \leq p \leq \frac{2}{n-2}$ ($0 \leq p < \infty$ if $n = 2$),

$$D_4(t)^2 = \Delta E + (\Delta E)^{\frac{2(r+1)}{4+2}} + (\Delta E)^{\frac{4}{12+3p(2-n)}}$$

if $-1 < r < 0$, $-1 < p < 0$ and $n \geq 2$.

For $n = 1$, the above estimates are the same as for the case $n = 2$.

Proof. As we said before, the proof is obtained combining Lemma 3.1, Lemma 3.2 and Young’s inequality. \square

Proposition 3.4. *According to each $D_i = D_i(t)$ given in Proposition 3.3 there exists a constant $C > 0$ such that*

$$\int_t^{t+T} \int_{\Omega} [|u|^2 + |\nabla u|^2] dx ds \leq C \left\{ D_i(t)^2 + \int_t^{t+T} \int_{\omega} |u_t|^2 dx ds \right\} \quad (45)$$

when u is the solution of (1) with initial data u_0 and u_1 satisfying $E(0) \leq R$, where $R > 0$ is fixed and $C = C(R)$.

Proof. Let us argue by contradiction following the so-called “compactness–uniqueness” argument. Suppose that (45) is not valid. Then, there will exist a sequence $\{t_n\}_{n \geq 1} \subset \mathbb{R}$ and a sequence of solutions $\{u_n\}_{n \geq 1}$ with initial data u_0^n, u_1^n such that

$$\lim_{n \rightarrow \infty} \frac{\int_{t_n}^{t_n+T} \int_{\Omega} [|u_n|^2 + |\nabla u_n|^2] dx ds}{D_i(t_n)^2 + \int_{t_n}^{t_n+T} \int_{\omega} |u_{n,t}|^2 dx ds} = \infty. \quad (46)$$

Let

$$\lambda_n^2 = \int_{t_n}^{t_n+T} \int_{\Omega} [|u_n|^2 + |\nabla u_n|^2] dx ds \quad (47)$$

and

$$I_n(t_n)^2 = \frac{1}{\lambda_n^2} \left[D_i(t_n)^2 + \int_{t_n}^{t_n+T} \int_{\omega} |(u_n)_t|^2 dx ds \right]. \quad (48)$$

Then, from (46) we have

$$I_n(t_n)^2 \longrightarrow 0, \quad \text{as } n \rightarrow \infty. \quad (49)$$

Moreover, letting $v_n(x, t) = \frac{u_n(x, t + t_n)}{\lambda_n}$, $0 \leq t \leq T$, it follows that

$$\begin{aligned} 1 &= \frac{1}{\lambda_n^2} \int_{t_n}^{t_n+T} \int_{\Omega} [|u_n(x, s)|^2 + |\nabla u_n(x, s)|^2] dx ds \\ &= \frac{1}{\lambda_n^2} \int_0^T \int_{\Omega} [|u_n(x, t + t_n)|^2 + |\nabla u_n(x, t + t_n)|^2] dx dt \\ &= \int_0^T \int_{\Omega} [|v_n(x, t)|^2 + |\nabla v_n(x, t)|^2] dx dt, \end{aligned}$$

that is,

$$\int_0^T \int_{\Omega} [|v_n(x, t)|^2 + |\nabla v_n(x, t)|^2] dx dt = 1, \quad \forall n \in \mathbb{N}. \quad (50)$$

On the other hand, in view of Proposition 3.3 and (50) we get

$$\begin{aligned} &E_1(v_n(t)) \\ &= E_1\left(\frac{u_n(t + t_n)}{\lambda_n}\right) = \frac{1}{\lambda_n^2} E_1(u_n(t + t_n)) \leq \frac{1}{\lambda_n^2} E(u_n(t + t_n)) \leq \frac{1}{\lambda_n^2} E(u_n(t_n)) \\ &\leq \frac{C}{\lambda_n^2} \left\{ D_i(t_n)^2 + \int_{t_n}^{t_n+T} \int_{\omega} |u_{n,t}|^2 dx ds + \int_{t_n}^{t_n+T} \int_{\Omega} [|u_n|^2 + |\nabla u_n|^2] dx ds \right\} \\ &= C I_n(t_n)^2 + \frac{C}{\lambda_n^2} \int_{t_n}^{t_n+T} \int_{\Omega} [|u_n(x, s)|^2 + |\nabla u_n(x, s)|^2] dx ds \\ &= C I_n(t_n)^2 + C \int_0^T \int_{\Omega} [|v_n(x, t)|^2 + |\nabla v_n(x, t)|^2] dx dt = C [I_n(t_n)^2 + 1]. \end{aligned}$$

where we have denoted $u_{n,t} = \frac{\partial u_n}{\partial t}$, and $E_1(t)$ is the part of the energy that remains after taking $\alpha = 0$. The above estimate together with (49) tell us that

$$E_1(v_n(t)) \leq C$$

for all $0 \leq t \leq T$ and $n \in \mathbb{N}$, where C is a positive constant independent on n and t . Consequently,

$$\|v_{n,t}(t)\|_{L^2(\Omega)} \leq C \text{ and } \|\Delta v_n(t)\|_{L^2(\Omega)} \leq C. \quad (51)$$

Furthermore, from Poincaré's inequality we have

$$\begin{aligned} \|v_n(t)\|_{L^2(\Omega)}^2 &= \int_{\Omega} |v_n(x,t)|^2 dx = \int_{\Omega} \frac{1}{\lambda_n^2} |u_n(x,t+t_n)|^2 dx \\ &\leq C_1 \int_{\Omega} \frac{1}{\lambda_n^2} |\nabla u_n(x,t+t_n)|^2 dx = C_1 \int_{\Omega} |\nabla v_n(x,t)|^2 dx \leq C \end{aligned} \quad (52)$$

for all $0 \leq t \leq T$ and $n \in \mathbb{N}$, where C is a positive constant independent on n and t .

Combining the above estimates, we deduce that

$$\{v_n\} \text{ is bounded in } W^{1,\infty}([0,T], L^2(\Omega)) \cap L^\infty([0,T], H_0^2(\Omega)). \quad (53)$$

Now, the idea we have in mind is to pass $\{v_n\}$ to the limit in order to apply UCP. However, before we do that we have to check that the following holds:

$$\lim_{n \rightarrow \infty} \frac{1}{\lambda_n} \rho(x, u_{n,t}(t+t_n)) = 0 \text{ in } L^1([0,T] \times \Omega). \quad (54)$$

Indeed, recalling the definition of Ω_1 and Ω_2 introduced in (43), it follows from (8) that

$$\begin{aligned} \int_0^T \int_{\Omega} |\rho(x, u_{n,t}(x,t+t_n))| dx dt &= \int_{t_n}^{t_n+T} \int_{\Omega} |\rho(x, u_{n,t})| dx ds \\ &\leq \int_{t_n}^{t_n+T} \int_{\Omega_1} c_2 a(x) [|u_{n,t}|^{r+1} + |u_{n,t}|] dx ds \\ &\quad + \int_{t_n}^{t_n+T} \int_{\Omega_2} c_4 a(x) [|u_{n,t}|^{p+1} + |u_{n,t}|] dx ds. \end{aligned} \quad (55)$$

Then, the proof of (54) is divided in four cases:

Case 1: $0 \leq r \leq 2$, $0 \leq p \leq \frac{2}{2-n}$ if $n > 2$ and $0 \leq p < \infty$ if $n = 1, 2$.

First observe that, since $a(\cdot) \in L^\infty(\Omega)$ we get

$$\int_t^{t+T} \int_{\Omega} |\rho(x, u_t)| dx dt \leq C \{ [E(t) - E(t+T)]^{\frac{1}{r+2}} + [E(t) - E(t+T)]^{\frac{p+1}{p+2}} \}.$$

Thus, if $n > 1$, it follows from the definition of $D_1(t)$ in Proposition (3.3) that

$$\int_{t_n}^{t_n+T} \int_{\Omega} |\rho(x, u_{n,t})| dx dt \leq C [D_1(t_n)^{\frac{3}{2}} + D_1(t_n)^{\frac{12+p(6-n)}{4(p+2)}}].$$

If $n = 1$, the estimate is the same as for $n = 2$. On the other hand, since $E(0) \leq R$, $E(u_n(0)) \leq R$ as well and therefore, thanks to Poincaré's inequality, we have

$$\begin{aligned} \lambda_n &\leq C \left(\int_{t_n}^{t_n+T} \|\nabla u_n(s)\|^2 ds \right)^{\frac{1}{2}} \leq C \left(\int_{t_n}^{t_n+T} \|\Delta u_n(s)\|^2 ds \right)^{\frac{1}{2}} \leq C E(u_n(0)) \\ &\leq C R. \end{aligned}$$

Thus, putting these last two inequalities together with (48) and (49), we deduce that

$$\frac{1}{\lambda_n} \int_{t_n}^{t_n+T} \int_{\Omega} |\rho(x, u_{n,t})| dx ds \rightarrow 0 \quad \text{as } n \rightarrow \infty,$$

and, consequently, (54) holds.

Case 2: $0 \leq r < \infty$, $-1 < p < 0$ and $n \geq 1$.

In this case, we also proceed as in the proof of Lemma (3.2) and use Proposition (3.3) to obtain

$$\begin{aligned} \int_t^{t+T} \int_{\Omega} |\rho(x, u_t)| dx dt &\leq C \{ [E(t) - E(t+T)]^{\frac{1}{r+2}} + [E(t) - E(t+T)] \} \\ &\leq C [D_2(t) + D_2(t)^{\frac{3}{2}}]. \end{aligned}$$

Then, using again (48)–(49) we may conclude that

$$\begin{aligned} \frac{1}{\lambda_n} \int_{t_n}^{t_n+T} \int_{\Omega} |\rho(x, u_{n,t})| dx dt &\leq C [I_n(t_n) + \frac{1}{\lambda_n} D_2(t_n)^{\frac{3}{2}}] \\ &\leq C [I_n(t_n) + \lambda_n^{\frac{1}{2}} I_n(t_n)^{\frac{3}{2}}] \rightarrow 0 \end{aligned}$$

as $n \rightarrow \infty$, because λ_n is bounded. Therefore, (54) holds.

Case 3: $-1 < r < 0$, $0 \leq p \leq \frac{2}{n-2}$, if $n > 2$ or $0 \leq p < \infty$ if $n = 1, 2$.

Arguing as in Case 2, i.e., performing as in Lemma 3.2 and using the definition of $D_3(t)$ in Proposition 3.3, we get

$$\begin{aligned} \int_t^{t+T} \int_{\Omega} |\rho(x, u_t)| dx dt &\leq C \{ [E(t) - E(t+T)]^{\frac{r+1}{r+2}} + [E(t) - E(t+T)]^{\frac{p+1}{p+2}} \} \\ &\leq C [D_3(t) + D_3(t)^{\frac{12+p(6-n)}{4(p+2)}}]. \end{aligned}$$

Now, using (48)–(49) we deduce that

$$\begin{aligned} \frac{1}{\lambda_n} \int_{t_n}^{t_n+T} \int_{\Omega} |\rho(x, u_{n,t})| dx dt &\leq C [I_n(t_n) + \frac{1}{\lambda_n} D_3(t_n)^{\frac{12+p(6-n)}{4(p+2)}}] \\ &\leq C [I_n(t_n) + \lambda_n^{\frac{4+p(2-n)}{4(p+2)}} I_n(t_n)^{\frac{12+p(6-n)}{4(p+2)}}] \rightarrow 0, \end{aligned}$$

as $n \rightarrow \infty$, because λ_n is bounded.

Case 4: $-1 < r < 0$, $-1 < p < 0$ and $n \geq 1$.

In this case, it is easy to see that

$$\begin{aligned} \int_t^{t+T} \int_{\Omega} |\rho(x, u_t)| dx dt &\leq C \{ [E(t) - E(t+T)]^{\frac{r+1}{r+2}} + [E(t) - E(t+T)] \} \\ &\leq C [D_4(t) + D_4(t)^2] \end{aligned}$$

where we have used the definition of $D_4(t)$ in Proposition 3.3. Again, using (48)–(49) and the fact that λ_n is bounded we obtain the desired result.

Now, using (53) and the classical Aubin–Lions’s Theorem we can extract a subsequence of $\{v_n\}$, which we also denote by $\{v_n\}$, such that

$$v_n \longrightarrow v \text{ in } L^2(0, T; H_0^1(\Omega)),$$

and by (50) we get

$$\|v\|_{L^2(0, T; H^1(\Omega))} = 1. \quad (56)$$

Moreover, from (48)–(49) we get

$$\int_0^T \int_{\omega} |v_t|^2 dx dt = 0.$$

According to the previous analysis, the limit v satisfies

$$\begin{cases} v \in W^{1, \infty}(0, T; L^2(\Omega)) \cap L^{\infty}(0, T; H_0^2(\Omega)) \\ v_{tt} + \Delta^2 v - \alpha \left(\int_{\Omega} |\nabla v|^2 dx \right) \Delta v = 0 & \text{in } \Omega \times (0, T) \\ v = \frac{\partial v}{\partial \eta} = 0 & \text{in } \Gamma \times (0, T) \\ v_t = 0, & \text{in } \omega \times (0, T). \end{cases} \quad (57)$$

So, by the UCP proved in [10] and [24] we have $v \equiv 0$ in $\Omega \times (0, T)$, which contradicts (56). Then, necessarily, (45) holds and the proof of Proposition 3.4 is complete. \square

Remark 3.5. The hypothesis that ω is a neighborhood of the whole boundary Γ is crucial to obtain, via UCP, the Proposition 3.4 and, consequently, the Theorem of stabilization. However, throughout the paper it can be seen that this assumption is not necessary to obtain the previous results (Lemmas 3.1, 3.2 and Proposition 3.3). This is a purely technical problem that might be overcome by proving the UCP for solutions of (57) when ω is only a neighborhood of Γ_0 .

4. Proof of the main result

It is enough to consider $u_0 \in H^4(\Omega) \cap H_0^2(\Omega)$, $u_1 \in H_0^2(\Omega)$ and then to use a density argument.

From Proposition 3.3 and Proposition 3.4 we get

$$E(t) \leq C \left\{ D_i(t) + \int_t^{t+T} \int_{\omega} |u_t|^2 dx ds \right\}, \quad (58)$$

where $D_i(t)$, $i = 1, 2, 3, 4$, was given in Proposition 3.3.

Now, in order to derive the decay estimate we shall estimate the last term in (58):

We see from (6) that

$$\int_t^{t+T} \int_\omega |u_t|^2 dx ds \leq \frac{1}{a_0} \int_t^{t+T} \int_\Omega a(x) |u_t|^2 dx ds. \quad (59)$$

So, performing as in Lemma 3.2 we may obtain the same estimates for the right-hand side of (60). Indeed, for the case $0 \leq p \leq \frac{2}{n-2}$, $n > 2$ and $0 \leq r < \infty$, we use Hölder's inequality to obtain

$$\begin{aligned} & \int_t^{t+T} \int_\omega |u_t|^2 dx ds \\ & \leq C \left\{ \int_t^{t+T} \int_{\Omega_1} a(x) |u_t|^2 dx ds + \int_t^{t+T} \int_{\Omega_2} a(x) |u_t|^2 dx ds \right\} \\ & \leq C \left\{ \left[\int_t^{t+T} \int_{\Omega_1} a(x) |u_t|^{r+2} dx ds \right]^{\frac{2}{r+2}} + \int_t^{t+T} \int_{\Omega_2} a(x) |u_t|^{p+2} \right\} \\ & \leq C \left\{ \left[\int_t^{t+T} \int_{\Omega_1} \rho(x, u_t) u_t dx ds \right]^{\frac{2}{r+2}} + \int_t^{t+T} \int_{\Omega_2} \rho(x, u_t) u_t dx ds \right\}, \end{aligned} \quad (60)$$

with Ω_1 and Ω_2 introduced in the proof of Lemma 3.2. Now, recalling the notation $\Delta E = E(t) - E(t+T)$, the above inequality together with (5) give us that

$$\int_t^{t+T} \int_\omega |u_t|^2 dx ds \leq C \{ \Delta E + (\Delta E)^{\frac{2}{r+2}} \} \quad (61)$$

where C depends on $|\Omega|$, T , and $\|a\|_\infty$. Therefore, from (58) we get

$$E(t) \leq C \left\{ \Delta E + (\Delta E)^{\frac{2}{r+2}} + (\Delta E)^{\frac{4}{3(r+2)}} + (\Delta E)^{\frac{8(p+1)}{12+p(6-n)}} \right\}. \quad (62)$$

Consequently, since $E(t)$ is bounded, the following holds:

$$\sup_{t \leq s \leq t+T} E(s)^{\frac{1}{K_1}} \leq C [E(t) - E(t+T)], \quad (63)$$

where

$$K_1 = \min \left\{ \frac{4}{3(r+2)}, \frac{8(p+1)}{12+p(6-n)} \right\}. \quad (64)$$

We note that, if $n = 1, 2$ or $3 \leq n < 6$ and $p(n+2) \geq 4$ then $K_1 = \frac{4}{3(r+2)}$.

Now, setting $1 + \gamma = \frac{1}{K_1}$, we have $\gamma = \frac{1 - K_1}{K_1}$ and applying Lemma 2.1, we obtain

$$E(t) \leq C_1 (1+t)^{-\gamma_1} \quad (65)$$

with $\gamma_1 = \min \left\{ \frac{4}{3r+2}, \frac{8(p+1)}{4-p(n+2)} \right\}$ if $n \geq 6$ or $3 \leq n < 6$ and $p(n+2) < 4$. If $n = 1, 2$ or $p(n+2) \geq 4$ and $3 \leq n < 6$, we have $\gamma_1 = \frac{4}{3r+2}$.

The rest of the proof is obtained in a similar way, i.e., performing as before we conclude that

$$K_2 = \min \left\{ \frac{4}{3(r+2)}, \frac{4}{12+3p(2-n)} \right\},$$

if $r \geq 0$, $-1 < p < 0$ and $n > 2$. For $n = 1, 2$, we have $K_2 = \frac{2}{r+2}$.

$$K_3 = \min \left\{ \frac{2(r+1)}{r+2}, \frac{8(p+1)}{12+p(6-n)} \right\},$$

if $-1 < r < 0$, $0 \leq p \leq \frac{2}{n-2}$ and $n \geq 6$ or $p(n+2) < 4$, $0 \leq p \leq \frac{2}{n-2}$ and $3 \leq n < 6$. When $n = 1, 2$ or $3 \leq n < 6$ and $p(n+2) \geq 4$ we get $K_3 = \frac{2(r+1)}{r+2}$.

Finally,

$$K_4 = \min \left\{ \frac{2(r+1)}{r+2}, \frac{4}{12+3p(2-n)} \right\}$$

if $-1 < r < 0$, $-1 < p < 0$ and $n > 2$. Again, for $n = 1, 2$, we get $K_4 = \frac{2(r+1)}{r+2}$.

Then, letting $1 + \gamma = \frac{1}{K_i}$, $i = 2, 3, 4$, and using Lemma 2.1 we obtain the corresponding γ_i given in the statement of Theorem 1.2. \square

Acknowledgements. We would like to thank the Referee for the constructive criticism which allows us to correct and clarify several items in our earlier version.

References

- [1] F. Alabau-Boussouira, Convexity and weighted integral inequalities for energy decay rates of nonlinear dissipative hyperbolic systems, *Appl Math. Optim.* **51** (2005) 61–105.
- [2] M.A. Astaburuaga and R.C. Charão, Stabilization of the total energy for a system of elasticity with localized dissipation, *Diff. Int. Equations* **15** (11) (2002) 1357–1376.
- [3] C. Bardos, G. Lebeau and J. Rauch, Sharp sufficient conditions for the observation, control and stabilization from the boundary, *SIAM J. Control and Opt.* **30** (1992) 1024–1065.
- [4] F. Conrad and B. Rao, Decay of solutions of wave equations in a star-shaped domain with nonlinear boundary feedback, *Asymptotic Anal.* **7** (1993) 159–177.
- [5] C.D. Dafermos, On the existence and the asymptotic stability of solutions to the equations of linear thermoelasticity, *Arch. Rational Mech. Anal.* **29** (1968) 241–271.
- [6] A. Haraux, Stabilization of trajectories for some weakly damped hyperbolic equations, *J. Diff. Equations* **59** (1985) 145–154.
- [7] A. Haraux, Oscillations forcées pour certains système dissipatifs nonlinéaires, *Publications du Laboratoire d'Analyse Numérique N° 78010*, Université Pierre et Marie Curie (1978).
- [8] A. Haraux, Semi-groupes linéaires equation d'évolution linéaires périodiques, *Publications du Laboratoire d'Analyse Numérique N° 78011*, Université Pierre et Marie Curie (1978).

- [9] M.A. Horn, Nonlinear boundary stabilization of a system of anisotropic elasticity with light internal damping, *Contemporary Mathematics* **268** (2000), 177–189.
- [10] J.U. Kim, Exact semi-internal controllability of an Euler–Bernoulli equation, *SIAM J. Control and Opt.* **30** (1992) 1001–1023.
- [11] V. Komornik, Exact controllability in ans Stabilization. The multiplier Method, Masson, Paris and Wiley, New York (1994).
- [12] I. Lasiecka and D. Tataru, Uniform boundary stabilization of semilinear wave equations with nonlinear boundary damping, *Diff. Int. Equations* **6** (1993), 507–533.
- [13] J.L. Lions, Contrôlabilité exacte, perturbations et stabilisation de systèmes distribués, Tome 1, Paris, Masson (1988).
- [14] P. Martinez, Boundary Stabilization of the Wave Equation in almost star-shaped domains, *SIAM J. Control Optim.* **37** (3)(1999), 673–694.
- [15] P. Martinez, A new method to obtain decay estimates for dissipative systems with localized damping, *Rev. Mat. Complut.* **12** (1)(1999), 251–283.
- [16] G. Perla Menzala, A.F. Pazoto and E. Zuazua, Stabilization of Berger–Timoshenko’s equation as limit of the uniform stabilization of the von Kármán system of beams and plates, *M2AN. Mathematical Modelling and Numerical Analysis* **36** (4) (2002), 657–691.
- [17] G. Perla Menzala and E. Zuazua, Timoshenko’s beam equation as a limit of a nonlinear one-dimensional von Kármán system, *Proc. Royal Soc. Edinburgh, Sect. A* **130** (2000), 855–875.
- [18] G. Perla Menzala and E. Zuazua, Timoshenko’s plate equation as singular limit of the dynamical von Kármán system, *J. Math. Pures Appl.* **79** (1) (2000), 73–94.
- [19] G. Perla Menzala and E. Zuazua, Explicit exponential decay rates for solutions of von Kármán system of thermoelastic plates, *C. R. Acad. Sci. Paris* **324** Série I (1997), 49–54.
- [20] M. Nakao, Decay of solutions of the wave equation with a local nonlinear dissipation, *Math. Ann.* **305** (3) (1996), 403–417.
- [21] M. Nakao, A difference inequality and application to nonlinear evolution equations, *J. Math. Soc. Japan*, **30** (1978) 747–762.
- [22] L.R. Roder Tcheugoué, Stabilization of the wave equation with localized nonlinear damping, *J. Diff. Equations* **145** (1998), 502–524.
- [23] M. Slemrod, Weak asymptotic decay via a “Relaxed Invariance Principle” for a wave equation with nonlinear, nonmonotone damping, *Proc. Royal Soc. Edinburgh* **113** (1989), 87–97.
- [24] M. Tucsnak, Semi-internal stabilization for a non-linear Bernoulli–Euler equation, *Math. Methods Appl. Sci.* **19** (1) (1996), 897–907.
- [25] E. Zuazua, Exponential decay for the semilinear wave equation with locally distributed damping, *Comm. in PDE* **15** (1990), 205–235.

R.C. Charão
Departamento de Matemática
Universidade Federal de Santa Catarina
P.O. Box 476
CEP 88040-900 Florianópolis, SC
Brasil
e-mail: charao@mtm.ufsc.br

E. Bisognin and V. Bisognin
Centro Universitário Franciscano
Campus Universitário
97010-032 Santa Maria, RS
Brasil
e-mail: eleni@unifra.br
vanilde@unifra.br

A.F. Pazoto
Instituto de Matemática
Universidade Federal do Rio de Janeiro
P.O. Box 68530
CEP 21945-970 Rio de Janeiro, RJ
Brasil
e-mail: ademir@acd.ufrj.br

T-minima

Lucio Boccardo

Abstract. Thanks to a suitable definition of minima involving the truncations (T-minima), we study the minimization of functionals, whose model is

$$\int_{\Omega} b(x, v) |\nabla v|^2 - \int_{\Omega} f(x) v(x), \quad f \in L^1.$$

Em homenagem ao aniversário de Djairo:

“ ... da la man destra mi lasciai Sibilia,
da l'altra gi m'avea lasciata Setta.”

(Inferno XXVI)

1. Introduction

In [2], thanks to a suitable definition of minima involving the truncations (T-minima), is proved the existence and uniqueness of minima of convex functionals of Calculus of Variations with principal part like

$$\int_{\Omega} a(x) |\nabla v|^2, \quad p > 1,$$

and linear term

$$\int_{\Omega} f(x) v(x)$$

where Ω is a bounded open set in \mathbb{R}^N . Moreover is proved the equivalence between T-minimization of energy functionals and existence of entropy solutions of the related Euler–Lagrange equations, under standard differentiability assumptions (see [1] for existence and uniqueness of entropy solutions of Dirichlet problems in L^1). Then it is proved that if $f(x) \in L^{p^*}(\Omega)$ (classical situation), then a T-minimum is a minimum.

Other results about T-minima can be found in [12], [14] (see also [13]).

Here, we study existence of T-minima if the functional contains a lower order term or if the principal part depends also on v (generalization of Theorem 7.1 in

[2]), like

$$\int_{\Omega} b(x, v) |\nabla v|^2.$$

Recall that in [9] is proved that the previous functional is convex if and only if the function $b(x, s)$ does not depend on s .

2. Assumptions

Let $f(x)$ be a measurable function and $j(x, s, \xi)$ be a function defined in $\Omega \times \mathbb{R} \times \mathbb{R}^N$, measurable with respect to x , continuous and increasing with respect to s and strictly convex with respect to ξ . Assume there exist $\alpha \in \mathbb{R}^+$ and a continuous function $\beta(s)$ such that

$$\alpha |\xi|^2 \leq j(x, s, \xi) \leq \beta(s) |\xi|^2, \quad \forall \xi \in \mathbb{R}^N, \text{ a.e. in } \Omega, \tag{2.1}$$

and define the functional

$$J(v) = \int_{\Omega} j(x, |v|, \nabla v) - \int_{\Omega} f(x)v(x).$$

We will need some results proved in [1].

Recall that $M^q(\Omega)$, $0 < q < +\infty$, denotes the Marcinkiewicz space of exponent q on Ω and the truncation $T_k : \mathbb{R} \mapsto \mathbb{R}$ is defined by

$$T_k(t) = \begin{cases} t, & |t| \leq k, \\ k \frac{t}{|t|}, & |t| > k. \end{cases}$$

Definition 2.1 ([1]). We define $\mathcal{T}_0^{1,2}(\Omega)$ as the set of measurable functions $u : \Omega \rightarrow \mathbb{R}$ such that $T_k(u)$ belongs to $W_0^{1,2}(\Omega)$ for every $k > 0$.

In [1] it is proved that it is possible to extend the notion of gradient to the functions in $\mathcal{T}_0^{1,2}(\Omega)$, defining ∇u as $\nabla T_k(u)$ on the set where $\{|u(x)| \leq k\}$.

Definition 2.2 ([2]). Let $f \in L^1(\Omega)$. A measurable function u is a T-minimum for the functional

$$J(v) = \int_{\Omega} j(x, |v|, \nabla v) - \int_{\Omega} f(x)v(x)$$

if

$$\left\{ \begin{array}{l} u \in \mathcal{T}_0^{1,2}(\Omega), \\ \int_{\{x \in \Omega: |u(x) - \varphi(x)| \leq k\}} j(x, |u|, \nabla u) \\ \leq \int_{\{x \in \Omega: |u(x) - \varphi(x)| \leq k\}} j(x, |\varphi|, \nabla \varphi) + \int_{\Omega} f(x)T_k[u - \varphi], \\ \forall \varphi \in W_0^{1,2}(\Omega) \cap L^\infty(\Omega). \end{array} \right. \tag{2.2}$$

In [1] the following proposition is proved.

Proposition 2.3. *If $\{u_n\}$ is a sequence in $\mathcal{T}_0^{1,2}(\Omega)$ satisfying the inequalities*

$$\|T_k(u_n)\|_{W_0^{1,2}(\Omega)}^2 \leq c_0 k, \quad k > 0,$$

for some $c_0 > 0$, then $\{u_n\}$ is bounded in $M^{\frac{N}{N-2}}(\Omega)$, $\{|\nabla u_n|\}$ is bounded in $M^{\frac{N}{N-1}}(\Omega)$, there exists a function u in $\mathcal{T}_0^{1,2}(\Omega)$ such that, up to subsequences, u_n converges to u almost everywhere in Ω , $T_k(u_n)$ converges weakly in $W_0^{1,2}(\Omega)$ to $T_k(u)$, $k > 0$ and $\|T_k(u)\|_{W_0^{1,2}(\Omega)}^2 \leq c_0 k$.

3. T-minima

3.1. Existence

Theorem 3.1. *Under assumption (2.1), if $f \in L^1(\Omega)$, there exists a T-minimum u of $J(v)$, in the sense of (2.2), such that*

$$\int_{\Omega} |\nabla T_k(u)|^2 \leq \frac{\|f\|_{L^1(\Omega)}}{\alpha} k, \quad k > 0, \tag{3.1}$$

$$\int_{B_{h,k}} |\nabla u|^2 \leq \frac{1}{\alpha} \int_{A_h} |f|, \quad h, k > 0, \tag{3.2}$$

where

$$B_{h,k} = \{x \in \Omega : h \leq |u(x)| < h + k\},$$

$$A_h = \{x \in \Omega : h \leq |u(x)|\}.$$

Moreover, $u \in M^{\frac{N}{N-2}}(\Omega)$ and $\nabla u \in M^{\frac{N}{N-1}}(\Omega)$.

Proof. Consider a sequence $\{f_n\}$ of smooth functions converging to f in $L^1(\Omega)$ and such that $\|f_n\|_{L^1(\Omega)} \leq \|f\|_{L^1(\Omega)}$ (e.g. $f_n = T_n(f)$) and consider the minima $u_n \in W_0^{1,2}(\Omega)$ of

$$\int_{\Omega} j(x, |v|, \nabla v) - \int_{\Omega} f_n v .$$

The minima exist by the De Giorgi semicontinuity theorem (see [10], [9]) and belong to $L^\infty(\Omega)$, for any $n \in \mathbb{N}$. The definition of minimum implies that, for any $k > 0$,

$$\begin{cases} \int_{\Omega} j(x, |u_n|, \nabla u_n) - \int_{\Omega} f_n u_n \\ \leq \int_{\Omega} j(x, |u_n - T_k(u_n)|, \nabla [u_n - T_k(u_n)]) - \int_{\Omega} f_n [u_n - T_k(u_n)], \end{cases}$$

that gives

$$\alpha \int_{\Omega} |\nabla T_k(u_n)|^2 \leq \int_{\Omega} f_n(x) T_k(u) \leq k \|f\|_{L^1(\Omega)} .$$

Thus the sequence $\{T_k(u_n)\}$ (for any $k > 0$ fixed) is bounded in $W_0^{1,2}(\Omega)$. Then, thanks to Proposition 2.3, there exist a measurable function u and a subsequence $\{n_j\}$ such that $T_k(u) \in W_0^{1,2}(\Omega)$, $T_k(u_{n_j})$ converges weakly to $T_k(u)$ in $W_0^{1,2}(\Omega)$ and u_{n_j} converges to u almost everywhere in Ω . Use again the minimality of $\{u_{n_j}\}$, with $\varphi \in W_0^{1,2}(\Omega) \cap L^\infty(\Omega)$:

$$\left\{ \begin{aligned} & \int_{\Omega} j(x, |u_{n_j}|, \nabla u_{n_j}) - \int_{\Omega} f_{n_j} u_{n_j} \\ & \leq \int_{\Omega} j(x, |u_{n_j} - T_k(u_{n_j} - \varphi)|, \nabla [u_{n_j} - T_k(u_{n_j} - \varphi)]) \\ & - \int_{\Omega} f_{n_j} [u_{n_j} - T_k(u_{n_j} - \varphi)]. \end{aligned} \right.$$

It is convenient to observe that on the subset $\{x \in \Omega : u_n(x) - \varphi(x) > k\}$, $k > 2\|\varphi\|_{L^\infty(\Omega)}$, we have $|u_n| \geq |u_n - k|$.

On the subset $\{x : u_n(x) - \varphi(x) < -k\}$, $k > 2\|\varphi\|_{L^\infty(\Omega)}$, we have $|u_n| \geq |u_n + k|$. Hence the previous inequality becomes

$$\left\{ \begin{aligned} & \int_{\{ |u_{n_j} - \varphi| \leq k \}} j(x, |u_{n_j}|, \nabla u_{n_j}) \\ & + \int_{\{ |u_{n_j} - \varphi| > k \}} (j(x, |u_{n_j}|, \nabla u_{n_j}) - j(x, |u_{n_j} - k|, \nabla u_{n_j})) \\ & + \int_{\{ |u_{n_j} - \varphi| < -k \}} (j(x, |u_{n_j}|, \nabla u_{n_j}) - j(x, |u_{n_j} + k|, \nabla u_{n_j})) \\ & \leq \int_{\{ |u_{n_j} - \varphi| \leq k \}} j(x, |\varphi|, \nabla \varphi) \\ & + \int_{\Omega} f_{n_j} T_k[u_{n_j} - \varphi], \end{aligned} \right.$$

that implies (as j is increasing with respect to s and $j(x, s, 0) = 0$)

$$\int_{\{ |u_{n_j} - \varphi| \leq k \}} j(x, |u_{n_j}|, \nabla u_{n_j}) \leq \int_{\{ |u_{n_j} - \varphi| \leq k \}} j(x, |\varphi|, \nabla \varphi) + \int_{\Omega} f_{n_j} T_k(u_{n_j} - \varphi) .$$

Now recall that, for almost every k in \mathbb{R}^+ ,

$$\chi_{\{x \in \Omega : |u_{n_j} - \varphi| \leq k\}} \rightarrow \chi_{\{x \in \Omega : |u - \varphi| \leq k\}},$$

strongly in $L^\rho(\Omega)$, for every $1 \leq \rho < +\infty$. Here χ_E denotes the characteristic function of a set $E \subseteq \Omega$. Remark that $\{x \in \Omega : |u_{n_j}(x) - \varphi(x)| \leq k\} \subset \{x \in \Omega : |u_{n_j}(x)| \leq k + \|\varphi\|_{L^\infty(\Omega)} := M\}$, so the first integral in the previous inequality is equal to

$$\int_{\Omega} j(x, |T_M(u_{n_j})|, \nabla T_M(u_{n_j})).$$

Then, thanks to weak- $W_0^{1,2}(\Omega)$ lower semicontinuity (see [10], [9]) of

$$\int_{\Omega} j(x, |v|, \nabla v) \chi_{\{x: |v(x) - \varphi(x)| \leq k\}},$$

the $L^1(\Omega)$ convergence of f_{n_j} , the weak*- $L^\infty(\Omega)$ convergence of $T_k(u_{n_j} - \varphi)$, it is possible to pass to the limit in (2.9) and to prove the existence of a T-minimum u . The choice of $\varphi = 0$ in (2.2) gives (3.1). Moreover, taking $\varphi = T_h(u)$ in (2.2), (3.2) easily follows. The facts that $u \in M^{\frac{N}{N-2}}(\Omega)$ and $\nabla u \in M^{\frac{N}{N-1}}(\Omega)$ are consequences of (3.1), proved in [1]. \square

3.2. Euler–Lagrange equation

Theorem 3.2. *Let $f \in L^1(\Omega)$. Assume (2.1) and*

$$|j_\xi(x, s, \xi)| \leq \gamma|\xi|, \quad |j_s(x, s, \xi)| \leq \gamma|\xi|^2. \tag{3.3}$$

If u is a T-minimum of J , then u is the entropy solution of the boundary value problem

$$\begin{cases} u \in T_0^{1,2}(\Omega) : \\ \int_{\Omega} j_\xi(x, |u|, \nabla u) \nabla T_k[u - v] + \int_{\{|u-v| \leq k\}} j_s(x, |u|, \nabla u) \frac{u}{|u|} (u - v) \\ \leq \int_{\Omega} f T_k[u - v], \\ \forall v \in W_0^{1,2}(\Omega) \cap L^\infty(\Omega). \end{cases} \tag{3.4}$$

Proof. We have

$$\begin{aligned} \int_{\substack{\{|u-\varphi| \leq k\} \\ \{|u| \leq h\}}} j(x, |u|, \nabla u) &\leq \int_{\substack{\{|u-\varphi| \leq k\} \\ \{|u| \leq h\}}} j(x, |u|, \nabla u) + \int_{\substack{\{|u-\varphi| \leq k\} \\ \{h < |u|\}}} j(x, |u|, \nabla u) \\ &= \int_{\{|u-\varphi| \leq k\}} j(x, |u|, \nabla u). \end{aligned}$$

Then, in the definition of T-minimum, take $\varphi = T_h(u) + tT_k(v - T_h(u))$, with $0 < t < 1$ and $v \in W_0^{1,2}(\Omega) \cap L^\infty(\Omega)$. We thus have

$$\begin{aligned} & \int_{\{|u-\varphi|\leq k\}} j(x, |u|, \nabla u) \leq \int_{\substack{\{|u-\varphi|\leq k\} \cap \{|u-v|\leq k\} \\ \{|u|\leq h\}}} j(x, |u+t(v-u)|, \nabla u + t\nabla(v-u)) \\ & + \int_{\substack{\{|u-\varphi|\leq k\} \cap \{k < |u-v|\} \\ \{|u|\leq h\}}} j(x, |u|, \nabla u) \\ & + \int_{\substack{\{|u-\varphi|\leq k\} \cap \{|v-T_h(u)|\leq k\} \\ \{h < |u|\}}} j(x, |tv|, t\nabla v) + \int_{\Omega} fT_k[u - T_h(u) - tT_k(v - T_h(u))]. \end{aligned}$$

We put together the first and the third integral and we remark that, as $t \in (0, 1)$, it results $\{x : |u(x)| \leq h\} \subset \{x : |u(x) - \varphi(x)| \leq k\}$. Then we have

$$\begin{aligned} & \int_{\{|u-v|\leq k\} \cap \{|u|\leq h\}} j(x, |u|, \nabla u) \leq \int_{\{|u-v|\leq k\} \cap \{|u|\leq h\}} j(x, |u+t(v-u)|, \nabla u + t\nabla(v-u)) \\ & + \int_{\substack{\{|u-\varphi|\leq k\} \cap \{<|v-T_h(u)|\leq k\} \\ \{h < |u|\}}} j(x, |tv|, t\nabla v) + \int_{\Omega} fT_k[u - T_h(u) - tT_k(v - T_h(u))]. \end{aligned}$$

The facts that $T_j(u) \in W_0^{1,2}(\Omega)$, for any $j > 0$, and $v \in W_0^{1,2}(\Omega)$ allow us to pass to the limit (thanks to Lebesgue Theorem) for $h \rightarrow \infty$. Moreover, since $0 < t < 1$, $T_k[tT_k(v - u)] = tT_k(v - u)$, we obtain

$$- \int_{\{|u-v|\leq k\}} \frac{j(x, |u+t(v-u)|, \nabla u + t\nabla(v-u)) - j(x, |u|, \nabla u)}{t} \leq \int_{\Omega} fT_k[u - v].$$

That is,

$$\begin{aligned} & - \int_{\{|u-v|\leq k\}} \frac{j(x, |u+t(v-u)|, \nabla u + t\nabla(v-u)) - j(x, |u+t(v-u)|, \nabla u)}{t} \\ & - \int_{\{|u-v|\leq k\}} \frac{j(x, |u+t(v-u)|, \nabla u) - j(x, |u|, \nabla u)}{t} \leq \int_{\Omega} fT_k[u - v]. \end{aligned}$$

As usual, the conclusion follows taking the limit for $t \rightarrow 0^+$.

$$\begin{aligned} & \int_{\{|u-v|\leq k\}} j_\xi(x, |u|, \nabla u) \nabla(u-v) + \int_{\{|u-v|\leq k\}} j_s(x, |u|, \nabla u) \frac{u}{|u|} (u-v) \\ & \leq \int_{\Omega} fT_k[u - v], \end{aligned}$$

that is,

$$\int_{\Omega} j_{\xi}(x, |u|, \nabla u) \nabla T_k[u-v] + \int_{\{|u-v| \leq k\}} j_s(x, |u|, \nabla u) \frac{u}{|u|} (u-v) \leq \int_{\Omega} f T_k[u-v]. \quad (3.5)$$

□

4. Functionals with lower order terms

Let $p = 2$, $g(s)$ be a convex C^1 -function,

$$f \in L^m(\Omega), \quad 1 \leq m < \frac{2N}{N+2}, \quad (4.1)$$

and again $\{f_n\}$ be a sequence of bounded functions converging to f in $L^m(\Omega)$, with $|f_n| \leq |f|$. Define

$$I(v) = \int_{\Omega} j(x, |v|, \nabla v) + \int_{\Omega} g(v) - \int_{\Omega} f v,$$

where on j we assume again (2.1). The results proved in Theorem 3.1 about the sequence $\{u_n\}$ of the minima in $W_0^{1,2}(\Omega)$ of

$$\int_{\Omega} j(x, |v|, \nabla v) + \int_{\Omega} g(v) - \int_{\Omega} f_n v.$$

still hold.

Moreover we shall prove the following lemma.

Lemma 4.1. *For every $k > 0$ and $n \in \mathbb{N}$, it results*

$$\int_{\{x \in \Omega: |u_n(x)| \geq k\}} g'(u_n) \frac{u_n}{|u_n|} \leq \int_{\{x \in \Omega: |u_n(x)| \geq k\}} |f|. \quad (4.2)$$

Proof. The minimality of u_n implies that

$$\int_{\Omega} j(x, |u_n|, \nabla u_n) + \int_{\Omega} g(u_n) - \int_{\Omega} f_n u_n \leq \int_{\Omega} j(x, |v|, \nabla v) + \int_{\Omega} g(v) - \int_{\Omega} f_n v. \quad (4.3)$$

Recall that u_n belongs to $L^\infty(\Omega)$, for any $n \in \mathbb{N}$, and take $v = u_n + t(w - u_n)$, where $w \in W_0^{1,2}(\Omega) \cap L^\infty(\Omega)$ and $0 < t < 1$. We use the convexity of j with respect to ξ and we obtain

$$\begin{aligned}
& \int_{\Omega} j(x, |u_n|, \nabla u_n) + \int_{\Omega} g(u_n) \\
& \leq \int_{\Omega} j(x, |u_n + t(w - u_n)|, \nabla [u_n + t(w - u_n)]) + \int_{\Omega} g(u_n + t(w - u_n)) \\
& \quad - t \int_{\Omega} f_n(w - u_n) \\
& \leq (1 - t) \int_{\Omega} j(x, |u_n + t(w - u_n)|, \nabla u_n) + t \int_{\Omega} j(x, |u_n + t(w - u_n)|, \nabla w) \\
& \quad + \int_{\Omega} g(u_n + t(w - u_n)) - t \int_{\Omega} f_n(w - u_n).
\end{aligned}$$

So, $t > 0$ implies

$$\begin{aligned}
& \int_{\Omega} \frac{j(x, |u_n|, \nabla u_n) - j(x, |u_n + t(w - u_n)|, \nabla u_n)}{t} \\
& + \int_{\Omega} j(x, |u_n + t(w - u_n)|, \nabla u_n) + \int_{\Omega} \frac{g(u_n) - g(u_n + t(w - u_n))}{t} \\
& \leq \int_{\Omega} j(x, |u_n + t(w - u_n)|, \nabla w) - \int_{\Omega} f_n(w - u_n).
\end{aligned}$$

The limit as $t \rightarrow 0$ yields

$$\begin{aligned}
& \int_{\Omega} j_s(x, |u_n|, \nabla u_n) \frac{u_n}{|u_n|} (u_n - w) + \int_{\Omega} j(x, |u_n|, \nabla u_n) + \int_{\Omega} g'(u_n) (u_n - w) \\
& \leq \int_{\Omega} j(x, |u_n|, \nabla w) + \int_{\Omega} f_n(u_n - w).
\end{aligned}$$

Recall the Stampacchia theorem: on the subset $\{x \in \Omega : v(x) = 0\}$, it results $\nabla v(x) = 0$. Now the choice $w = u_n - T_{\epsilon}[G_k(u_n)]$ gives

$$\begin{aligned}
& \int_{\Omega} j_s(x, |u_n|, \nabla u_n) \frac{u_n}{|u_n|} T_{\epsilon}[G_k(u_n)] + \int_{\Omega} j(x, |u_n|, \nabla u_n) + \int_{\Omega} g'(u_n) T_{\epsilon}[G_k(u_n)] \\
& \leq \int_{\Omega} j(x, |u_n|, \nabla u_n - \nabla T_{\epsilon}[G_k(u_n)]) + \int_{\{|u_n(x)| \geq k\}} f_n T_{\epsilon}[G_k(u_n)].
\end{aligned}$$

Let $\epsilon > 0$. Since

$$\int_{\Omega} j(x, |u_n|, \nabla u_n - \nabla T_{\epsilon}[G_k(u_n)]) \leq \int_{\Omega} j(x, |u_n|, \nabla u_n)$$

we have

$$\left\{ \begin{array}{l} \int_{\{x \in \Omega: |u_n(x)| \geq k\}} j_s(x, |u_n|, \nabla u_n) \frac{u_n}{|u_n|} \frac{T_\epsilon[G_k(u_n)]}{\epsilon} \\ + \int_{\{x \in \Omega: |u_n(x)| \geq k\}} \frac{g'(u_n) T_\epsilon[G_k(u_n)]}{\epsilon} \leq \int_{\{|u_n(x)| \geq k\}} |f|. \end{array} \right.$$

The limit as $\epsilon \rightarrow 0$ yields

$$\int_{\{x \in \Omega: |u_n(x)| \geq k\}} j_s(x, |u_n|, \nabla u_n) + \int_{\{x \in \Omega: |u_n(x)| \geq k\}} g'(u_n) \frac{u_n}{|u_n|} \leq \int_{\{|u_n(x)| \geq k\}} |f|.$$

In particular, we have

$$\int_{\{x \in \Omega: |u_n(x)| \geq k\}} j_s(x, |u_n|, \nabla u_n) \leq \int_{\{|u_n(x)| \geq k\}} |f| \tag{4.4}$$

and

$$\int_{\{x \in \Omega: |u_n(x)| \geq k\}} g'(u_n) \frac{u_n}{|u_n|} \leq \int_{\{|u_n(x)| \geq k\}} |f|. \quad \square$$

Corollary 4.2. *If $m = 1$ and $g(t) = \frac{|t|^{r+1}}{r+1}$, $r \geq 1$, then we have*

$$\|u_n\|_r \leq \|f\|_1. \tag{4.5}$$

Proposition 4.3. *If $m > 1$ and $g(t) = \frac{|t|^{r+1}}{r+1}$, $r \geq 1$, then we have*

$$\|u_n\|_{rm} \leq C_1 \|f\|_1 + C_1 \|f\|_m. \tag{4.6}$$

Proof. The proof follows the ideas of [4], [7]. The inequality (4.2) and $g(t) = \frac{|t|^{r+1}}{r+1}$ result in

$$\int_{\{x \in \Omega: |u_n(x)| \geq k\}} |u_n|^r \leq \int_{\{x \in \Omega: |u_n(x)| \geq k\}} |f|. \tag{4.7}$$

If $m > 1$, the previous estimate implies (recall that any u_n is bounded, so that, for any $n \in \mathbb{N}$, there are only finitely many terms non zero), with $\nu = \frac{r}{m^r-1}$,

$$\sum_{k=0}^{k=\infty} (k+1)^{\nu-1} \sum_{h=k}^{h=\infty} \int_{\{h \leq |u_n(x)| < h+1\}} |u_n|^r \leq \sum_{k=0}^{k=\infty} (k+1)^{\nu-1} \sum_{h=k}^{h=\infty} \int_{\{h \leq |u_n(x)| < h+1\}} |f|.$$

We change order, thanks to positivity of the terms, and we obtain

$$\sum_{h=0}^{k=\infty} \int_{\{h \leq |u_n(x)| < h+1\}} |u_n|^r \sum_{k=0}^{k=h} (k+1)^{\nu-1} \leq \sum_{h=0}^{h=\infty} \int_{\{h \leq |u_n(x)| < h+1\}} |f| \sum_{k=0}^{k=h} (k+1)^{\nu-1}.$$

Note that g convex, $g(0) = g'(0) = 0$ gives

$$\sum_{i=0}^{i=R} g'(i) \leq g(R+1) \leq \sum_{i=0}^{i=R+1} g'(i).$$

Thus we have

$$\begin{aligned} \sum_{h=0}^{k=\infty} \int_{\{h \leq |u_n(x)| < h+1\}} |u_n|^r \frac{h^\nu}{\nu} &\leq \sum_{h=0}^{h=\infty} \int_{\{h \leq |u_n(x)| < h+1\}} |f| \frac{(h+2)^\nu}{\nu} \\ \sum_{h=0}^{k=\infty} \int_{\{h \leq |u_n(x)| < h+1\}} |u_n|^r (h+1)^\nu &\leq \sum_{h=0}^{h=\infty} \int_{\{h \leq |u_n(x)| < h+1\}} |f| (|u_n(x)| + 2)^\nu \\ &= \int_{\Omega} |f| (|u_n(x)| + 2)^\nu \end{aligned}$$

So we can conclude that

$$\begin{aligned} \int_{\Omega} |u_n|^{rm} &\leq 2^{\nu-1} [2^\nu \|f\|_1 + \|f\|_m \left(\int_{\Omega} |u_n|^{rm} \right)^{\frac{1}{m}}] \\ &\leq 2^{2\nu-1} \|f\|_1 + 2^{\nu-1} \left(\frac{\epsilon^m \|f\|_m^m}{m} + \frac{\int_{\Omega} |u_n|^{rm}}{m' \epsilon^{m'}} \right). \end{aligned}$$

□

Corollary 4.4. *If $m = 1$ and $g(t) = \frac{|t|^{r+1}}{r+1}$, $r > \frac{N}{N-2}$, we can combine Corollary 4.2 and a result of [6] in order to prove that the T -minima u belong to $W_0^{1,q}(\Omega)$, $q < \frac{2r}{1+r}$.*

Corollary 4.5. *If $1 < m < \frac{2N}{N-2}$ and $g(t) = \frac{|t|^{r+1}}{r+1}$, $\frac{1}{m} \frac{N}{N-2} < r < \frac{1}{m-1}$, we can combine Corollary 4.2 and a result of [3] and [6] in order to prove that the T -minima u belong to $W_0^{1,q}(\Omega)$, $q < \frac{2rm}{1+rm}$. If $r \geq \frac{1}{m-1}$, the T -minima u belong to $W_0^{1,2}(\Omega)$.*

Sketch of the proof. We start from (3.2) and we use the same technique of previous lemma (recall that any u_n is bounded, so that, for any $n \in \mathbb{N}$, there are only finitely many terms non zero).

$$\sum_{h=0}^{h=\infty} (h+1)^{r(m-1)-1} \int_{B_{h,1}} |\nabla u_n|^2 \leq \frac{1}{\alpha} \sum_{h=0}^{h=\infty} (h+1)^{r(m-1)-1} \int_{A_h} |f| \quad (h, k > 0),$$

$$\int_{\Omega} |u_n|^{r(m-1)-1} |\nabla u_n|^2 \leq C_1 \|f\|_1 + C_1 \|f\|_m \|u_n\|_{pm}^{r(m-1)}$$

□

References

- [1] P. Bénilan, L. Boccardo, T. Gallouet, R. Gariepy, M. Pierre, J.L. Vazquez, An L^1 theory of existence and uniqueness of solutions of nonlinear elliptic equations. *Annali Sc. Norm. Sup. Pisa* **22** (1995), 241–273.
- [2] L. Boccardo, T-minima: An approach to minimization problems in L^1 . *Contributi dedicati alla memoria di Ennio De Giorgi. Ricerche di Matematica* **49** (2000), 135–154.
- [3] L. Boccardo, T. Gallouet, Nonlinear elliptic and parabolic equations involving measure data. *J. Funct. Anal.* **87** (1989), 149–169.
- [4] L. Boccardo, T. Gallouet, Nonlinear elliptic equations with right hand side measures. *Comm. P.D.E.* **17** (1992), 641–655.
- [5] L. Boccardo, T. Gallouet, Strongly nonlinear elliptic equations having natural growth terms and L^1 data. *Nonlinear Anal TMA* **19** (1992), 573–579.
- [6] L. Boccardo, T. Gallouet, J.L. Vazquez, Nonlinear elliptic equations in \mathbf{R}^N without growth restrictions on the data. *J. Diff. Eq.* **105** (1993), 334–363.
- [7] L. Boccardo, D. Giachetti, L^s -regularity of solutions of some nonlinear elliptic problems, preprint
- [8] R. Cirmi, Regularity of the solutions to nonlinear elliptic equations with a lower-order term. *Nonlinear Anal.* **25** (1995), 569–580.
- [9] B. Dacorogna, Direct methods in the calculus of variations, Applied Mathematical Sciences 78, Springer-Verlag, Berlin–New York, 1989.
- [10] E. De Giorgi, Teoremi di semicontinuità nel calcolo delle variazioni, Lecture notes, Istituto Nazionale di Alta Matematica, Roma, 1968.
- [11] O. Ladyženskaya, N. Ural'ceva, Linear and quasilinear elliptic equations, Academic Press, New York, 1968.
- [12] C. Leone, T-minima: some remarks about existence, uniqueness and stability results. *Asymptotic Anal.* **29** (2002), 273–282.
- [13] L. Orsina, Weak minima for some functionals and elliptic equations with measure data. *C. R. Acad. Sci. Paris* **322** (1996), 1151–1156.
- [14] A. Porretta: Remarks on existence or loss of minima of infinite energy.

Lucio Boccardo
Dipartimento di Matematica
Università di Roma 1
Piazza A. Moro 2
00185 Roma
Italy
e-mail: boccardo@mat.uniroma1.it

A Note on Heteroclinic Solutions of Mountain Pass Type for a Class of Nonlinear Elliptic PDE's

Sergey Bolotin and Paul H. Rabinowitz

To Djairo de Figueiredo on the occasion of his 70th birthday

1. Introduction

Consider the partial differential equation

$$(PDE) \quad -\Delta u + F_u(x, u) = 0, \quad x \in \mathbb{R}^n,$$

where the function $F \in C^2(\mathbb{R}^n \times \mathbb{R}, \mathbb{R})$ is 1-periodic in all arguments. Hence $F \in C^2(\mathbb{T}^{n+1}, \mathbb{R})$, where $\mathbb{T}^{n+1} = \mathbb{R}^{n+1}/\mathbb{Z}^{n+1}$ is a torus. Equation (PDE) was studied by Moser [1] who initiated a codimension 1 version of the results of the Aubry–Mather theory [3, 4]. Bangert [2] further developed the work of [1]. More recently in [5]–[7] minimization arguments were used to show the existence of several kinds of homoclinic and heteroclinic solutions of (PDE). Our goal is to show that there are also associated mountain pass solutions of (PDE). We will show how to find such solutions in the simplest heteroclinic setting of [5]–[7]. A further paper will discuss more complex cases by other arguments.

To be more precise, Moser showed that (PDE) possesses an ordered set of solutions that are 1-periodic in x_1, \dots, x_n . Suppose $v_0 < w_0$ are an adjacent pair of such solutions. Bangert proved that there are solutions of (PDE) heteroclinic in x_1 from v_0 to w_0 and periodic in x_2, \dots, x_n . A minimization characterization of these heteroclinics was given in [5], and it was also shown that they are ordered. Suppose that $v_1 < w_1$ are an adjacent pair of such heteroclinics. Our main result is the existence of a heteroclinic solution, u , of (PDE) of mountain pass type with $v_1 < u < w_1$.

In §2 we prepare for the main result by recalling the variational characterization of v_0, v_1 etc. and formulate the variational problem to find u . Then in §3 the

This research was partially supported by the NSF grant #0300319 (S. Bolotin) resp. grant #MCS-8110556 (P.H. Rabinowitz).

technical results required for the existence proof are stated and the main theorem is established. Lastly in §4 the technical results of §3 are proved.

Recently we learned that de la Llave and Valdinoci have also obtained a similar result in the setting of an Allen–Cahn-model equation.

2. Some variational formulations

As was mentioned in §1, the simplest solutions of (PDE) are periodic ones. Moser found such solutions in [1] for a broader class of equations than (PDE). To obtain them in our setting, let

$$L(x, u, \nabla u) = \frac{1}{2} |\nabla u|^2 + F(x, u)$$

and set $\Gamma_0 = W^{1,2}(\mathbb{T}^n, \mathbb{R})$. Define the functional $J_0 : \Gamma_0 \rightarrow \mathbb{R}$ by

$$J_0(u) = \int_{\mathbb{T}^n} L(x, u, \nabla u) dx.$$

Then we have

Proposition 2.1 (Moser). *Let*

$$c_0 = \inf_{u \in \Gamma_0} J_0(u)$$

and set

$$\mathcal{M}_0 = \{u \in \Gamma_0 \mid J_0(u) = c_0\}.$$

Then:

1. $\mathcal{M}_0 \neq \emptyset$;
2. $u \in \mathcal{M}_0$ is a classical solution of (PDE);
3. \mathcal{M}_0 is an ordered set, i.e. $v, w \in \mathcal{M}_0$ implies $v \equiv w$, $v < w$, or $v > w$.

To continue, suppose that \mathcal{M}_0 does not foliate \mathbb{R}^{n+1} , i.e. \mathcal{M}_0 possesses gaps:

(*)₀ There exist adjacent $v_0 < w_0$ in \mathcal{M}_0 .

Condition (*)₀ is equivalent to saying that graphs of minimizers in \mathcal{M}_0 laminate rather than foliate \mathbb{T}^{n+1} . In [7] it was shown that this condition is a generic one. Using (*)₀, Bangert [2] showed that there exists a solution of (PDE) that is heteroclinic in x_1 from v_0 to w_0 and is periodic in x_2, \dots, x_n . He used a generalization of Proposition 2.1 from [1] and an approximation argument as his existence tool to find u . A more direct minimization argument was given in [7] and the renormalized functional introduced there will also be employed here. See also [5, 6] for a related argument.

Let $S = \mathbb{R} \times \mathbb{T}^{n-1}$, $T_i = [i, i+1] \times \mathbb{T}^{n-1}$ and set

$$\Gamma_1 = \left\{ u \in W_{\text{loc}}^{1,2}(S, \mathbb{R}) \mid v_0 \leq u \leq w_0, \right. \\ \left. \lim_{i \rightarrow -\infty} \|u - v_0\|_{L^2(T_i)} = 0, \quad \lim_{i \rightarrow \infty} \|u - w_0\|_{L^2(T_i)} = 0 \right\},$$

Γ_1 is the class of admissible functions to determine the heteroclinic solutions. The asymptotic conditions express the desired heteroclinic behavior in a weak fashion.

For $u \in \Gamma_1$, define

$$J_1(u) = \sum_{i=-\infty}^{\infty} \left(\int_{T_i} L(x, u, \nabla u) dx - c_0 \right). \tag{2.2}$$

Then in [7] it was shown that if $u \in \Gamma_1$, the formal series in (2.2) is bounded from below and either converges or diverges to $+\infty$. Moreover if $J_1(u) < \infty$, then $\|u - v_0\|_{W^{1,2}(T_i)} \rightarrow 0$ as $i \rightarrow -\infty$ and $\|u - w_0\|_{L^2(T_i)} \rightarrow 0$ as $i \rightarrow \infty$, i.e. stronger asymptotic behavior than is required by Γ_1 obtains.

Set

$$c_1 = \inf_{u \in \Gamma_1} J_1(u). \tag{2.3}$$

Let e_1, \dots, e_n be the basis in \mathbb{R}^n and let $\tau_i^k u(x) = u(x - ie_k)$. Then we have

Proposition 2.4. *Let $(*)_0$ hold and let*

$$\mathcal{M}_1 = \{u \in \Gamma_1 \mid J_1(u) = c_1\}.$$

Then:

1. $\mathcal{M}_1 \neq \emptyset$;
2. A $u \in \mathcal{M}_1$ is a solution of (PDE) with $v_0 < u < \tau_{-1}^1 u < w_0$;
3. $\|u - v_0\|_{C^2(T_i)} \rightarrow 0$ as $i \rightarrow -\infty$ and $\|u - w_0\|_{C^2(T_i)} \rightarrow 0$ as $i \rightarrow \infty$;
4. \mathcal{M}_1 is an ordered set.

Suppose that there is a gap in \mathcal{M}_1 :

$(*)_1$ There are adjacent $v_1 < w_1$ in \mathcal{M}_1 .

Our main result is the existence of a minimax solution U of (PDE) with $v_1 < U < w_1$. In [7] it was shown that $w_1 - v_1 \in W^{1,2}(S, \mathbb{R})$, where $S = \mathbb{R} \times \mathbb{T}^{n-1}$. Thus to obtain U , it is sufficient to find $u \in W^{1,2}(S, \mathbb{R})$ such that $0 < u < w_1 - v_1$ and satisfies

$$-\Delta(v_1 + u) = F(x, v_1 + u),$$

or, equivalently,

$$-\Delta u = F(x, v_1 + u) - F(x, v_1). \tag{2.5}$$

By (2.2),

$$J_1(v_1 + u) - J_1(v_1) = \int_S \left(\frac{1}{2} |\nabla u|^2 + F(x, v_1 + u) - F(x, v_1) + \nabla v_1 \cdot \nabla u \right) dx \tag{2.6}$$

(PDE) and integration by parts shows

$$\int_S \nabla v_1 \cdot \nabla u dx = - \int_S F_u(x, v_1) u dx. \tag{2.7}$$

Define

$$Q(x, z) = F(x, v_1 + z) - F(x, v_1) - F_u(x, v_1)z.$$

Then $Q \in C^1(\mathbb{T}^n \times \mathbb{R}, \mathbb{R})$ and $Q(x, 0) = 0 = Q_z(x, 0)$. Moreover if

$$M_1 = \frac{1}{2} \sup_{\mathbb{T}^{n+1}} |F_{uu}|,$$

then for $(x, z) \in \mathbb{R}^n \times \mathbb{R}$,

$$|Q(x, z)| \leq M_1 |z|^2, \quad |Q_z(x, z)| \leq 2M_1 |z|. \quad (2.8)$$

Now define

$$I(u) = \int_S \left(\frac{1}{2} |\nabla u|^2 + Q(x, u) \right) dx. \quad (2.9)$$

Then (see e.g. [8]), $I \in C^1(E, \mathbb{R})$, where $E = W^{1,2}(S, \mathbb{R})$, and any critical point of I is a weak and therefore classical solution of (2.5). In the next section, it will be shown how to find such a u with $0 < u < w_1 - v_1$. Hence $U = v_1 + u$ provides the desired solution of (PDE).

3. The existence of a minimax solution

In this section we prove our main result:

Theorem 3.1. *Suppose $(*)_0$ and $(*)_1$ are satisfied. Then there exists a solution U of (PDE) with $U = v_1 + u$, $u \in W^{1,2}(S, \mathbb{R}) \cap C^2(S, \mathbb{R})$, $0 < u < w_1 - v_1$, and u is a critical point of I .*

Observe that by (2.6) and (2.3),

$$I(u) = J_1(v_1 + u) - c_1. \quad (3.2)$$

Hence $I(0) = 0 = I(w_1 - v_1)$. Since v_1, w_1 are minimizers of J_1 on Γ_1 , 0 and $w_1 - v_1$ are minimizers of I on E . This suggests using the Mountain Pass Theorem to find a critical point of I . However I does not satisfy the Palais–Smale condition on E and even if it did, the Mountain Pass Theorem does not directly give a solution u of (2.5) with $0 < u < w_1 - v_1$.

There are various ways to bypass these difficulties. In this note, we choose one which is close to the usual mountain pass approach. Toward this end, set

$$X = \{u \in E \mid 0 \leq u \leq w_1 - v_1\}.$$

Define

$$\mathcal{H} = \{h \in C([0, 1], E) \mid h(0) = 0, h(1) = w_1 - v_1\}.$$

and set

$$b = \inf_{h \in \mathcal{H}} \max_{\theta \in [0, 1]} I(h(\theta)). \quad (3.3)$$

We will show that b is a critical value of I . The class of curves, \mathcal{H} , is larger than necessary, as the next result shows.

Set

$$\mathcal{G} = \{g \in C([0, 1], X) \mid g(0) = 0, g(1) = w_1 - v_1\}.$$

Proposition 3.4. $b = \inf_{g \in \mathcal{G}} \max_{\theta \in [0, 1]} I(h(\theta)).$

The proof of this and the following propositions will be given in §4.

Proposition 3.5. $b > 0$.

The next step in the proof of Theorem 3.1 helps replace the Palais–Smale condition in our setting. Let $\gamma, \delta \in \mathbb{R}$ and set

$$\begin{aligned} I^\delta &= \{u \in E \mid I(u) \leq \delta\}, \\ I_\gamma &= \{u \in E \mid I(u) \geq \gamma\}, \\ I_\gamma^\delta &= I_\gamma \cap I^\delta. \end{aligned}$$

Proposition 3.6. *Suppose $I'(\psi) \neq 0$ for all $\psi \in X \cap I_b^b$. Then there are constants $\beta > 0, \varepsilon > 0$ such that*

$$\|I'(\psi)\| \geq \beta \quad \text{for } \psi \in X \cap I_{b-\varepsilon}^{b+\varepsilon}. \tag{3.7}$$

The next proposition together with Proposition 3.5 will lead to the "Deformation Theorem" required to show that b is a critical value of I .

Proposition 3.8. *I' is uniformly continuous: for all $\chi \in E$ with $\|\chi\| = 1$, and $t \in \mathbb{R}$,*

$$\|I'(u + t\chi) - I'(u)\| \leq (M_1 + 1)|t|.$$

An immediate consequence of Propositions 3.6–3.8 is:

Corollary 3.9. *Let $Y = X \cap I_{b-\varepsilon}^{b+\varepsilon}$. If $u \in X$ and $\|u - Y\| \leq \beta/(2(M_1 + 1))$, then $\|I'(u)\| \geq \beta/2$.*

A standard tool in establishing the existence of critical points of a functional is a so-called Deformation Theorem. The variant of such a result that suffices for us is:

Proposition 3.10. *If $\|I'(u)\| \geq \beta/2$ in $\{u \in E \mid \|u - Y\| \leq \beta/(2(M_1 + 1))\}$, then there exists $\bar{\varepsilon} \in (0, b/2)$, $\varepsilon \in (0, \bar{\varepsilon})$, and $\eta \in C([0, 1] \times E, E)$ such that:*

1. $\eta(t, u) = u$ for all $t \in [0, 1]$ if $u \notin I_{b-\varepsilon}^{b+\varepsilon}$.
2. $I(\eta(t, u)) \leq I(u)$ for all $t \in [0, 1], u \in E$.
3. $\eta(1, I^{b+\varepsilon} \cap X) \subset I^{b-\varepsilon}$.

Now we are ready for the:

Proof of Theorem 3.1. Given Proposition 3.10, this is somewhat standard. Choose $g \in \mathcal{G}$ such that

$$\max_{\theta \in [0,1]} I(g(\theta)) < b + \varepsilon. \tag{3.11}$$

By (1) of Proposition 3.10, $\eta(t, g(0)) = \eta(t, 0) = 0$, since

$$b - \hat{\varepsilon} > b - \bar{\varepsilon} > b/2 > 0 = I(0). \tag{3.12}$$

Likewise since $I(w_1 - v_1) = 0$, $\eta(t, g(1)) = \eta(t, w_1 - v_1) = w_1 - v_1$ via (3.11). Hence $\eta(1, g) \in \mathcal{H}$ and

$$\max_{\theta \in [0,1]} I(\eta(1, g(\theta))) \geq b.$$

But by (3.12) and (3) of Proposition 3.10,

$$\max_{\theta \in [0,1]} I(\eta(1, g(\theta))) \leq b - \varepsilon,$$

contrary to the definition of b . □

4. Proof of the Propositions

This section gives the proof of the propositions used in §3.

Proof of Proposition 3.4. First observe that since $C_0^1(S, \mathbb{R})$ is dense in E , using cutoff functions as in e.g. [8] and mollification, it readily follows that

$$b = \inf_{h \in \mathcal{H}_1} \max_{\theta \in [0,1]} I(h(\theta)), \quad (4.1)$$

where

$$\mathcal{H}_1 = \{h \in \mathcal{H} \mid h(\theta) \in C_0^1(S, \mathbb{R}) \text{ for all } \theta \in [0, 1]\}.$$

Next let $h \in \mathcal{H}_1$. We will produce $g = G(h) \in \mathcal{G}$ such that for all $\theta \in [0, 1]$,

$$I(g(\theta)) \leq I(h(\theta)). \quad (4.2)$$

Then (4.1)–(4.2) immediately yield Proposition 3.4.

Thus let $h \in \mathcal{H}_1$. To obtain g from h , the minimization characterization of members of \mathcal{M}_0 and \mathcal{M}_1 will be exploited. In particular we use the fact that they are like geodesics.

Since $h \in \mathcal{H}_1$, there is a $j = j(h) \in \mathbb{N}$ such that for all $\theta \in [0, 1]$,

$$v_0 - j < v_1 + h(\theta) < v_0 + j.$$

Set $\phi_1 = \max(w_0, v_1 + h)$. Then $\phi_1 \in \Gamma_1(w_0)$, where

$$\Gamma_1(w_0) = \{u \in W_{\text{loc}}^{1,2}(S, \mathbb{R}) \mid w_0 - j \leq u \leq w_0 + j \text{ and } \|u - w_0\|_{L^2(T_i)} \rightarrow 0 \text{ as } |i| \rightarrow \infty\}.$$

Set $\psi_1 = \min(w_0, v_1 + h)$. Then

$$J_1(\phi_1) + J_1(\psi_1) = J_1(w_0) + J_1(v_1 + h) = J_1(v_1 + h). \quad (4.3)$$

In [7] it is shown that

$$\inf_{\Gamma_1(w_0)} J_1 = 0.$$

Therefore $J_1(\phi_1) \geq 0$ and

$$J_1(\psi_1) \leq J_1(v_1 + h). \quad (4.4)$$

Next let $\phi_2 = \max(v_0, \psi_1)$ and $\psi_2 = \min(v_0, \psi_1)$. Then $\psi_2 \in \Gamma_1(v_0)$ and $\phi_2 \in \Gamma_1$, so as for (4.3)–(4.4),

$$J_1(\phi_2) \leq J_1(\phi_2) + J_1(\psi_2) = J_1(v_0) + J_1(\psi_1) \leq J_1(v_1 + h). \quad (4.5)$$

At this point we have in effect replaced $v_1 + h(\theta)$ by a curve of functions lying between v_0 and w_0 . We carry out a similar process to get $v_1 + g$ lying between v_1 and w_1 . Set $\phi_3 = \max(w_1, \phi_2)$ and $\psi_3 = \min(w_1, \phi_2)$. Since $\phi_3 \in \Gamma_1$,

$$c_1 + J_1(\psi_3) \leq J_1(\phi_3) + J_1(\psi_3) = J_1(w_1) + J_1(\phi_2) = c_1 + J_1(\phi_2), \quad (4.6)$$

or

$$J_1(\psi_3) \leq J_1(\phi_2). \tag{4.7}$$

Lastly set $\phi_4 = \max(v_1, \psi_3) \in \Gamma_1$ and $\psi_4 = \min(v_1, \psi_3) \in \Gamma_1$. Then

$$c_1 + J_1(\phi_4) \leq J_1(\psi_3) + J_1(\phi_4) = J_1(v_1) + J_1(\psi_3) = c_1 + J_1(\psi_3), \tag{4.8}$$

or by (4.7), (4.8) and (4.5),

$$J_1(\phi_4) \leq J_1(\psi_3) \leq J_1(v_1 + h), \tag{4.9}$$

where $v_1 \leq \phi_4 \leq w_1$. Therefore $\phi_4 = v_1 + g(\theta)$ so

$$J_1(v_1 + g(\theta)) \leq J_1(v_1 + h(\theta)).$$

Finally note that the above construction is continuous in θ in E , so $g \in \mathcal{G}$. □

Proof of Proposition 3.5. For any $g \in \mathcal{G}_1$,

$$b \leq \max_{\theta \in [0,1]} I(g(\theta)).$$

Therefore if $b = 0$, there is a sequence $(g_k) \subset \mathcal{G}$ such that as $k \rightarrow \infty$,

$$\max_{\theta \in [0,1]} I(g_k(\theta)) \rightarrow 0. \tag{4.10}$$

Since $g_k(0) = 0$ and $g_k(1) = w_1 - v_1$, there is a $\theta_k \in (0, 1)$ such that

$$\int_{T_0} g_k(\theta_k) dx = \frac{1}{2} \int_{T_0} (w_1 - v_1) dx. \tag{4.11}$$

Now

$$0 \leq I(g_k(\theta_k)) \leq \max_{\theta \in [0,1]} I(g_k(\theta)), \tag{4.12}$$

so by (4.10) as $k \rightarrow \infty$,

$$I(g_k(\theta_k)) = J_1(v_1 + g_k(\theta_k)) - c_1 \rightarrow 0.$$

Since $v_1 + g_k(\theta_k) \in \Gamma_1$, $(v_1 + g_k(\theta_k))$ is a minimizing sequence for (2.3). An argument from [7] implies that a subsequence converges in $W_{loc}^{1,2}(S, \mathbb{R})$ to $u^* \in \mathcal{M}_1$. But by $(*)_1$, $u^* = v_1$ or w_1 . Hence

$$\int_{T_0} (v_1 + g_k(\theta_k)) dx \rightarrow \int_{T_0} v_1 dx \text{ or } \int_{T_0} w_1 dx,$$

contrary to (4.11). Thus $b > 0$. □

Proof of Proposition 3.6. If the result is false, then there is a sequence $(\varepsilon_k) \subset \mathbb{R}$, with $\varepsilon_k > 0$, and a sequence $(\psi_k) \subset X \cap I_{b-\varepsilon_k}^{b+\varepsilon_k}$ such that as $k \rightarrow \infty$, $\varepsilon_k \rightarrow 0$ and $I'(\psi_k) \rightarrow 0$. Thus for large k ,

$$b + 1 \geq I(\psi_k) = \frac{1}{2} \|\nabla \psi_k\|_{L^2(S)}^2 + \int_S Q(x, \psi_k) dx. \tag{4.13}$$

By (2.8) and (4.13),

$$\|\nabla \psi_k\|_{L^2(S)}^2 \leq b + 1 + M_1 \|\psi_k\|_{L^2(S)}^2. \tag{4.14}$$

Since $0 \leq \psi_k \leq w_1 - v_1 \leq 1$,

$$\|\psi_k\|_{L^2(S)}^2 \leq \int_S (w_1 - v_1) dx. \quad (4.15)$$

But by Proposition 2.4,

$$\begin{aligned} \int_S (w_1 - v_1) dx &\leq \int_S (v_1(x + e_1) - v_1(x)) dx \\ &= \sum_{i \in \mathbb{Z}} \int_{T_i} (v_1(x + e_1) - v_1(x)) dx = \int_{T_0} (w_0 - v_0) dx \leq 1. \end{aligned} \quad (4.16)$$

Combining (4.14)–(4.16) yields

$$\|\nabla \psi_k\|_{L^2(S)}^2 \leq b + 1 + M_1. \quad (4.17)$$

The argument of (4.15)–(4.16) further shows

$$\|\psi_k\|_{L^2(S)}^2 \leq 1. \quad (4.18)$$

Consequently (ψ_k) is bounded in E . Hence there is a $\psi^* \in X$ such that along a subsequence $\psi_k \rightarrow \psi^*$ weakly in E and strongly in $L_{\text{loc}}^2(S)$. We claim that $\psi_k \rightarrow \psi^*$ in E strongly along a subsequence. To see this, note that

$$I'(\psi_k)\zeta = \int_S (\nabla \psi_k \cdot \nabla \zeta + Q_z(x, \psi_k)\zeta) dx \rightarrow 0 \quad (4.19)$$

as $k \rightarrow \infty$ for all $\zeta \in E$. The weak convergence of ψ_k shows that as $k \rightarrow \infty$,

$$\int_S \nabla \psi_k \cdot \nabla \zeta dx \rightarrow \int_S \nabla \psi^* \cdot \nabla \zeta dx. \quad (4.20)$$

Next let $R > 0$. Let $B_R(0)$ be a ball of radius R around 0 in \mathbb{R}^n . Then

$$\int_S Q_z(x, \psi_k) dx = \int_{B_R(0)} + \int_{S \setminus B_R(0)}. \quad (4.21)$$

By the convergence of ψ_k to ψ^* in $L_{\text{loc}}^2(S)$ and (2.8), the first term on the right in (4.21) goes to 0 for any $R > 0$. To estimate the second term, by (2.8) and (4.15)–(4.16),

$$\begin{aligned} \left| \int_{S \setminus B_R(0)} Q_z(x, \psi_k)\zeta dx \right| &\leq M_1 \|\zeta\|_{L^2(S)} \|\psi_k\|_{L^2(S)} \\ &\leq M_1 \|\zeta\|_{L^2(S)} \|w_1 - v_1\|_{L^2(S \setminus B_R(0))}. \end{aligned} \quad (4.22)$$

The last term on the right in (4.22) is the tail of a convergent integral. Therefore it goes to 0 as $R \rightarrow \infty$. Combining these observations shows that for all $\zeta \in E$,

$$I'(\psi^*)\zeta = 0. \quad (4.23)$$

Now

$$(I'(\psi_k) - I'(\psi^*))\zeta = \int_S [(\nabla(\psi_k - \psi^*) \cdot \nabla \zeta + (Q_z(x, \psi_k) - Q_z(x, \psi^*))\zeta)] dx. \quad (4.24)$$

By (4.24),

$$\begin{aligned} & \|\psi_k - \psi^*\|_{W^{1,2}(S)} \\ &= \sup_{\|\zeta\|_{W^{1,2}(S)}=1} \left| \int_S [\nabla(\psi_k - \psi^*) \cdot \nabla\zeta + (Q_z(x, \psi_k) - Q_z(x, \psi^*))\zeta] dx \right| \\ &= \sup_{\|\zeta\|_{W^{1,2}(S)}=1} \left| (I'(\psi_k) - I'(\psi^*)) \cdot \zeta \right. \\ & \quad \left. - \int_S (Q_z(x, \psi_k) - Q_z(x, \psi^*))\zeta dx + \int_S (\psi_k - \psi^*)\zeta dx \right|. \end{aligned}$$

By (4.19) and arguments that led to (4.23), the right hand side tends to 0 as $k \rightarrow \infty$. Consequently $\psi_k \rightarrow \psi^*$ in E , $I(\psi_k) \rightarrow I(\psi^*) = b$ and $I'(\psi^*) = 0$ contrary to the hypothesis. Thus Proposition 3.6 is proved. \square

Proof of Proposition 3.8. Let $\zeta \in E$ with $\|\zeta\| = 1$. Then

$$\begin{aligned} |(I'(u + t\chi) - I'(u))\zeta| &= \left| \int_S [t\nabla\chi \cdot \nabla\zeta + (Q_z(x, u + t\chi) - Q_z(x, u))\zeta] dx \right| \\ &\leq |t|(\|\nabla\chi\|_{L^2(S)} + M_1\|\chi\|_{L^2(S)}) \leq |t|(M_1 + 1), \end{aligned}$$

from which the result follows. \square

Proof of Proposition 3.10. Generally to prove a result like this (see e.g. Theorem A.4 of [9]), one assumes the Palais–Smale condition. It is used to conclude that the set of critical points corresponding to b is compact and an estimate like (3.7) holds. These facts are supplanted here by Propositions 3.6 and 3.10. Therefore we may follow the remainder of the proof of Theorem A.4 in [9] to prove the proposition. \square

References

- [1] Moser, J., Minimal solutions of variational problems on a torus, *AIHP Analyse Nonlinéaire*, **3**, (1986), 229–272.
- [2] Bangert, V., On minimal laminations of the torus, *AIHP Analyse Nonlinéaire*, **6**, (1989), 95–138.
- [3] Aubry, S. and P. Y. LeDaeron, The discrete Frenkel-Kantorova model and its extensions I-Exact results for the ground states, *Physica*, **8D**, (1983), 381–422.
- [4] Mather, J. N., Existence of quasi-periodic orbits for twist homeomorphisms of the annulus, *Topology*, **21**, (1982), 457–467.
- [5] Rabinowitz, P. H. and Stredulinsky E., On some results of Moser and of Bangert, *AIHP, Analyse Nonlinéaire*, **21**, (2004), 673–688.
- [6] Rabinowitz, P. H. and Stredulinsky E., On some results of Moser and Bangert, II.
- [7] Rabinowitz, P. H. and Stredulinsky E., In progress.
- [8] Coti-Zelati, V. and Rabinowitz P. H., Homoclinic type solutions for a semilinear elliptic PDE on \mathbb{R}^n , *Comm. Pure Appl. Math.* **45**, (1992), 1217–1269.

- [9] Rabinowitz, P. H., *Minimax Methods in Critical Points Theory with Applications to Differential Equations*, *CBMS Regional Conference Series in Math.*, **65**, American Math. Soc. (1984).

Sergey Bolotin and Paul H. Rabinowitz
Department of Mathematics
University of Wisconsin–Madison
Madison, WI 53706
USA
e-mail: rabinowi@math.wisc.edu

Existence of Multiple Solutions for Quasilinear Equations via Fibering Method

Yuri Bozhkov and Enzo Mitidieri

This paper is dedicated to Djairo de Figueiredo for his friendship and insight.

Abstract. Existence and multiplicity results for a general class of radial quasilinear equations are proved using the Fibering Method introduced and developed by S. I. Pohozaev.

Mathematics Subject Classification (2000). 35J55, 35J60.

1. Introduction

In this paper we investigate the existence of positive solutions of the following quasilinear problem:

$$\left\{ \begin{array}{l} Lu := -(r^\alpha |u'(r)|^\beta u'(r))' = \lambda a(r)r^\gamma |u|^\beta u + b(r)r^\gamma |u|^{q-2}u \quad \text{in } (0, R), \\ u'(0) = u(R) = 0, \\ u > 0 \end{array} \right. \quad \text{in } (0, R). \quad (1)$$

Here $\alpha, \beta, \gamma, \lambda, R, (0 < R < \infty), q$ are real numbers and $a(r), b(r)$ are given functions.

Some problems associated to the operator L have been studied in [3]. The parameters α, β and γ are supposed to satisfy some relations which will be specified below. This class of quasilinear equations is interesting and enough general since, as one can observe, it may involve as special cases the following operators acting on radial functions defined in a ball of radius R and centre at the origin:

- 1.) Laplace operator if $\alpha = \gamma = N - 1, \beta = 0$;
 - 2.) p -Laplace operator if $\alpha = \gamma = N - 1, \beta = p - 2$;
 - 3.) k -Hessian operator if $\alpha = N - k, \gamma = N - 1, \beta = k - 1$.
- (2)

The main technique we shall use to study (1) is the so-called “Fibering Method”, introduced and developed by S. I. Pohozaev in [8, 9, 10], which provides a powerful tool for proving existence theorems, in particular for problems which obey certain kind of homogeneity. In [4] Drábek and Pohozaev have applied this method to an equation involving the p -Laplacian operator. In the study of (1) we are motivated by the observation that the critical exponents for L were found in [3], where we can also find, among other things, an inequality, which ensures that the main embeddings that we need between the natural functions spaces associated to the problem under consideration are compact. Moreover, the properties of the first eigenvalue of the corresponding eigenvalue problem with $a(r) = 1$ are also established in [3].

This paper is organized as follows. In section 2 we collect some basic facts about the operator L and state the assumptions, which we shall assume throughout the paper. In section 3 we study the corresponding eigenvalue problem with a more general a and prove the existence, simplicity and isolation of the first eigenvalue in this case. Then an adapted version of the Fibering Method to our specific problem is described in section 4. The main results for existence and multiplicity of radial solutions for (1) are proved in sections 5, 6, 7. Finally, in section 8 we comment on nonexistence results for classical solutions of quasilinear equations, in particular we establish a nonexistence result for k -Hessian equations in a general bounded smooth domain.

Acknowledgments. Yuri Bozhkov wishes to thank FAPESP, São Paulo, Brazil, and FAEP-UNICAMP for financial support.

2. Preliminaries and assumptions

In this section we present some preliminaries, notations and assumptions which will be used throughout this paper.

To begin with, let

$$\alpha > 0, \quad \beta > -1, \quad \alpha - \beta - 1 > 0, \quad \gamma > 0, \quad 0 < R < \infty. \quad (3)$$

For parameters satisfying (3) it was found in [3] that the critical exponent for (1) with $a(r) = b(r) = 1$ has the value

$$l^* = \frac{(\gamma + 1)(\beta + 2)}{\alpha - \beta - 1}. \quad (4)$$

Let

$$X_R := \left\{ u \in C^2((0, R)) \cap C^1([0, R]) \mid \int_0^R r^\alpha |u'(r)|^{\beta+2} dr < \infty, \right. \\ \left. u(R) = 0, u'(0) = 0 \right\},$$

with the norm

$$\|u\|_{X_R} := \left\{ \int_0^R r^\alpha |u'(r)|^{\beta+2} dr \right\}^{\frac{1}{\beta+2}}.$$

In this way X_R becomes a Banach space. We also define the space

$$L_\gamma^s((0, R); a) = \left\{ u \in L^s((0, R)) \mid 0 < \int_0^R a(r)|u|^{s r^\gamma} dr < \infty \right\}.$$

With this at hand, the following inequality holds:

$$\left(\int_0^R |u|^{s r^\gamma} dr \right)^{\frac{1}{s}} \leq c \left(\int_0^R r^\alpha |u'|^{\beta+2} dr \right)^{\frac{1}{\beta+2}} \quad (5)$$

where $s < l^*$ —the critical exponent given by (4). See [3]. The latter inequality implies that the space X_R is compactly embedded in $L_\gamma^s((0, R); a)$ provided $s < l^*$ if $\alpha - \beta - 1 > 0$. See [3] for more details.

Now we shall state the assumptions. Let $\lambda, q \in \mathbb{R}$. In addition to (3) we shall suppose that

$$1 < \beta + 2 < q < l^*, \quad (6)$$

where l^* is defined in (4).

The functions $a(r)$ and $b(r)$ are supposed to be bounded in $(0, R)$:

$$a, b \in L^\infty((0, R)), \quad (7)$$

and

$$a(r) = a_1(r) - a_2(r), \text{ where } a_1, a_2 \geq 0, \quad a_1(r) \not\equiv 0. \quad (8)$$

We claim that (6) and (7) imply that

$$\int_0^R a(r)|u|^{\beta+2} r^\gamma dr,$$

and

$$\int_0^R b(r)|u|^q r^\gamma dr,$$

are finite for $u \in X_R$. Indeed, by (5) and $\beta + 2 < l^*$ we have

$$\left| \int_0^R a(r)|u|^{\beta+2} r^\gamma dr \right| \leq \|a\|_{L^\infty((0, R))} \|u\|_{L_\gamma^{\beta+2}((0, R); 1)}^{\beta+2} \leq c \|u\|_{X_R}^{\beta+2} < \infty,$$

and by (6) it follows that

$$\left| \int_0^R b(r)|u|^q r^\gamma dr \right| \leq \|b\|_{L^\infty((0, R))} \|u\|_{L_\gamma^q((0, R); 1)}^q \leq c \|u\|_{X_R}^q < \infty.$$

This proves the claim.

Now we can define the following functionals on X_R :

$$f_1(u) = \int_0^R a(r)|u|^{\beta+2} r^\gamma dr, \quad (9)$$

and

$$f_2(u) = \int_0^R b(r)|u|^q r^\gamma dr. \tag{10}$$

It is standard to check that f_1 and f_2 are weakly lower continuous.

We shall also suppose that

$$b^+(r) \not\equiv 0, \tag{11}$$

and

$$\int_0^R b(r)|u_1(r)|^q r^\gamma dx < 0, \tag{12}$$

where $u_1(r)$ is the positive eigenfunction associated to the operator L (see Theorem 1 in the next section).

Definition. We say that $u \in X_R$ is a weak solution of (1) if

$$\int_0^R r^\alpha |u'|^\beta v' dr = \lambda \int_0^R a(r)|u|^\beta u v r^\gamma dr + \int_0^R b(r)|u|^{q-2} u v r^\gamma dr, \tag{13}$$

for all $v \in X_R$.

3. The eigenvalue problem for L

In this section we consider the eigenvalue equation

$$\begin{cases} -(r^\alpha |u'(r)|^\beta u'(r))' = \lambda a(r)r^\gamma |u|^\beta u & \text{in } (0, R), \\ u'(0) = u(R) = 0, \end{cases} \tag{14}$$

where $a \in L^\infty((0, R))$ satisfies (8), in a weak sense, that is,

$$\begin{cases} \int_0^R r^\alpha |u'(r)|^\beta u' v' dr = \lambda \int_0^R a(r)|u|^\beta u v r^\gamma dr, \\ u'(0) = u(R) = 0 \end{cases}$$

for any $v \in X_R$. The problem (14) is closely related to (1). Moreover, since the aim of this paper is to apply the Fiberning Method [8, 9, 10] to the problem (1), we need the following result, which ensures the simplicity and the isolation of the first eigenvalue λ_1 of the operator L .

Theorem 1. *There exists a number $\lambda_1 > 0$ such that*

$$\lambda_1 = \inf \frac{\|u\|_{X_R}^{\beta+2}}{\int_0^R a(r)|u|^{\beta+2} r^\gamma dr},$$

where the infimum is taken over $u \in X_R$ such that $\int_0^R a(r)|u|^{\beta+2} r^\gamma dr > 0$, and u satisfies the condition (8) above. Moreover,

- (i) there exists a positive function $u_1 \in X_R$ which is weak solution of (14) with $\lambda = \lambda_1$;
- (ii) λ_1 is simple, in the sense that any two eigenfunctions, corresponding to λ_1 , differ by a positive constant multiplier;
- (iii) λ_1 is isolated, which means that there are no eigenvalues less than λ_1 and no eigenvalues in the interval $(\lambda_1, \lambda_1 + \delta)$ for some $\delta > 0$ sufficiently small.

Proof. (i) By inequality (5) we have

$$0 < \int_0^R a(r)|u|^{\beta+2}r^\gamma dr \leq \|a\|_{L^\infty((0,R))} \int_0^R |u|^{\beta+2}r^\gamma dr \leq C\|a\|_{L^\infty((0,R))}\|u\|_{X_R}$$

since $\beta + 2 < l^*$ and $a \in L^\infty$. Therefore the considered infimum exists.

Let $E(u) := \|u\|_{X_R}^{\beta+2}$ and denote by M the manifold defined by

$$M = \left\{ u \in X_R \mid \int_0^R a(r)|u|^{\beta+2}r^\gamma dr = 1 \right\}.$$

Restricting E to M we shall use the method of Lagrange multipliers to obtain a weak solution. By (3) and (5) it follows that X_R is compactly embedded in $L_s((0, R); a)$ for any $s < l^*$. Therefore M is weakly closed in X_R . The functional E is coercive with respect to X_R . Using the definition of E and (5) one can verify that E is a weakly lower semi-continuous functional. Then by standard variational arguments it follows that E attains its infimum at a point $u^* \in M$.

Since $E \in C^1(X_R)$ an easy calculation gives

$$E'(u)v = (\beta + 2) \int_0^R r^\alpha |u'(r)|^\beta u'v' dr$$

where $E'(u)v$ is the Gâteaux derivative of E at $u \in X_R$ in the direction of v . Denote

$$H(u) = \int_0^R a(r)|u|^{\beta+2}r^\gamma dr - 1.$$

Then

$$H'(u)v = (\beta + 2) \int_0^R a(r)|u|^\beta uv r^\gamma dr$$

and in particular for $u = v$:

$$H'(u)u = (\beta + 2) \int_0^R a(r)|u|^{\beta+2}r^\gamma dr = \beta + 2 > 0$$

for $u \in M$.

Now we look for a Lagrange multiplier $\lambda \in \mathbb{R}$ such that

$$E'(u^*)v - \lambda H'(u^*)v = (\beta + 2) \int_0^R r^\alpha |u^*(r)|^\beta u^*v' dr$$

$$-\lambda(\beta + 2) \int_0^R a(r)|u^*|^\beta u^*v r^\gamma dr = 0.$$

Let $v = u^*$. Then

$$0 < (\beta + 2) \int_0^R r^\alpha |u^{*'}(r)|^{\beta+2} dr = \lambda(\beta + 2) \int_0^R a(r) |u^*|^{\beta+2} r^\gamma dr = \lambda(\beta + 2).$$

Thus $\lambda > 0$ and

$$(\beta + 2) \int_0^R r^\alpha |u^{*'}(r)|^\beta u^* v' dr = \lambda(\beta + 2) \int_0^R a(r) |u^*|^\beta u^* v r^\gamma dr.$$

Therefore u^* is a weak solution of the eigenvalue problem (14). Moreover, by the arguments in [3] it follows that u^* does not vanish in $[0, R)$ and hence we can choose one $u_1 = cu^* > 0$.

(ii) We shall prove the simplicity of λ_1 . Let u and v be two weak eigenfunctions, that is,

$$\begin{aligned} \int_0^R r^\alpha |u'|^\beta u' w' dr &= \lambda \int_0^R r^\gamma a(r) |u|^\beta u w dr, \\ \int_0^R r^\alpha |v'|^\beta v' w' dr &= \lambda \int_0^R r^\gamma a(r) |v|^\beta v w dr, \\ u(R) = u'(0) &= v(R) = v'(0) = 0, \end{aligned}$$

for any w such that $w(R) = w'(0) = 0$ and $\int_0^R r^\gamma |w'|^{\beta+2} dr < \infty$. Set $u_\varepsilon = u + \varepsilon$ and $v_\varepsilon = v + \varepsilon$. Then substituting $w = u_\varepsilon - v_\varepsilon^{\beta+2} u_\varepsilon^{-\beta-1}$ in the first equation above and $w = v_\varepsilon - u_\varepsilon^{\beta+2} v_\varepsilon^{-\beta-1}$ in the second, we get that

$$\begin{aligned} \lambda_1 \int_0^R r^\gamma a(r) \left(\frac{|u|^{\beta+1}}{|u_\varepsilon|^{\beta+1}} - \frac{|v|^{\beta+1}}{|v_\varepsilon|^{\beta+1}} \right) (|u_\varepsilon|^{\beta+2} - |v_\varepsilon|^{\beta+2}) dr \\ = \int_0^R r^\gamma \left(\left[1 + (\beta + 1) \left(\frac{v_\varepsilon}{u_\varepsilon} \right)^{\beta+2} \right] |u'_\varepsilon|^{\beta+2} + \left[1 + (\beta + 1) \left(\frac{u_\varepsilon}{v_\varepsilon} \right)^{\beta+2} \right] |v'_\varepsilon|^{\beta+2} \right) dr \\ - (\beta + 2) \int_0^R r^\alpha \left(\left[\frac{v_\varepsilon}{u_\varepsilon} \right]^{\beta+1} |u'_\varepsilon|^\beta u'_\varepsilon v'_\varepsilon + \left[\frac{u_\varepsilon}{v_\varepsilon} \right]^{\beta+1} |v'_\varepsilon|^\beta v'_\varepsilon u'_\varepsilon \right) dr. \end{aligned}$$

Denote $z_\varepsilon = \log |u_\varepsilon|$ and $w_\varepsilon = \log |v_\varepsilon|$. With this notation, the last equality can be written in the following way:

$$\begin{aligned} \lambda_1 \int_0^R r^\gamma a(r) \left(\frac{|u|^{\beta+1}}{|u_\varepsilon|^{\beta+1}} - \frac{|v|^{\beta+1}}{|v_\varepsilon|^\beta} \right) (|u_\varepsilon|^{\beta+2} - |v_\varepsilon|^{\beta+2}) dr \\ = \int_0^R r^\alpha ((|u_\varepsilon|^{\beta+2} - |v_\varepsilon|^{\beta+2}) (|z'_\varepsilon|^{\beta+2} - |w'_\varepsilon|^{\beta+2})) dr \\ - (\beta + 2) \int_0^R r^\alpha (|v_\varepsilon|^{\beta+2} |z'_\varepsilon|^\beta z'_\varepsilon (w'_\varepsilon - z'_\varepsilon) + |u_\varepsilon|^{\beta+2} |w'_\varepsilon|^\beta w'_\varepsilon (z'_\varepsilon - w'_\varepsilon)) dr. \end{aligned}$$

In the inequality ([6], p.163, (4.3)),

$$|w_2|^{\beta+2} \geq |w_1|^{\beta+2} + (\beta + 2) |w_1|^\beta w_1 (w_2 - w_1) + \frac{|w_2 - w_1|^{\beta+2}}{2^{\beta+1} - 1},$$

we choose $w_1 = w'_\varepsilon$ and $w_2 = z'_\varepsilon$. Therefore

$$\begin{aligned} & |u_\varepsilon|^{\beta+2}(|z'_\varepsilon|^{\beta+2} - |w'_\varepsilon|^{\beta+2}) - (\beta + 2)|u_\varepsilon|^{\beta+2}|w'_\varepsilon|^\beta w'_\varepsilon(z'_\varepsilon - w'_\varepsilon) \\ & \geq \frac{1}{2^{\beta+1} - 1} \frac{|u_\varepsilon v'_\varepsilon - v_\varepsilon u'_\varepsilon|^{\beta+2}}{|v_\varepsilon|^{\beta+2}} \end{aligned}$$

and similarly

$$\begin{aligned} & |v_\varepsilon|^{\beta+2}(|w'_\varepsilon|^{\beta+2} - |z'_\varepsilon|^{\beta+2}) - (\beta + 2)|v_\varepsilon|^{\beta+2}|z'_\varepsilon|^\beta z'_\varepsilon(w'_\varepsilon - z'_\varepsilon) \\ & \geq \frac{1}{2^{\beta+1} - 1} \frac{|u_\varepsilon v'_\varepsilon - v_\varepsilon u'_\varepsilon|^{\beta+2}}{|u_\varepsilon|^{\beta+2}}. \end{aligned}$$

Integrating the last two inequalities and combining with the relations above we finally obtain

$$\begin{aligned} 0 & \leq \frac{1}{2^{\beta+1} - 1} \int_0^R r^\alpha \left(\frac{1}{|u_\varepsilon|^{\beta+2}} + \frac{1}{|v_\varepsilon|^{\beta+2}} \right) |u_\varepsilon v'_\varepsilon - v_\varepsilon u'_\varepsilon|^{\beta+2} dr \\ & \leq \lambda_1 \int_0^R r^\gamma a(r) \left(\frac{|u|^{\beta+1}}{|u_\varepsilon|^{\beta+1}} - \frac{|v|^{\beta+1}}{|v_\varepsilon|^{\beta+1}} \right) (|u_\varepsilon|^{\beta+2} - |v_\varepsilon|^{\beta+2}) dr. \end{aligned}$$

The latter integral tends to zero when $\varepsilon \rightarrow 0$. Hence and by Fatou's lemma we conclude that $wv' = vu'$ which implies that $v = lu$ for some $l \in \mathbb{R}$.

(iii) Let $v \in X_R$ be an eigenfunction corresponding to eigenvalue λ . By the definition of λ_1 it follows that

$$\lambda_1 \int_0^R a(r)|v|^{\beta+2} r^\gamma dr \leq \int_0^R r^\alpha |v'|^{\beta+2} dr = \lambda \int_0^R a(r)|v|^{\beta+2} r^\gamma dr.$$

Hence $\lambda \geq \lambda_1$, that is, λ_1 is isolated from below.

We normalize v :

$$\int_0^R r^\alpha |v'|^{\beta+2} dr = 1.$$

Let $u > 0$ be the eigenfunction associated to λ_1 and

$$\int_0^R r^\alpha |u'|^{\beta+2} dr = 1.$$

Following [1] consider

$$I(u, v) = \int_0^R r^\alpha |u'|^\beta u'(u - v^{\beta+2}/u^{\beta+1})' dr + \int_0^R r^\alpha |v'|^\beta v'(v - u^{\beta+2}/v^{\beta+1})' dr.$$

Using an argument, similar to that in [1] (or to that in the proof of (ii)), it can be proved that $I(w_1, w_2) \geq 0$ for any $w_i, i = 1, 2$ such that $\int_0^R r^\alpha |w'_i|^{\beta+2} dr < \infty$ and $w_i/w_j \in L^\infty((0, R))$, $i, j = 1, 2$. By the normalization and the fact that u and v are eigenfunctions with eigenvalues λ_1 and λ respectively, we obtain

$$0 \leq I(u, v) = \int_0^R r^\gamma a(r)(|u|^{\beta+2} - |v|^{\beta+2}) dr = -(\lambda_1 - \lambda)^2 / (\lambda_1 \lambda) < 0$$

if $\lambda_1 \neq \lambda$. This contradiction implies that $\lambda = \lambda_1$ and $v = lu$. □

4. The Fibering Method

Now we shall present the cornerstone of the Fibering Method [8, 9, 10] adapted to the problem (1). For this purpose we consider the following functional:

$$J_\lambda(u) := \frac{1}{\beta+2} \int_0^R r^\alpha |u'(r)|^{\beta+2} dr - \frac{\lambda}{\beta+2} \int_0^R a(r) |u|^{\beta+2} r^\gamma dr - \frac{1}{q} \int_0^R b(r) |u|^q r^\gamma dr. \quad (15)$$

Clearly $J_\lambda \in C^1(X_R)$. Critical points of J_λ are then weak solutions of the problem (1).

Further, following the main point of [8, 9, 10], for $u \in X_R$ we set

$$u(x) = tz(x), \quad (16)$$

where $t \neq 0$ is a real number and $z \in X_R$. Substituting (16) into (15) we obtain

$$J_\lambda(tz) = \frac{|t|^{\beta+2}}{\beta+2} \int_0^R r^\alpha |z'(r)|^{\beta+2} dr - \frac{\lambda |t|^{\beta+2}}{\beta+2} \int_0^R a(r) |z|^{\beta+2} r^\gamma dr - \frac{|t|^q}{q} \int_0^R b(r) |z|^q r^\gamma dr. \quad (17)$$

If $u \in X_R$ is a critical point of J_λ then

$$\frac{\partial J_\lambda}{\partial t}(tz) = 0,$$

which is equivalent to

$$|t|^{\beta} t \int_0^R r^\alpha |z'(r)|^{\beta+2} dr - \lambda |t|^{\beta} t \int_0^R a(r) |z|^{\beta+2} r^\gamma dr - |t|^{q-2} t \int_0^R b(r) |z|^q r^\gamma dr = 0. \quad (18)$$

Assuming that

$$\int_0^R r^\alpha |z'(r)|^{\beta+2} dr - \lambda \int_0^R a(r) |z|^{\beta+2} r^\gamma dr \neq 0$$

and

$$\int_0^R b(r) |z|^q r^\gamma dr \neq 0,$$

from (18) we get that

$$|t|^{q-\beta-2} = \frac{\int_0^R r^\alpha |z'(r)|^{\beta+2} dr - \lambda \int_0^R a(r) |z|^{\beta+2} r^\gamma dr}{\int_\Omega b(x) |z|^q dx} > 0. \quad (19)$$

In the Sections 4 and 5 we shall suppose that

$$\int_0^R r^\alpha |z'(r)|^{\beta+2} dr - \lambda \int_0^R a(r) |z|^{\beta+2} r^\gamma dr > 0, \quad \int_0^R b(r) |z|^q r^\gamma dr > 0. \quad (20)$$

In Section 6 we shall admit

$$\int_0^R r^\alpha |z'(r)|^{\beta+2} dr - \lambda \int_0^R a(r) |z|^{\beta+2} r^\gamma dr < 0, \quad \int_0^R b(r) |z|^q r^\gamma dr < 0. \quad (21)$$

Thus, in both cases (20) and (21), the function $t = t(z)$ is well defined. Now we insert into (17) the expression for $t = t(z)$, determined by (19). In this way we obtain a functional $I_\lambda(z) = J_\lambda(t(z)z)$ given by

$$I_\lambda(z) = \sigma \left(\frac{1}{\beta+2} - \frac{1}{q} \right) \frac{\left| \int_0^R r^\alpha |z'(r)|^{\beta+2} dr - \lambda \int_0^R a(r) |z|^{\beta+2} r^\gamma dr \right|^{q/(q-\beta-2)}}{\left| \int_0^R b(r) |z|^q r^\gamma dr \right|^{(\beta+2)/(q-\beta-2)}}, \quad (22)$$

where

$$\sigma = \operatorname{sgn} \left(\int_0^R b(r) |z|^q r^\gamma dr \right).$$

Therefore, provided z satisfies (20) or (21), we have

$$\frac{d}{dt} (J_\lambda(tz))|_{t=t(z)} = 0.$$

It is clear that the following lemma holds.

Lemma 1 ([4]). (i) For every $z \in X_R$ such that $\int_\Omega b(x) |z|^q dx \neq 0$ and every $p > 0$

$$I_\lambda(pz) = I_\lambda(z),$$

that is, the functional I_λ is homogeneous of degree 0.

(ii) $I'_\lambda(z)z = 0$, where $I'_\lambda(z)z$ is the Gâteaux derivative of I_λ at $z \in X_R$ in the direction of z . If z is a critical point of I_λ then $|z|$ is also a critical point.

Hence, as in [4], one can assume that the critical points of I_λ are non-negative. The next two lemmas are direct consequences of the general Fibering Method described in [8, 9, 10].

Lemma 2 ([4]). Let $z \in X_R$ be a critical point of I_λ , which satisfies (20) or (21). Then the function

$$u(r) = tz(r),$$

where $t > 0$ is determined by (19), is a critical point of J_λ .

Lemma 3 ([4]). Let us consider a constraint

$$E(z) = c = \text{const},$$

where $E : X_R \rightarrow \mathbb{R}$ is a C^1 functional. If

$$E'(z)z \neq 0 \text{ and } E(z) = c.$$

then every critical point of I_λ with the constraint $E(z) = c$ is a critical point of I_λ .

Our first aim is to prove the existence of a critical point of I_λ with an appropriate condition $E = c$ which in turn will be an actual critical point of I_λ and hence a critical point of J_λ - the weak solution of (1).

This general scheme was suggested by Drábek and Pohozaev [4]. In the next sections we shall adapt the ideas of [4] to our specific problem.

5. Existence for $\lambda \in [0, \lambda_1)$

If we look at the functional $J_\lambda(u)$ given by (15), we can observe that its first two terms form a $(\beta + 2)$ -homogeneous expression with respect to u . It is then natural to denote by E_λ the functional

$$E_\lambda(z) = \int_0^R r^\alpha |z'(r)|^{\beta+2} dr - \lambda \int_0^R a(r) |z|^{\beta+2} r^\gamma dr \tag{23}$$

and to consider it as a possible functional generating the constraint $E_\lambda(u) = c$, for which we would apply Lemma 3. Then Theorem 1 implies that $E_\lambda(z) \geq 0$ for every $z \in X_R$. We calculate easily that the Gâteaux derivative of E_λ at $z \in X_R$ in the direction of z is

$$E'(z)z = (\beta + 2)E(z).$$

Hence if

$$E_\lambda(z) = 1,$$

then $E'_\lambda(z)z = \beta + 2 > 0$ and the conditions on E_λ in Lemma 3 are satisfied. Moreover, since we are assuming $E_\lambda(z) = 1$, by (19) we can see that we are in the case (20), that is, $\int_\Omega b(x) |z|^q dx > 0$. Further, the functional $I_\lambda(z)$ (see (22)) becomes

$$I_\lambda(z) = \left(\frac{1}{\beta + 2} - \frac{1}{q} \right) \frac{1}{\left(\int_0^R b(r) |z|^q r^\gamma dr \right)^{(\beta+2)/(q-\beta-2)}}. \tag{24}$$

The main result in this section is the following

Theorem 2. *Suppose that the conditions (3), (6)–(11) hold and that, in addition, $\lambda \in [0, \lambda_1)$. Then the problem (1) has a positive weak solution $u \in X_R$.*

Proof. The formula (23) suggests that we consider an auxiliary problem of finding a minimiser z^* of

$$\sup \left\{ \int_0^R b(r) |z|^q r^\gamma dr \mid E_\lambda(z) = 1, \int_0^R b(r) |z|^q r^\gamma dr > 0 \right\} = M_\lambda > 0. \tag{25}$$

We claim that the problem (25) has a solution. Indeed, the set

$$Y_\lambda = \{z \in X_R \mid E_\lambda(z) = 1\}$$

is non-empty ($0 \leq \lambda < \lambda_1$). By Theorem 1 we have that for any $z \in Y_\lambda$:

$$\int_0^R r^\alpha |z'(r)|^{\beta+2} dr = \lambda \int_0^R a(r) |z|^{\beta+2} r^\gamma dr + 1 \leq \frac{\lambda}{\lambda_1} \int_0^R r^\alpha |z'(r)|^{\beta+2} dr + 1$$

and hence

$$\int_0^R r^\alpha |z'(r)|^{\beta+2} dr \leq \frac{\lambda_1}{\lambda_1 - \lambda}$$

since $0 \leq \lambda < \lambda_1$. Therefore a minimizing sequence z_n for (25) is bounded in X_R . Thus we can suppose that z_n converges weakly in X_R to some z^* . By (6) and (7)

$$\int_0^R b(r) |z_n|^q r^\gamma dr \rightarrow \int_0^R b(r) |z^*|^q r^\gamma dr = M_\lambda > 0.$$

In particular $z^* \not\equiv 0$ and by Lemma 1 we may assume $z^* > 0$.

The weak lower semicontinuity of $\|\cdot\|_{X_R}$, (6) and $E_\lambda(z_n) = 1$ imply that

$$\int_0^R r^\alpha |z^{*'}|^{\beta+2} dr \leq \liminf_{n \rightarrow \infty} \|z_n\|_{X_R}^{k+1}$$

and therefore

$$E_\lambda(z^*) \leq \liminf_{n \rightarrow \infty} E_\lambda(z_n) = 1.$$

If $E_\lambda(z^*) < 1$, then there exists a number $t > 1$ such that $E_\lambda(tz^*) = 1$. Set $z_1 = tz^*$. We have $z_1 \in X_\lambda$ and

$$\int_0^R b(r) |z_1|^q r^\gamma dr = t^q \int_0^R b(r) |z^*|^q r^\gamma dr = t^q M_\lambda > M_\lambda,$$

a contradiction. This contradiction shows that $E_\lambda(z^*) = 1$ and therefore $z^* \in Y_\lambda$ is a solution of (25). By Lemma 3 it is a critical point of I_λ and by Lemma 2, $u(r) = tz^*(r)$ is a critical point of J_λ . Thus $u \in X_R$ is a weak positive solution of (1). This completes the proof. \square

6. The eigenvalue case $\lambda = \lambda_1$

We consider the problem (25) with $\lambda = \lambda_1$. In this case the corresponding set Y_λ is not bounded in X_R . Therefore we have to impose an additional condition on our data. Henceforth we shall suppose that the condition (12) is fulfilled.

Theorem 3. *Suppose that the conditions (3), (6)–(12) hold and $\lambda = \lambda_1$. Then the problem (1) has a positive weak solution $u \in X_R$.*

Proof. The arguments of the proof of this theorem would be the same as those of Theorem 2 if we can prove that the problem (25) with $\lambda = \lambda_1$ has a solution.

Let z_n be a maximizing sequence such that

$$E_{\lambda_1}(z_n) = 1, \quad \int_0^R b(r) |z_n|^q r^\gamma dr = m_n \rightarrow M_{\lambda_1} > 0.$$

(The positivity of M_{λ_1} follows from (11).) If it would be unbounded we can suppose that $\|z\|_{X_R} \rightarrow \infty$. We set $w_n = z_n/\|z_n\|_{X_R}$. Obviously $\|w_n\|_{X_R} = 1$. Then

$$E_{\lambda_1}(z_n) = \|z_n\|_{X_R}^{\beta+2} \left(\|w_n\|_{X_R}^{\beta+2} - \lambda_1 \int_0^R a(r)|w_n|^{\beta+2} r^\gamma dr \right) = 1.$$

Hence

$$0 \leq \|w_n\|_{X_R}^{\beta+2} - \lambda_1 \int_0^R a(r)|w_n|^{\beta+2} r^\gamma dr = 1/\|z_n\|_{X_R}^{\beta+2}. \quad (26)$$

Therefore

$$\lim_{n \rightarrow \infty} \lambda_1 \int_0^R a(r)|w_n|^{\beta+2} r^\gamma dr = 1.$$

We may assume that w_n converges weakly in X_R to some w^* . Then

$$\int_0^R a(r)|w^*|^{\beta+2} r^\gamma dr = 1/\lambda_1,$$

which means that $w^* \neq 0$. Furthermore

$$\|w^*\|_{X_R}^{\beta+2} \leq \liminf_{n \rightarrow \infty} \|w_n\|_{X_R}^{\beta+2} = 1,$$

and from (26) we deduce that

$$0 \leq \|w^*\|_{X_R}^{\beta+2} - \lambda_1 \int_0^R a(r)|w^*|^{\beta+2} r^\gamma dr \leq 0.$$

Therefore w^* is an eigenfunction of L and by Theorem 1 there exists a number $p > 0$ such that

$$w^*(r) = pu_1(r).$$

Since

$$\int_0^R b(r)|z_n|^q r^\gamma dr = \|z_n\|_{X_R}^q \int_0^R b(r)|w_n|^q r^\gamma dr = m_n \rightarrow M_{\lambda_1} > 0,$$

we conclude that

$$\int_0^R b(r)|w^*|^q r^\gamma dr \geq 0,$$

and therefore

$$\int_0^R b(r)|u_1|^q r^\gamma dr \geq 0,$$

which contradicts (12). Hence we can assume that z_n is bounded and $\lim_{n \rightarrow \infty} z_n = z^*$ weakly in X_R . Thus

$$\int_0^R b(r)|z_n|^q r^\gamma dr \rightarrow \int_0^R b(r)|z^*|^q r^\gamma dr = M_{\lambda_1} > 0,$$

therefore $z^* \neq 0$. Furthermore

$$0 \leq \|z^*\|_{X_R}^{\beta+2} - \lambda_1 \int_0^R a(r)|z^*|^{\beta+2} r^\gamma dr \leq 1.$$

In what follows we shall verify various claims. First, if

$$0 = \|z^*\|_{X_R}^{\beta+2} - \lambda_1 \int_0^R a(r)|z^*|^{\beta+2}r^\gamma dr$$

then by Theorem 1 necessarily $z^* = pu_1$, $p > 0$, and

$$\int_0^R b(r)|z^*|^q r^\gamma dr = p^q \int_0^R b(r)|u_1|^q r^\gamma dr = M_{\lambda_1} > 0,$$

which contradicts (12). Therefore

$$0 < \|z^*\|_{X_R}^{\beta+2} - \lambda_1 \int_0^R a(r)|z^*|^{\beta+2}r^\gamma dr \leq 1.$$

Further suppose that we have strict inequalities

$$0 < \|z^*\|_{X_R}^{\beta+2} - \lambda_1 \int_0^R a(r)|z^*|^{\beta+2}r^\gamma dr < 1.$$

Then one can find a $t > 1$ such that

$$E_{\lambda_1}(tz^*) = 1$$

and

$$\begin{aligned} & \int_0^R b(r)|tz^*|^q r^\gamma dr = t^q \int_0^R b(r)|z^*|^q r^\gamma dr \\ & = t^q M_{\lambda_1} > M_{\lambda_1} = \sup \left\{ \int_0^R b(r)|z|^q r^\gamma dr \mid E_{\lambda_1}(z) = 1 \right\}, \end{aligned}$$

a contradiction. Therefore

$$\|z^*\|_{X_R}^{\beta+2} - \lambda_1 \int_0^R a(r)|z^*|^{\beta+2}r^\gamma dr = 1.$$

Hence z^* is the maximizer of the problem (25) with $\lambda = \lambda_1$ and the rest of the proof is the same as that of the Theorem 2. This completes the proof. \square

7. Existence of two distinct solutions for $\lambda > \lambda_1$

Theorem 4. *Suppose that the conditions (3), (6)–(12) hold and $\lambda > \lambda_1$. Then there exists a number $\delta > 0$ such that for $\lambda \in (\lambda_1, \lambda_1 + \delta)$ the problem (1) has two distinct positive weak solutions in X_R .*

Proof. Consider the following two variational problems:

(I) Find a maximizer $z_1 \in X_R$ of the problem

$$M_\lambda = \sup \left\{ \int_0^R b(r)|z|^q r^\gamma dr \mid E_\lambda(z) = 1 \right\}. \quad (27)$$

(II) Find a minimizer $z_2 \in X_R$ of the problem

$$m_\lambda = \inf \left\{ E_\lambda(z) \mid \int_0^R b(r)|z|^q r^\gamma dr = -1 \right\}. \tag{28}$$

The proof is divided in several steps.

Step 1. Suppose (8) and (11). Then (27) is equivalent to the problem of finding a maximizer $z_1^* \in X_R$ of

$$0 < M_\lambda^* = \sup \left\{ \int_0^R b(r)|z|^q r^\gamma dr \mid E_\lambda(z) \leq 1 \right\}. \tag{29}$$

Proof. It is obvious that any maximizer of (27) is maximizer of (29). If $z_1^* \in X_R$ is a maximizer of (29) and $E_\lambda(z_1^*) < 1$, then we can find $p > 1$ such that $E_\lambda(pz_1^*) = 1$. Then

$$\int_0^R r^\gamma b(r)|pz_1^*|^q dr = p^q \int_0^R r^\gamma b(r)|z_1^*|^q dr = p^q M_{\lambda_1} > M_{\lambda_1}$$

which is a contradiction. Therefore $E_\lambda(z_1^*) = 1$, that is, any maximizer of (29) is maximizer of (27).

Step 2. Let (3), (6)–(12) hold. Then there is a number $\delta_1 > 0$ such that for any $\lambda \in (\lambda_1, \lambda_1 + \delta_1)$ the problem (27) has a solution $z_1 \in X_R$.

Proof. From step 1, we shall deduce the existence of $\delta_1 > 0$ corresponding to the problem (29). Suppose that this is not true, that is, there exists a sequence $\delta_s \rightarrow 0$, $\delta_s > 0$, such that the problem (29) with $\lambda = \lambda^s = \lambda_1 + \delta_s$ does not have solution. Fix an integer s and consider (29) with λ^s . Denoting by z_n^s the corresponding maximizing sequence, we have

$$\|z_n^s\|_{X_R}^{\beta+2} - \lambda^s \int_0^R a(r)|z_n^s|^{\beta+2} r^\gamma dr \leq 1, \tag{30}$$

$$\lim_{n \rightarrow \infty} \int_0^R b(r)|z_n^s|^q r^\gamma dr = M_{\lambda^s}^* > 0.$$

If z_n^s would be bounded, we may assume that z_n^s converges weakly in X_R to some z_0^s when $n \rightarrow \infty$. Then by the same arguments as in Theorem 3 we can conclude that z_0^s is a solution of (29) - a contradiction. Thus we may consider z_n^s to be unbounded. Let $w_n^s = z_n^s / \|z_n^s\|_{X_R}$. Since $\|w_n^s\|_{X_R} = 1$ we may assume that $\lim_{n \rightarrow \infty} w_n^s = w_0^s$ weakly in X_R . Then

$$\int_0^R b(r)|z_n^s|^q r^\gamma dr = \|z_n^s\|_{X_R}^q \int_0^R b(r)|w_n^s|^q r^\gamma dr \rightarrow M_{\lambda^s}^* > 0,$$

therefore

$$\int_0^R r^\gamma b(r)|w_0^s|^q dr \geq 0. \tag{31}$$

By (30) we also have

$$\int_0^R r^\alpha |w_n^{s'}(r)|^{\beta+2} dr - \lambda^s \int_0^R a(r) |w_n^s|^{\beta+2} r^\gamma dr \leq 1 / \|z_n^s\|_{X_R}^{\beta+2}. \quad (32)$$

By letting $n \rightarrow \infty$ we get

$$\int_0^R r^\alpha |w_0^{s'}(r)|^{\beta+2} dr - \lambda^s \int_0^R a(r) |w_0^s|^{\beta+2} r^\gamma dr \leq 0. \quad (33)$$

From (32)

$$\lambda^s \int_0^R a(r) |w_n^s|^{\beta+2} r^\gamma dr \geq \int_0^R r^\alpha |w_n^{s'}(r)|^{\beta+2} dr - \frac{1}{\|z_n^s\|_{X_R}^{\beta+2}}.$$

By letting $n \rightarrow \infty$, we obtain

$$\lambda^s \int_0^R a(r) |w_0^s|^{\beta+2} r^\gamma dr \geq 1. \quad (34)$$

From the weak lower semicontinuity of $\|\cdot\|_{X_R}$ and $\|w_n^s\| = 1$ we get

$$\int_0^R r^\alpha |w_0^{s'}(r)|^{\beta+2} dr \leq 1.$$

This inequality allows us to suppose that w_0^s converges weakly in X_R to some w^* . Letting $s \rightarrow \infty$ in (34) we get that

$$\lambda_1 \int_0^R a(r) |w^*|^{\beta+2} r^\gamma dr \geq 1.$$

Hence $w^* \neq 0$. By the inequality (33) we obtain

$$0 \leq \int_0^R r^\alpha |w^{*'}(r)|^{\beta+2} dr - \lambda_1 \int_0^R a(r) |w^*|^{\beta+2} r^\gamma dr \leq 0.$$

The latter and Theorem 1 imply that $w^* = tu_1$, $t > 0$. By (31) we get that

$$\int_0^R b(r) |w^*|^q r^\gamma dr \geq 0$$

and thus

$$t^q \int_0^R b(r) |u_1|^q r^\gamma dr \geq 0,$$

a contradiction to (12).

Therefore there is a number $\delta_1 > 0$ such that the variational problem (29) has a solution $z_1 \in X_R$ for $\lambda \in (\lambda_1, \lambda_1 + \delta_1)$. By step 1 z_1 is a solution of (27).

Step 3. The set

$$X_- = \left\{ z \in X_R \mid \int_0^R b(r) |z|^q r^\gamma dr = -1 \right\}$$

is not empty and $m_\lambda < 0$ for $\lambda > \lambda_1$. (Recall that m_λ is defined in (28).)

Proof. By (12)

$$\int_0^R b(r)|u_1|^q r^\gamma dr < 0.$$

Therefore there is a $t > 0$ such that

$$\int_0^R b(r)|tu_1|^q r^\gamma dr = t^q \int_0^R b(r)|u_1|^q r^\gamma dr = -1$$

and hence $tu_1 \in X_-$.

Since $\lambda > \lambda_1$ we have

$$\begin{aligned} E_\lambda(tu_1) &= t^{\beta+2} \left(\int_0^R r^\alpha |u_1'|^{\beta+2} dr - \lambda \int_0^R a(r)|u_1|^{\beta+2} r^\gamma dr \right) \\ &= t^{\beta+2} (\lambda_1 - \lambda) \int_0^R a(r)|u_1|^{\beta+2} r^\gamma dr < 0. \end{aligned}$$

This inequality implies $m_\lambda < 0$.

Step 4. Assume (3), (6)–(12). Then there is a number $\delta_2 > 0$ such that for any $\lambda \in (\lambda_1, \lambda_1 + \delta_2)$ the problem (28) has a solution $z_2 \in X_R$ such that $E_\lambda(z_2) < 0$.

Proof. The proof is by contradiction and it is analogous to that in step 2.

Assume that the opposite assertion holds. Then there is a sequence $\delta_s \rightarrow 0$, $\delta_s > 0$, such that the problem (28) with $\lambda = \lambda^s = \lambda_1 + \delta_s$ does not have solutions. Fix an integer s and consider (28) with λ_s . Denote by z_n^s the corresponding maximizing sequence:

$$\int_0^R b(r)|z_n^s|^q r^\gamma dr = -1.$$

If z_n^s would be bounded we can obtain a contradiction as in the proof of step 2. Suppose that z_n^s is unbounded in X_R . As before, set $w_n^s = z_n^s / \|z_n^s\|_{X_R}$, $\|w_n^s\|_{X_R} = 1$. We have $\lim_{n \rightarrow \infty} w_n^s = w_0^s$ weakly in X_R . By

$$\int_0^R b(r)|z_n^s|^q r^\gamma dr = \|z_n^s\|_{X_R}^q \int_0^R b(r)|w_n^s|^q r^\gamma dr = -1$$

we conclude that

$$\int_0^R b(r)|w_0^s|^q r^\gamma dr = 0.$$

Since $E_{\lambda^s}(z_n^s) < 0$, as in step 2, we can obtain

$$\int_0^R r^\alpha |w_0^{s'}(r)|^{\beta+2} dr - \lambda^s \int_0^R a(r)|w_0^s|^{\beta+2} r^\gamma dr \leq 0,$$

$$\lambda^s \int_0^R a(r)|w_0^s|^{\beta+2} r^\gamma dr \geq 1.$$

Analogously to previous proofs we can suppose that $w_0^s \rightarrow w^*$ weakly in X_R , and letting $s \rightarrow \infty$ we get

$$\begin{aligned} \lambda_1 \int_0^R a(r) |w^*|^{\beta+2} r^\gamma dr &\geq 1, \\ 0 \leq \int_0^R r^\alpha |w^{*'}(r)|^{\beta+2} dr - \lambda_1 \int_0^R a(r) |w^*|^{\beta+2} r^\gamma dr &\leq 0, \\ \int_0^R b(r) |w^*|^q r^\gamma dr = \lim_{s \rightarrow \infty} \int_0^R b(r) |w_0^s|^q r^\gamma dr &= 0. \end{aligned}$$

These relations imply that w^* is a multiple of u_1 and therefore

$$\int_0^R b(r) |u_1|^q r^\gamma dr = 0,$$

which contradicts (12). The fact that $E_\lambda(z_2) < 0$ follows from step 3.

Step 5. Denote $\delta = \min(\delta_1, \delta_2)$, where δ_1 is given by step 2 and δ_2 - by step 4. Let $t_i > 0$, $i = 1, 2$, be the numbers determined by (19) with $z = z_i$ - the solutions obtained in steps 2 and 4 respectively. Set $u = t_1 z_1$ and $v = t_2 z_2$. Then by Lemma 3, u and v are weak solutions of (1). It is easily seen that the first weak solution u satisfies

$$\|u\|_{X_R}^{\beta+2} - \lambda \int_0^R b(r) |u|^q r^\gamma dr > 0,$$

while the second one, v , satisfies

$$\|v\|_{X_R}^{\beta+2} - \lambda \int_0^R b(r) |v|^q r^\gamma dr \leq 0.$$

Therefore u and v are distinct. This completes the proof of Theorem 4. \square

8. Nonexistence results for classical solutions

In this section we shall comment on nonexistence results for classical solutions of quasilinear equations in a general smooth bounded domain D . However, it is clear that the assumption “the considered solutions are classical” does not seem to be a natural hypothesis for this kind of problem. Indeed, the context of the paper suggests that the natural class to consider should be the class of *weak* solutions.

Our argument, which is based on a variational identity ([7]), enables only to consider classical solutions. With regard to the problem (1) a Pohozaev type identity was proved in [3]. It was used to obtain a non-existence result in the critical case $q = l^*$. In order not to increase the volume of the paper we shall not present further details here directing the interested reader to [3].

We should mention that Guedda and Veron [5] proved a Pohozaev type identity for *weak* solutions of the problem

$$\begin{cases} -\operatorname{div} (|\nabla u|^{p-2}\nabla u) &= f(u) \text{ in } D, \\ u = 0 &\text{on } \partial D, \end{cases}$$

under some suitable growth assumption on f . We claim that the argument of Guedda and Veron [5] can be adapted in order to prove a Pohozaev type identity for weak solutions of other quasilinear equations, e.g. for the following degenerate problem:

$$\begin{cases} -\operatorname{div} (|x|^\sigma |\nabla u|^{p-2}\nabla u) &= \lambda a(x)|u|^{p-2}u + b(x)|u|^{q-2}u \text{ in } D, \\ u = 0 &\text{on } \partial D, \end{cases}$$

where $\sigma \geq 0$ and $D \subset \mathbb{R}^N$ is a bounded domain containing the origin. Clearly this problem is a generalization of that considered by Drábek and Pohozaev [4] and a slight modification of the arguments in [4] will give the existence and multiplicity of the solutions in this case. We point out that the radial form of this degenerate equation is of the type (1). Problems of this kind will be treated elsewhere in a more general context.

We are confident that a Pohozaev type identity for weak solutions of quasilinear equations involving for instance k -Hessian operators still holds if the potential does not growth very fast. However, in the present paper we shall not consider this kind of generalization.

Suppose that D is strictly star-shaped with respect to the origin. This means that

$$(x, \nu) > 0 \tag{35}$$

for any point $x \in \partial D$, ν being the outer normal to ∂D at x . Suppose also that the functions $a, b \in C^1(\bar{D})$.

We are going to establish a nonexistence result of classical solutions for k -Hessian equations of the following form:

$$-S_k(\nabla^2 u) = \lambda a(r)|u|^{k-1}u + b(r)|u|^{q-2}u \text{ in } D \tag{36}$$

with the Dirichlet boundary condition

$$u = 0. \tag{37}$$

Let us recall that the k -Hessian operator S_k , $1 \leq k \leq N$, is the partial differential operator defined by

$$S_k(\nabla^2 u) = \sigma_k(\lambda(u)), \tag{38}$$

where $u \in C^2$ and $\sigma_k(\lambda(u)) = \sigma_k(\lambda_1, \dots, \lambda_N)$ is the k -th elementary symmetric function of the eigenvalues of the Hessian matrix $\nabla^2 u$, whose elements are the second derivatives of u ([2]). Observe that the radial form of equation (36) is of the type (1).

If $u \in C^3(D)$ is a solution of (36),(37) in D , then, following the arguments in [7], we obtain that

$$\begin{aligned} & \int_D \left\{ \left[-\frac{\lambda N}{k+1} - c\lambda \right] a(x) - \frac{\lambda}{k+1} (\nabla a(x), x) \right\} |u|^{k+1} dx \\ & + \int_D \left\{ \left[-\frac{N}{q} - c \right] b(x) - \frac{1}{q} (\nabla b(x), x) \right\} |u|^q dx \\ & + \left(\frac{N-2k}{k+1} + c \right) \frac{1}{k} \int_D T_{k-1}(\nabla^2 u)_{ij} u_i u_j dx \\ & = -\frac{1}{k+1} \int_{\partial D} T_{k-1}(\nabla^2 u)_{ij} u_i u_j(x, \nu) ds, \end{aligned}$$

where c is an arbitrary real number and $T_{k-1}(\nabla^2 u)_{ij}$ is the Newtonian tensor, which is a positive-definite matrix if u is any so-called admissible for S_k function ([2]). Therefore the inequalities

$$\begin{aligned} & \frac{N-2k}{k+1} + c \geq 0, \\ & \left[-\frac{\lambda N}{k+1} - c\lambda \right] a(x) - \frac{\lambda}{k+1} (\nabla a(x), x) \geq 0, \\ & \left[-\frac{N}{q} - c \right] b(x) - \frac{1}{q} (\nabla b(x), x) \geq 0 \end{aligned} \tag{39}$$

imply the following nonexistence result:

Theorem 5. *Assume that D is strictly star-shaped with respect to the origin ((35)) and $a, b \in C^1(\bar{D})$. Suppose also that for any $x \in D$ and $\alpha \in \mathbb{R}$ the inequalities (39) hold. Then (36), (37) has no nontrivial admissible solution in $C^3(D)$, provided $N > 2k$.*

References

- [1] A. Anane, Simplicité et isolation de la première valeur propre du p-Laplacien avec poids, *C.R. Acad. Sci. Paris Sér. I* **305** (1987), 725–728.
- [2] L. Caffarelli, L. Nirenberg, and J. Spruck, The Dirichlet problem for nonlinear second order elliptic equations, III: Function of the eigenvalues of the Hessian, *Acta Math.* **155** (1985), 261–301.
- [3] Ph. Clément, D.G. de Figueiredo, and E. Mitidieri, Quasilinear elliptic equations with critical exponents, *Topol. Methods in Nonlinear Anal.* **7** (1996), 133–164.
- [4] P. Drábek and S.I. Pohozaev, Positive solutions for the p-Laplacian: application of the fibering method, *Proc. Royal Soc. Edinburgh* **127A** (1997), 703–726.
- [5] M. Guedda and L. Veron, Quasilinear elliptic equations involving critical Sobolev exponents, *Nonlinear Analysis, Theory, Meth., Appl.* **13** (1989), 879–902.

- [6] P. Lundqvist, On the equation $\operatorname{div}(|\nabla u|^{p-2}\nabla u) + \lambda|u|^{p-2}u = 0$, *Proc. A.M.S.* **109** (1990), 157–164.
- [7] S.I. Pohozaev, On eigenfunctions of quasilinear elliptic problems, *Mat. Sb.* **82** (1970), 192–212.
- [8] S.I. Pohozaev, On one approach to nonlinear equations, *Dokl. Akad. Nauk* **247** (1979), 1327–1331 (in Russian); **20** (1979), 912–916 (in English).
- [9] S.I. Pohozaev, On a constructive method in calculus of variations, *Dokl. Akad. Nauk* **298** (1988), 1330–1333 (in Russian); **37** (1988), 274–277 (in English).
- [10] S.I. Pohozaev, On fibering method for the solutions of nonlinear boundary value problems, *Trudy Mat. Inst. Steklov* **192** (1990), 146–163 (in Russian).

Yuri Bozhkov

Departamento de Matemática

Instituto de Matemática, Estatística e Computação Científica – IMECC

Universidade Estadual de Campinas – UNICAMP

C.P. 6065

13083-970 Campinas, SP

Brazil

e-mail: bozhkov@ime.unicamp.br

Enzo Mitidieri

Dipartimento di Matematica e Informatica

Università degli Studi di Trieste

Via Valerio 12/1

34127 Trieste

Italy

e-mail: mitidier@units.it

Symmetry of Solutions of a Semilinear Elliptic Problem in an Annulus

Daniele Castorina and Filomena Pacella

Abstract. We consider the subcritical problem

$$(I) \begin{cases} -\Delta u = N(N-2)u^{p-\varepsilon} & \text{in } A \\ u > 0 & \text{in } A \\ u = 0 & \text{on } \partial A \end{cases}$$

where A is an annulus in \mathbb{R}^N , $N \geq 3$, $p+1 = \frac{2N}{N-2}$ is the critical Sobolev exponent and $\varepsilon > 0$ is a small parameter. We prove that solutions of (I) which concentrate at k points, $3 \leq k \leq N$, have these points all lying in the same $(k-1)$ -dimensional hyperplane Π_k passing through the origin and are symmetric with respect to any $(N-1)$ -dimensional hyperplane containing Π_k .

1. Introduction

In this paper we continue the study of the symmetry of solutions of the problem

$$\begin{cases} -\Delta u = N(N-2)u^{p-\varepsilon} & \text{in } A \\ u > 0 & \text{in } A \\ u = 0 & \text{on } \partial A \end{cases} \quad (1.1)$$

where A is an annulus centered at the origin in \mathbb{R}^N , $N \geq 3$, $p+1 = \frac{2N}{N-2}$ is the critical Sobolev exponent for the embedding of $H_0^1(A)$ into $L^{p+1}(A)$ and $\varepsilon > 0$ is a small parameter.

In [3] we analyzed the symmetry of solutions to (1.1) which concentrate at one or two points, as $\varepsilon \rightarrow 0$. Indeed it is well known that the study of (1.1) is strictly related to the limiting problem ($\varepsilon = 0$) which exhibits a lack of compactness and gives rise to solutions of (1.1) which concentrate and blow up as $\varepsilon \rightarrow 0$ ([1], [2], [6], [9], [10]). Obviously, solutions of (1.1) which blow-up at a finite number of points

cannot be radially symmetric. Nevertheless in [3] we proved that solutions that concentrate at one or two points are axially symmetric with respect to an axis passing through the origin which contains the concentration points.

In this paper we consider the case of solutions which concentrate at $k \geq 3$, $k \leq N$, points in A and prove a partial symmetry result. To be more precise, we need some notations. We say that a family of solutions $\{u_\varepsilon\}$ of (1.1) has $k \geq 1$ concentration points at $\{P_\varepsilon^1, P_\varepsilon^2, \dots, P_\varepsilon^k\} \subset A$ if the following holds:

$$P_\varepsilon^i \neq P_\varepsilon^j, i \neq j \text{ and each } P_\varepsilon^i \text{ is a strict local maximum for } u_\varepsilon \tag{1.2}$$

$$u_\varepsilon \rightarrow 0 \text{ as } \varepsilon \rightarrow 0 \text{ locally uniformly in } \Omega \setminus \{P_\varepsilon^1, P_\varepsilon^2, \dots, P_\varepsilon^k\} \tag{1.3}$$

$$u_\varepsilon(P_\varepsilon^i) \rightarrow \infty \text{ as } \varepsilon \rightarrow 0. \tag{1.4}$$

Our result is the following

Theorem 1. *Let $\{u_\varepsilon\}$ be a family of solutions to (1.1) which concentrate at k points $P_\varepsilon^j \in A$, $j = 1, \dots, k$, $k \geq 3$ and $k \leq N$. Then, for ε small, the points P_ε^j lie on the same $(k - 1)$ -dimensional hyperplane Π_k passing through the origin and u_ε is symmetric with respect to any $(N - 1)$ -dimensional hyperplane containing Π_k .*

As in [3] the proof of the above theorem is based on the procedure developed in [8] to prove the symmetry of solutions of semilinear elliptic equations in the presence of a strictly convex nonlinearity. The main idea is to evaluate the sign of the first eigenvalue of the linearized operator in the half domains determined by the symmetry hyperplanes. To carry out this procedure we also use results of [1] and [7].

The outline of the paper is the following: in Section 2 we recall some preliminary results and prove a geometrical lemma, while in Section 3 we prove Theorem 1.

2. Preliminaries

Let A be the annulus defined as $A \equiv \{x \in \mathbb{R}^N : 0 < R_1 < |x| < R_2\}$ and T_ν be the hyperplane passing through the origin defined by $T_\nu \equiv \{x \in \mathbb{R}^N : x \cdot \nu = 0\}$, ν being a direction in \mathbb{R}^N . We denote by A_ν^- and A_ν^+ the caps in A determined by T_ν : $A_\nu^- \equiv \{x \in A : x \cdot \nu < 0\}$ and $A_\nu^+ \equiv \{x \in A : x \cdot \nu > 0\}$.

In A we consider problem (1.1) and denote by L_ε the linearized operator at a solution u_ε of (1.1):

$$L_\varepsilon = -\Delta - N(N - 2)(p - \varepsilon)u_\varepsilon^{p-\varepsilon-1}. \tag{2.1}$$

Let $\lambda_1(L_\varepsilon, D)$ be the first eigenvalue of L_ε in a subdomain $D \subset A$ with zero Dirichlet boundary conditions.

In [3] the following proposition, which is a variant of a result of [8], was proved

Proposition 2. *If either $\lambda_1(L_\varepsilon, A_\nu^-)$ or $\lambda_1(L_\varepsilon, A_\nu^+)$ is non-negative and u_ε has a critical point on $T_\nu \cap A$, then u_ε is symmetric with respect to the hyperplane T_ν .*

Let us recall some results about solutions of (1.1), proved in [7] and [1].

Let $\{u_\varepsilon\}$ be a family of solutions of (1.1) with k blow up points P_ε^i , $i = 1, \dots, k$. Then we have

Proposition 3. *There exist constants $\alpha_0 > 0$ and $\alpha_{ij} > 0$, $i, j = 1, \dots, k$ such that, as $\varepsilon \rightarrow 0$,*

$$|P_\varepsilon^i - P_\varepsilon^j| > \alpha_0 \quad i \neq j \tag{2.2}$$

$$\frac{u_\varepsilon(P_\varepsilon^i)}{u_\varepsilon(P_\varepsilon^j)} \rightarrow \alpha_{ij} \text{ for any } i, j \in \{1, \dots, k\}. \tag{2.3}$$

Moreover,

$$(u_\varepsilon(P_\varepsilon^i))^\varepsilon \rightarrow 1. \tag{2.4}$$

In the sequel we will often use the classical result that for $N \geq 3$ the problem

$$\begin{cases} -\Delta u = N(N-2)u^p & \text{in } \mathbb{R}^N \\ u(0) = 1 \end{cases} \tag{2.5}$$

has a unique classical solution which is

$$U(y) = \frac{1}{(1 + |y|^2)^{\frac{N-2}{2}}}. \tag{2.6}$$

Moreover, all non trivial solutions of the linearized problem of (2.5) at the solution U , i.e.

$$-\Delta v = N(N-2)pU^{p-1}v \text{ in } \mathbb{R}^N \tag{2.7}$$

are linear combinations of the functions

$$V_0 = \frac{1 - |y|^2}{(1 + |y|^2)^{\frac{N}{2}}}, \quad V_i = \frac{\partial U}{\partial y_i}, \quad i = 1, \dots, N. \tag{2.8}$$

In particular the only non-trivial solutions of the problem

$$\begin{cases} -\Delta v = N(N-2)pU^{p-1}v & \text{in } \mathbb{R}_-^N = \{x = (x_1, \dots, x_N) \in \mathbb{R}^N : x_1 < 0\} \\ v = 0 & \text{on } \partial\mathbb{R}_-^N = \{x = (x_1, \dots, x_N) \in \mathbb{R}^N : x_1 = 0\} \end{cases} \tag{2.9}$$

are the functions $kV_1 = k\frac{\partial U}{\partial y_1}$, $k \in \mathbb{R}$.

We conclude this section with a geometrical lemma that will be used in the proof of Theorem 1.

Lemma 4. *Let $\{P_1, \dots, P_k\}$, $2 \leq k \leq N$, be k points in \mathbb{R}^N , $P_i \neq 0 \in \mathbb{R}^N$. Then:*

- (i) *If the line passing through 0 and P_1 does not contain any P_i , $i \neq 1$, then there exist two $(N-1)$ -dimensional parallel hyperplanes T and Σ with T passing through the origin 0 such that $P_1 \in T$ and $P_i \in \Sigma$, for any $i \in \{2, \dots, k\}$.*
- (ii) *If the line passing through 0 and P_1 contains some P_i 's, $i \neq 1$, then there exists a $(k-1)$ -dimensional hyperplane Π passing through the origin containing all points P_i , $i = 1, \dots, k$.*

Proof. In the case (i) let us consider the vectors $v_1 = P_1 - 0, v_2 = P_2 - P_3, \dots, v_{k-1} = P_{k-1} - P_k, v_k = P_k - 0$.

The vectors $\{v_1, \dots, v_{k-1}\}$ obviously span a $(k - 1)$ -dimensional vector space. Let us consider any $(N - 1)$ -dimensional subspace V containing $\{v_1, \dots, v_{k-1}\}$ and not containing v_k and let us define $T = V$ and $\Sigma = v_k + V$. Then the first assertion is proved.

In the case (ii) $\{v_1, \dots, v_k\}$ are linearly dependent and so they are contained in a $(k - 1)$ -dimensional hyperplane Π passing through the origin. \square

3. Proof of Theorem 1

We start by stating a lemma, whose proof will be given later

Lemma 5. *Let $\{u_\varepsilon\}$ be a family of solutions of (1.1) with k blow-up points $P_\varepsilon^i, i = 1, \dots, k, 3 \leq k \leq N$. Then, for ε small, all points $P_\varepsilon^i, i = 1, \dots, k$, lie on the same $(k - 1)$ -dimensional hyperplane Π_k passing through the origin.*

Proof of Theorem 1. The proof is similar to that of Theorem 2 of [3], we will write the details for the reader's convenience. The first part of the statement is exactly Lemma 5. Hence we only have to prove that u_ε is symmetric with respect to any hyperplane containing Π_k . For simplicity let us assume that $\Pi_k = \{x = (x_1, \dots, x_N) \in \mathbb{R}^N : x_1 = 0, \dots, x_{N-(k-1)} = 0\}$.

Let us observe that because the solutions have k blow-up points we have (see [1], [7], [10])

$$\frac{\int_A |\nabla u_\varepsilon|^2}{\left(\int_A u_\varepsilon^{p-\varepsilon+1}\right)^{\frac{2}{p-\varepsilon+1}}} \xrightarrow{\varepsilon \rightarrow 0} k^{\frac{2}{N}} S \tag{3.1}$$

where S is the best Sobolev constant for the embedding of $H_0^1(\mathbb{R}^N)$ in $L^{p+1}(\mathbb{R}^N)$.

Let us fix an $(N - 1)$ -hyperplane T containing Π_k and, for simplicity, assume that $T = \{x = (x_1, \dots, x_N) \in \mathbb{R}^N : x_1 = 0\}$, so that $A^- = \{x \in A : x_1 < 0\}$ and $A^+ = \{x \in A : x_1 > 0\}$.

Let us consider in A^- the function

$$w_\varepsilon(x) = v_\varepsilon(x) - u_\varepsilon(x), \quad x \in A^-$$

where v_ε is the reflection of u_ε , i.e. $v_\varepsilon(x_1, \dots, x_N) = u_\varepsilon(-x_1, \dots, x_N)$.

We would like to prove that $w_\varepsilon \equiv 0$ in A^- , for ε small.

Assume, by contradiction, that for a sequence $\varepsilon_n \rightarrow 0, w_{\varepsilon_n} = w_n \not\equiv 0$. Let us consider the rescaled functions around $P_n^i = P_{\varepsilon_n}^i, i = 1, \dots, k$:

$$\tilde{w}_n^i(y) \equiv \frac{1}{\beta_n^i} w_n(P_n^i + \delta_n y) \tag{3.2}$$

defined on the rescaled domains $A_{i,n}^- = \frac{A^- - P_n^i}{\delta_n}$, with $\delta_n = (u_n(P_n^1))^{\frac{1-p_n}{2}}, p_n = p - \varepsilon_n$ and $\beta_n^i = \|\tilde{w}_n^i\|_{L^{2^*}(A_{i,n}^-)}, \tilde{w}_n^i = w_n(P_n^i + \delta_n y), i = 1, \dots, k$.

Notice that, by (2.3), all functions are rescaled by the same factor δ_n . We claim that \tilde{w}_n^i converge in C_{loc}^2 to a function w satisfying

$$\begin{cases} -\Delta w = N(N-2)pU^{p-1}w & \text{in } \mathbb{R}_-^N = \{y = (y_1, \dots, y_N) \in \mathbb{R}^N : y_1 < 0\} \\ w = 0 & \text{on } \{y = (y_1, \dots, y_N) \in \mathbb{R}^N : y_1 = 0\} \\ \|w\|_{L^{2^*}} \leq 1 \end{cases} \quad (3.3)$$

where U is defined in (2.6).

Let us prove the claim for \tilde{w}_n^1 , the same proof will apply to any \tilde{w}_n^i , because of (2.3).

We have that the functions \tilde{w}_n^1 solve the following problem:

$$\begin{cases} -\Delta \tilde{w}_n^1 = c_n \tilde{w}_n^1 & \text{in } A_{1,n}^- \\ \tilde{w}_n^1 = 0 & \text{on } \partial A_{1,n}^- \end{cases} \quad (3.4)$$

where

$$\begin{aligned} c_n(y) = & N(N-2)p_n \int_0^1 \left[t \left(\frac{1}{u_n(P_n^1)} u_n(P_n^1 + \delta_n y) \right) \right. \\ & \left. + (1-t) \left(\frac{1}{u_n(P_n^1)} v_n(P_n^1 + \delta_n y) \right) \right]^{p_n-1} dt \end{aligned}$$

One can observe that the functions $\tilde{u}_n^1 = \frac{1}{u_n(P_n^1)} u_n(P_n^1 + \delta_n y)$ and $\tilde{v}_n^1 = \frac{1}{u_n(P_n^1)} v_n(P_n^1 + \delta_n y)$ which appear in the definition of $c_n(y)$ are uniformly bounded by (2.3) and hence $c_n(y)$ is uniformly bounded too. Thus c_n is locally in any L^q space (in particular $q > \frac{N}{2}$) and hence \tilde{w}_n^1 is locally uniformly bounded.

Then, by standard elliptic estimates and by the convergence in $C_{loc}^2(\mathbb{R}^N)$ of $\tilde{u}_n^1, \tilde{v}_n^1$ to the solution U of (2.5), we get the $C_{loc}^2(\mathbb{R}_-^N)$ -convergence of \tilde{w}_n^1 to a solution w of (3.3).

Let us evaluate the $L^{\frac{N}{2}}$ -norm of c_n :

$$\begin{aligned} \int_{A_{1,n}^-} |c_n(y)|^{\frac{N}{2}} dy &\leq C_N \left[\int_{A_{1,n}^-} \left| \frac{1}{u_n(P_n^1)} u_n(P_n^1 + \delta_n y) \right|^{\frac{(p_n-1)N}{2}} dy \right] \\ &+ C_N \left[\int_{A_{1,n}^-} \left| \frac{1}{u_n(P_n^1)} v_n(P_n^1 + \delta_n y) \right|^{\frac{(p_n-1)N}{2}} dy \right] \end{aligned}$$

where C_N is a constant which depends only on N .

For the first integral in the previous formula we have

$$\int_{A_{1,n}^-} \left| \frac{1}{u_n(P_n^1)} u_n(P_n^1 + \delta_n y) \right|^{\frac{(p_n-1)N}{2}} dy = \int_{A^-} |u_n(x)|^{2^* - \frac{N\varepsilon_n}{2}} dx \leq B_N$$

by (3.1) and (1.1), B_N being a constant depending only on N .

An analogous estimate holds for the second integral.

Hence the $L^{\frac{N}{2}}$ -norm of c_n is uniformly bounded and we have

$$\int_{A_{1,n}^-} |c_n(y)|^{\frac{N}{2}} dy \leq 2C_N B_N. \tag{3.5}$$

Then multiplying (3.4) by \tilde{w}_n^1 and integrating we have that

$$\begin{aligned} \int_{A_{1,n}^-} |\nabla \tilde{w}_n^1|^2 dy &= \int_{A_{1,n}^-} c_n (\tilde{w}_n^1)^2 dy \\ &\leq \left(\int_{A_{1,n}^-} |c_n|^{\frac{N}{2}} dy \right)^{\frac{2}{N}} \left(\int_{A_{1,n}^-} |\tilde{w}_n^1|^{2^*} dy \right)^{\frac{2}{2^*}} \leq (2C_N B_N)^{\frac{2}{N}} \end{aligned} \tag{3.6}$$

Then by (2.7)–(2.9) we get $w = kV_1 = k \frac{\partial U}{\partial y_1}$, $k \in \mathbb{R}$, since, by (3.6) $w \in D^{1,2}(\mathbb{R}_-^N) = \{\varphi \in L^{2^*}(\mathbb{R}_-^N) : |\nabla \varphi| \in L^2(\mathbb{R}_-^N)\}$.

Let us first assume that for one of the sequences $\{\tilde{w}_n^i\}$, say $\{\tilde{w}_n^1\}$, the limit is $w = k \frac{\partial U}{\partial y_1}$ with $k \neq 0$.

Then, since the points P_n^1 are on the reflection hyperplane T and $\nabla u_n(P_n^1) = 0$ we have that $\frac{\partial \tilde{w}_n^1}{\partial y_1}(0) = 0$. This implies that $\frac{\partial w}{\partial y_1}(0) = k \frac{\partial^2 U}{\partial y_1^2}(0) = 0$ with $k \neq 0$, which is a contradiction since for the function $U(y) = \frac{1}{(1+|y|^2)^{\frac{N-2}{2}}}$ we have $\frac{\partial^2 U}{\partial y_1^2}(0) < 0$.

So we are left with the case when all sequences \tilde{w}_n^i converge to zero in C_{loc}^2 .

Then, for any fixed R and for n sufficiently large in the domains $E_{i,n}(R) = B(0, R) \cap A_{i,n}^-$ we have the estimates

$$|\tilde{w}_n^i(y)| \leq \frac{S}{4(2C_N B_N)^2 |B(0, R)|^{\frac{2}{2^*}}}, \quad i = 1, \dots, k, \tag{3.7}$$

where $|B(0, R)|$ is the measure of the ball $B(0, R)$.

Now we focus only on the rescaling around P_n^1 and observe that the domains $E_{i,n}(R)$, $i \geq 2$, under the rescaling around P_n^1 , correspond to domains $F_{i,n}(R)$ contained in $A_{1,n}^-$ which are translations of $E_{1,n}(R)$ by the vector $\frac{P_n^i - P_n^1}{\delta_n}$ and also the functions \tilde{w}_n^i are the translation of \tilde{w}_n^1 by the same vector, indeed $\tilde{w}_n^i = \tilde{w}_n^1 \left(y + \frac{P_n^i - P_n^1}{\delta_n} \right)$. Hence from (3.7) we have

$$|\tilde{w}_n^1(y)| \leq \frac{S}{4(2C_N B_N)^2 |B(0, R)|^{\frac{2}{2^*}}} \quad \text{in } (E_{1,n}(R) \cup (\cup_{i \geq 2} F_{i,n}(R))). \tag{3.8}$$

Now let us choose R sufficiently large such that

$$\int_{B(0,R)} |U|^{2^*} > \left(\frac{4k-1}{4k} S \right)^{\frac{N}{2}} \tag{3.9}$$

where U is, as usual, the function defined in (2.6). Then, since both functions which appear in the definition of c_n converge to the function U and the function

\tilde{u}_n^1 is just the translation of the function $\tilde{u}_n^i = \frac{1}{u_n(P_n^i)}u_n(P_n^i + \delta_n y)$ by the vector $\frac{P_n^i - P_n^1}{\delta_n}$, we have by (3.9)

$$\int_{B(0,R) \cup (\cup_{i \geq 2} B(\frac{P_n^i - P_n^1}{\delta_n}, R))} |\tilde{u}_n^1|^{p_{n+1}} > \left(\frac{4k-1}{4}S\right)^{\frac{N}{2}} \tag{3.10}$$

for n sufficiently large. This implies, by (3.1),

$$\int_{A_{1,n}^- \setminus (E_{1,n}(R) \cup (\cup_{i \geq 2} F_{i,n}(R)))} |c_n|^{\frac{N}{2}} < \left(\frac{1}{4}S\right)^{\frac{N}{2}}. \tag{3.11}$$

Since the functions \tilde{w}_n^1 solve (3.4), multiplying (3.4) by \tilde{w}_n^1 and integrating we get

$$\begin{aligned} &\int_{A_{1,n}^-} |\nabla \tilde{w}_n^1|^2 dy = \int_{A_{1,n}^-} c_n (\tilde{w}_n^1)^2 dy \\ &= \int_{A_{1,n}^- \setminus (E_{1,n}(R) \cup (\cup_{i \geq 2} F_{i,n}(R)))} c_n (\tilde{w}_n^1)^2 dy + \int_{(E_{1,n}(R) \cup (\cup_{i \geq 2} F_{i,n}(R)))} c_n (\tilde{w}_n^1)^2 dy \\ &\leq \left(\int_{A_{1,n}^- \setminus (E_{1,n}(R) \cup (\cup_{i \geq 2} F_{i,n}(R)))} |c_n|^{\frac{N}{2}} dy\right)^{\frac{2}{N}} \left(\int_{A_{1,n}^- \setminus (E_{1,n}(R) \cup (\cup_{i \geq 2} F_{i,n}(R)))} |\tilde{w}_n^1|^{2^*} dy\right)^{\frac{2}{2^*}} \\ &\quad + \left(\int_{(E_{1,n}(R) \cup (\cup_{i \geq 2} F_{i,n}(R)))} |c_n|^{\frac{N}{2}} dy\right)^{\frac{2}{N}} \left(\int_{(E_{1,n}(R) \cup (\cup_{i \geq 2} F_{i,n}(R)))} |\tilde{w}_n^1|^{2^*} dy\right)^{\frac{2}{2^*}} \\ &\leq \frac{S}{2} \end{aligned}$$

because $\|\tilde{w}_n^1\|_{L^{2^*}(A_{1,n}^-)} = 1$, the $L^{\frac{N}{2}}$ -norm of c_n is uniformly bounded by (3.5), (3.11) and (3.8) hold.

On the other hand, by the Sobolev inequality, we have

$$\int_{A_{1,n}^-} |\nabla \tilde{w}_n^1|^2 dy > S$$

which gives a contradiction.

Hence the sequences \tilde{w}_n^i cannot all converge to zero, so that $w_\varepsilon \equiv 0$ for ε small, as we wanted to prove. □

Finally we prove Lemma 5.

Proof of Lemma 5. As for the proof of Theorem 1 we adapt the proof of Lemma 6 of [3] to the case of k blow-up points, $k \geq 3$. Let us consider the line r_ε connecting P_ε^1 with the origin. By the second statement of Lemma 4 if, for ε small, r_ε contains any other point $P_\varepsilon^i, i \neq 1$, then all points $P_\varepsilon^i, i = 1, \dots, k$, belong to the same $(k - 1)$ -dimensional hyperplane Π passing through the origin and hence the assertion is proved. Therefore let us assume that for a sequence $\varepsilon_n \rightarrow 0$ the line $r_n = r_{\varepsilon_n}$ does not contain any point $P_n^i = P_{\varepsilon_n}^i, i \neq 1$. Then, again by Lemma 4, we have that there exist two $(N - 1)$ -dimensional parallel hyperplanes T_n and Σ_n , with T_n

passing through the origin, such that $P_n^1 \in T_n$ and $P_n^i \in \Sigma_n$, for any $i \in \{2, \dots, k\}$. By rotating we can always assume that $T_n = T = \{x = (x_1, \dots, x_N) \in \mathbb{R}^N : x_1 = 0\}$ and $\Sigma_n = \{x = (x_1, \dots, x_N) \in \mathbb{R}^N : x_1 = \alpha_n\}$ with $\alpha_n > 0$. In this way $P_n^1 = (0, y_2^n, \dots, y_N^n)$ while $P_n^i = (\alpha_n, x_{i,2}^n, \dots, x_{i,N}^n)$ for $i = 2, \dots, k$.

As before we define $\delta_n = (u_n(P_n^1))^{\frac{1-p_n}{2}}$ where $p_n = p - \varepsilon_n$.

Claim 1 *It is not possible that*

$$\frac{\alpha_n}{\delta_n} \xrightarrow{n \rightarrow \infty} \infty. \tag{3.12}$$

Assume, by contradiction, that (3.12) holds. We claim that, for n sufficiently large,

$$\lambda_1(L_n, A^-) \geq 0 \tag{3.13}$$

where $L_n \equiv L_{\varepsilon_n}$ denotes the linearized operator and, as before, $A^- = \{x = (x_1, \dots, x_N) \in A : x_1 < 0\}$. To prove (3.13) let us take the balls $B(P_n^i, R\delta_n)$ centered at the points P_n^i , $i = 1, \dots, k$, and with radius $R\delta_n$, $R > 1$ to be fixed later.

By (3.12) and (2.3) we have that $B(P_n^i, R\delta_n)$ does not intersect A^- for $i \geq 2$ and for large n . Moreover if we take $\vartheta_0 \in [0, \frac{\pi}{2}]$ and we consider the hyperplane $T_{\vartheta_0} = \{x = (x_1, \dots, x_N) : x_1 \sin \vartheta_0 + x_N \cos \vartheta_0 = 0\}$, by (3.12), (2.3) and the fact that P_n^1 belongs to $T = T_{\frac{\pi}{2}}$ we can choose $\vartheta_{0,n} < \frac{\pi}{2}$ and close to $\frac{\pi}{2}$ such that all balls $B(P_n^i, R\delta_n)$ do not intersect the cap $A_{\vartheta_{0,n}}^- = \{x = (x_1, \dots, x_N) : x_1 \sin \vartheta_{0,n} + x_N \cos \vartheta_{0,n} < 0\}$ for n large enough.

Then, arguing as in [5] (see also [4]), it is easy to see that it is possible to choose R such that $\lambda_1(L_n, A_{\vartheta_{0,n}}^-) > 0$ for n large, because u_n concentrates only at the points P_n^i , $i = 1, \dots, k$.

Then, fixing n sufficiently large, we set

$$\tilde{\vartheta}_n \equiv \sup\{\vartheta \in [\vartheta_{0,n}, \frac{\pi}{2}] : \lambda_1(L_n, A_{\vartheta}^-) \geq 0\}.$$

We would like to prove that $\tilde{\vartheta}_n = \frac{\pi}{2}$.

If $\tilde{\vartheta}_n < \frac{\pi}{2}$ then $P_n^i \notin A_{\tilde{\vartheta}_n}^-$, $i = 1, \dots, k$, and $\lambda_1(L_n, A_{\tilde{\vartheta}_n}^-) = 0$, by the definition of $\tilde{\vartheta}_n$. Thus considering the functions

$$w_{n, \tilde{\vartheta}_n}(x) = v_{n, \tilde{\vartheta}_n}(x) - u_n(x) \text{ in } A_{\tilde{\vartheta}_n}^-$$

where $v_{n, \tilde{\vartheta}_n}$ is defined as the reflection of u_n with respect to $T_{\tilde{\vartheta}_n}^-$, we have, by the strict convexity of f , that

$$\begin{cases} L_n(w_{n, \tilde{\vartheta}_n}) \geq 0 (> 0 \text{ if } w_{n, \tilde{\vartheta}_n}(x) \neq 0) \text{ in } A_{\tilde{\vartheta}_n}^- \\ w_{n, \tilde{\vartheta}_n} \equiv 0 \text{ on } \partial A_{\tilde{\vartheta}_n}^- . \end{cases}$$

Since $\lambda_1(L_n, A_{\tilde{\vartheta}_n}^-) = 0$, by the maximum principle, we have that $w_{n, \tilde{\vartheta}_n} \geq 0$ in $A_{\tilde{\vartheta}_n}^-$ and, since $u_n(P_n^1) > u_n(x)$ for any $x \in A_{\tilde{\vartheta}_n}^-$ we have, by the strong maximum principle, that $w_{n, \tilde{\vartheta}_n} > 0$ in $A_{\tilde{\vartheta}_n}^-$.

Hence, denoting by $(P_n^1)'$ the point in $A_{\tilde{\vartheta}}^-$ which is given by the reflection of P_n^1 with respect to $T_{\tilde{\vartheta}_n}$, we have that

$$w_{n,\tilde{\vartheta}_n}(x) > \eta > 0 \quad \text{for } x \in \overline{B((P_n^1)', \delta)} \subset A_{\tilde{\vartheta}_n}^- \tag{3.14}$$

where $B((P_n^1)', \delta)$ is the ball with center in $(P_n^1)'$ and radius $\delta > 0$ suitably chosen. Thus

$$w_{n,\tilde{\vartheta}_n+\sigma}(x) > \frac{\eta}{2} > 0 \quad \text{for } x \in \overline{B((P_n^1)'', \delta)} \subset A_{\tilde{\vartheta}_n+\sigma}^- \tag{3.15}$$

for $\sigma > 0$ sufficiently small, where $(P_n^1)''$ is the reflection of P_n^1 with respect to $T_{\tilde{\vartheta}_n+\sigma}$.

On the other hand, by the monotonicity of the eigenvalues with respect to the domain, we have that $\lambda_1(L_n, A_{\tilde{\vartheta}_n}^- \setminus \overline{B((P_n^1)', \delta)}) > 0$ and hence $\lambda_1(L_n, A_{\tilde{\vartheta}_n+\sigma}^- \setminus \overline{B((P_n^1)'', \delta)}) > 0$, for σ sufficiently small. This implies, by the maximum principle and (3.15), that

$$w_{n,\tilde{\vartheta}_n+\sigma}(x) > 0 \quad \text{for } x \in A_{\tilde{\vartheta}_n+\sigma}^- \tag{3.16}$$

Since $L_n(w_{n,\tilde{\vartheta}_n+\sigma}) \geq 0$ in $A_{\tilde{\vartheta}_n+\sigma}^-$ (by the convexity of the function $u_\varepsilon^{p-\varepsilon}$), the inequality (3.16) implies that $\lambda_1(L_n, D) > 0$ in any subdomain D of $A_{\tilde{\vartheta}_n+\sigma}^-$, and so $\lambda_1(L_n, A_{\tilde{\vartheta}_n+\sigma}^-) \geq 0$ for σ positive and sufficiently small. Obviously this contradicts the definition of $\tilde{\vartheta}_n$ and proves that $\tilde{\vartheta}_n = \frac{\pi}{2}$, i.e. (3.13) holds.

So, by Proposition 2, since $P_n^1 \in T = T_{\frac{\pi}{2}}$, we get that u_n is symmetric with respect to the hyperplane T , which is not possible, since P_n^i do not belong to T , for $i = 2, \dots, k$. Hence (3.12) cannot hold.

Claim 2 *It is not possible that*

$$\frac{\alpha_n}{\delta_n} \xrightarrow{n \rightarrow \infty} l > 0. \tag{3.17}$$

Assume that (3.17) holds and, as before, denote by T the hyperplane $T = \{x = (x_1, \dots, x_N) \in \mathbb{R}^N : x_1 = 0\}$ to which P_n^1 belongs while $P_n^i \notin T$, $i \geq 2$.

We would like to prove as in Claim 1 that

$$\lambda_1(L_n, A^-) \geq 0. \tag{3.18}$$

If the points P_n^1 and all the P_n^i have the N -th coordinate of the same sign, i.e. they lie on the same side with respect to the hyperplane $\{x_N = 0\}$, then it is obvious that we can argue exactly as for the first claim and choose $\vartheta_0 \in [0, \frac{\pi}{2}]$ such that all the balls $B(P_n^i, R\delta_n)$, R as before, do not intersect the cap $A_{\vartheta_0}^-$. Then the proof is the same as before.

Hence we assume that P_n^1 and some P_n^i , $i \neq 1$, lie on different sides with respect to the hyperplane $\{x_N = 0\}$. Let us then consider $\vartheta_n \in [0, \frac{\pi}{2}]$ such that the points P_n^1 and some of the P_n^i , say P_n^2, \dots, P_n^j , $j \leq k$, have the same distance $d_n > 0$ from the hyperplane T_{ϑ_n} ,

$$T_{\vartheta_n} = \{x = (x_1, \dots, x_N) \in \mathbb{R}^N : x_1 \sin \vartheta_n + x_N \cos \vartheta_n = 0\},$$

while the other points P_n^{j+1}, \dots, P_n^k have distance bigger than d_n from T_{ϑ_n} .

Of course, because of (3.17), we have

$$\frac{d_n}{\delta_n} \xrightarrow{n \rightarrow \infty} l_1 > 0. \tag{3.19}$$

Then, choosing $R > 0$ such that $\lambda_1(L_n, D_n^R) > 0$, for n large, where $D_n^R = A \setminus [B(P_n^1, R\delta_n) \cup (\cup_{i \geq 2} B(P_n^i, R\delta_n))]$ (see [5]), either all balls $B(P_n^i, R\delta_n)$, $i = 1, \dots, k$ do not intersect the cap $A_{\vartheta_n}^-$, for n large enough, or they do. In the first case we argue as for the first claim. In the second case we observe that in each set $E_{\vartheta_n}^{n,i} = A_{\vartheta_n}^- \cap B(P_n^i, R\delta_n)$, $i = 1, \dots, k$, we have, for n large, and whenever the intersection is not empty,

$$u_n(x) \leq v_n^{\vartheta_n}(x) \quad x \in E_{\vartheta_n}^{n,i} \quad i = 1, \dots, k, \tag{3.20}$$

where $v_n^{\vartheta_n}(x) = u_n(x^{\vartheta_n})$, x^{ϑ_n} being the reflection of x with respect to $T_{\vartheta_n}^n$.

In fact if (3.20) were not true we could construct a sequence of points $x_{n_k} \in E_{\vartheta_{n_k}}^{n_k,i}$, for some $i = 1, \dots, k$, such that

$$u_{n_k}(x_{n_k}) > v_{n_k}^{\vartheta_{n_k}}(x_{n_k}). \tag{3.21}$$

Then there would exist a sequence of points $\xi_{n_k} \in E_{\vartheta_{n_k}}^{n_k,i}$ such that

$$\frac{\partial u_{n_k}}{\partial \vartheta_{n_k}}(\xi_{n_k}) < 0. \tag{3.22}$$

Thus, by rescaling u_{n_k} in the usual way around the $P_{n_k}^i$ and using (3.19) we would get a point $\xi \in (E_{\vartheta_0}^{l_1})^- = \{x = (x_1, \dots, x_N) \in \mathbb{R}^N : x_1 \sin \vartheta_0 + x_N \cos \vartheta_0 < -l_1 < 0\}$ such that $\frac{\partial U}{\partial \vartheta_0}(\xi) \leq 0$ while $\frac{\partial U}{\partial \vartheta_0} > 0$ in $(E_{\vartheta_0}^{l_1})^-$, ϑ_0 being the limit of ϑ_{n_k} . Hence (3.20) holds.

Now, arguing again as in [5] and [4], in the set $(F_{\vartheta_n}^n)^- = A_{\vartheta_n}^- \setminus (\cup_{i \geq 1} B(P_n^i, R\delta_n))$ we have that $\lambda_1(L_n, (F_{\vartheta_n}^n)^-) \geq 0$.

Hence, by (3.20), applying the maximum principle, we have that $w_{n,\vartheta_n}(x) \geq 0$ in $(F_{\vartheta_n}^n)^-$, and, again by (3.20) and the strong maximum principle

$$w_{n,\vartheta_n}(x) > 0 \quad \text{in } A_{\vartheta_n}^-. \tag{3.23}$$

As in the proof of Claim 1, this implies that $\lambda_1(L_n, A_{\vartheta_n}^-) \geq 0$.

Then, arguing again as for the first claim we get (3.18), which gives the same kind of contradiction because P_n^i , $i \geq 2$, do not belong to T .

Claim 3 *It is not possible that*

$$\frac{\alpha_n}{\delta_n} \xrightarrow{n \rightarrow \infty} 0. \tag{3.24}$$

Let us argue by contradiction and assume that (3.24) holds. As before we denote by T the hyperplane $T = \{x = (x_1, \dots, x_N) \in \mathbb{R}^N : x_1 = 0\}$. Since the points P_n^i , $i \geq 2$, are in the domain $A_n^+ = \{x = (x_1, \dots, x_N) \in A : x_1 > 0\}$, we have that the function

$$w_n(x) = v_n(x) - u_n(x), \quad x \in A_n^+$$

where v_n is the reflection of u_n , i.e. $v_n(x_1, \dots, x_N) = u_n(-x_1, x_2, \dots, x_N)$, is not identically zero.

Then, as in the proof of Theorem 1, rescaling the function w_n around P_n^1 or $P_n^i, i \geq 2$, and using (2.3) we have that the functions

$$\tilde{w}_n^i(y) \equiv \frac{1}{\beta_n^i} w_n(P_n^i + \delta_n y), i = 1, \dots, k \tag{3.25}$$

defined in the rescaled domain $A_{i,n}^+ = \frac{A^+ - P_n^i}{\delta_n}$, converge both, by (3.24) and standard elliptic estimates, in C_{loc}^2 to a function w_i satisfying (3.3) but in the half space $\mathbb{R}_+^N = \{x = (x_1, \dots, x_N) \in \mathbb{R}^N : x_1 > 0\}$. Again by (2.7)–(2.9) we have that $w_i = k_i \frac{\partial U}{\partial y_1}, k_i \in \mathbb{R}$, where U is the function defined by (2.5).

Exactly as in the proof of Theorem 1 we can exclude the case that all sequences \tilde{w}_n^i converge to zero in C_{loc}^2 . Hence for at least one of the sequences \tilde{w}_n^i we have that the limit is $w_i = k_i \frac{\partial U}{\partial y_1}$ with $k_i \neq 0$. If this happens for \tilde{w}_n^1 then, since the points P_n^1 are on the reflection hyperplane T , arguing exactly as in the proof of Theorem 1, we get a contradiction.

So we are left with the case when $\tilde{w}_n^1 \rightarrow k_1 \frac{\partial U}{\partial y_1}, k_1 = 0$ and $\tilde{w}_n^i \rightarrow k_i \frac{\partial U}{\partial y_1}$ with $k_i \neq 0$ for some $i \geq 2$ in C_{loc}^2 . For the sake of simplicity let us suppose that $i = 2$. At the points P_n^2 , obviously we have that $\frac{\partial u_n}{\partial y_1}(P_n^2) = 0$. Let us denote by \tilde{P}_n^2 the reflection of P_n^2 with respect to T . Hence, for the function \tilde{w}_n^2 we have, applying the mean value theorem,

$$\begin{aligned} \frac{\partial \tilde{w}_n^2}{\partial y_1}(0) &= \frac{\delta_n^{\frac{2}{1-p_n}}}{\beta_n^2} \left(\frac{\partial \tilde{u}_n}{\partial y_1}(0) + \frac{\partial \tilde{u}_n}{\partial y_1} \left(\frac{\tilde{P}_n^2 - P_n^2}{\delta_n} \right) \right) \\ &= \frac{\delta_n^{\frac{2}{1-p_n}}}{\beta_n^2} \left(\frac{\partial \tilde{u}_n}{\partial y_1} \left(\frac{\tilde{P}_n^2 - P_n^2}{\delta_n} \right) - \frac{\partial \tilde{u}_n}{\partial y_1}(0) \right) \\ &= - \frac{\delta_n^{\frac{2}{1-p_n}}}{\beta_n^2} \frac{\partial^2 \tilde{u}_n}{\partial y_1^2}(\xi_n) \frac{2\alpha_n}{\delta_n}, \end{aligned}$$

where $\tilde{u}_n(y) = \frac{\delta_n^{\frac{2}{1-p_n}}}{\delta_n} u_n(P_n^2 + \delta_n y)$ and ξ_n belongs to the segment joining the origin with the point $\frac{\tilde{P}_n^2 - P_n^2}{\delta_n}$ in the rescaled domain $A_{2,n}^+$.

Since $\frac{\partial \tilde{w}_n^2}{\partial y_1}(0) \rightarrow k_2 \frac{\partial^2 U}{\partial y_1^2}(0)$ and $\frac{\partial^2 \tilde{u}_n}{\partial y_1^2}(\xi_n) \rightarrow \frac{\partial^2 U}{\partial y_1^2}(0)$, with $k_2 \neq 0$ and $\frac{\partial^2 U}{\partial y_1^2}(0) < 0$ we get

$$\frac{\alpha_n \delta_n^{\frac{2}{1-p_n}}}{\beta_n^2 \delta_n} \rightarrow \gamma \neq 0. \tag{3.26}$$

Our aim is now to prove that (3.26) implies that $k_1 \neq 0$ which will give a contradiction.

Let us observe that if the function w_n does not change sign near P_n^1 , then, since $w_n \not\equiv 0$, we would get a contradiction, applying Hopf’s lemma to w_n (which solves a linear elliptic equation) at the point P_n^1 , because $\nabla u_n(P_n^1) = 0$.

Then in any ball $B(P_n^1, \alpha_n)$, α_n as in (3.24), there are points Q_n^1 such that $\frac{\partial u_n}{\partial y_1}(Q_n^1) = 0$ and $Q_n^1 \notin T$. Indeed, since w_n changes sign near P_n^1 , in any set $B(P_n^1, \alpha_n) \cap A^+$ there are points where w_n is zero, i.e. u_n coincides with the reflection v_n . This implies that there exist points Q_n^1 in $B(P_n^1, \alpha_n)$ where $\frac{\partial u_n}{\partial y_1}(Q_n^1) = 0$, and by Hopf's lemma applied to the points of the hyperplane T we have that $Q_n^1 \notin T$. Let us denote by \tilde{Q}_n^1 the reflection of Q_n^1 with respect to T .

Assume that $Q_n^1 \in A^-$ (the argument is the same if $Q_n^1 \in A^+$). Then as before we have

$$\begin{aligned} \frac{\partial \tilde{w}_n^1}{\partial y_1} \left(\frac{Q_n^1 - P_n^1}{\delta_n} \right) &= \frac{\delta_n^{\frac{2}{1-p_n}}}{\beta_n^1} \left(\frac{\partial \tilde{u}_n}{\partial y_1} \left(\frac{\tilde{Q}_n^1 - P_n^1}{\delta_n} \right) - \frac{\partial \tilde{u}_n}{\partial y_1} \left(\frac{Q_n^1 - P_n^1}{\delta_n} \right) \right) \\ &= -\frac{\delta_n^{\frac{2}{1-p_n}}}{\beta_n^1} \frac{\partial^2 \tilde{u}_n}{\partial y_1^2}(\xi_n) \frac{2\alpha_n}{\delta_n} \end{aligned}$$

where ξ_n belongs to the segment joining $\frac{\tilde{Q}_n^1 - P_n^1}{\delta_n}$ and $\frac{Q_n^1 - P_n^1}{\delta_n}$ in the rescaled domain $A_{1,n}^+$.

Since $\frac{\partial \tilde{w}_n^1}{\partial y_1} \left(\frac{\tilde{Q}_n^1 - P_n^1}{\delta_n} \right) \rightarrow k_1 \frac{\partial^2 U}{\partial y_1^2}(0)$, $\frac{\partial^2 \tilde{u}_n}{\partial y_1^2}(\xi_n) \rightarrow \frac{\partial^2 U}{\partial y_1^2}(0) < 0$ and using (3.26), we get $k_1 \neq 0$ and hence a contradiction.

So also the third claim is true and the proof of Lemma 5 is complete. □

References

- [1] A. Bahri, Y. Li and O. Rey, *On a variational problem with lack of compactness: the topological effect of critical points at infinity*, Calc. Var. P.D.E. **3** no. 1 (1995), 67–93.
- [2] H. Brezis and L.A. Peletier, *Asymptotics for elliptic equations involving critical growth*, P. D. E. and Calc. Var. Vol. 1, Progr. No.D.E.A. 1, Birkhauser Boston, MA, 1989, 149–192.
- [3] D. Castorina and F. Pacella, *Symmetry of positive solutions of an almost-critical problem in an annulus*, Calc. Var P.D.E. **23** no. 2 (2005), 125–138.
- [4] K. El Medhi and F. Pacella, *Morse index and blow-up points of solutions of some nonlinear problems*, Atti Acc. Naz. Lincei Cl. Sc. Fis. Mat. Natur. Rend. Lincei (9), Mat. Appl. **13** no. 2 (2002), 101–105.
- [5] M. Grossi and R. Molle, *On the shape of the solutions of some semilinear elliptic problems*, Comm. in Contemp. Math. **5** no. 1 (2003), 85–99.
- [6] Z. C. Han, *Asymptotic approach to singular solutions for nonlinear elliptic equations involving critical Sobolev exponent*, Ann. Inst. Henri Poincaré **8** no. 2 (1991), 159–174.
- [7] Y. Li, *Prescribing scalar curvature on S^N and related problems – Part I*, J. Diff. Eq. **120** (1995), 319–410.
- [8] F. Pacella, *Symmetry results for solutions of semilinear elliptic equations with convex nonlinearities*, J. Funct. Anal. **192** no. 1 (2002), 271–282.
- [9] O. Rey, *A multiplicity result for a variational problem with lack of compactness*, Nonlinear Anal., T. M. A. **13** no. 10 (1989), 1241–1249.

- [10] O. Rey, *Blow-up points of solutions to elliptic equations with limiting nonlinearities*, Diff. Int. Eqs. **4** no. 6 (1991), 1157–1167.

Daniele Castorina and Filomena Pacella
Dipartimento di Matematica
Università di Roma “La Sapienza”
P. le A. Moro 2
00185 Roma
Italy
e-mail: castorin@mat.uniroma1.it
pacella@mat.uniroma1.it

Construction of a Radial Solution to a Superlinear Dirichlet Problem that Changes Sign Exactly Once

Alfonso Castro and Jorge Cossio

Abstract. We provide a method for finding a radial solution to a superlinear Dirichlet problem in a ball that changes sign exactly once and implement it using mathematical software. As a by-product, we conclude that the least energy sign changing solution for that problem is nonradial, which has been proved using different methods in [1] and [2].

1. Introduction

In this paper we study the boundary value problem

$$\begin{cases} \Delta u + |u|^p u = 0 & \text{in } B_1(0) \subset \mathbb{R}^n \\ u = 0 & \text{on } \partial B_1(0), \end{cases} \quad (1.1)$$

where Δ is the Laplacian operator, $B_1(0)$ is the unit ball centered at the origin, and $0 < p < \frac{4}{n-2}$ if $n > 2$, $p < \infty$ if $n = 2$.

If u is a radial solution to (1.1), then u satisfies

$$\begin{cases} u'' + \frac{n-1}{r}u' + |u|^p u = 0 & (0 < r \leq 1) \\ u(1) = u'(0) = 0. \end{cases} \quad (1.2)$$

From Theorem 2 (part (c)) of [4], for each positive integer k , (1.2) has exactly one solution with k zeroes in $[0, 1]$ and $u(0) > 0$.

Here we consider the case $n = p = 2$. We provide a construction of the solution to (1.2) that has exactly two zeroes in $[0, 1]$, i. e. the radial solution that changes sign exactly once. Our construction is based on the study of the initial value problem

$$\begin{cases} v'' + \frac{1}{r}v' + v^3 = 0 & (r > 0) \\ v(0) = 1, v'(0) = 0. \end{cases} \quad (1.3)$$

From this study we conclude the following result.

Theorem 1. *If α and τ are the first and the second zeroes of the solution v to problem (1.3), then the solution to (1.1) with $p = 2$ is given by $u(x) = \tau v(\tau\|x\|)$. Moreover,*

$$\begin{cases} 3.6115 \leq \alpha \leq 3.6415, \\ -0.231514 \leq v'(\alpha) \leq -0.198982, \\ \tau \geq 9.47, \\ \alpha^2(v'(\alpha))^2 \leq \int_{\alpha}^{\tau} sv^4(s)ds. \end{cases} \quad (1.4)$$

The above estimates are obtained using exact calculations carried out using mathematical software. In the absence of this software such calculations would be out of consideration.

The details of the proof of Theorem 1 are given in Section 2. In Section 3, we combine the estimates in Theorem 1, the Pohozaev identity, and the variational characterization of the least energy sign changing solution to (1.1) given in [3] to conclude that such a solution cannot be radial (see also [2]).

2. Proof of Theorem 1

From the definition of v we see that

$$\begin{aligned} \Delta u(x) &= \tau^3 v''(\tau\|x\|) + \tau^3 \frac{v'(\tau\|x\|)}{\tau\|x\|} \\ &= -\tau^3 v^3(\tau\|x\|) \\ &= -u^3(x). \end{aligned} \quad (2.1)$$

Also, for $\|x\| = 1$, $u(x) = \tau v(\tau) = 0$. Thus u satisfies (1.1) and changes sign exactly once.

Now we estimate the solution to

$$\begin{aligned} v''(r) + \frac{1}{r}v'(r) + v^3(r) &= 0, & (r > 0) \\ v'(0) &= 0, & v(0) = 1. \end{aligned} \quad (2.2)$$

Let $E(r) \equiv (v'(r))^2/2 + (v^4(r))/4$. Since $E' \leq 0$, we see that $|v(r)| \leq 1$ for all $r \in \mathbb{R}$. Hence

$$-rv'(r) = \int_0^r sv^3(s)ds \leq \frac{r^2}{2}, \quad (2.3)$$

which implies

$$v(r) \geq 1 - \frac{r^2}{4} \equiv u_1(r) \quad \text{for all } r \geq 0. \quad (2.4)$$

In particular $v(r) \geq 0$ for all $r \in [0, 2]$. Replacing (2.4) in (2.3) we have

$$\begin{aligned}
 -v'(r) &\geq \frac{1}{r} \int_0^r s u_1^3(s) ds \\
 &= \frac{1}{2}r - \frac{3}{16}r^3 + \frac{1}{32}r^5 - \frac{1}{512}r^7 \equiv v_1(r).
 \end{aligned}
 \tag{2.5}$$

From (2.5) it follows that

$$\begin{aligned}
 v(r) &\leq 1 - \int_0^r v_1(s) ds \\
 &= 1 - \frac{1}{4}r^2 + \frac{3}{64}r^4 - \frac{1}{192}r^6 + \frac{1}{4096}r^8 \equiv u_2(r).
 \end{aligned}
 \tag{2.6}$$

Arguing again as in (2.5) we conclude that

$$\begin{aligned}
 -v'(r) &\leq \frac{1}{r} \int_0^r s u_2^3(s) ds = \frac{1}{2}r - \frac{3}{16}r^3 + \frac{7}{128}r^5 \\
 &\quad - \frac{13}{1024}r^7 + \frac{49}{20480}r^9 - \frac{73}{196608}r^{11} + \frac{523}{11010048}r^{13} \\
 &\quad - \frac{125}{25165824}r^{15} + \frac{7}{16777216}r^{17} - \frac{197}{7247757312}r^{19} \\
 &\quad + \frac{91}{70866960384}r^{21} - \frac{1}{25769803776}r^{23} \\
 &\quad + \frac{1}{1786706395136}r^{25} \equiv v_2(r).
 \end{aligned}
 \tag{2.7}$$

Integration of the latter inequality on $[0, r]$ gives

$$\begin{aligned}
 v(r) &\geq 1 - \int_0^r v_2(s) ds = 1 - \frac{1}{4}r^2 + \frac{3}{64}r^4 \\
 &\quad - \frac{7}{768}r^6 + \frac{13}{8192}r^8 - \frac{49}{204800}r^{10} \\
 &\quad + \frac{73}{2359296}r^{12} - \frac{523}{154140672}r^{14} + \frac{125}{402653184}r^{16} \\
 &\quad - \frac{7}{301989888}r^{18} + \frac{197}{144955146240}r^{20} - \frac{91}{1559073128448}r^{22} \\
 &\quad + \frac{1}{618475290624}r^{24} - \frac{1}{46454366273536}r^{26} \equiv u_3(r).
 \end{aligned}
 \tag{2.8}$$

From (2.8) we infer

$$v(r) \geq 1 - \frac{1}{4}r^2 + \frac{3}{64}r^4 - \frac{7}{768}r^6 + \frac{13}{8192}r^8 - \frac{49}{204800}r^{10} \equiv w_1(r),
 \tag{2.9}$$

for all $r \in [0, 2]$. Hence

$$\begin{aligned}
 -v'(r) &\geq \frac{1}{r} \int_0^r s w_1^3(s) ds \\
 &= \frac{1}{2} r - \frac{3}{16} r^3 + \frac{7}{128} r^5 \\
 &\quad - \frac{29}{2048} r^7 + \frac{277}{81920} r^9 - \frac{1847}{2457600} r^{11} \\
 &\quad + \frac{20603}{137625600} r^{13} - \frac{6809}{251658240} r^{15} + \frac{45467}{10066329600} r^{17} \\
 &\quad - \frac{2507773}{3623878656000} r^{19} + \frac{16945451}{177167400960000} r^{21} \\
 &\quad - \frac{8961701}{773094113280000} r^{23} + \frac{11273477}{8933531975680000} r^{25} \\
 &\quad - \frac{165557}{1374389534720000} r^{27} + \frac{31213}{3435973836800000} r^{29} \\
 &\quad - \frac{117649}{274877906944000000} r^{31} \equiv v_3(r),
 \end{aligned} \tag{2.10}$$

for all $r \in [0, 2]$. From (2.10) we have

$$\begin{aligned}
 v(r) &\leq 1 - \frac{1}{4} r^2 + \frac{3}{64} r^4 - \frac{7}{768} r^6 + \frac{29}{16384} r^8 - \frac{277}{819200} r^{10} \\
 &\quad + \frac{1847}{29491200} r^{12} - \frac{20603}{1926758400} r^{14} \\
 &\quad + \frac{6809}{4026531840} r^{16} - \frac{45467}{181193932800} r^{18} \\
 &\quad + \frac{2507773}{72477573120000} r^{20} - \frac{16945451}{3897682821120000} r^{22} \\
 &\quad + \frac{8961701}{18554258718720000} r^{24} - \frac{11273477}{232271831367680000} r^{26} \\
 &\quad + \frac{165557}{5497558138880000} r^{28} - \frac{31213}{103079215104000000} r^{30} \\
 &\quad + \frac{117649}{8796093022208000000} r^{32} \equiv u_4(r).
 \end{aligned} \tag{2.11}$$

From (2.11) we infer

$$\begin{aligned}
 v(r) &\leq 1 - \frac{1}{4} r^2 + \frac{3}{64} r^4 - \frac{7}{768} r^6 + \frac{29}{16384} r^8 - \frac{277}{819200} r^{10} \\
 &\quad + \frac{1847}{29491200} r^{12} - \frac{20603}{1926758400} r^{14} + \frac{6809}{4026531840} r^{16} \equiv w_2(r).
 \end{aligned} \tag{2.12}$$

Arguing again as in (2.7) we conclude that

$$\begin{aligned}
 -v'(r) &\leq \frac{1}{r} \int_0^r sw_2^3(s)ds = \frac{1}{2}r - \frac{3}{16}r^3 + \frac{7}{128}r^5 \\
 &\quad - \frac{29}{2048}r^7 + \frac{563}{163840}r^9 - \frac{491}{614400}r^{11} \\
 &\quad + \frac{99007}{550502400}r^{13} - \frac{5043}{128450560}r^{15} + \frac{7383233}{887850270720}r^{17} \\
 &\quad - \dots + \frac{315682133129}{3264099712959498771706675200000}r^{49} \\
 &\equiv v_4(r).
 \end{aligned} \tag{2.13}$$

Integration of the latter inequality on $[0, r]$ gives

$$\begin{aligned}
 v(r) &\geq 1 - \int_0^r v_4(s)ds = 1 - \frac{1}{4}r^2 + \frac{3}{64}r^4 \\
 &\quad - \frac{7}{768}r^6 + \frac{29}{16384}r^8 - \frac{563}{1638400}r^{10} \\
 &\quad + \frac{491}{7372800}r^{12} + \frac{99007}{7707033600}r^{14} - \frac{5043}{2055208960}r^{16} \\
 &\quad + \frac{7383233}{15981304872960}r^{18} - \dots \\
 &\quad - \frac{315682133129}{16320498564797493858533376000000}r^{50} \equiv u_5(r).
 \end{aligned} \tag{2.14}$$

From (2.10), (2.11), (2.13), and (2.14) the following lemma is concluded.

Lemma 2.1. *If v is a solution to (2.2), then*

$$\begin{aligned}
 0.42134 &\leq v(2) \leq 0.423697 \\
 -0.344368 &\leq v'(2) \leq -0.332046.
 \end{aligned} \tag{2.15}$$

Iterating the arguments in Lemma 2.1 on $[2, 2.5]$ we obtain

$$\begin{aligned}
 0.258814 &\leq v(2.5) \leq 0.269686 \\
 -0.309722 &\leq v'(2.5) \leq -0.283646.
 \end{aligned} \tag{2.16}$$

Integrating the differential equation (2.2) on $[2.5, r]$ we get

$$\begin{aligned}
 rv'(r) &= 2.5v'(2.5) - \int_{2.5}^r sv^3(s)ds \\
 &\geq 2.5v'(2.5) - v^3(2.5) \int_{2.5}^r sds \\
 &\geq 2.5v'(2.5) + 3.125v^3(2.5) - v^3(2.5)r^2/2,
 \end{aligned} \tag{2.17}$$

provided $v' \leq 0$ on $[2.5, r]$. Thus

$$v'(r) \geq 2.5v'(2.5)/r + 3.125v^3(2.5)/r - v^3(2.5)r/2. \tag{2.18}$$

Integrating (2.18) on $[2.5, r]$ gives

$$v(r) \geq v(2.5) + (2.5v'(2.5) + 3.125v^3(2.5))Ln(r/2.5) - (v^3(2.5)/2)(r^2/2 - 3.125). \quad (2.19)$$

Let

$$w(r) \equiv v(2.5) + (2.5v'(2.5) + 3.125v^3(2.5))Ln(r/2.5) - (v^3(2.5)/2)(r^2/2 - 3.125).$$

By (2.16), $w(3.6115) > 0$. Hence $\alpha > 3.6115$, where α is the first zero of the function v . Since $w(r)$ is convex on $[0, 3.65]$ it follows from (2.19) that

$$\begin{aligned} v(r) &\geq w(2.5) + w'(2.5)(r - 2.5) \\ &= w(2.5) + m(r - 2.5), \end{aligned} \quad (2.20)$$

where $m = -0.309722$.

From (2.20) and the first equation of (2.17) it follows that

$$\begin{aligned} rv'(r) &\leq 2.5v'(2.5) - \int_{2.5}^r s(w(2.5) + m(s - 2.5))^3 ds \\ &\leq 2.5v'(2.5) - r(w(2.5) + m(r - 2.5))^4/(4m) + w(2.5)/(1.6m) \\ &\quad + (w(2.5) + m(r - 2.5))^5/(20m^2) - w^5(2.5)/(20m^2). \end{aligned} \quad (2.21)$$

Thus

$$\begin{aligned} v'(r) &\leq (1/r)(2.5v'(2.5) + w(2.5)/(1.6m) - w^5(2.5)/(20m^2)) \\ &\quad - (w(2.5) + m(r - 2.5))^4/(4m) \\ &\quad + ((w(2.5) - 2.5m) + mr)^5/(20m^2r). \end{aligned} \quad (2.22)$$

Integrating the previous inequality on $[2.5, r]$ we have

$$\begin{aligned} v(r) &\leq v(2.5) + (2.5v'(2.5) + w(2.5)/(1.6m) - w^5(2.5)/(20m^2))Ln(r/2.5) \\ &\quad - ((w(2.5) - 2.5m) + mr)^5/(20m^2) + (w^5(2.5)/(20m^2)) \\ &\quad + \int_{2.5}^r ((w(2.5) - 2.5m) + ms)^5/(20m^2s) ds \\ &\leq v(2.5) + (2.5v'(2.5) + w(2.5)/(1.6m) - w^5(2.5)/(20m^2))Ln(r/2.5) \\ &\quad - ((w(2.5) - 2.5m) + mr)^5/(20m^2) + (w^5(2.5)/(20m^2)) \\ &\quad + \frac{1}{20m^2} \{ (w(2.5) - 2.5m)^5 Ln(r/2.5) \\ &\quad + 5(w(2.5) - 2.5m)^4 m(r - 2.5) \\ &\quad + 5(w(2.5) - 2.5m)^3 m^2 (r^2 - 6.25) \\ &\quad + 10(w(2.5) - 2.5m)^2 m^3 (r^3 - 15.625)/3 \\ &\quad + 5(w(2.5) - 2.5m)m^4 (r^4 - 39.0625)/4 + m^5 (r^5 - 97.65625)/5 \}. \end{aligned} \quad (2.23)$$

Since the right-hand side of (2.23) is less than zero at 3.6415 it follows that $\alpha < 3.6415$. Moreover, from (2.18) and (2.22) we have $-0.231514 \leq v'(\alpha) \leq -0.198982$.

We summarize the above discussion into the following lemma.

Lemma 2.2. *If α is the first zero of the solution v to (2.2), then*

$$3.6115 \leq \alpha \leq 3.6415 \quad \text{and} \quad -0.231514 \leq v'(\alpha) \leq -0.198982. \quad (2.24)$$

Let $r \geq \alpha$ such that $v' < 0$ on $[\alpha, r]$. Since $rv'(r) \geq \alpha v'(\alpha)$ it follows that

$$v(r) \geq \alpha v'(\alpha) \operatorname{Ln}[r/\alpha]. \quad (2.25)$$

By Lemma 2.2 we see that

$$v(r) \geq -.836163 \operatorname{Ln}[r/\alpha]. \quad (2.26)$$

In particular,

$$v(4) \geq -.836163 \operatorname{Ln}[4/\alpha] \equiv q_1(\alpha). \quad (2.27)$$

Since $\alpha \rightarrow -.836163 \operatorname{Ln}[4/\alpha]$ defines an increasing function, it follows that

$$v(4) \geq q_1(3.6115) = -.0854266. \quad (2.28)$$

Integrating the differential equation (2.2) on $[\alpha, r]$ we get

$$rv'(r) = \alpha v'(\alpha) - \int_{\alpha}^r sv^3(s) ds. \quad (2.29)$$

By Lemma 2.2 and (2.26) we see that

$$\begin{aligned} rv'(r) &\leq \alpha v'(\alpha) + (.836163)^3 \int_{\alpha}^r s (\operatorname{Ln}[s/\alpha])^3(s) ds \\ &\leq -.724593 + .219193\alpha^2 - .219193r^2 + .438385r^2 \operatorname{Ln}[r/\alpha] \\ &\quad - .438385r^2 \operatorname{Ln}[r/\alpha]^2 + .292257r^2 \operatorname{Ln}[r/\alpha]^3. \end{aligned} \quad (2.30)$$

In particular,

$$\begin{aligned} v'(4) &\leq -1.057917 + .054798\alpha^2 + 1.755354 \operatorname{Ln}[4/\alpha] \\ &\quad - 1.75354 \operatorname{Ln}[4/\alpha]^2 + 1.16903 \operatorname{Ln}[4/\alpha]^3 \equiv q_2(\alpha). \end{aligned} \quad (2.31)$$

Since the right-hand side of (2.31) defines a decreasing function on $[3.6, 3.65]$ we have that

$$v'(4) \leq q_2(3.6415) = -.181104. \quad (2.32)$$

Similarly, using (2.30) and (2.29), one sees that

$$v(4) \leq -.0680351 \quad \text{and} \quad v'(4) \geq -.209. \quad (2.33)$$

Iterating the previous arguments on $[4, 5.5]$ we obtain

$$\begin{aligned} -0.346445 &\leq v(5.5) \leq -0.298095 \\ -0.13915 &\leq v'(5.5) \leq -0.130904. \end{aligned} \quad (2.34)$$

We now estimate the values of v to the right of 5.5. From (2.34) it follows that

$$\begin{aligned} rv'(r) &= 5.5v'(5.5) - \int_{5.5}^r sv^3(s) ds \\ &\leq 5.5v'(5.5) + (0.346445)^3(r^2 - 5.5^2)/2. \end{aligned} \quad (2.35)$$

Thus

$$v'(r) \leq \frac{-1.3489}{r} + 0.0207909r. \quad (2.36)$$

Let $\gamma > 5.5$ be such that $v'(r) < 0$ for all $r \in (5.5, \gamma)$ and $v'(\gamma) = 0$. From (2.36),

$$0 = v'(\gamma) \leq \frac{-1.3489}{\gamma} + 0.0207909\gamma. \quad (2.37)$$

Hence

$$\gamma \geq 8.054. \quad (2.38)$$

Similarly, one shows that $\gamma < 9.385$.

From (2.36)

$$\begin{aligned} v(r) &\leq v(5.5) - 1.3489Ln(r/5.5) + 0.0103954(r^2 - 5.5^2) \\ &\leq -.298095 - 1.3489Ln(r/5.5) + 0.0103954(r^2 - 5.5^2) \\ &:= p_1(r). \end{aligned} \quad (2.39)$$

In particular

$$v(\gamma) \leq p_1(8.054) = -.452734. \quad (2.40)$$

Since $E(\gamma) \leq E(5.5) \leq .0132836$ (see (2.34)). Thus

$$|v(\gamma)| \leq .480114. \quad (2.41)$$

Now for $r \geq \gamma$ we have

$$rv'(r) = - \int_{\gamma}^r sv^3(s)ds \leq (.480114^3)(\frac{r^2}{2} - \frac{\gamma^2}{2}), \quad (2.42)$$

which implies that

$$\begin{aligned} v(r) &\leq v(\gamma) + (.480114^3)(\frac{r^2}{4} - \frac{\gamma^2}{4} - \frac{\gamma^2}{2}Ln(r/\gamma)) \\ &\leq -.452734 + (.480114^3)(\frac{r^2}{4} - \frac{\gamma^2}{4} - \frac{\gamma^2}{2}Ln(r/\gamma)). \end{aligned} \quad (2.43)$$

Since $\gamma \rightarrow -\frac{\gamma^2}{2}Ln(r/\gamma)$ defines a decreasing function, if $\gamma < 9.47$, then

$$\begin{aligned} v(9.47) &\leq -.452734 + (.480114^3)[\frac{89.6809}{4} - \frac{8.054^2}{4} \\ &\quad - \frac{8.054^2}{2}Ln(9.47/8.054)] \leq -.347533. \end{aligned} \quad (2.44)$$

Thus

$$v(r) \leq v(5.5) \quad \text{for all } r \in (5.5, 9.47). \quad (2.45)$$

Thus (see Theorem 3.1)

$$\tau > 9.47. \quad (2.46)$$

From (2.43) we also see that for $r \geq \gamma$ we have

$$v(r) \leq 5.24072 + 0.0276677r^2 - 3.58944Ln(r) := p_2(r). \quad (2.47)$$

Now

$$\begin{aligned} \int_{\alpha}^{\tau} sv^4(s)ds &\geq \int_{5.5}^{9.47} sv^4(s)ds \\ &\geq \int_{5.5}^{\gamma} sv^4(s)ds + \int_{\gamma}^{9.47} sv^4(s)ds \\ &\geq \int_{5.5}^{\gamma} sp_1^4(s)ds + \int_{\gamma}^{9.47} sp_2^4(s)ds. \end{aligned} \tag{2.48}$$

Let

$$H(\gamma) := \int_{5.5}^{\gamma} sp_1^4(s)ds + \int_{\gamma}^{9.47} sp_2^4(s)ds. \tag{2.49}$$

Since

$$\gamma p_1^4(\gamma) - \gamma p_2^4(\gamma) > 0 \tag{2.50}$$

it follows that H is an increasing function. Thus

$$\int_{\alpha}^{\tau} sv^4(s)ds \geq H(5.5) = \int_{5.5}^{9.47} sp_2^4(s)ds = 0.732512. \tag{2.51}$$

Since (see Lemma 2.2)

$$\alpha^2(v'(\alpha))^2 \leq 0.710747 \tag{2.52}$$

it follows that

$$\int_{\alpha}^{\tau} sv^4(s)ds \geq \alpha^2(v'(\alpha))^2. \tag{2.53}$$

The proof of Theorem 1 follows. □

3. The Least Energy Solution is Nonradial

In this section, as a by-product of Theorem 1, we prove the following result.

Theorem 2. *The boundary value problem*

$$\begin{cases} \Delta u + u^3 = 0 & \text{in } B_1(0) \subset \mathbb{R}^2 \\ u = 0 & \text{on } \partial B_1(0), \end{cases} \tag{3.1}$$

has a solution which is nonradial and changes sign exactly once in $B_1(0)$.

Proof. The existence of a solution to (1.1) that changes sign exactly once follows directly from Theorem 1.1 of [3]. Indeed such a solution u satisfies the variational characterization

$$J(u) = \min_{w \in S_1} J(w), \tag{3.2}$$

where

$$J(w) = \int_{B_1(0)} \left(\frac{1}{2} |\nabla w|^2 - \frac{|w|^4}{4} \right) dx, \tag{3.3}$$

and

$$\begin{aligned}
 S_1 = & \{w \in H_0^1(\Omega) - \{0\} : w_+ \neq 0, w_- \neq 0, \\
 & \int_{B_1(0)} (|\nabla w_+|^2 - |w_+|^4) \, dx = 0, \\
 & \int_{B_1(0)} (|\nabla w_-|^2 - |w_-|^4) \, dx = 0\}.
 \end{aligned}
 \tag{3.4}$$

We now show that u is nonradial. Suppose that u is radial. Let v be the solution to (1.3). Since $w(t) = \tau v(\tau t)$ is also a radial solution to (1.3), $u(r) = w(r) = \tau v(\tau r)$. Let $a \in (0, 1)$ be such that $u(r) > 0$ for $r \in [0, a)$ and $u(r) < 0$ for $r \in (a, 1)$. Hence, by Theorem 1

$$a = \frac{\alpha}{\tau} < \frac{1}{2}.
 \tag{3.5}$$

We define $u_+(x) = \max\{u(x), 0\}$ and $u_-(x) = \min\{u(x), 0\}$. Using (3.3) we obtain

$$J(u_+) = \int_{B_1(0)} \left(\frac{1}{2} |\nabla u_+|^2 - \frac{|u_+|^4}{4} \right) \, dx.
 \tag{3.6}$$

Since $u \in S_1$ it follows that $\int_{B_1(0)} |\nabla u_+|^2 = \int_{B_1(0)} |u_+|^4$. Thus

$$J(u_+) = \int_{B_1(0)} \frac{|u_+|^4}{4} \, dx.
 \tag{3.7}$$

Similarly, we have

$$J(u_-) = \int_{B_1(0)} \frac{|u_-|^4}{4} \, dx.
 \tag{3.8}$$

The crucial ingredient in the proof of Theorem 2 is the following lemma.

Lemma 3.1.

$$J(u_+) \leq J(u_-).
 \tag{3.9}$$

Proof. Using polar coordinates, we see that

$$\int_{\|x\| \leq a} |u(x)|^4 \, dx = 2\pi \int_0^a r |u(r)|^4 \, dr.
 \tag{3.10}$$

and

$$\int_{a \leq \|x\| \leq 1} |u(x)|^4 \, dx = 2\pi \int_a^1 r |u(r)|^4 \, dr.
 \tag{3.11}$$

Thus the proof of Lemma 3.1 follows if we show that

$$\int_0^a r |u(r)|^4 \, dr \leq \int_a^1 r |u(r)|^4 \, dr.
 \tag{3.12}$$

Multiplying the equation in (1.2) by $r^2 u'$ and integrating over $[0, a]$, we obtain

$$\frac{1}{2} \int_0^a r (u(r))^4 = \frac{a^2}{2} (u'(a))^2.
 \tag{3.13}$$

From (3.13), Theorem 1, and the definition of u and v we have

$$\begin{aligned}
 \int_a^1 r(u(r))^4 dr &= \int_a^1 r\tau^4(v(\tau r))^4 dr \\
 &= \tau^2 \int_\alpha^\tau sv^4(s) ds \\
 &\geq \tau^2 \alpha^2 (v'(\alpha))^2 \\
 &= a^2 (u'(a))^2 \\
 &= \int_0^a r(u(r))^4 dr,
 \end{aligned} \tag{3.14}$$

which proves (3.12). This proves the lemma. \square

Let

$$u_1(r) = u_+(r + 1/2), \quad u_2(r) = -u_+(r - 1/2), \tag{3.15}$$

and

$$u^*(r) = u_1(r) + u_2(r). \tag{3.16}$$

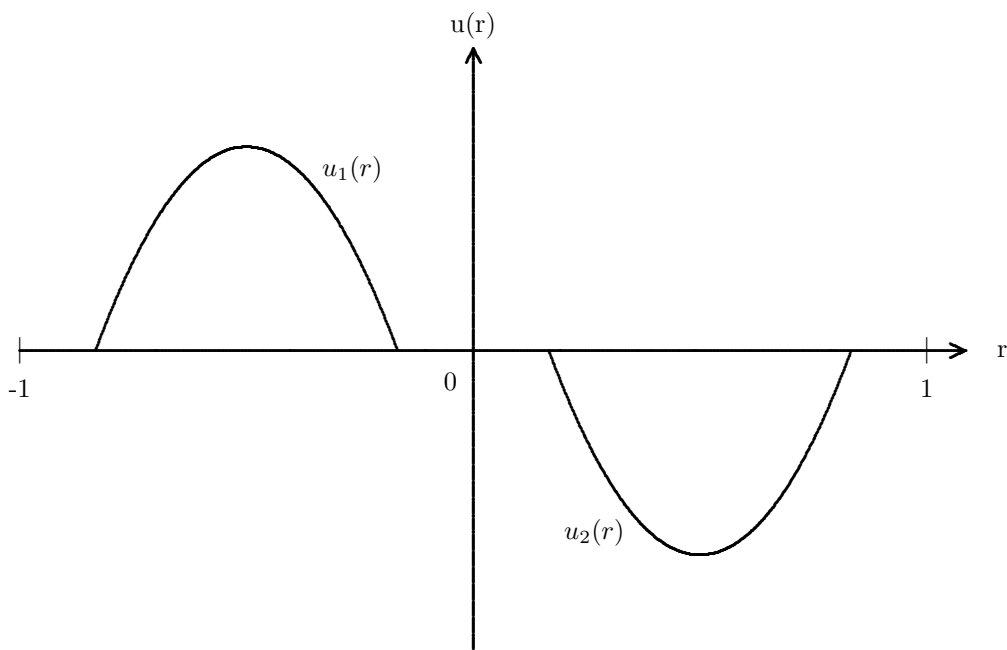

Thus $u^* \in S_1$, and by Lemma 3.1 we have

$$J(u^*) \leq J(u).$$

By [3] we see that u^* is a C^2 -solution to problem (1.1). This is a contradiction. The proof of Theorem 2 follows. \square

References

- [1] A. Aftalion and F. Pacella, *Qualitative properties of nodal solutions of semilinear elliptic equations in radially symmetric domains*, C. R. Acad. Sci. Paris, Ser. I (2004).
- [2] T. Bartsch, T. Weth, and M. Willem, *Partial symmetry of least energy nodal solutions to some variational problems*, preprint 2004.
- [3] A. Castro, J. Cossio, and J. M. Neuberger, *A sign-changing solution for a superlinear Dirichlet problem*, Rocky Mt. J. Math. **27**, No.4 (1997), 1041-1053.
- [4] E. Yanagida, *Structure of radial solutions to $\Delta u + K(|x|)|u|^{p-1}u = 0$ in \mathbf{R}^n* , SIAM J. Math. Anal. **27** (1996), 997-1014.

Alfonso Castro
Department of Mathematics
Harvey Mudd College
Claremont, CA 91711
USA
e-mail: castro@math.hmc.edu

Jorge Cossio
Escuela de Matemáticas
Universidad Nacional de Colombia
Apartado Aéreo 3840
Medellín
Colombia
e-mail: jccossio@unalmed.edu.co

Global Solvability and Asymptotic Stability for the Wave Equation with Nonlinear Boundary Damping and Source Term

M.M. Cavalcanti, V.N. Domingos Cavalcanti and J.A. Soriano

Abstract. We study the global existence and uniform decay rates of solutions of the problem

$$(P) \quad \begin{cases} u_{tt} - \Delta u = |u|^\rho u & \text{in } \Omega \times]0, +\infty[\\ u = 0 & \text{on } \Gamma_0 \times]0, +\infty[\\ \partial_\nu u + g(u_t) = 0 & \text{on } \Gamma_1 \times]0, +\infty[\\ u(x, 0) = u^0(x), \quad u_t(x, 0) = u^1(x); \end{cases}$$

where Ω is a bounded domain of \mathbf{R}^n , $n \geq 1$, with a smooth boundary $\Gamma = \Gamma_0 \cup \Gamma_1$ and $0 < \rho < \frac{2}{n-2}$, $n \geq 3$; $\rho > 0$, $n = 1, 2$.

Assuming that no growth assumption is imposed on the function g near the origin and, moreover, that the initial data are taken inside the Potential Well, we prove existence and uniqueness of regular and weak solutions to problem (P). For this end we use nonlinear semigroup theory arguments inspired in the work of the authors Chueshov, Eller and Lasiecka [5]. Furthermore, uniform decay rates of the energy related to problem (P) are also obtained by considering a similar approach firstly introduced by Lasiecka and Tataru [15]. The present work generalizes the work of the authors Cavalcanti, Domingos Cavalcanti and Martinez [4] and complements the work of Vitillaro [30]. It is important to mention that in [30] no decay result is proved and the dissipative term on the boundary is of a preassigned polynomial growth at the origin.

Keywords. Wave equation, boundary feedback, source term.

1. Introduction

This paper is concerned with the existence and uniform decay rates of solutions of the wave equation with a source term and subject to nonlinear boundary damping

$$\begin{cases} u_{tt} - \Delta u = |u|^p u & \text{in } \Omega \times (0, +\infty) \\ u = 0 & \text{on } \Gamma_0 \times (0, +\infty) \\ \partial_\nu u + g(u_t) = 0 & \text{on } \Gamma_1 \times (0, +\infty) \\ u(x, 0) = u^0(x); \quad u_t(x, 0) = u^1(x), & x \in \Omega, \end{cases} \tag{1.1}$$

where Ω is a bounded domain of \mathbf{R}^n , $n \geq 1$, with a smooth boundary $\Gamma = \Gamma_0 \cup \Gamma_1$. Here, Γ_0 and Γ_1 are closed and disjoint and ν represents the unit outward normal to Γ .

Problems like (1.1), more precisely,

$$\begin{cases} u_{tt} - \Delta u = -f_0(u) & \text{in } \Omega \times (0, +\infty) \\ u = 0 & \text{on } \Gamma_0 \times (0, +\infty) \\ \partial_\nu u = -g(u_t) - f_1(u) & \text{on } \Gamma_1 \times (0, +\infty) \\ u(x, 0) = u^0(x); \quad u_t(x, 0) = u^1(x), & x \in \Omega, \end{cases} \tag{1.2}$$

were widely studied in the literature, mainly when $f_1 = 0$, see [6, 13, 22] and a long list of references therein. When $f_0 \neq 0$ and $f_1 \neq 0$ this kind of problem was well studied by Lasiecka and Tataru [15] for a very general model of nonlinear functions $f_i(s)$, $i = 0, 1$, but assuming that $f_i(s)s \geq 0$, that is, f_i represents, for each i , an attractive force. When $f_i(s)s \leq 0$ as in the present case, the situation is more delicate, since we have a source term and the solutions can blow up in finite time. To summarize the results presented in the literature we start by the works of Levine, Payne and Smith [17, 19]. In [17] the authors considered $f_0 = 0$, $g = 0$, $f_1(s) = -|s|^{p-2}s$ and proved blow up of solutions when the initial energy is negative while in [19] global existence for solutions is proved when, roughly speaking, the initial data are small and $2 < p < 2^* = \frac{2(n-1)}{n-2}$ ($n \geq 3$) is the critical value of the trace-Sobolev imbedding $H^1(\Omega) \hookrightarrow L^p(\partial\Omega)$.

When $f_0 = 0$, $g(s) = s$ and $f_1(s) = -|s|^\gamma s$, Vitillaro [31] proved blow-up phenomenon, when the initial datum u^0 is large enough and u_1 is not too large, so that all possible initial data with negative energy are considered. In Vitillaro [30] the author considers, as in the present paper, the wave equation subject to a source term acting in the domain and nonlinear boundary feedback and he shows existence of global solutions as well as the blow up of weak solutions in finite time. More recently, when $f_0 = 0$, $g(s) = -|s|^{m-2}s$ and $f_1(s) = |s|^{p-2}s$, Vitillaro [32] proved local existence of weak solutions when $m > \frac{2^*}{2^*+1-p}$ and global existence of weak solutions when $p \geq m$ or the initial data are inside the potential well associated to the stationary problem. However, in [30, 31, 32] no decay rate of the energy is proved. It is worth mentioning other papers in connection with the so

called stable set, the Potential Well, developed by Sattinger [27] in 1968, namely, [7, 10, 12, 24, 29] and references therein.

Concerning the wave equation with source and damping terms

$$u_{tt} - \Delta u + g(u_t) = f(u) \quad \text{in } \Omega \times (0, +\infty)$$

where Ω is a bounded domain of \mathbf{R}^n with smooth boundary Γ or Ω is replaced by the entire \mathbf{R}^n , it is important to cite the works of Georgiev and Todorova [8], Levine and Serrin [18], Serrin, Todorova and Vitillaro [26] and Ikehata [9]. All the above mentioned works which involve source and damping terms, except for Cavalcanti, Domingos Cavalcanti and Martinez [4], are marked by the following feature: the damping term possesses a polynomial growth near zero. In the present paper we generalize substantially the results given in [4] in the following sense: (i) g is considered just a monotone nondecreasing continuous function while in [4] this function is assumed to be of $C^1(\mathbf{R})$; (ii) No growth assumption is imposed on the function g near the origin, while in [4] the authors consider $|g_0(s)| \leq |g(s)| \leq |g_0^{-1}(s)|$, $s \in [-1, 1]$, where g_0 is a strictly increasing and odd function of class C^1 ; (iii) Setting $h(x) := x - x^0$, $x^0 \in \mathbf{R}^n$, the unique geometric condition is assumed on the uncontrolled portion of the boundary $\Gamma_0: h \cdot \nu \leq 0$, on Γ_0 , while in [4], in spite of not considering the same condition on Γ_0 , the restrictive geometrical condition is imposed on $\Gamma_1: h \cdot \nu > 0$ on Γ_1 .

Our paper is organized as follows: In section 2 we present some notation, technical information, the assumptions and main results. In section 3 we prove the existence and uniqueness for regular and weak solutions and in section 4 we give the proof of the decay.

2. Notations and Main Result

We start this section by setting the inner products and norms

$$(u, v) = \int_{\Omega} u(x)v(x) \, dx; \quad (u, v)_{\Gamma_1} = \int_{\Gamma_1} u(x)v(x) \, d\Gamma,$$

$$\|u\|_p^p = \int_{\Omega} |u(x)|^p \, dx, \quad \|u\|_{\Gamma_1, p}^p = \int_{\Gamma_1} |u(x)|^p \, d\Gamma.$$

Consider the Hilbert space

$$H_{\Gamma_0}^1(\Omega) = \{v \in H^1(\Omega); v = 0 \text{ on } \Gamma_0\} \tag{2.1}$$

and suppose that

$$(H.1) \quad 0 < \rho < 2/(n - 2) \text{ if } n \geq 3 \text{ and } \rho > 0 \text{ if } n = 1, 2.$$

According to (H.1), we have the imbedding:

$$H_{\Gamma_0}^1(\Omega) \hookrightarrow L^{2(\rho+1)}(\Omega) \hookrightarrow L^{\rho+2}(\Omega).$$

Let $B_1 > 0$ be the optimal constant of Sobolev immersion which satisfies the inequality

$$\|v\|_{\rho+2} \leq B_1 \|\nabla v\|_2; \quad \text{for all } v \in H_{\Gamma_0}^1(\Omega).$$

Let us consider

$$0 < K_0 := \sup_{v \in H_{\Gamma_0}^1(\Omega), v \neq 0} \left(\frac{\frac{1}{\rho+2} \|v\|_{\rho+2}^{\rho+2}}{\|\nabla v\|_2^{\rho+2}} \right) \leq \frac{B_1^{\rho+2}}{\rho+2} \tag{2.2}$$

and the functional

$$J(u) = \frac{1}{2} \|\nabla u\|_2^2 - \frac{1}{\rho+2} \|u\|_{\rho+2}^{\rho+2}; \quad u \in H_{\Gamma_0}^1(\Omega), \tag{2.3}$$

which is well defined in view of the above immersions.

We define the positive number

$$d := \inf_{v \in H_{\Gamma_0}^1(\Omega), v \neq 0} \left\{ \sup_{\lambda > 0} J(\lambda v) \right\}. \tag{2.4}$$

Setting

$$f(\lambda) = \frac{1}{2} \lambda^2 - K_0 \lambda^{\rho+2}; \quad \lambda > 0, \tag{2.5}$$

then, $\lambda_1 = \left(\frac{1}{K_0(\rho+2)} \right)^{1/\rho}$ is the absolute maximum point of f and $d = f(\lambda_1) > 0$.

It is well known that the number d defined in (2.4) is the Mountain Pass level associated to the elliptic problem

$$\begin{cases} -\Delta u = |u|^\rho u & \text{in } \Omega \\ u = 0 & \text{on } \Gamma_0 \\ \partial_\nu u = 0 & \text{on } \Gamma_1. \end{cases}$$

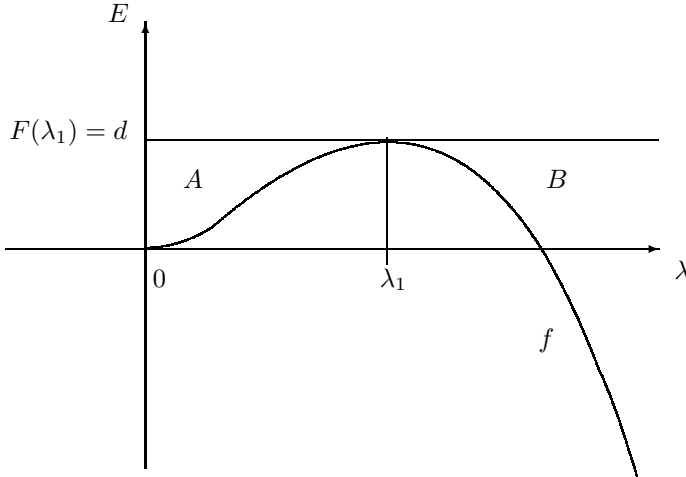

FIGURE 1. The regions A and B are related, respectively, with the existence of global solutions and blow up phenomenon in finite time.

In fact (see Vitillaro [30] for details) d is equal to the number $\inf_{\gamma \in \Lambda} \sup_{t \in [0,1]} J(\gamma(t))$, where $\Lambda = \{\gamma \in C([0, 1]; H^1_{\Gamma_0}(\Omega)); \gamma(0) = 0, J(\gamma(1)) < 0\}$. Furthermore, we have

$$d = f(\lambda_1) = \left(\frac{1}{2} - \frac{1}{\rho + 2}\right) \lambda_1^2 = \frac{\rho}{2(\rho + 2)} \lambda_1^2. \tag{2.6}$$

The energy associated to problem (P) is given by

$$E(t) = \frac{1}{2} \|u_t(t)\|_2^2 + J(u(t)); \quad u \in H^1_{\Gamma_0}(\Omega). \tag{2.7}$$

It is important to observe that from inequality (2.2), we deduce that

$$E(t) \geq J(u(t)) = \frac{1}{2} \|\nabla u(t)\|_2^2 - \frac{1}{\rho + 2} \|u(t)\|_{\rho+2}^{\rho+2} \geq f(\|\nabla u(t)\|_2).$$

Now, if one considers $\|\nabla u(t)\|_2 < \lambda_1$, we arrive at

$$\begin{aligned} E(t) \geq J(u(t)) &\geq \frac{1}{2} \|\nabla u(t)\|_2^2 - K_0 \|\nabla u(t)\|_2^{\rho+2} \\ &\geq \|\nabla u(t)\|_2^2 \left[\frac{1}{2} - \lambda_1^\rho K_0 \right] = \|\nabla u(t)\|_2^2 \left[\frac{1}{2} - \frac{1}{\rho + 2} \right]. \end{aligned}$$

Then,

$$J(u(t)) \geq 0 \text{ (} J(u(t)) = 0 \text{ iff } u = 0 \text{) and } \|\nabla u(t)\|_2^2 \leq \frac{2(\rho + 2)}{\rho} E(t). \tag{2.8}$$

So, we are in a position to consider general hypotheses.

(A.1) Assumptions on g .

Consider $g : \mathbf{R} \rightarrow \mathbf{R}$ a monotone nondecreasing continuous function such that $g(0) = 0$ and satisfying the growth condition

$$(H.2) \quad C_1 |s| \leq |g(s)| \leq C_0 |s|, \quad |s| > 1,$$

where C_0, C_1 are positive constants.

In order to obtain the global existence for regular solutions, the following assumptions are made on the initial data.

(A.2) Assumptions on the Initial Data.

Assume that

$$(H.3) \quad \{u^0, u^1\} \in D(A)$$

where $D(A)$ is defined by

$$D(A) = \{(u, v) \in H^1_{\Gamma_0}(\Omega) \times H^1_{\Gamma_0}(\Omega); u + \mathcal{N}g(\gamma_0 v) \in D(-\Delta)\}$$

and

$$A \begin{pmatrix} u \\ v \end{pmatrix} = \begin{pmatrix} -v \\ -\Delta(u + \mathcal{N}g(\gamma_0 v)) \end{pmatrix}.$$

Here,

$$D(-\Delta) = \{v \in H^1_{\Gamma_0}(\Omega) \cap H^2(\Omega); \partial_\nu v = 0 \text{ on } \Gamma_1\},$$

and $\mathcal{N} : H^{-1/2}(\Gamma_1) \longrightarrow H_{\Gamma_0}^1(\Omega)$ is the Neumann map defined by

$$\mathcal{N}p = q \Leftrightarrow \begin{cases} -\Delta q = 0 & \text{in } \Omega \\ q = 0 & \text{on } \Gamma_0 \\ \partial_\nu q = p & \text{on } \Gamma_1. \end{cases}$$

Taking into account the operator $A : D(A) \subset \mathcal{H} \rightarrow \mathcal{H}$, where $\mathcal{H} = H_{\Gamma_0}^1(\Omega) \times L^2(\Omega)$ and considering $U = \begin{pmatrix} u \\ u' \end{pmatrix}$, we can rewrite problem (1.1) as

$$\frac{dU}{dt} + AU = \begin{pmatrix} 0 \\ |u|^\rho u \end{pmatrix}.$$

Using nonlinear semigroup theory we will prove in section 3 that $(A, D(A))$ is *maximal monotone* in \mathcal{H} . Moreover, since the operator defined by

$$F : H_{\Gamma_0}^1(\Omega) \times L^2(\Omega) \rightarrow H_{\Gamma_0}^1(\Omega) \times L^2(\Omega) \\ (u, v) \mapsto F(u, v) = (0, |u|^\rho u)$$

is locally Lipschitz continuous we will show, making use of arguments due to [5], that for $(u^0, u^1) \in D(A)$ there exists a unique regular solution

$$(u, u_t) \in L^\infty(0, t, H_{\Gamma_0}^1(\Omega) \cap H^2(\Omega)) \times [L^\infty(0, t, H_{\Gamma_0}^1(\Omega)) \cap W^{1,+\infty}(0, t, L^2(\Omega))], \tag{2.9}$$

for $t \in (0, t_{max})$. Furthermore, since $D(A)$ is dense in $H_{\Gamma_0}^1(\Omega) \times L^2(\Omega)$, for $(u^0, u^1) \in \mathcal{H}$ we obtain a unique generalized solution

$$(u, u_t) \in C([0, t_{max}), \mathcal{H}). \tag{2.10}$$

In both cases, $t_{max}(\leq +\infty)$ depends on $\|(u^0, u^1)\|_{\mathcal{H}}$. Moreover,

$$\text{if } t_{max} < +\infty \text{ then } \lim_{t \rightarrow t_{max}} \|(u(t), u_t(t))\|_{\mathcal{H}} = +\infty. \tag{2.11}$$

Let us define the following sets:

$$A = \{(\lambda, E) \in [0, +\infty) \times \mathbb{R}; f(\lambda) \leq E < d; \quad \lambda < \lambda_1\}, \\ B = \{(\lambda, E) \in [0, +\infty) \times \mathbb{R}; f(\lambda) \leq E < d; \quad \lambda > \lambda_1\},$$

according to the figure 1 above.

We recall that:

- (i) If $(\|\nabla u^0\|_2, E(0)) \in A$, then weak solutions possess an extension to the whole interval $[0, +\infty)$.
- (ii) If $(\|\nabla u^0\|_2, E(0)) \in B$, then weak solutions blow up in finite time.

We observe that, in both cases, the initial energy $E(0) < d$ and it can also be negative. So, *one is not expected to obtain global solutions*, even if $E(0) < d$, in view of the item (ii) above. A natural question arises in this context: It would be possible to obtain global solutions if $E(0) \geq d$? This question is very difficult to be answered in a general setting. However, if we assume that: There exists $t_0 \in [0, t_{max})$ such that

$$(H.4) \quad E(u(t_0)) < d \quad \text{and} \quad \|\nabla u(t_0)\|_2 < \lambda_1,$$

the answer is positive.

However, under the assumption that there exists $t_0 \in [0, t_{max})$ such that

$$(H.5) \quad E(u(t_0)) < d \quad \text{and} \quad \|\nabla u(t_0)\|_2 > \lambda_1,$$

solutions will blow up in finite time.

Lemma 2.1. *Under the hypotheses given in (H.4) the regular and weak solutions to problem (1.1) mentioned in (2.9) and (2.10) verify*

$$\|\nabla u(t)\|_2 < \lambda_1, \quad \text{for all } t \in [t_0, t_{max}).$$

Proof. We observe that

$$E(u(t)) \geq \frac{1}{2} \|\nabla u(t)\|_2^2 - K_0 \|u(t)\|_{\rho+2}^{\rho+2} = f(\|\nabla u(t)\|_2), \quad \forall t \in [0, t_{max}). \quad (2.12)$$

We have that f is increasing for $0 < \lambda < \lambda_1$, decreasing for $\lambda > \lambda_1$, $f(\lambda_1) = d$, $f(\lambda) \rightarrow -\infty$ as $\lambda \rightarrow +\infty$. Then, since $d > E(u(t_0)) \geq f(\|\nabla u(t_0)\|_2) \geq f(0) = 0$, there exist $\lambda'_2 < \lambda_1 < \lambda_2$, which verify

$$f(\lambda_2) = f(\lambda'_2) = E(u(t_0)). \quad (2.13)$$

Considering that $E(t)$ is non-increasing, we have

$$E(u(t)) \leq E(u(t_0)), \quad \forall t \in [t_0, t_{max}). \quad (2.14)$$

From (2.12) and (2.13) we deduce

$$f(\|\nabla u(t_0)\|_2) \leq E(u(t_0)) = f(\lambda'_2). \quad (2.15)$$

Since $\|\nabla u(t_0)\|_2 < \lambda_1$, $\lambda'_2 < \lambda_1$ and f is increasing in $[0, \lambda_1)$, from (2.15) it holds that

$$\|\nabla u(t_0)\|_2 \leq \lambda'_2. \quad (2.16)$$

Next, we will prove that

$$\|\nabla u(t)\|_2 \leq \lambda'_2, \quad \forall t \in (t_0, t_{max}). \quad (2.17)$$

In fact, suppose, by contradiction, that (2.17) does not hold. Then, there exists $t^* \in (t_0, t_{max})$ which verifies

$$\|\nabla u(t^*)\|_2 > \lambda'_2. \quad (2.18)$$

If $\|\nabla u(t^*)\|_2 < \lambda_1$, from (2.12), (2.13) and (2.18) we can write

$$E(u(t^*)) \geq f(\|\nabla u(t^*)\|_2) > f(\lambda'_2) = E(u(t_0)),$$

which contradicts (2.14) and proves (2.17).

If $\|\nabla u(t^*)\|_2 \geq \lambda_1$, we have, in view of (2.17), that there exists $\bar{\lambda}$ which verifies

$$\|\nabla u(t_0)\|_2 \leq \lambda'_2 < \bar{\lambda} < \lambda_1 \leq \|\nabla u(t^*)\|_2. \quad (2.19)$$

Consequently, from the continuity of the function $\|\nabla u(\cdot)\|_2$ there exists $\bar{t} \in (t_0, t^*)$ verifying $\|\nabla u(\bar{t})\|_2 = \bar{\lambda}$.

Then, from the last identity and taking (2.12), (2.13) and (2.19) into account we deduce

$$E(u(\bar{t})) \geq f(\|\nabla u(\bar{t})\|_2) = f(\bar{\lambda}) > f(\lambda'_2) = E(u(t_0)),$$

which also contradicts (2.15) and proves (2.18). This completes the proof of Lemma 2.1. \square

Considering Lemma 2.1 and the identity of energy (valid for regular and weak solutions) we conclude that

$$\frac{\rho}{2(\rho + 2)} \|\nabla u(t)\|_2^2 + \frac{1}{2} \|u'(t)\|_2^2 \leq J(u(t)) + \frac{1}{2} \|u'(t)\|_2^2 \leq E(t) \quad (2.20)$$

$$+ \int_{t_0}^t (g(u'(s)), u'(s))_{\Gamma_1} ds = E(t_0) < d \quad \forall t \in [t_0, t_{max}).$$

The last identity yields that $t_{max} = +\infty$.

Now we are in a position to state our main results.

Theorem 2.1. *Under assumptions (H.1)–(H.4), problem (1.1) possesses a unique regular solution u in the class*

$$u \in L_{loc}^\infty(0, \infty; H_{\Gamma_0}^1(\Omega)), \quad u' \in L_{loc}^\infty(0, \infty; H_{\Gamma_0}^1(\Omega)), \quad u'' \in L_{loc}^\infty(0, \infty; L^2(\Omega)) \quad (2.21)$$

and $\|\nabla u(t)\|_2 < \lambda_1$ for all $t \geq t_0$. Furthermore, the energy $E(t)$ given by

$$E(t) = \frac{1}{2} \|u'(t)\|_2^2 + \frac{1}{2} \|\nabla u(t)\|_2^2 - \frac{1}{\rho + 2} \|u(t)\|_{\rho+2}^{\rho+2}, \quad (2.22)$$

has the decay rate

$$E(t) \leq S \left(\frac{t}{T_0} - 1 \right) E(0), \quad (2.23)$$

for all $t \geq T_0 > 0$, where $S(t)$ is the solution of the differential equation

$$S'(t) + q(S(t)) = 0,$$

and q is a positive strictly increasing function defined, in Lasiecka and Tataru [15], as follows.

Let $h : \mathbb{R}_+ \rightarrow \mathbb{R}$ be a concave, strictly increasing function verifying $h(0) = 0$ and, for some $N > 0$,

$$h(sg(s)) \geq s^2 + (g(s))^2, \quad \text{if } |s| \leq N. \quad (2.24)$$

Define

$$\tilde{h}(x) = h \left(\frac{x}{\text{meas}(\Sigma_1)} \right), \quad x \geq 0,$$

where $\Sigma_1 = \Gamma_1 \times (0, T)$ and T is given constant. Setting

$$K := \frac{1}{C(T, E(0)) \text{meas}(\Sigma_1)} \quad \text{and} \quad C := \frac{C_0 + C_1^{-1}}{\text{meas}(\Sigma_1)} \quad (2.25)$$

where C_0 and C_1 are given in (H.2), we define

$$p(x) := (CI + \tilde{h})^{-1}(Kx). \quad (2.26)$$

We observe that p is well defined since \tilde{h} is monotone increasing and, consequently, $CI + \tilde{h}$ is invertible. In addition, p is a positive, continuous, strictly increasing function with $p(0) = 0$. In the sequel, let us define

$$q(x) := x - (I + p)^{-1}(x). \tag{2.27}$$

Then, $q(0) = 0$, q is strictly increasing and $q(x) > 0$ if $x > 0$.

As an example of a function g , we can consider $g(s) = s^p$, $p > 1$ at the origin. Since the function $s^{\frac{p+1}{2}}$ is convex for $p \geq 1$, then solving

$$S_t + S^{\frac{p+1}{2}} = 0, \tag{2.28}$$

we obtain the following decay rate:

$$E(t) \leq C(E(0))[E(0)^{\frac{-p+1}{2}} + t(p-1)]^{\frac{2}{-p+1}}.$$

If $p = 1$ we obtain the exponential decay.

Theorem 2.2. *Let the initial data belong to $H^1_{\Gamma_0}(\Omega) \times L^2(\Omega)$ satisfying (H.4) such that the same hypotheses on g and ρ hold. Then, problem (1.1) possesses a unique weak solution in the class*

$$u \in C^0([0, \infty), H^1_{\Gamma_0}(\Omega)) \cap C^1([0, \infty); L^2(\Omega)), \tag{2.29}$$

and $\|\nabla u(t)\|_2 < \lambda_1$ for all $t \geq t_0$. Besides, the weak solution has the same decay given in (2.23).

3. Existence of Solutions

In this section we prove the existence and uniqueness of regular and weak solutions to problem (1.1) by using nonlinear semigroup procedure following similar steps introduced in [5] to our context.

Let $-\Delta$ be the operator defined by the triple $\{H^1_{\Gamma_0}(\Omega), L^2(\Omega), a(u, v)\}$ where $a(u, v) = \int_{\Omega} \nabla u \cdot \nabla v \, dx$; $u, v \in H^1_{\Gamma_0}(\Omega)$. It is well known that the above operator is an unbounded one whose domain, $D(-\Delta)$, is given by

$$D(-\Delta) = \{v \in H^1_{\Gamma_0}(\Omega) \cap H^2(\Omega); \frac{\partial v}{\partial \nu} = 0 \text{ on } \Gamma_1\}. \tag{3.1}$$

This operator is densely defined, injective and self-adjoint. Moreover, it can be isometrically extended to $-\tilde{\Delta} : H^1_{\Gamma_0}(\Omega) \rightarrow (H^1_{\Gamma_0}(\Omega))'$, where $(H^1_{\Gamma_0}(\Omega))'$ is the topological dual of $H^1_{\Gamma_0}(\Omega)$ and this extension is defined by

$$\left\langle -\tilde{\Delta}u, v \right\rangle_{(H^1_{\Gamma_0}(\Omega))', H^1_{\Gamma_0}(\Omega)} = (\nabla u, \nabla v)_{L^2(\Omega)}; \text{ for all } u, v \in H^1_{\Gamma_0}(\Omega). \tag{3.2}$$

From now on, for simplicity, we will denote $-\tilde{\Delta}$ by $-\Delta$. We observe that $-\Delta$ is a positive operator, so that we can define the fractional powers of it. According to Lions-Magenes [[21], page 12] we also have that

$$D(-\Delta^{1/2}) = H^1_{\Gamma_0}(\Omega). \tag{3.3}$$

Using elliptic theory, see Lions-Magenes [[21] page 189], we deduce that the Neumann map introduced before,

$$\mathcal{N} : H^s(\Gamma_1) \rightarrow H_{\Gamma_0}^{s+3/2}(\Omega), \tag{3.4}$$

is continuous for all $s \in \mathbb{R}$, which implies that \mathcal{N} is closed and, consequently, $D(\mathcal{N}^*) = (H_{\Gamma_0}^{s+3/2}(\Omega))'$ and

$$\mathcal{N}^* : (H_{\Gamma_0}^{s+3/2}(\Omega))' \rightarrow H^{-s}(\Gamma_1) \tag{3.5}$$

is continuous, verifying $\|\mathcal{N}\|_{\mathcal{L}(H^s(\Gamma_1), H_{\Gamma_0}^{s+3/2}(\Omega))} = \|\mathcal{N}^*\|_{\mathcal{L}((H_{\Gamma_0}^{s+3/2}(\Omega))', H^{-s}(\Gamma_1))}$.

Moreover, we have

$$\langle \mathcal{N}^* w, u \rangle_{H^{-s}(\Gamma_1), H^s(\Gamma_1)} = \langle w, \mathcal{N} u \rangle_{(H_{\Gamma_0}^{s+3/2}(\Omega))', H_{\Gamma_0}^{s+3/2}(\Omega)}, \tag{3.6}$$

for $u \in H^s(\Gamma_1), w \in (H_{\Gamma_0}^{s+3/2}(\Omega))'$.

Next, we will prove that

$$\mathcal{N}^*(-\Delta v) = v|_{\Gamma_1} = \gamma_0 v; \quad \text{for all } v \in H_{\Gamma_0}^1(\Omega). \tag{3.7}$$

For this end, it is sufficient to prove the above identity for all $v \in D(-\Delta)$, since $D(-\Delta)$ is dense in $H_{\Gamma_0}^1(\Omega)$. So, let $v \in D(-\Delta)$. Then, from (3.1) we have

$$-\Delta v \in L^2(\Omega) \subset (H_{\Gamma_0}^1(\Omega))' \text{ and } \frac{\partial v}{\partial \nu} = 0 \text{ on } \Gamma_1. \tag{3.8}$$

Considering, particularly, $s = -1/2$ and $w = -\Delta v$ in (3.6), we deduce, for all $q \in H^{-1/2}(\Gamma_1)$, that

$$\langle \mathcal{N}^*(-\Delta v), q \rangle_{H^{1/2}(\Gamma_1), H^{-1/2}(\Gamma_1)} = \langle -\Delta v, \mathcal{N} q \rangle_{(H_{\Gamma_0}^1(\Omega))', H_{\Gamma_0}^1(\Omega)}. \tag{3.9}$$

Let p be the solution of the elliptic problem

$$\begin{aligned} \Delta p &= 0 \quad \text{in } \Omega \\ p &= 0 \quad \text{on } \Gamma_0 \quad \Leftrightarrow \mathcal{N} q = p \\ \partial_\nu p &= q \quad \text{on } \Gamma_1. \end{aligned} \tag{3.10}$$

Then, from (3.8), (3.9), (3.10) and making use of the generalized Green formula into account, we prove (3.7). We recall that we are considering, from now on, the operators $\mathcal{N} : H^{-1/2}(\Gamma_1) \rightarrow H_{\Gamma_0}^1(\Omega)$ and $\mathcal{N}^* : (H_{\Gamma_0}^1(\Omega))' \rightarrow H^{1/2}(\Gamma_1)$. Observe that if $v \in H_{\Gamma_0}^1(\Omega)$ and, therefore, $\gamma_0 v \in H^{1/2}(\Gamma_1) \subset L^2(\Gamma_1)$, from the assumption (H.2) on g , the map $v \in H_{\Gamma_0}^1(\Omega) \mapsto g(\gamma_0 v) \in L^2(\Gamma_1)$ is well defined since

$$\|g(\gamma_0 v)\|_{2, \Gamma_1}^2 = \int_{\Gamma_1} |g(\gamma_0 v(x))|^2 d\Gamma \leq C \int_{\Gamma_1} (1 + |\gamma_0(v(x))|)^2 d\Gamma < +\infty,$$

where C is a positive constant. Moreover, making use of [[1], Theorem IV.9], the Lebesgue Dominate Convergence Theorem and considering the assumption (H.2) we can prove that the map $v \mapsto g(\gamma_0 v)$ is continuous from $H_{\Gamma_0}^1(\Omega)$ in $L^2(\Gamma_1)$.

From the above considerations, let us introduce the nonlinear operator A , whose domain is defined by

$$D(A) = \{(u, v) \in H_{\Gamma_0}^1(\Omega) \times H_{\Gamma_0}^1(\Omega); u + \mathcal{N}g(\gamma_0 v) \in D(-\Delta)\} \tag{3.11}$$

by setting

$$A \begin{pmatrix} u \\ v \end{pmatrix} = \begin{pmatrix} 0 & -I \\ -\Delta & -\Delta \mathcal{N}g(\gamma_0 \cdot) \end{pmatrix} \begin{pmatrix} u \\ v \end{pmatrix}.$$

Setting $U = \begin{pmatrix} u \\ u' \end{pmatrix} \in D(A)$, we can rewrite problem (1.1) as

$$\frac{dU}{dt} + AU = \begin{pmatrix} 0 \\ |u|^{\rho}u \end{pmatrix}.$$

We shall prove that $(A, D(A))$ is maximal monotone in $\mathcal{H} = H_{\Gamma_0}^1(\Omega) \times L^2(\Omega)$ equipped with norm

$$\left[\begin{matrix} u \\ v \end{matrix} \right]_{\mathcal{H}} := \|\nabla u\|_2^2 + \|v\|_2^2, \quad \text{where } \|v\|_2^2 = \int_{\Omega} |v(x)|^2 dx.$$

According to Brézis[[2], Prop. 2.2], it is sufficient to prove that

$$(Au - Av, u - v)_{\mathcal{H}} \geq 0; \text{ for all } u, v \in D(A), \quad (\text{monotonicity condition}) \tag{3.12}$$

and

$$R(I + A) = \mathcal{H} \quad (\text{maximality condition}). \tag{3.13}$$

The operator A is clearly monotone on \mathcal{H} since g is monotonic increasing, which proves (3.12).

In what follows we will prove (3.13), that is, A is maximal monotone. Indeed, given $\begin{bmatrix} h_1 \\ h_2 \end{bmatrix} \in H_{\Gamma_0}^1(\Omega) \times L^2(\Omega)$ we have to prove the existence of $\begin{bmatrix} u \\ v \end{bmatrix} \in D(A)$ such that

$$\begin{cases} u - v = h_1 \\ v - \Delta(u + \mathcal{N}g(\gamma_0 v)) = h_2. \end{cases} \tag{3.14}$$

From (3.7), we can rewrite (3.14) as

$$\begin{cases} u - v = h_1 \\ v - \Delta(u + \mathcal{N}g\mathcal{N}^*(-\Delta v)) = h_2 \end{cases} \tag{3.15}$$

or, substituting $u = v + h_1$ in the second equation of (3.15), we obtain

$$-\Delta v + Iv - \Delta(\mathcal{N}g\mathcal{N}^*(-\Delta v)) = h := h_2 + \Delta h_1 \in (H_{\Gamma_0}^1(\Omega))'. \tag{3.16}$$

Having (3.16) in mind we define

$$B := (-\Delta) \circ \mathcal{N} \circ g \circ \mathcal{N}^* \circ (-\Delta). \tag{3.17}$$

Let us consider the duality application given by $F : H_{\Gamma_0}^1(\Omega) \rightarrow (H_{\Gamma_0}^1(\Omega))'$ and the extension of the Laplacian operator $-\Delta : H_{\Gamma_0}^1(\Omega) \rightarrow (H_{\Gamma_0}^1(\Omega))'$. Then, given $v \in H_{\Gamma_0}^1(\Omega)$ there exists $v' \in (H_{\Gamma_0}^1(\Omega))'$ such that $F(v) = v'$.

Moreover, from the above comments and taking (3.2) into account one has $\langle v', v \rangle = \|v'\|_{(H^1_{\Gamma_0}(\Omega))'}^2 = \|v\|_{H^1_{\Gamma_0}(\Omega)}^2 = (\nabla v, \nabla v) = \langle -\Delta v, v \rangle$ which implies that $-\Delta v = v' = F(v)$ for all $v \in H^1_{\Gamma_0}(\Omega)$. Consequently $-\Delta : H^1_{\Gamma_0}(\Omega) \rightarrow (H^1_{\Gamma_0}(\Omega))'$ is the duality application.

Then, considering (3.16), (3.17) and Barbu [[3], Theorem 1.2, Chap. II], the mapping

$$-\Delta + (I + B) : H^1_{\Gamma_0}(\Omega) \rightarrow (H^1_{\Gamma_0}(\Omega))' \tag{3.18}$$

is onto if and only if $(I + B)$ is maximal monotone in $H^1_{\Gamma_0}(\Omega) \times (H^1_{\Gamma_0}(\Omega))'$. So, in order to prove that $-\Delta + (I + B)$ is onto, we are going to prove that $I + B$ is maximal monotone. In fact, for this end, identifying $L^2(\Gamma_1)$ with its dual $(L^2(\Gamma_1))'$, let us introduce the operator $G : H^{1/2}(\Gamma_1) \rightarrow (L^2(\Gamma_1))' \hookrightarrow H^{-1/2}(\Gamma_1)$, defined by

$$(Gu, v)_{L^2(\Gamma_1)} := \int_{\Gamma_1} g(u) v \, d\Gamma, \text{ for all } v \in L^2(\Gamma_1). \tag{3.19}$$

From the above identification we deduce that $Gz = g \circ z$ for all $z \in H^{1/2}(\Gamma_1)$. On the other hand, let us introduce the functional $\phi : H^{1/2}(\Gamma_1) \rightarrow \mathbb{R}$ defined by

$$\phi(u) := \int_{\Gamma_1} \int_0^{u(x)} g(\tau) \, d\tau \, d\Gamma. \tag{3.20}$$

which, in view of the assumptions made on g , is continuous in $H^{1/2}(\Gamma_1)$. Consequently we deduce that

$$\langle \phi'(u), v \rangle = \int_{\Gamma_1} g(u) v \, d\Gamma. \tag{3.21}$$

Then, from (3.19) and (3.21) it holds that

$$\phi'(u) = Gu = g \circ u, \text{ for all } u \in H^{1/2}(\Gamma_1). \tag{3.22}$$

From the fact that ϕ is convex, taking (3.22) into account and employing Showalter [[28], Prop. 7.6, Chap. II] we have

$$\phi'(u) = Gu = g \circ u = \partial\phi(u), \tag{3.23}$$

where $\partial\phi(u)$ is the sub-differential of ϕ at u .

On the other hand, defining $\Lambda := \mathcal{N}^* \circ (-\Delta)$, it follows that $\Lambda^* = (-\Delta)^* \circ \mathcal{N}^{**} = -\Delta \circ \mathcal{N}$. From this fact we can rewrite (3.17) as

$$B = \Lambda^* \circ g \circ \Lambda. \tag{3.24}$$

We observe that the linear operator $\Lambda : H^1_{\Gamma_0}(\Omega) \rightarrow H^{1/2}(\Gamma_1)$ is continuous as well as the same occurs to the functional $\phi : H^{1/2}(\Gamma_1) \rightarrow \mathbb{R}$. Then, making use of Showalter[[28], Prop. 7.8, Cap. II], we deduce from (3.23) and (3.24) that

$$B = \partial(\phi \circ \Lambda) = \partial(\phi \circ \mathcal{N}^* \circ (-\Delta)). \tag{3.25}$$

As the functional ϕ is convex and since $\mathcal{N}^* \circ (-\Delta)$ is linear, then $\phi \circ \Lambda = \phi \circ \mathcal{N}^* \circ (-\Delta)$ is convex. Now, observing that ϕ is continuous, from (3.25), according to Barbu [[3], Theorem 2.1, Chap. II] we deduce that

$$\partial(\phi \circ \Lambda) = B \quad \text{is maximal monotone.} \tag{3.26}$$

Since the identity I considered as a mapping from $H_{\Gamma_0}^1(\Omega)$ into $(H_{\Gamma_0}^1(\Omega))'$ is bounded, continuous and monotone, the mapping

$$I + B \quad \text{is maximal monotone,} \tag{3.27}$$

as well, see Barbu[[3], Corollary 1.1, Chap. II].

Returning to (3.18), one has that $-\Delta + (I + B) : H_{\Gamma_0}^1(\Omega) \rightarrow (H_{\Gamma_0}^1(\Omega))'$ is onto. Consequently as $h = h_2 + \Delta h_1 \in (H_{\Gamma_0}^1(\Omega))'$, there exists $v \in H_{\Gamma_0}^1(\Omega)$ verifying the equation given in (3.16). Then, from (3.14) and (3.15), we deduce that

$$\begin{aligned} u &= v + h_1 \in H_{\Gamma_0}^1(\Omega) + H_{\Gamma_0}^1(\Omega) \subset H_{\Gamma_0}^1(\Omega), \\ &\text{and} \\ -\Delta(u + \mathcal{N}g(\gamma_0 v)) &= h_2 - v \in L^2(\Omega) + H_{\Gamma_0}^1(\Omega) \subset L^2(\Omega). \end{aligned}$$

Having in mind that $D(-\Delta) = \{w \in H_{\Gamma_0}^1(\Omega); \Delta w \in L^2(\Omega)\}$, we have proved that $(u, v) \in D(A)$, or, in other words, that the operator A defined in (3.11) and (3.12) is maximal monotone, as we desired to prove.

We observe that the operator defined by

$$\begin{aligned} F : H_{\Gamma_0}^1(\Omega) \times L^2(\Omega) &\rightarrow H_{\Gamma_0}^1(\Omega) \times L^2(\Omega) \\ (u, v) &\mapsto F(u, v) = (0, |u|^\rho u) \end{aligned}$$

is locally Lipschitz continuous.

To end this section it remains to prove that

$$D(A) \text{ is dense in } H_{\Gamma_0}^1(\Omega) \times L^2(\Omega). \tag{3.28}$$

Indeed, firstly we will prove that

$$D(-\Delta) \times H_0^1(\Omega) \subset D(A). \tag{3.29}$$

Let $(u, v) \in D(-\Delta) \times H_0^1(\Omega) \subset D(A)$. Then,

$$u \in H_{\Gamma_0}^1(\Omega) \cap H^2(\Omega), \frac{\partial u}{\partial \nu} = 0 \text{ on } \Gamma_1 \text{ and } v \in H_0^1(\Omega). \tag{3.30}$$

Since $g(0) = 0$ and $v \in H_0^1(\Omega)$ we conclude that $g(\gamma_0 v) = 0$ on Γ_1 , and therefore,

$$\mathcal{N}(g(\gamma_0 v)) = 0 \text{ as a function of } H_{\Gamma_0}^1(\Omega). \tag{3.31}$$

So, from (3.30) and (3.31) we conclude (3.29). From this result and noting that $D(-\Delta)$ is dense in $H_{\Gamma_0}^1(\Omega)$ and $H_0^1(\Omega)$ is dense in $L^2(\Omega)$, we have proved (3.28).

The equation

$$\frac{dU}{dt} + AU = F \begin{pmatrix} u \\ u_t \end{pmatrix}$$

represents a locally Lipschitz perturbation of an evolution equation with a maximal monotone generator. Hence, according to Chueshov, Eller and Lasiecka [[5], Theorem 7.2], for $(u^0, u^1) \in D(A)$ there exists a unique regular solution

$$(u, u_t) \in L^\infty(0, t, H^1_{\Gamma_0}(\Omega) \cap H^2(\Omega)) \times [L^\infty(0, t, H^1_{\Gamma_0}(\Omega)) \cap W^{1,+\infty}(0, t, L^2(\Omega))],$$

for $t \in (0, t_{max})$. Furthermore, since $D(A)$ is dense in $H^1_{\Gamma_0}(\Omega) \times L^2(\Omega)$, for $(u^0, u^1) \in \mathcal{H}$ we obtain a unique generalized solution

$$(u, u_t) \in C([0, t_{max}), \mathcal{H}).$$

In both cases, $t_{max}(\leq +\infty)$ depends on $\|(u^0, u^1)\|_{\mathcal{H}}$. Moreover,

$$\text{if } t_{max} < +\infty \text{ then } \lim_{t \rightarrow t_{max}} \|(u(t), u_t(t))\|_{\mathcal{H}} = +\infty. \quad \square$$

4. Uniform Decay

In this section we prove decay rate estimates for regular solutions of (1.1) and, assuming standard density arguments, we can also extend our results to weak solutions.

Lemma 4.1. *Assume that $h(x) = x - x^0$, $x^0 \in \mathbb{R}^n$ satisfies $h \cdot \nu \leq 0$ on Γ_0 and let u be the regular solution to problem (1.1) defined in Theorem 2.1. Then,*

$$\begin{aligned} & \int_{\alpha}^{T-\alpha} [\|u_t(t)\|_2^2 + \|\nabla u(t)\|_2^2] dt \\ & \leq C \left[\|u_t\|_{L^\infty(0,T;L^2(\Omega))}^2 + \|\nabla u\|_{L^\infty(0,T;L^2(\Omega))}^2 \right] \\ & \quad + C_{\alpha,\beta} \left[\int_{\Sigma_1} \left(|u_t|^2 + \left| \frac{\partial u}{\partial \nu} \right|^2 \right) d\Sigma + \int_Q |u|^{2(\rho+1)} dQ \right] \\ & \quad + C \int_Q |u|^{\rho+2} dQ + C_{T,\alpha,\beta} \|u\|_{L^2(0,T;H^{1/2+\beta}(\Omega))}, \end{aligned}$$

where the constants $C, C_{\alpha,\beta}$ are independent of T ; and $0 < \rho < 1/2$, $\alpha > 0$ are arbitrarily small but fixed.

Proof. Multiplying the equation $u_{tt} - \Delta u = |u|^\rho u$ by $2(h \cdot \nabla u)$ and $(n - 1)u$ it results that

$$\begin{aligned} & \int_0^T \int_{\Omega} [|u_t|^2 + |\nabla u|^2] dx dt + 2 \left[\int_{\Omega} u_t (h \cdot \nabla u) dx \right]_0^T + (n - 1) \left[\int_{\Omega} u_t u dx \right]_0^T \\ & - \int_0^T \int_{\Gamma_1} (h \cdot \nu) (u_t)^2 d\Gamma dt - \int_0^T \int_{\Gamma} (h \cdot \nu) \left| \frac{\partial u}{\partial \nu} \right|^2 d\Gamma dt \\ & + \int_0^T \int_{\Gamma} (h \cdot \nabla u) |\nabla_{\sigma} u|^2 d\Gamma dt - (n - 1) \int_0^T \int_{\Gamma_1} \frac{\partial u}{\partial \nu} u d\Gamma dt \\ & = (n - 1) \int_0^T \int_{\Omega} |u|^{\rho+2} dx dt + 2 \int_0^T \int_{\Omega} |u|^\rho u (h \cdot \nabla u) dx dt, \end{aligned} \tag{4.1}$$

where $\nabla_{\sigma} u$ means the tangential gradient of u .

Taking into account that $h \cdot \nu \leq 0$ on Γ_0 and $\nabla_\sigma u = 0$ on Γ_0 , the above identity yields

$$\begin{aligned} & \int_0^T \int_\Omega [|u_t|^2 + |\nabla u|^2] dx dt \leq C_1 \|u_t\|_{L^\infty(0,T;L^2(\Omega))} + C_2 \|\nabla u\|_{L^\infty(0,T;L^2(\Omega))}^2 \\ & + C_3 \int_0^T \int_{\Gamma_1} |u_t|^2 d\Gamma dt + C_4 \int_0^T \int_{\Gamma_1} \left| \frac{\partial u}{\partial \nu} \right|^2 d\Gamma dt + C_5 \int_0^T \int_{\Gamma_1} |\nabla_\sigma u|^2 d\Gamma dt \\ & + C_6(\varepsilon) \int_0^T \int_{\Gamma_1} \left| \frac{\partial u}{\partial \nu} \right|^2 d\Gamma dt + \varepsilon \int_0^T \int_\Omega |\nabla u|^2 dx dt + C_7 \int_0^T \int_\Omega |u|^{\rho+2} dx dt \\ & + C_8(\varepsilon) \int_0^T \int_\Omega |u|^{2(\rho+1)} dx dt + \varepsilon \int_0^T \int_\Omega |\nabla u|^2 dx dt, \end{aligned}$$

where ε is an arbitrary positive constant.

From the above inequality and considering ε suitably small, we obtain

$$\begin{aligned} & \int_0^T \int_\Omega [|u_t|^2 + |\nabla u|^2] dx dt \leq C \left\{ \|u_t\|_{L^\infty(0,T;L^2(\Omega))} + \|\nabla u\|_{L^\infty(0,T;L^2(\Omega))}^2 \right. \\ & + \int_0^T \int_{\Gamma_1} |u_t|^2 d\Gamma dt + \int_0^T \int_{\Gamma_1} \left| \frac{\partial u}{\partial \nu} \right|^2 d\Gamma dt + \int_0^T \int_{\Gamma_1} |\nabla_\sigma u|^2 d\Gamma dt \\ & \left. + \int_0^T \int_{\Gamma_1} \left| \frac{\partial u}{\partial \nu} \right|^2 d\Gamma dt + \int_0^T \int_\Omega |u|^{\rho+2} dx dt + \int_0^T \int_\Omega |u|^{2(\rho+1)} dx dt \right\}, \end{aligned} \tag{4.2}$$

where C is a positive constant.

On the other hand, observing Lasiecka and Triggiani [16] or Lasiecka and Tataru [15] we have that for $\alpha > 0$ and $0 < \beta < \frac{1}{2}$ small enough, arbitrary, but fixed, one has

$$\begin{aligned} & \int_\alpha^{T-\alpha} \int_{\Gamma_1} |\nabla_\sigma u|^2 d\Gamma dt \leq C_{\alpha,\beta} \left[\int_{\Sigma_1} \left(\left| \frac{\partial u}{\partial \nu} \right|^2 + |u_t|^2 \right) d\Sigma \right. \\ & \left. + C_T \|u\|_{L^2(0,T;H^{1/2+\beta}(\Omega))} + \int_Q |u|^{2(\rho+1)} dQ \right]. \end{aligned}$$

Considering in (4.2) the interval $(\alpha, T - \alpha)$ instead of $(0, T)$ and applying the last inequality we conclude the desired result. So, Lemma 4.1 is proved. \square

Since $u_{tt} - \Delta u - |u|^\rho u = 0$ we conclude, after multiplying by u_t and integrating over Ω that

$$\frac{1}{2} \frac{d}{dt} \|u_t(t)\|_2^2 + \frac{1}{2} \frac{d}{dt} \|\nabla u(t)\|_2^2 + \int_{\Gamma_1} g(u_t) u_t d\Gamma - \frac{1}{\rho + 2} \frac{d}{dt} \|u(t)\|_{\rho+2}^{\rho+2} = 0,$$

that is,

$$E'(t) = - \int_{\Gamma_1} g(u_t) u_t d\Gamma \leq 0, \quad t \geq 0. \tag{4.3}$$

Consequently $E(t)$ is non-increasing. From the definition of $E(t)$ given in (2.7) and from (2.8), we get that

$$\|u_t(t)\|_2^2 + \|\nabla u(t)\|_2^2 \leq CE(t) \leq CE(0), \quad t \geq 0, \tag{4.4}$$

where C depends uniquely on ρ . Taking the essential supreme in (4.4) over $[0, T]$, it yields that

$$\|u_t\|_{L^\infty(0,T;L^2(\Omega))}^2 + \|\nabla u\|_{L^\infty(0,T;L^2(\Omega))}^2 \leq CE(0). \tag{4.5}$$

On the other hand, (4.3) implies that

$$E(t) + \int_0^t \int_{\Gamma_1} g(u_t)u_t \, d\Gamma \, ds = E(0), \quad t > 0. \tag{4.6}$$

Replacing (4.6) in (4.5) with $t = T$, we obtain

$$\begin{aligned} & \|u_t\|_{L^\infty(0,T;L^2(\Omega))}^2 + \|\nabla u\|_{L^\infty(0,T;L^2(\Omega))}^2 \leq C \left[E(T) + \int_0^T \int_{\Gamma_1} g(u_t)u_t \, d\Gamma \, ds \right] \\ & \leq C \left[E(T) + \int_{\Sigma_1} (|g(u_t)|^2 + |u_t|^2) \, d\Sigma \right]. \end{aligned} \tag{4.7}$$

From (4.7) and Lemma 4.1 we conclude that

$$\begin{aligned} & \int_\alpha^{T-\alpha} [\|u_t(t)\|_2^2 + \|\nabla u(t)\|_2^2] dt \leq C_{\alpha,\beta} \left[E(T) + \int_{\Sigma_1} (|g(u_t)|^2 + |u_t|^2) \, d\Sigma \right. \\ & \left. + \int_Q |u|^{2(\rho+1)} \, dQ + \int_Q |u|^{\rho+2} \, dQ \right] + C_{T,\alpha,\beta} \|u\|_{L^2(0,T;H^{1/2+\beta}(\Omega))}. \end{aligned} \tag{4.8}$$

Using again (4.4) and (4.6) with $t = T$ and $\alpha > 0$ given before, we deduce

$$\begin{aligned} & \int_0^\alpha [\|u_t(t)\|_2^2 + \|\nabla u(t)\|_2^2] dt + \int_{T-\alpha}^T [\|u_t(t)\|_2^2 + \|\nabla u(t)\|_2^2] dt \\ & \leq CE(0)[(\alpha - 0) + (T - (T - \alpha))] = 2\alpha C E(0) \\ & \leq 2\alpha C \left[E(T) + \int_{\Sigma_1} (|g(u_t)|^2 + |u_t|^2) \, d\Sigma \right]. \end{aligned} \tag{4.9}$$

Combining (4.8) and (4.9) it holds that

$$\begin{aligned} & \int_0^T [\|u_t(t)\|_2^2 + \|\nabla u(t)\|_2^2] dt \leq C_{\alpha,\beta} \left[E(T) + \int_{\Sigma_1} (|g(u_t)|^2 + |u_t|^2) \, d\Sigma \right. \\ & \left. + \int_Q |u|^{2(\rho+1)} \, dQ + \int_Q |u|^{\rho+2} \, dQ \right] + C_{T,\alpha,\beta} \|u\|_{L^2(0,T;H^{1/2+\beta}(\Omega))}. \end{aligned} \tag{4.10}$$

We observe from Lions and Magenes [[21], Chapter 1, pag. 112, Theorem 16.3] that, for all $\varepsilon > 0$, the following inequality holds:

$$C_{T,\alpha,\beta} \|u\|_{L^2(0,T;H^{1/2+\beta}(\Omega))}^2 \leq 2\varepsilon^2 \int_0^T \|\nabla u(t)\|_2^2 dt + 2C_{T,\alpha,\beta}^2(\varepsilon) \int_0^T \|u(t)\|_2^2 dt. \tag{4.11}$$

Replacing (4.11) in (4.10) with $\varepsilon > 0$ sufficiently small, we obtain

$$\begin{aligned} & \int_0^T [\|u_t(t)\|_2^2 + \|\nabla u(t)\|_2^2] dt \leq C_{\alpha,\beta} \left[E(T) + \int_{\Sigma_1} (|g(u_t)|^2 + |u_t|^2) \, d\Sigma \right. \\ & \left. + \int_Q |u|^{2(\rho+1)} \, dQ + \int_Q |u|^{\rho+2} \, dQ \right] + C_{T,\alpha,\beta} \int_Q |u|^2 \, dQ. \end{aligned}$$

From the above inequality we conclude that

$$\begin{aligned} & \int_0^T [\|u_t(t)\|_2^2 + \|\nabla u(t)\|_2^2 - \frac{2}{\rho+2} \|u(t)\|_{\rho+2}^{\rho+2}] dt \\ & \leq C_{\alpha,\beta} \left[E(T) + \int_{\Sigma_1} (|g(u_t)|^2 + |u_t|^2) \, d\Sigma \right. \\ & \left. + \int_Q |u|^{2(\rho+1)} \, dQ + \int_Q |u|^{\rho+2} \, dQ \right] + C_{T,\alpha,\beta} \int_Q |u|^2 \, dQ. \end{aligned}$$

or, equivalently, we obtain the following result.

Lemma 4.2. *Under the same hypotheses as in Lemma 4.1 we obtain*

$$\int_0^T E(t) dt \leq C \left[E(T) + \int_{\Sigma_1} (|g(u_t)|^2 + |u_t|^2) d\Sigma + C_T \int_Q |u|^2 dQ + \int_Q |u|^{2(\rho+1)} dQ + \int_Q |u|^{\rho+2} dQ \right]. \tag{4.12}$$

Next, we are going to estimate the two last terms of the right hand side of (4.12).

Estimate for $I_1 := \int_0^T \int_{\Omega} |u|^{\rho+2} dx dt$.

Applying the interpolation inequality,

$$\|y\|_p \leq \|y\|_2^\alpha \|y\|_q^{1-\alpha}; \quad \frac{1}{p} = \frac{\alpha}{2} + \frac{(1-\alpha)}{q}, \quad \alpha \in [0, 1] \tag{4.13}$$

for L^p spaces, with $p = \rho + 2$ and $\alpha = 1/\rho + 2$, we obtain for all $t \geq 0$

$$\|u(t)\|_{\rho+2} \leq \|u(t)\|_2^{1/(\rho+2)} \|u(t)\|_q^{(\rho+1)/(\rho+2)}, \quad \text{where } q = 2(\rho + 1).$$

Then, considering μ the imbedding constant of the immersion $H_{\Gamma_0}^1(\Omega) \hookrightarrow L^{2(\rho+1)}(\Omega)$, we get

$$\|u(t)\|_{\rho+2}^{\rho+2} \leq C \frac{\mu^{2(\rho+1)}}{2\varepsilon} \|u(t)\|_2^2 + \frac{\varepsilon}{2C} \|\nabla u(t)\|_2^{2(\rho+1)},$$

for all $\varepsilon > 0$ and $C = \frac{\rho}{(\rho+1)} [2(\rho + 2)\rho^{-1}E(0)]^\rho$. Considering inequality (2.8), and integrating over $(0, T)$, we obtain

$$I_1 \leq \varepsilon \int_0^T E(t) dt + C(\varepsilon, E(0)) \int_0^T \|u(t)\|_2^2 dt, \quad \text{for all } \varepsilon > 0. \tag{4.14}$$

Estimate for $I_2 := 2 \int_0^T \|u(t)\|_{2(\rho+1)}^{2(\rho+1)} dt$.

Since $0 < \rho < \frac{2}{n-2}$, if $n \geq 3$, we are going to consider a positive constant s in order to have $0 < s < \frac{2n}{n-2} - 2(\rho + 1)$ and the interpolation inequality (4.13) with $p = 2(\rho + 1)$ and $q = 2(\rho + 1) + s$, verifying, for all $t \geq 0$,

$$\|u(t)\|_{2(\rho+1)} \leq \|u(t)\|_2^{1-\alpha} \|u(t)\|_{2(\rho+1)+s}^\alpha, \tag{4.15}$$

where $0 < \alpha < 1$ is given by $\alpha = 1 + \frac{s}{(\rho+1)[2-2(\rho+1)-s]}$.

Observing the choice of s we have that $2(\rho + 1) + s < \frac{2n}{n-2}$, which implies that $H_{\Gamma_0}^1(\Omega) \hookrightarrow L^{2(\rho+1)+s}$. If β is the imbedding constant of this immersion, we obtain from (4.15)

$$\|u(t)\|_{2(\rho+1)}^{2(\rho+1)} \leq \|u(t)\|_2^{2(1-\alpha)(\rho+1)} \beta^{2\alpha(\rho+1)} \|\nabla u(t)\|_2^{2\alpha(\rho+1)}. \tag{4.16}$$

From Young's inequality we have, for all $\varepsilon > 0$ and $k > 0$, that

$$ab \leq \frac{a^p}{[\varepsilon/k]^{p/p'} p} + \frac{b^{p'} [\varepsilon/k]}{p'}, \quad \text{where } p, p' > 1 \text{ and } \frac{1}{p} + \frac{1}{p'} = 1.$$

Applying the above inequality with $a = \beta^{2\alpha(\rho+1)}\|u(t)\|_2^{2(1-\alpha)(\rho+1)}$, $b = \|\nabla u(t)\|_2^{2\alpha(\rho+1)+1}$, $p = \frac{1}{(1-\alpha)(\rho+1)}$ and $p' = \frac{1}{1-(1-\alpha)(\rho+1)}$, where α is given in (4.15), we obtain

$$\begin{aligned} & \|u(t)\|_{2(\rho+1)}^{2(\rho+1)} \\ & \leq \frac{\beta^{2\alpha(1-\alpha)^{-1}[(1-\alpha)(\rho+1)]}}{p[\varepsilon/k]^{\frac{1-(1-\alpha)(\rho+1)}{(1-\alpha)(\rho+1)}}} \|u(t)\|_2^2 + \frac{\varepsilon}{kp'} \|\nabla u(t)\|_2^{[2\alpha(\rho+1)][1-(1-\alpha)(\rho+1)]^{-1}}. \end{aligned} \tag{4.17}$$

Since $\frac{2\alpha(\rho+1)}{1-(1-\alpha)(\rho+1)} = 2 + \frac{2\rho}{1-(1-\alpha)(\rho+1)}$, it follows from (4.17) that

$$\|u(t)\|_{2(\rho+1)}^{2(\rho+1)} \leq C(\varepsilon, E(0))\|u(t)\|_2^2 + 2\varepsilon E(t), \tag{4.18}$$

where

$$C(\varepsilon, E(0)) = \frac{\beta^{2\alpha(1-\alpha)^{-1}(1-\alpha)(\rho+1)}}{p[\varepsilon/k]^{\frac{1-(1-\alpha)(\rho+1)}{(1-\alpha)(\rho+1)}}}$$

and

$$k = \frac{\rho+2}{\rho p'} \left[\frac{2(\rho+2)}{\rho} E(0) \right]^{\frac{2[\alpha(\rho+1)+1]}{2[2-(1-\alpha)(\rho+1)]}}.$$

Integrating (4.18) over $(0, T)$, we have

$$I_2 \leq 2\varepsilon \int_0^T E(t) dt + C(\varepsilon, E(0)) \int_0^T \|u(t)\|_2^2 dt, \quad \forall \varepsilon > 0. \tag{4.19}$$

Replacing (4.14) and (4.19) in (4.12) and considering $\varepsilon > 0$ sufficiently small we conclude that

$$\int_0^T E(t) dt \leq C(E(0)) \left[E(T) + \int_{\Sigma_1} (|g(u_t)|^2 + |u_t|^2) d\Gamma dt + C_T \int_Q |u|^2 dx dt \right]. \tag{4.20}$$

The next result presents an inequality where the lower order terms on the right hand side of (4.20) will be absorbed.

Lemma 4.3. *Under the hypotheses of Theorem 2.1 and considering (u, u') the solution of (1.1) with regular initial data $\{u^0, u^1\}$, we have*

$$\int_0^T \int_{\Omega} |u|^2 dx dt \leq C(E(0)) \left\{ \int_0^T \int_{\Gamma_1} (g(u'))^2 d\Gamma dt + \int_0^T \int_{\Gamma_1} |u'|^2 d\Gamma dt \right\}, \tag{4.21}$$

where $T > T_0$ and T_0 is sufficiently large.

Proof. We will argue by contradiction. Let us suppose that (4.21) is not verified and let $\{u_k(0), u'_k(0)\}$ be a sequence of initial data where the corresponding solutions $\{u_k\}_{k \in \mathbb{N}}$ of (*) with $E_k(0)$ uniformly bounded in k , verifies

$$\lim_{k \rightarrow +\infty} \frac{\int_0^T \int_{\Omega} |u_k|^2 dx dt}{\int_0^T \int_{\Gamma_1} |g(u'_k)|^2 d\Gamma dt + \int_0^T \int_{\Gamma_1} |u'_k|^2 d\Gamma dt} = +\infty. \tag{4.22}$$

Consequently, there exists $M > 0$ such that $E_k(t) \leq M, \forall k \in \mathbb{N}, \forall t \geq 0$; since E_k is a non-increasing function.

Then, we obtain a subsequence, still denoted by $\{u_k\}$ which verifies

$$u_k \rightharpoonup u \text{ weakly in } H^1(Q) \quad \text{and} \tag{4.23}$$

$$u_k \rightharpoonup u \text{ weak star in } L^\infty(0, T; H^1_{\Gamma_0}(\Omega)),$$

$$u'_k \rightharpoonup u' \text{ weak star in } L^\infty(0, T; L^2(\Omega)) \quad \text{and} \tag{4.24}$$

$$u'_k \rightharpoonup u' \text{ weakly in } L^2(0, T; L^2(\Gamma)).$$

Applying compactness results we deduce that

$$u_k \rightarrow u \text{ strongly in } L^2(0, T; L^2(\Omega)) \quad \text{and} \tag{4.25}$$

$$u_k \rightarrow u \text{ strongly in } L^2(0, T; L^2(\Gamma)).$$

In what follows we are going to use the ideas contained in Lasiecka and Tataru [15], applied to our context. Let us assume that $u \neq 0$. According to (4.25) we have that

$$|u_k|^\rho u_k \rightarrow |u|^\rho u \text{ a.e. in } \Omega \times]0, T[.$$

We conclude by Lions' Lemma that

$$|u_k|^\rho u_k \rightharpoonup |u|^\rho u \text{ weakly in } L^2(0, T; L^2(\Omega)). \tag{4.26}$$

The term $\int_0^T \int_\Omega |u_k|^2 dxdt$ is bounded since $E_k(t) \leq M; \forall k \in \mathbb{N}, \forall t \geq 0$ and $\|u_k(t)\|_2^2 \leq CE_k(t)$, where C is a positive constant independent of k and t . Consequently, from (4.22) the term

$$\int_0^T \int_{\Gamma_1} (g(u'_k))^2 d\Gamma dt + \int_0^T \int_{\Gamma_1} |u'_k|^2 d\Gamma dt \rightarrow 0 \quad \text{as } k \rightarrow +\infty.$$

Particularly, it comes that

$$g(u'_k) \rightarrow 0 \text{ strongly in } L^2(0, T; L^2(\Gamma_1)). \tag{4.27}$$

Using analogous arguments we obtain from (4.22) that

$$u'_k \rightarrow 0 \text{ strongly in } L^2(0, T; L^2(\Gamma_1)). \tag{4.28}$$

Passing to the limit in the equation, when $k \rightarrow +\infty$, we get for u ,

$$\begin{aligned} u_{tt} - \Delta u &= |u|^\rho u \quad \text{in } \Omega \times]0, T[\\ \partial_\nu u = 0, u_t &= 0 \quad \text{on } \Gamma_1 \times]0, T[\\ u &= 0 \quad \text{on } \Gamma_0 \times]0, T[; \end{aligned} \tag{4.29}$$

and for $u_t = v$,

$$\begin{aligned} v_{tt} - \Delta v &= (\rho + 1)|u|^\rho v \quad \text{in } \Omega \times]0, T[\\ \partial_\nu v = 0, v &= 0 \quad \text{on } \Gamma_1 \times]0, T[\\ v &= 0 \quad \text{on } \Gamma_0 \times]0, T[. \end{aligned}$$

We observe that $(\rho + 1)|u|^\rho \in L^\infty(0, T; L^n(\Omega))$, since $u \in L^\infty(0, T; H^1_{\Gamma_0}(\Omega))$. Then, using the results of [15] (based on Ruiz arguments [25]) adapted to our case, we conclude that $v \equiv 0$, that is $u_t \equiv 0$, for T suitably big.

Returning to (4.29) we obtain the following elliptic equation for u

$$\begin{cases} -\Delta u = |u|^\rho u & \text{in } \Omega \\ u = 0 & \text{on } \Gamma_0 \\ \partial_\nu u = 0 & \text{on } \Gamma_1. \end{cases}$$

Multiplying by u the above equation, we have a contradiction from the definition of J given in (2.3).

Let us assume that $u \equiv 0$. Defining

$$c_k = \left[\int_0^T \int_\Omega |u_k|^2 dxdt \right]^{1/2} \quad \text{and} \quad \bar{u}_k = \frac{1}{c_k} u_k, \tag{4.30}$$

we obtain,

$$\int_0^T \int_\Omega |\bar{u}_k|^2 dxdt = \int_0^T \int_\Omega \frac{|u_k|^2}{c_k^2} = \frac{1}{c_k^2} \int_0^T \int_\Omega |u_k|^2 dxdt = 1. \tag{4.31}$$

Besides, from (2.7) we deduce that

$$\bar{E}_k(t) \leq \frac{1}{c_k^2} C(\rho) E_k(t), \quad \text{where } C(\rho) = \frac{\rho + 2}{\rho} > 1. \tag{4.32}$$

Also,

$$\bar{E}_k(t) \geq \frac{1}{c_k^2} C(\rho)^{-1} E_k(t). \tag{4.33}$$

In addition, as $u = 0$, we have that $c_k \rightarrow 0$ as $k \rightarrow +\infty$.

On the other hand, integrating (4.3) over $[0, T]$, we obtain

$$\int_0^T E(t) dt \geq E(0)T - T \int_S \int_{\Gamma_1} g(u')u' d\Gamma dt. \tag{4.34}$$

From (4.34) and (4.20) we conclude

$$\begin{aligned} TE(T) \leq TE(0) \leq C(E(0)) \left\{ \int_0^T \int_{\Gamma_1} |g(u')|^2 d\Gamma dt + \int_0^T \int_{\Gamma_1} |u'|^2 d\Gamma dt \right. \\ \left. + E(T) + \int_0^T \int_\Omega |u|^2 dxdt \right\} + T \int_0^T \int_{\Gamma_1} |g(u')||u'| d\Gamma dt, \end{aligned}$$

which implies for T sufficiently large that

$$E(t) \leq C_T(E(0)) \left\{ \int_0^T \int_{\Gamma_1} |g(u')|^2 d\Gamma dt + \int_0^T \int_{\Gamma_1} |u'|^2 d\Gamma dt + \int_0^T \int_\Omega |u|^2 dxdt \right\}. \tag{4.35}$$

Applying inequality (4.35) to the solution u_k and dividing both sides by $\int_0^T \int_\Omega |u_k|^2 dxdt$, we have, for every $t \in [0, T]$,

$$\frac{E_k(t)}{\int_0^T \int_\Omega |u_k|^2 dxdt} \leq C(T) \left\{ \frac{\int_S^T \int_{\Gamma_1} |g(u'_k)|^2 d\Gamma dt + \int_0^T \int_{\Gamma_1} |u'_k|^2 d\Gamma dt}{\int_0^T \int_\Omega |u_k|^2 dxdt} + 1 \right\}. \tag{4.36}$$

From (4.22) we deduce that

$$\lim_{k \rightarrow +\infty} \frac{\int_0^T \int_{\Gamma_1} |g(u'_k)|^2 d\Gamma dt + \int_0^T \int_{\Gamma_1} |u'_k|^2 d\Gamma dt}{\int_0^T \int_\Omega |u_k|^2 dxdt} = 0 \tag{4.37}$$

and, consequently, there exists $M > 0$ such that

$$\|\nabla \bar{u}_k(t)\|_2^2 + \|\bar{u}'_k(t)\|_2^2 \leq 2C(\rho)C(T)(M + 1), \tag{4.38}$$

for all $t \in [0, T]$ and $k \in \mathbb{N}$.

Then, in particular, for a subsequence $\{\bar{u}_k\}$, we obtain

$$\bar{u}_k \rightharpoonup \bar{u} \quad \text{weak star in } L^\infty(0, T; H^1_{\Gamma_0}(\Omega)), \tag{4.39}$$

$$\bar{u}'_k \rightharpoonup \bar{u}' \quad \text{weak star in } L^\infty(0, T; L^2(\Omega)), \tag{4.40}$$

$$\bar{u}_k \rightarrow \bar{u} \quad \text{strongly in } L^2(0, T; L^2(\Omega)). \tag{4.41}$$

In addition, \bar{u}_k satisfies the equation

$$\begin{aligned} \bar{u}''_k - \Delta \bar{u}_k &= |u_k|^\rho \bar{u}_k \quad \text{in } \Omega \times]0, T[\\ \bar{u}_k &= 0 \quad \text{on } \Gamma_0 \times]0, T[\\ \partial_\nu \bar{u}_k + c_k^{-1} g(u'_k) &= 0 \quad \text{on } \Gamma_1 \times]0, T[. \end{aligned} \tag{4.42}$$

From (4.37) we obtain

$$\frac{g(u'_k)}{c_k} \rightarrow 0 \quad \text{in } L^2(0, T; L^2(\Gamma_1)) \quad \text{as } k \rightarrow +\infty. \tag{4.43}$$

According to the fact that the function $F(s) = |s|^\rho$ is continuous in \mathbb{R} and $M_\varepsilon = \sup_{|x| \leq \varepsilon} |F(x)|$ is well defined, we obtain

$$\int_0^T \int_\Omega ||u_k|^\rho \bar{u}_k|^2 dxdt \leq M_\varepsilon^2 \|\bar{u}_k\|_{L^2(Q)}^2 + c_k^{2\rho} \|\bar{u}_k\|_{L^{2\rho+2}(Q)}^{2\rho+2}.$$

From (4.38) $\{\bar{u}_k\}$ is bounded in $L^\infty(0, T; H^1_{\Gamma_0}(\Omega)) \hookrightarrow L^\infty(0, T; L^{2\rho+2}(\Omega))$ and, consequently, there exists $A > 0$ such that

$$\int_0^T \int_\Omega ||u_k|^\rho \bar{u}_k|^2 dxdt \leq A \left[M_\varepsilon^2 + c_k^{2\rho} \right].$$

Then, taking $\varepsilon \rightarrow 0$ and $k \rightarrow +\infty$ we conclude that

$$|u_k|^\rho \bar{u}_k \rightarrow 0 \quad \text{in } L^2(0, T; L^2(\Omega)) \quad \text{as } k \rightarrow +\infty. \tag{4.44}$$

Passing to the limit in (4.42) as $k \rightarrow +\infty$, taking (4.43) and (4.44) into account, and considering $v = \bar{u}'$ we deduce

$$\begin{aligned} v'' - \Delta v &= 0 && \text{in } \Omega \times]0, T[\\ v &= 0 && \text{on } \Gamma_0 \times]0, T[\\ \partial_\nu v &= 0 && \text{on } \Gamma_1 \times]0, T[. \end{aligned}$$

Applying standard uniqueness results (see Ruiz [25]) it comes that $v = \bar{u}' = 0$. Then, we obtain

$$\begin{cases} \Delta \bar{u} = 0 & \text{in } \Omega \\ \bar{u} = 0 & \text{on } \Gamma_0 \\ \partial_\nu \bar{u} = 0 & \text{on } \Gamma_1. \end{cases}$$

Multiplying the above equation by \bar{u} , we obtain a contradiction. So, Lemma 4.3 is proved. □

Combining (4.20) with Lemma 4.3 we obtain the following result.

Lemma 4.4. *For a suitably large $T > 0$, the regular solutions of problem (1.1) verifies*

$$E(T) \leq C(T, E(0)) \int_{\Sigma_1} (|g(u_t)|^2 + |u_t|^2) d\Sigma, \tag{4.45}$$

where $E(t)$ is the energy associated to problem (1.1).

Proof. From (4.20) and (4.21) we conclude that

$$T E(T) \leq C(E(0)) \left[E(T) + C_T \int_{\Sigma_1} (|g(u_t)|^2 + |u_t|^2) d\Sigma \right].$$

Then,

$$[T - C(E(0))]E(T) \leq C(T, E(0)) \int_{\Sigma_1} (|g(u_t)|^2 + |u_t|^2) d\Sigma$$

and for $T > 0$ big enough we get the desired result. □

From the above lemma we complete the proof of Theorem 2.1 following the same steps contained in the work of Lasiecka and Tataru [15].

Acknowledgements. The authors would like to thank Irena Lasiecka for suggesting us to study this problem during the 3rd ISAAC Congress in Berlin and her fruitful comments. The authors wish to thank Professor Djairo and all the organizers for their kind attention and the nice moments during the 5th Workshop on Nonlinear Differential Equations.

References

- [1] H. Brézis, *Analyse Fonctionnelle: Théorie et Applications*, Masson, Paris, 1983.
- [2] H. Brézis, *Opérateurs Maximal Monotones et Semi-Groupes de Contractions dans les espaces de Hilbert*, Amsterdam, North-Holland, 1973.
- [3] V. Barbu, *Nonlinear Semigroups and Differential Equations in Banach Spaces*, Noordhoff, 1976.
- [4] M. M. Cavalcanti, V. N. Domingos Cavalcanti and P. Martinez, *Existence and decay rate estimates for the wave equation with nonlinear boundary damping and source term*, J. Differential Equations **203** (2004), 119-158.
- [5] I. Chueshov, M. Eller and I. Lasiecka, *On the attractor for a semilinear wave equation with critical exponent and nonlinear boundary dissipation*, Comm. Partial Differential Equations **27**(9-10) (2002), 1901-1951.
- [6] G. Chen and H. Wong, *Asymptotic Behaviour of solutions of the one Dimensional Wave Equation with a Nonlinear Boundary Stabilizer*, SIAM J. Control and Opt. **27** (1989), 758-775.
- [7] Y. Ebihara, M. Nakao and T. Nambu, *On the existence of global classical solution of initial boundary value problem for $u'' - \Delta u - u^3 = f$* , Pacific J. of Math. **60** (1975), 63-70.
- [8] V. Georgiev and G. Todorova, *Existence of a solution of the wave equation with nonlinear damping and source terms*, J. Diff. Equat. **109** (1975), 63-70.
- [9] R. Ikehata, *Some remarks on the wave equation with nonlinear damping and source terms*, Nonlinear Analysis T.M.A. **27** (1996), 1165-1175.
- [10] R. Ikehata and T. Matsuyama, *On global solutions and energy decay for the wave equations of Kirchhoff type with nonlinear damping terms*, J. Math. Anal. Appl. **204** (1996), 729-753.
- [11] R. Ikehata and T. Suzuki, *Stable and unstable sets for evolution equations of parabolic and hyperbolic type*, Hiroshima Math. J. **26** (1996), 475-491.
- [12] H. Ishii, *Asymptotic stability and blowing up of solutions of some nonlinear equations*, J. Diff. Equations **26** (1977), 291-319.
- [13] V. Komornik and E. Zuazua, *A Direct Method for Boundary Stabilization of the Wave Equation*, J. math. Pures et Appl. **69** (1990), 33-54.
- [14] V. Komornik, *Exact Controllability and Stabilization. The Multiplier Method*, Mason-John Wiley, Paris, 1994.
- [15] I. Lasiecka and D. Tataru, *Uniform Boundary Stabilization of Semilinear Wave Equations with Nonlinear Boundary Damping*, Differential and Integral Equations **6**(3) (1993), 507-533.
- [16] I. Lasiecka and R. Triggiani, *Uniform stabilization of the wave equation with Dirichlet or Neumann feedback control without geometric conditions*, Appl. Math. Optim. **25** (1992), 189-124.
- [17] H. A. Levine and L. E. Payne, *Nonexistence theorems for the heat equation with nonlinear boundary conditions and for the porous medium equation backward in time*, J. Differential Equations **16** (1974), 319-334.
- [18] H. A. Levine and J. Serrin, *Global nonexistence theorems for quasilinear evolution equations with dissipation*, Arch. Rational Mech. Anal. **137** (1997), 341-361.

- [19] H. A. Levine and A. Smith, *A potential well theory for the wave equation with a nonlinear boundary condition*, J. Reine Angew. Math. **374** (1987), 1-23.
- [20] J. L. Lions, *Quelques Méthodes de Résolution des Problèmes aux Limites Non Linéaires*, Dunod, Paris, 1969.
- [21] J. L. Lions and E. Magenes, *Problèmes aux Limites non Homogènes, Applications*, Dunod, Paris, 1968, Vol. 1.
- [22] P. Martinez, *A new method to obtain decay rate estimates for dissipative systems*, ESAIM: Control, Optimisation and Calculus of Variations **4** (1999), 419-444.
- [23] K. Mochizuki and T. Motai, *On energy decay problems for wave equations with nonlinear dissipation term in \mathbf{R}^n* , J. Math. Soc. Japan **47** (1995), 405-421.
- [24] M. Nakao and K. Ono, *Existence of global solutions to the Cauchy problem for semi-linear dissipative wave equations*, Math. A. **214** (1993) 325-342.
- [25] A. Ruiz, *Unique continuation for weak solutions of the wave equation plus a potential*, J. Math. Pures Appl. **71** (1992) 455-467.
- [26] J. Serrin, G. Todorova and E. Vitillaro, *Existence for a nonlinear wave equation with nonlinear damping and source terms* Differential and Integral Equations **16**(1) (2003), 13-50.
- [27] D. H. Sattiger, *On global solutions of nonlinear hyperbolic equations*, Arch. Rat. Mech. Anal. **30**, 148-172.
- [28] R. Showalter, *Monotone Operators in Banach Spaces and Nonlinear Partial Differential Equations*, AMS Providence, 1997.
- [29] M. Tsutsumi, *Existence and non existence of global solutions for nonlinear parabolic equations*, Publ. RIMS, Kyoto Univ. **8** (1972/73), 211-229.
- [30] E. Vitillaro, *A potential well method for the wave equation with nonlinear source and boundary damping terms*, Glasgow Mathematical Journal **44** (2002), 375-395.
- [31] E. Vitillaro, *Some new results on global nonexistence and blow-up for evolution problems with positive initial energy*, Rend. Istit. Mat. Univ. Trieste **31** (2000), 245-275.
- [32] E. Vitillaro, *Global existence for the wave equation with nonlinear boundary damping and source terms*, J. Differential Equations **186** (2002), 259-298.

M.M. Cavalcanti, V.N. Domingos Cavalcanti and J.A. Soriano

Departamento de Matemática

Universidade Estadual de Maringá

87020-900 Maringá – PR

Brasil

e-mail: mmcavalcanti@uem.br

vndcavalcanti@uem.br

jaspalomino@uem.br

Multiscale Asymptotic Behavior of a Solution of the Heat Equation on \mathbb{R}^N

Thierry Cazenave, Flávio Dickstein and Fred B. Weissler

Abstract. In this paper, we construct solutions $e^{t\Delta}u$ of the heat equation on \mathbb{R}^N , where $u \in C_0(\mathbb{R}^N)$, which have nontrivial asymptotic properties on different time scales. More precisely, for all $0 < \sigma < N$, we consider the set $\omega^\sigma(u)$ of limit points in $C_0(\mathbb{R}^N)$ as $t \rightarrow \infty$ of $t^{\frac{\sigma}{2}}e^{t\Delta}u(x\sqrt{t})$. In particular we show that, given an arbitrary countable set $S \subset (0, N)$, there exists $u \in C_0(\mathbb{R}^N)$ such that $\omega^\sigma(u) = C_0(\mathbb{R}^N)$ whenever $\sigma \in S$.

Mathematics Subject Classification (2000). 35K05, 35B40.

Keywords. Heat equation, asymptotic behavior, decay rate.

1. Introduction

The purpose of this paper is to investigate the long-time asymptotic behavior of $e^{t\Delta}u$, where $u \in C_0(\mathbb{R}^N)$ and $(e^{t\Delta})_{t \geq 0}$ is the heat semigroup. It is a continuation of our previous article [1], where we consider initial values u such that

$$|\cdot|^\sigma u(\cdot) \in L^\infty(\mathbb{R}^N), \quad (1.1)$$

for a fixed $0 < \sigma < N$. Since (1.1) implies $\sup_{t > 0} t^{\frac{\sigma}{2}} \|e^{t\Delta}u\|_{L^\infty} < \infty$, it is natural to study the long-time asymptotic behavior of $e^{t\Delta}u$ after a rescaling, i.e. we study the set of limit points of $t^{\frac{\sigma}{2}}e^{t\Delta}u(x\sqrt{t})$ as $t \rightarrow \infty$. This notion is formalized by defining, for $u \in C_0(\mathbb{R}^N)$ and $0 < \sigma < N$,

$$\omega^\sigma(u) = \{f \in C_0(\mathbb{R}^N); \exists t_n \rightarrow \infty \text{ s.t. } D_{\sqrt{t_n}}^\sigma e^{t_n \Delta} u \xrightarrow[n \rightarrow \infty]{} f \text{ in } L^\infty(\mathbb{R}^N)\}, \quad (1.2)$$

where the dilation D_λ^σ is given by

$$D_\lambda^\sigma u(x) = \lambda^\sigma u(\lambda x). \quad (1.3)$$

In [1], for initial values satisfying (1.1), we characterize $\omega^\sigma(u)$ in terms of the asymptotic structure of u under the group $(D_\lambda^\sigma)_{\lambda > 0}$. (See section 2 below for a summary of some of the results from [1].) Our present goal is to study $u \in C_0(\mathbb{R}^N)$ for which $\omega^\sigma(u)$ is nontrivial for more than one value of σ . This requires that,

unlike in [1], we specifically do not impose the condition (1.1) in order to define $\omega^\sigma(u)$. Indeed, if $u \in C_0(\mathbb{R}^N)$ satisfies (1.1), then $\omega^\mu(u) = \{0\}$ for all $0 < \mu < \sigma$. Thus u cannot satisfy the condition (1.1) for both $\sigma = \sigma_1$ and $\sigma = \sigma_2$ if $\omega^{\sigma_1}(u)$ and $\omega^{\sigma_2}(u)$ are both nontrivial. Clearly, then, we need to study $\omega^\sigma(u)$ without assuming the condition (1.1).

Our long term goal is to characterize for arbitrary $u \in C_0(\mathbb{R}^N)$ the collection of sets $\omega^\sigma(u)$ for all $0 < \sigma < N$ in terms of spatial asymptotic properties of u . Unfortunately, at the current stage of our research, we have not obtained general results of this nature. On the other hand, we have been able to construct specific examples of $u \in C_0(\mathbb{R}^N)$ for which the collection of sets $\omega^\sigma(u)$ has a surprising structure. In this paper, we present two closely related examples of this type. See [2] and [3] for two other examples.

Theorem 1.1. *Fix $0 \leq \sigma < N$. For any sequence $(\mu_m)_{m \geq 0} \subset (\sigma, N)$, there exists a function u with the following properties.*

- (i) $u \in C_0(\mathbb{R}^N) \cap C^\infty(\mathbb{R}^N)$ and $|\cdot|^\sigma u \in L^\infty(\mathbb{R}^N)$.
- (ii) $\omega^\mu(u) = \{0\}$ for all $0 < \mu \leq \sigma$. (This property is vacuous if $\sigma = 0$.)
- (iii) $\omega^{\mu_m}(u) = C_0(\mathbb{R}^N)$ for every $m \geq 0$.

Theorem 1.2. *Fix $M > 0$ and $0 < \sigma < N$. For any sequence $(\mu_m)_{m \geq 0} \subset (\sigma, N)$, there exists a function u with the following properties.*

- (i) $u \in C_0(\mathbb{R}^N) \cap C^\infty(\mathbb{R}^N)$ and $|u(x)| \leq M|x|^{-\sigma}$ for all $x \in \mathbb{R}^N$.
- (ii) $\omega^\mu(u) = \{0\}$ for all $0 < \mu < \sigma$.
- (iii) $\omega^\sigma(u) = e^\Delta \{v \in L^1_{loc}(\mathbb{R}^N); \|\cdot\|^\sigma v\|_{L^\infty} \leq M\}$.
- (iv) $\omega^{\mu_m}(u) = C_0(\mathbb{R}^N)$ for every $m \geq 0$.

In order to describe the construction used in the proofs of Theorems 1.1 and 1.2, we first observe that for $0 < \sigma < N$,

$$\omega^\sigma(u) = \bigcap_{t>0} \overline{\bigcup_{s \geq t} \{D_{\sqrt{t}}^\sigma e^{t\Delta} u\}}, \tag{1.4}$$

where the closure in (1.4) is in the L^∞ norm. In particular, $\omega^\sigma(u)$ is a (possibly empty) closed subset of $C_0(\mathbb{R}^N)$. Thus, to show that $\omega^\sigma(u) = C_0(\mathbb{R}^N)$ for a given value of σ , it suffices to prove that $\omega^\sigma(u)$ contains a dense subset of $C_0(\mathbb{R}^N)$. Furthermore, since $D_{\sqrt{t}}^\sigma e^{t\Delta} = e^\Delta D_{\sqrt{t}}^\sigma$ (which can be verified by an easy calculation), it follows that

$$\omega^\sigma(u) = \{f \in C_0(\mathbb{R}^N); \exists \lambda_n \rightarrow \infty \text{ s.t. } e^\Delta D_{\lambda_n}^\sigma u \xrightarrow{n \rightarrow \infty} f \text{ in } L^\infty(\mathbb{R}^N)\}. \tag{1.5}$$

This suggests that the conclusions of Theorem 1.1 or 1.2 can be achieved by constructing u for which the set of possible limits of $D_{\lambda_n}^{\mu_m} u$ along sequences $\lambda_n \rightarrow \infty$ is sufficiently large. We are thus led to define, for $0 < \sigma < N$ and $u \in C_0(\mathbb{R}^N)$,

$$\Omega^\sigma(u) = \{z \in L^1_{loc}(\mathbb{R}^N); \exists \lambda_n \rightarrow \infty \text{ s.t. } D_{\lambda_n}^\sigma u \rightarrow z \text{ in } \mathcal{D}'(\mathbb{R}^N \setminus \{0\})\}. \tag{1.6}$$

The basic idea of the proofs of Theorems 1.1 and 1.2 is to let u be an infinite sum of functions whose supports are disjoint spherical shells around the origin increasingly far away. These functions are rescaled versions of functions z_k which

we explicitly exhibit as limits in (1.6). Since the z_k constitute a countable set, a density argument is then needed.

The functions used to prove Theorems 1.1 and 1.2, while clearly not the same, are closely related. It turns out to be convenient to define two auxiliary functions U and V such that in Theorem 1.1 $u = U$ and in Theorem 1.2 $u = M(U + V)$.

As mentioned above, in the papers [2] and [3], we also construct functions $u \in C_0(\mathbb{R}^N)$ for which the sets $\omega^\sigma(u)$ have a prescribed structure similar to that in Theorems 1.1 and 1.2. On the other hand, the constructions in those papers differ fundamentally from the current paper. More precisely, in [2] and [3], we construct u such that the limits of $D_{\lambda_n}^\mu(u)$ are distributions supported at the origin rather than functions on \mathbb{R}^N .

The paper is organized as follows. In the next section, we recall some of the results from [1] which are essential to the proofs of Theorems 1.1 and 1.2. In Section 3, we define the auxiliary functions U and V . In Section 4, we study the action of the dilations D_λ^μ on the functions U and V and prove Theorems 1.1 and 1.2.

2. Basic facts about $\omega^\sigma(u)$ and $\Omega^\sigma(u)$

In this section, we recall the results from [1] which we use in the proofs of Theorems 1.1 and 1.2. The rest of this paper is self-contained, i.e. no further reference to [1] is made.

Lemma 2.1. *Let $0 < \sigma < N$ and let $(u_n)_{n \geq 0} \subset L^1_{loc}(\mathbb{R}^N)$ satisfy*

$$\sup_{n \geq 0} \| |\cdot|^\sigma u_n \|_{L^\infty} < \infty. \tag{2.1}$$

If $u_n \rightarrow u$ in $\mathcal{D}'(\mathbb{R}^N \setminus \{0\})$ for some $u \in L^1_{loc}(\mathbb{R}^N)$, then $|\cdot|^\sigma u \in L^\infty(\mathbb{R}^N)$ and $\| |\cdot|^\sigma u \|_{L^\infty} \leq \limsup_{n \rightarrow \infty} \| |\cdot|^\sigma u_n \|_{L^\infty}$.

Proof. Since $u_n \rightarrow u$ in $\mathcal{D}'(\mathbb{R}^N \setminus \{0\})$, we deduce that $|\cdot|^\sigma u_n \rightarrow |\cdot|^\sigma u$ in the sense of $\mathcal{D}'(\mathbb{R}^N \setminus \{0\})$. The result follows from the weak* compactness of the unit closed ball of $L^\infty(\mathbb{R}^N)$. □

Proposition 2.2. *Let $0 < \sigma < N$ and let $(u_n)_{n \geq 0} \subset C_0(\mathbb{R}^N)$ satisfy (2.1). If $u_n \rightarrow u$ in $\mathcal{D}'(\mathbb{R}^N \setminus \{0\})$ for some $u \in L^1_{loc}(\mathbb{R}^N)$, then $|\cdot|^\sigma u \in L^\infty(\mathbb{R}^N)$ and $e^{\Delta} u_n \rightarrow e^{\Delta} u$ in $C_0(\mathbb{R}^N)$.*

Proof. It follows from Lemma 2.1 that $|\cdot|^\sigma u \in L^\infty(\mathbb{R}^N)$. The result is then an application of Propositions 2.1 (i) and 3.8 (i) in [1]. □

Proposition 2.3. *Let $0 < \sigma < N$, let $u \in C_0(\mathbb{R}^N)$ be such that $|\cdot|^\sigma u \in L^\infty(\mathbb{R}^N)$, and let $\Omega^\sigma(u)$ be defined by (1.6).*

- (i) *If $z \in \Omega^\sigma(u)$, then $\| |\cdot|^\sigma z \|_{L^\infty} \leq \| |\cdot|^\sigma u \|_{L^\infty}$.*
- (ii) *If $(z_n)_{n \geq 0} \subset \Omega^\sigma(u)$ and $z_n \rightarrow z$ in $\mathcal{D}'(\mathbb{R}^N \setminus \{0\})$ for some $z \in L^1_{loc}(\mathbb{R}^N)$, then $z \in \Omega^\sigma(u)$.*

(iii) $\omega^\sigma(u) = e^\Delta \Omega^\sigma(u)$, where $\omega^\sigma(u)$ is defined by (1.4).

Proof. Since $\| |\cdot|^\sigma D_\lambda^\sigma u \|_{L^\infty} = \| |\cdot|^\sigma u \|_{L^\infty}$, property (i) follows from Lemma 2.1. Next, we deduce from property (i) and Proposition 2.1 (i) in [1] that $\Omega^\sigma(u)$ defined by (1.6) coincides with $\Omega^\sigma(u)$ defined by formula (2.5) in [1]. Property (ii) is then a consequence of the closedness of $\Omega^\sigma(u)$ (see Remark 2.4 (iii) and Proposition 2.1 (i) in [1]); and property (iii) follows from Theorem 1.1 in [1]. \square

3. The auxiliary functions U and V

In this section we construct two auxiliary functions U and V which will be used in the definitions of the functions described in Theorems 1.1 and 1.2. The notation we establish below will also be used in the next section.

Let the sequence $(\phi_n)_{n \geq 0} \subset C_c^\infty(\mathbb{R}^N)$ be weak* dense in the closed unit ball of $L^\infty(\mathbb{R}^N)$. (Recall that the closed unit ball of $L^\infty(\mathbb{R}^N)$ with the weak* topology is compact and metrizable.) In particular,

$$\|\phi_n\|_{L^\infty} \leq 1. \tag{3.1}$$

Let $(\psi_n)_{n \geq 0} \subset C_c^\infty(\mathbb{R}^N)$ be a weak* sequentially dense sequence in $L^\infty(\mathbb{R}^N)$ (i.e., for each $f \in L^\infty(\mathbb{R}^N)$ there exists a sequence n_k such that $\psi_{n_k} \rightarrow f$ weak*). Without loss of generality, we may assume that

$$\|\psi_n\|_{L^\infty} \leq n. \tag{3.2}$$

Let the sequence $(a_n)_{n \geq 1}$ be defined by induction by

$$a_1 = 1, \quad a_{n+1} = e^{a_n}, \tag{3.3}$$

for all $n \geq 1$. It follows easily that

$$a_n \geq n, \quad a_{n+1} \geq a_n^n, \tag{3.4}$$

for all $n \geq 1$. We deduce in particular that

$$a_{n+1} - a_n > 2, \tag{3.5}$$

for all $n \geq 2$. Next, let $(\rho_n)_{n \geq 1} \subset C_c^\infty(\mathbb{R}^N)$ satisfy

$$0 \leq \rho_n \leq 1, \tag{3.6}$$

$$\text{supp } \rho_n \subset \{a_{2n+1} < |x| < a_{2n+2}\}, \tag{3.7}$$

$$\rho_n(x) = 1 \text{ on } \{a_{2n+1} + 1 \leq |x| \leq a_{2n+2} - 1\}, \tag{3.8}$$

for all $n \geq 1$. (Note that (3.8) is possible by (3.5).) Fix

$$0 \leq \sigma < N. \tag{3.9}$$

Consider a sequence $(\mu_m)_{m \geq 0}$ as in Theorem 1.1 or 1.2. Clearly, it suffices to prove Theorem 1.1 (or Theorem 1.2) for a sequence $(\mu'_m)_{m \geq 0}$ which includes every element of the sequence $(\mu_m)_{m \geq 0}$. Thus we may assume that the sequence

$$(\mu_m)_{m \geq 0} \subset (\sigma, N), \tag{3.10}$$

is dense in (σ, N) and we may re-order and repeat elements of the sequence μ_m if necessary. In particular, we may assume without loss of generality that

$$\mu_m - \sigma \geq \frac{1}{\sqrt{m+2}}, \tag{3.11}$$

for all $m \geq 0$.

Next, we observe that any integer $p \geq 0$ can be uniquely written in the form

$$p = \ell(\ell + 1)/2 + m \quad \text{with} \quad 0 \leq m \leq \ell. \tag{3.12}$$

We define the functions $\mathbf{l}, \mathbf{m} : \mathbb{N} \cup \{0\} \rightarrow \mathbb{N} \cup \{0\}$ by

$$\mathbf{l}(p) = \ell, \quad \mathbf{m}(p) = m \quad \text{with } \ell \text{ and } m \text{ given by (3.12)}. \tag{3.13}$$

Also, we define the function $\mathbf{p} : (\mathbb{N} \cup \{0\})^2 \rightarrow \mathbb{N} \cup \{0\}$ by

$$\mathbf{p}(m, \ell) = \ell(\ell + 1)/2 + m, \tag{3.14}$$

so that

$$\mathbf{l}(\mathbf{p}(m, \ell)) = \ell, \quad \mathbf{m}(\mathbf{p}(m, \ell)) = m \quad \text{for all } 0 \leq m \leq \ell, \tag{3.15}$$

by (3.13)–(3.14). We now set

$$\beta_n = \sqrt{a_{2n+1}a_{2n+2}} \tag{3.16}$$

for all $n \geq 1$ and

$$\varphi_k(x) = |x|^{-\mu_{\mathbf{m}(k)}} \psi_{\mathbf{l}(k)} \left(\frac{x}{\beta_{2k}} \right) \rho_{2k}(x), \tag{3.17}$$

$$\theta_k(x) = |x|^{-\sigma} \phi_{\mathbf{l}(k)} \left(\frac{x}{\beta_{2k+1}} \right) \rho_{2k+1}(x), \tag{3.18}$$

for all $k \geq 1$.

Lemma 3.1. *Assume (3.9) and (3.11). If $(\varphi_k)_{k \geq 1}$ and $(\theta_k)_{k \geq 1}$ are given by (3.17) and (3.18), then the following properties hold.*

- (i) $\varphi_k, \theta_k \in C_c^\infty(\mathbb{R}^N)$.
- (ii) $\text{supp } \varphi_k \subset \{a_{4k+1} < |x| < a_{4k+2}\}$, $\text{supp } \theta_k \subset \{a_{4k+3} < |x| < a_{4k+4}\}$.
- (iii) $\| |\cdot|^\sigma \varphi_k \|_{L^\infty} \leq a_{4k}^{-\sqrt{k}}$, $\| |\cdot|^\sigma \theta_k \|_{L^\infty} \leq 1$.
- (iv) $\| \varphi_k \|_{L^\infty} \leq a_{4k}^{-\sqrt{k}}$, $\| \theta_k \|_{L^\infty} \leq a_{4k+3}^{-\sigma}$.

Proof. (i) and (ii) are immediate. To prove (iii), we note that on $\text{supp } \varphi_k$,

$$|x|^\sigma |x|^{-\mu_{\mathbf{m}(k)}} \leq a_{4k+1}^{-\mu_{\mathbf{m}(k)} - \sigma} \leq a_{4k+1}^{-\frac{1}{\sqrt{\mathbf{m}(k)+2}}} \leq a_{4k+1}^{-\frac{1}{\sqrt{k+2}}} \leq a_{4k}^{-\frac{4k}{\sqrt{k+2}}} \leq a_{4k}^{-2\sqrt{k}},$$

by (ii), (3.11) and (3.4); and so,

$$\| |\cdot|^\sigma \varphi_k \|_{L^\infty} \leq a_{4k}^{-2\sqrt{k}} \mathbf{l}(\mathbf{m}(k)) \leq k a_{4k}^{-2\sqrt{k}} \leq a_{4k}^{-\sqrt{k}},$$

where we used (3.2), (3.4) and (3.6). This proves the first statement in (iii). The second statement in (iii) is an immediate consequence of (3.1) and (3.6). Finally, property (iv) follows from (ii) and (iii). \square

Lemma 3.2. *Assume (3.9) and (3.11). If*

$$U = \sum_{k=1}^{\infty} \varphi_k, \quad V = \sum_{k=1}^{\infty} \theta_k, \tag{3.19}$$

then the following properties hold.

- (i) $U, V \in C^\infty(\mathbb{R}^N)$.
- (ii) $\text{supp } U \cap \text{supp } V = \emptyset$.
- (iii) $|\cdot|^\sigma U \in C_0(\mathbb{R}^N)$ and $\| |\cdot|^\sigma U \|_{L^\infty} \leq 1$.
- (iv) $|\cdot|^\sigma V \in L^\infty(\mathbb{R}^N)$ and $\| |\cdot|^\sigma V \|_{L^\infty} \leq 1$.

Proof. By property (ii) of Lemma 3.1, the φ_k 's and θ_k 's have disjoint supports. In particular, the definition (3.19) makes sense and properties (i) and (ii) are immediate. Properties (iii) and (iv) follow from property (iii) of Lemma 3.1. \square

4. Proof of Theorems 1.1 and 1.2

In this section we prove Theorems 1.1 and 1.2. First, however, we need several lemmas concerning the action of dilations on the functions U and V defined in the previous section.

Lemma 4.1. *Let $(\lambda_j)_{j \geq 1}$ be a sequence such that*

$$\lambda_j \xrightarrow{j \rightarrow \infty} \infty. \tag{4.1}$$

Let $n'(j), n''(j) \in \mathbb{N}$ satisfy

$$a_{4n'(j)+3} \leq \lambda_j \leq a_{4n''(j)}, \tag{4.2}$$

for all sufficiently large j and set

$$U_j = \sum_{k \leq n'(j)} \varphi_k + \sum_{k \geq n''(j)} \varphi_k =: U'_j + U''_j.$$

It follows that

$$\|e^\Delta D_{\lambda_j}^\mu U_j\|_{L^\infty} \xrightarrow{j \rightarrow \infty} 0, \tag{4.3}$$

for every $0 < \mu < N$.

Proof. By Lemma 3.1, U'_j is supported in $\{1 \leq |x| \leq a_{4n'(j)+2}\}$ and $\|U'_j\|_{L^\infty} \leq 1$. Thus

$$\|D_{\lambda_j}^\mu U'_j\|_{L^1} = \lambda_j^{-(N-\mu)} \|U'_j\|_{L^1} \leq C \lambda_j^{-(N-\mu)} a_{4n'(j)+2}^N \xrightarrow{j \rightarrow \infty} 0, \tag{4.4}$$

by (4.1), (4.2) and (3.4). Next, it follows from Lemma 3.1 that

$$\|D_{\lambda_j}^\mu U''_j\|_{L^\infty} = \lambda_j^\mu \|U''_j\|_{L^\infty} \leq C \lambda_j^\mu a_{4n''(j)}^{-\sqrt{n''(j)}} \xrightarrow{j \rightarrow \infty} 0, \tag{4.5}$$

by (4.1), (4.2) and (3.4). The estimate (4.3) follows from (4.4)–(4.5). \square

Lemma 4.2. *Let $0 < \sigma < N$ and suppose $(\lambda_j)_{j \geq 1}$ satisfies (4.1). Let $m'(j), m''(j) \in \mathbb{N}$ satisfy*

$$a_{4m'(j)+5} \leq \lambda_j \leq a_{4m''(j)+2}, \tag{4.6}$$

for all sufficiently large j and set

$$V_j = \sum_{k \leq m'(j)} \theta_k + \sum_{k \geq m''(j)} \theta_k =: V'_j + V''_j.$$

It follows that

$$\|e^\Delta D_{\lambda_j}^\mu V_j\|_{L^\infty} \xrightarrow{j \rightarrow \infty} 0, \tag{4.7}$$

for every $0 < \mu < N$.

Proof. By Lemma 3.1, V'_j is supported in $\{1 \leq |x| \leq a_{4m'(j)+4}\}$ and $\|V'_j\|_{L^\infty} \leq 1$. Thus

$$\|D_{\lambda_j}^\mu V'_j\|_{L^1} = \lambda_j^{-(N-\mu)} \|V'_j\|_{L^1} \leq C \lambda_j^{-(N-\mu)} a_{4m'(j)+4}^N \xrightarrow{j \rightarrow \infty} 0, \tag{4.8}$$

by (4.1), (4.6) and (3.4). Next, it follows from Lemma 3.1 that

$$\|D_{\lambda_j}^\mu V''_j\|_{L^\infty} = \lambda_j^\mu \|V''_j\|_{L^\infty} \leq C \lambda_j^\mu a_{4m''(j)+3}^{-\sigma} \xrightarrow{j \rightarrow \infty} 0, \tag{4.9}$$

by (4.1), (4.6) and (3.4). The estimate (4.7) follows from (4.8)-(4.9). \square

Fix $0 \leq m \leq \ell$ and set

$$k(j) = \mathbf{p}(\mathbf{p}(m, \ell), j) = \frac{j(j+1)}{2} + \mathbf{p}(m, \ell), \tag{4.10}$$

for all $j \geq 0$. Note that if $j \geq \mathbf{p}(m, \ell)$, then

$$\mathbf{l}(\mathbf{m}(k(j))) = \mathbf{l}(\mathbf{p}(m, \ell)) = \ell, \quad \mathbf{m}(\mathbf{m}(k(j))) = \mathbf{m}(\mathbf{p}(m, \ell)) = m, \tag{4.11}$$

by (3.13) and (3.15).

Lemma 4.3. *Fix $0 \leq m \leq \ell$ and let $k(j)$ be defined by (4.10). If*

$$\lambda_j = \beta_{2k(j)}, \tag{4.12}$$

with β_n given by (3.16), then

$$e^\Delta D_{\lambda_j}^{\mu_m} U \xrightarrow{j \rightarrow \infty} e^\Delta (|\cdot|^{-\mu_m} \psi_\ell), \tag{4.13}$$

in $C_0(\mathbb{R}^N)$, where U is defined by (3.19).

Proof. It follows from (4.11) and (3.17) that for $j \geq \mathbf{p}(m, \ell)$,

$$\varphi_{k(j)}(x) = |x|^{-\mu_m} \psi_\ell \left(\frac{x}{\beta_{2k(j)}} \right) \rho_{2k(j)}(x);$$

and so,

$$D_{\lambda_j}^{\mu_m} \varphi_{k(j)}(x) = |x|^{-\mu_m} \psi_\ell(x) \rho_{2k(j)}(\lambda_j x). \tag{4.14}$$

In particular, we see that

$$\sup_{j \geq \mathbf{p}(m, \ell)} \|\cdot\|^{-\mu_m} D_{\lambda_j}^{\mu_m} \varphi_{k(j)}\|_{L^\infty} \leq \|\psi_\ell\|_{L^\infty} < \infty. \tag{4.15}$$

Moreover, it follows from (4.14) and (3.8) that

$$D_{\lambda_j}^{\mu_m} \varphi_{k(j)}(x) = |x|^{-\mu_m} \psi_\ell(x),$$

on

$$\frac{a_{4k(j)+1} + 1}{\beta_{2k(j)}} \leq |x| \leq \frac{a_{4k(j)+2} - 1}{\beta_{2k(j)}}.$$

Since

$$\frac{a_{4k(j)+1} + 1}{\beta_{2k(j)}} \xrightarrow{j \rightarrow \infty} 0, \quad \frac{a_{4k(j)+2} - 1}{\beta_{2k(j)}} \xrightarrow{j \rightarrow \infty} \infty,$$

by (3.4), we see that $D_{\lambda_j}^{\mu_m} \varphi_{k(j)} \rightarrow |\cdot|^{-\mu_m} \psi_\ell$ in $\mathcal{D}'(\mathbb{R}^N \setminus \{0\})$. We deduce from Proposition 2.2 and formula (4.15) that

$$e^\Delta D_{\lambda_j}^{\mu_m} \varphi_{k(j)} \xrightarrow{j \rightarrow \infty} e^\Delta (|\cdot|^{-\mu_m} \psi_\ell),$$

in $C_0(\mathbb{R}^N)$. Property (4.13) now follows from Lemma 4.1 applied with $\mu = \mu_m$, $n'(j) = k(j) - 1$ and $n''(j) = k(j) + 1$. \square

Lemma 4.4. *Fix $0 \leq m \leq \ell$ and let $k(j)$ be defined by (4.10). If $\sigma > 0$ and*

$$\lambda_j = \beta_{2k(j)+1},$$

with β_n given by (3.16), then

$$D_{\lambda_j}^\sigma V \xrightarrow{j \rightarrow \infty} |\cdot|^{-\sigma} \phi_\ell, \tag{4.16}$$

in $\mathcal{D}'(\mathbb{R}^N \setminus \{0\})$, where V is defined by (3.19).

Proof. It follows from (4.11) and (3.18) that for $j \geq \mathbf{p}(m, \ell)$,

$$\theta_{k(j)}(x) = |x|^{-\sigma} \phi_\ell \left(\frac{x}{\beta_{2k(j)+1}} \right) \rho_{2k(j)+1}(x);$$

and so,

$$D_{\lambda_j}^\sigma \theta_{k(j)}(x) = |x|^{-\sigma} \phi_\ell(x) \rho_{2k(j)+1}(\lambda_j x).$$

Using (3.8), we deduce that

$$D_{\lambda_j}^\sigma \theta_{k(j)}(x) = |x|^{-\sigma} \phi_\ell(x),$$

and

$$D_{\lambda_j}^\sigma \theta_i(x) = 0, \quad i \neq k(j),$$

on

$$\frac{a_{4k(j)+3} + 1}{\beta_{2k(j)+1}} \leq |x| \leq \frac{a_{4k(j)+4} - 1}{\beta_{2k(j)+1}}. \tag{4.17}$$

Therefore, $D_{\lambda_j}^\sigma V(x) = |x|^{-\sigma} \phi_\ell(x)$ on the set (4.17). The result follows, since

$$\frac{a_{4k(j)+3} + 1}{\beta_{2k(j)+1}} \xrightarrow{j \rightarrow \infty} 0, \quad \frac{a_{4k(j)+4} - 1}{\beta_{2k(j)+1}} \xrightarrow{j \rightarrow \infty} \infty,$$

by (3.4). \square

Proof of Theorem 1.1. We let $u = U$, where U is defined by (3.19).

(i) This is an immediate consequence of Lemma 3.2.

(ii) By Lemma 3.2 (iii), $|\cdot|^\mu u \in C_0(\mathbb{R}^N)$ if $0 < \mu \leq \sigma$. It follows that $\Omega^\mu(u) = \{0\}$, where $\Omega^\mu(u)$ is defined by (1.6). Therefore, $\omega^\mu(u) = \{0\}$ by Proposition 2.3 (iii).

(iii) Given any $0 \leq m \leq \ell$, we deduce from Lemma 4.3 that $e^\Delta(|\cdot|^{-\mu_m} \psi_\ell) \in \omega^{\mu_m}(u)$. Since $\omega^{\mu_m}(u)$ is a closed subset of $C_0(\mathbb{R}^N)$, property (iii) follows from Lemma 4.5 below. \square

Lemma 4.5. *Let $0 < \mu < N$ and $n_0 \in \mathbb{N}$. It follows that the set $E = e^\Delta \cup_{\ell \geq n_0} \{|\cdot|^{-\mu} \psi_\ell\}$ is dense in $C_0(\mathbb{R}^N)$.*

Proof. We claim that

$$e^\Delta \mathcal{S}(\mathbb{R}^N) \subset \overline{E}, \tag{4.18}$$

where the closure is in $C_0(\mathbb{R}^N)$. To see this, consider $f \in \mathcal{S}(\mathbb{R}^N)$ and let $g = |\cdot|^\mu f \in L^\infty(\mathbb{R}^N)$. By the choice of the ψ_n , there exists a sequence n_k such that $\psi_{n_k} \rightarrow g$ in $L^\infty(\mathbb{R}^N)$ weak*. In particular, $\psi_{n_k} \rightarrow g$ in $\mathcal{D}'(\mathbb{R}^N \setminus \{0\})$, so that $|\cdot|^{-\mu} \psi_{n_k} \rightarrow |\cdot|^{-\mu} g = f$ in $\mathcal{D}'(\mathbb{R}^N \setminus \{0\})$. Since $\sup_{k \geq 0} \| |\cdot|^{-\mu} (\cdot|^{-\mu} \psi_{n_k}) \|_{L^\infty} = \sup_{k \geq 0} \| \psi_{n_k} \|_{L^\infty} < \infty$, it follows from Proposition 2.2 that $e^\Delta(|\cdot|^{-\mu} \psi_{n_k}) \rightarrow e^\Delta f$ in $C_0(\mathbb{R}^N)$. Thus $e^\Delta f \in \overline{E}$, which proves the claim (4.18). The lemma follows since $e^\Delta \mathcal{S}(\mathbb{R}^N)$ is dense in $C_0(\mathbb{R}^N)$. (This last property is clear since $e^{-4\pi^2|\xi|^2} \mathcal{S}(\mathbb{R}^N)$ is dense in $\mathcal{S}(\mathbb{R}^N)$; and so by applying the Fourier transform, $e^\Delta \mathcal{S}(\mathbb{R}^N)$ is dense in $\mathcal{S}(\mathbb{R}^N)$ and therefore in $C_0(\mathbb{R}^N)$.) \square

Proof of Theorem 1.2. Fix $0 < \sigma < N$ and $M > 0$. We let $u = M(U + V)$, where U and V are defined by (3.19).

(i) This is an immediate consequence of Lemma 3.2.

(ii) By Lemma 3.2 (iii) and (iv), $|\cdot|^\mu u \in C_0(\mathbb{R}^N)$ if $0 < \mu < \sigma$. It follows that $\Omega^\mu(u) = \{0\}$, where $\Omega^\mu(u)$ is defined by (1.6). Therefore, $\omega^\mu(u) = \{0\}$ by Proposition 2.3 (iii).

(iii) Since $|\cdot|^\sigma U \in C_0(\mathbb{R}^N)$ by Lemma 3.2 (iii), we see that $D_\lambda^\sigma U \rightarrow 0$ in $\mathcal{D}'(\mathbb{R}^N \setminus \{0\})$ as $\lambda \rightarrow \infty$. Therefore,

$$\Omega^\sigma(u) = M\Omega^\sigma(V) \supset \bigcup_{m \geq 0} \{M|\cdot|^{-\sigma} \phi_m\},$$

where the last inclusion follows from Lemma 4.4. We deduce from Lemma 4.6 below that $\Omega^\sigma(u) = \{v \in L^1_{loc}(\mathbb{R}^N); \| |\cdot|^\sigma v \|_{L^\infty} \leq M\}$, and the result follows from Proposition 2.3 (iii).

(iv) Given any $0 \leq m \leq \ell$, let the sequence $(\lambda_j)_{j \geq 0}$ be defined by (4.12). It follows from Lemma 4.3 that $e^\Delta D_{\lambda_j}^{\mu_m} U \rightarrow e^\Delta(|\cdot|^{-\mu_m} \psi_\ell)$ in $C_0(\mathbb{R}^N)$. In addition, it follows from Lemma 4.2 (applied with $m'(j) = k(j) - 1$ and $m''(j) = k(j)$) that $e^\Delta D_{\lambda_j}^{\mu_m} V \rightarrow 0$ in $C_0(\mathbb{R}^N)$. Thus $M e^\Delta(|\cdot|^{-\mu_m} \psi_\ell) \in \omega^{\mu_m}(u)$. Property (iv) now follows from Lemma 4.5. \square

Lemma 4.6. *Let $0 < \sigma < N$ and set $F = \{v \in L^1_{loc}(\mathbb{R}^N); \|\cdot\|^{-\sigma} v\|_{L^\infty} \leq 1\}$. Consider $u \in C_0(\mathbb{R}^N) \cap F$ and let $\Omega^\sigma(u)$ be defined by (1.6). If*

$$\Omega^\sigma(u) \supset \bigcup_{m \geq 0} \{|\cdot|^{-\sigma} \phi_m\},$$

then $\Omega^\sigma(u) = F$.

Proof. Let $E = \bigcup_{m \geq 0} \{|\cdot|^{-\sigma} \phi_m\}$. It follows from Proposition 2.3 (i) that $\Omega^\sigma(u) \subset F$. To see the reverse inclusion, consider $z \in F$ and let $w = |\cdot|^\sigma z$ so that $\|w\|_{L^\infty} \leq 1$. By the choice of the ϕ_n , there exists a sequence n_k such that $\phi_{n_k} \rightarrow w$ weak* in $L^\infty(\mathbb{R}^N)$. In particular, $\phi_{n_k} \rightarrow w$ in $\mathcal{D}'(\mathbb{R}^N \setminus \{0\})$, so that $|\cdot|^{-\sigma} \phi_{n_k} \rightarrow |\cdot|^{-\sigma} w = z$ in $\mathcal{D}'(\mathbb{R}^N \setminus \{0\})$. Proposition 2.3 (ii) now implies that $z \in \Omega^\sigma(u)$. \square

References

- [1] Cazenave T., Dickstein F. and Weissler F.B. Universal solutions of the heat equation on \mathbb{R}^N , *Discrete Contin. Dynam. Systems* **9** (2003), 1105–1132.
- [2] Cazenave T., Dickstein F. and Weissler F.B. A solution of the heat equation with a continuum of decay rates, in *Elliptic and parabolic problems: A special tribute to the work of Haïm Brezis*, Progress in Nonlinear Differential Equations and their Applications **63**. Birkhäuser Verlag, Basel, 2005, 135–138.
- [3] Cazenave T., Dickstein F. and Weissler F.B. A solution of the constant coefficient heat equation on \mathbb{R} with exceptional asymptotic behavior: an explicit construction, to appear in *J. Math. Pures Appl.*

Thierry Cazenave
 Laboratoire Jacques-Louis Lions UMR CNRS 7598
 B.C. 187, Université Pierre et Marie Curie
 4, place Jussieu
 75252 Paris Cedex 05
 France
 e-mail: cazenave@ccr.jussieu.fr

Flávio Dickstein
 Instituto de Matemática
 Universidade Federal do Rio de Janeiro
 Caixa Postal 68530
 21944–970 Rio de Janeiro, R.J.
 Brazil
 e-mail: flavio@labma.ufrj.br

Fred B. Weissler
 LAGA UMR CNRS 7539
 Institut Galilée–Université Paris XIII
 99, Avenue J.-B. Clément
 93430 Villetaneuse
 France
 e-mail: weissler@math.univ-paris13.fr

Positive Solutions for a Class of Nonlocal Elliptic Problems

F.J.S.A. Corrêa and S.D.B. Menezes

Dedicated to Prof. Djairo G. de Figueiredo on occasion of his 70th birthday.

1. Introduction

During the past several decades, many authors have studied some physical phenomena formulated in nonlocal mathematical models derived from applications such as mathematical biology, chemical reactions and nonlinear vibrations, among others. See, for example, [1, 3, 4, 5] and the references therein, for more details on motivation for studying nonlocal problems.

In this work we study the elliptic nonlocal problem

$$\begin{cases} -\Delta u &= a(x, u)\|u\|_q^p & \text{in } \Omega, \\ u &> 0 & \text{in } \Omega, \\ u &= 0 & \text{on } \partial\Omega, \end{cases} \quad (1.1)$$

where $\Omega \subset \mathbb{R}^N$ is a bounded smooth domain, $a \in C(\overline{\Omega} \times \mathbb{R})$, whose properties will be timely introduced, $1 \leq q \leq \infty$ and $p > 0$. The solutions u of this problem represent steady-state solutions of the degenerate parabolic equation with a nonlocal source:

$$\begin{cases} u_t &= f(u)(\Delta u + a\|u\|_q^p) & \text{in } \Omega \times (0, \infty), \\ u(x, t) &= 0 & \text{on } \partial\Omega \times (0, \infty), \\ u(x, 0) &= u_0(x), \end{cases} \quad (1.2)$$

where a is a positive real constant and $\Omega \subset \mathbb{R}^N$ is a bounded smooth domain. We remark that $\|u\|_q$ is the usual L^q -norm in Ω .

Such a problem has been studied by Chen [6], Deng-Duan-Xie [9] and Deng-Li-Xie [10] and others, always supposing that a is a constant and by considering functions $f \in C([0, \infty)) \cap C^1((0, \infty))$, with $f > 0$ and $f' \geq 0$ on $(0, \infty)$ and so the search of its stationary solutions leads naturally to the study of (1.1). In particular, the authors in Chen [6], Deng-Duan-Xie [9] and Deng-Li-Xie [10] show that $p = 1$ is the blow-up critical exponent of the evolution problem (1.2). That is to say, if

$p < 1$, the solutions are global for all initial data while if $p > 1$, the solutions blow up for sufficiently large initial data.

Our goal in this paper is to prove existence results for positive solutions of problem (1.1) in cases $0 < p < 1$ or $p > 1$ and $1 \leq q < \frac{2N}{n-2}$ ($N \geq 3$), $1 \leq q < \infty$ ($N = 2$), and $q = \infty$ in case $N = 1$. Another situation, when $p = q = 1$, leads to a linear eigenvalue problem which will not be studied here because the techniques are quite similar to those used in the local case. We have to point out that we permit that a depends on $x \in \Omega$ and on $u \in \mathbb{R}$ which is a rather general assumption, at least in the stationary case, than those considered by the aforementioned authors.

This work is organized as follows:

- In section 2 we use a Galerkin method to show existence of a solution for problem (1.1) when $0 < p < 1$, $1 \leq q < \frac{2N}{N-2}$ ($N \geq 3$) and $1 \leq q < \infty$ ($N = 1, 2$), among other assumptions on the behavior of $a(x, t)$.
- In section 3 we use the method of sub- and supersolution to show the existence of a solution of (1.1) when $a = a(t)$ is a nondecreasing function.
- In section 4 we use a result on fixed points in a cone in order to show existence of solution in cases $N \geq 1$, $0 < p \neq 1$, $q = \infty$ or q large enough.

To conclude this introduction we have to point out that problem (1.1) has no variational structure and in view of this we had to seek other techniques. In the present case we believe that the Galerkin method and the fixed point results in cones are more appropriate to study problem (1.1).

2. First Existence Result: The Galerkin Method

In this section we will prove the following result by using the Galerkin method because, as remarked above, problem (1.1) has no variational structure and, besides of this, we do not need a-priori bounds for solutions of (1.1).

Theorem 2.1. *Problem (1.1) possesses a solution provide either (a) or (b) below is satisfied.*

- (a) $0 < p < 1$, $1 < q < \frac{2N}{N-2}$ ($n \geq 3$), $q > \beta + 1$, $\beta + p < 1$, $0 \leq a_0(x) \leq a(x, u) \leq A(x)|u|^\beta + B(x)$, $0 \neq a_0 \in L^s(\Omega)$ ($s > N$), $0 \leq B \in L^{q'}(\Omega)$, $0 \leq A \in L^{q_1'}(\Omega)$ and $q_1 = \frac{q}{\beta+1}$.
- (b) $0 < p < 1$, $1 \leq q < \infty$, $N = 1, 2$.

Proof. Before attacking problem (1.1) let us focus our attention on problem

$$\begin{cases} -\Delta u &= a(x, u)\|u\|_q^p + \lambda\phi & \text{in } \Omega, \\ u &> 0 & \text{in } \Omega, \\ u &= 0 & \text{on } \partial\Omega, \end{cases} \tag{2.1}$$

where $0 < \lambda < 1$ is a fixed parameter and $\phi > 0$ is a given function in $C_0^2(\overline{\Omega})$. In order to use the Galerkin Method let us consider the orthonormal Hilbertian

basis $\mathbb{B} = \{\varphi_1, \varphi_2, \dots\}$ in $H_0^1(\Omega)$ and the finite dimensional vector space $\mathbb{V}_m = \text{span} \{\varphi_1, \dots, \varphi_m\}$. So, if $u \in \mathbb{V}_m$, there exists $\xi = (\xi_1, \dots, \xi_m) \in \mathbb{R}^m$ such that

$$u = \sum_{j=1}^m \xi_j \varphi_j$$

and we have an isometric linear isomorphism

$$\begin{aligned} \mathbb{V}_m &\longleftrightarrow \mathbb{R}^m \\ u &\longleftrightarrow \xi \\ u = \sum_{j=1}^m \xi_j \varphi_j &\longleftrightarrow \xi = (\xi_1, \dots, \xi_m) \end{aligned}$$

with $\|u\|^2 = \int_{\Omega} |\nabla u|^2 = |\xi|^2 = \langle \xi, \xi \rangle$ where $\langle \cdot, \cdot \rangle$ is the usual Euclidian inner product in \mathbb{R}^m and $|\cdot|$ its corresponding norm. Our approach is motivated by that performed by Alves-Figueiredo [2] which relies heavily on the following result whose proof may be found in Lions [12] and is a consequence of Brouwer’s Fixed Point Theorem.

Proposition 2.1. *Let $F : \mathbb{R}^m \rightarrow \mathbb{R}^m$ be a continuous function such that $\langle F(\xi), \xi \rangle \geq 0$ on $|\xi| = r$, for some positive $r > 0$. Then, there exists $\xi_0 \in \overline{B}_r(0)$ such that $F(\xi_0) = 0$.*

In view of the above isomorphism we make, with no additional comment, the identification $u \leftrightarrow \xi$ as above.

Let

$$\begin{aligned} F : \mathbb{R}^m &\longleftrightarrow \mathbb{R}^m \\ \xi &\longmapsto F(\xi) = (F_1(\xi), \dots, F_m(\xi)), \end{aligned}$$

where

$$F_i(\xi) = \int \nabla u \nabla \varphi_i - \|u\|_q^p \int a(x, u) \varphi_i - \lambda \int \phi \varphi_i, \quad i = 1, \dots, m.$$

where \int stands for the integral on all over Ω , unless we state the contrary. Thus, in view of the orthonormality of \mathbb{B} , one has

$$F_i(\xi) = \xi_i - \|u\|_q^p \int a(x, u) \varphi_i - \lambda \int \phi \varphi_i, \quad i = 1, \dots, m.$$

and so

$$\langle F(\xi), \xi \rangle = \|u\|^2 - \|u\|_q^p \int a(x, u) u - \lambda \int \phi u.$$

We now begin to distinguish the several possibilities related to the values of p and q .

Case (a). $1 < q < \frac{2N}{N-2}$, $N \geq 3$, $\beta + 1 < q$, $0 < \lambda < 1$ and $0 < p < 1$

Because $a(x, u) \leq A(x)|u|^\beta + B(x)$ one has

$$\int a(x, u) u \leq \int a(x, u) |u| \leq \int A(x) |u|^{\beta+1} + \int B(x) |u|$$

where $\frac{1}{q_1} + \frac{1}{q_1} = 1$, $H_0^1(\Omega) \subset L^{q_1}(\Omega)$, $q_1(\beta + 1) = q$, $1 < q_1 < q < \frac{2N}{N-2}$ in case $N \geq 3$, and $\int \phi u \leq C\|\phi\|_2\|u\|$. Since

$$\int A(x)|u|^{\beta+1} \leq \left(\int A^{q_1'}\right)^{1/q_1'} \left(\int |u|^{(\beta+1)q_1}\right)^{1/q_1} = \|A\|_{q_1'}\|u\|_q^{\beta+1}$$

and

$$\int B(x)u \leq \int B(x)|u| \leq \|B\|_{q'}\|u\|_q$$

we have

$$\langle F(\xi), \xi \rangle \geq \|u\|^2 - C\|A\|_{q_1'}\|u\|^{p+\beta+1} - C\|B\|_{q'}\|u\|^{p+1} - C\|\phi\|_2\|u\|.$$

In view of $0 < p < 1$ and $p + \beta < 1$ there is a sufficiently large $r > 0$, r does not depend on m , such that

$$\langle F(\xi), \xi \rangle > 0, \text{ if } |\xi| = r.$$

By virtue of this there exists $(\xi^{(m)} \in \mathbb{R}^m \longleftrightarrow u_m \in \mathbb{V}_m)$, $|\xi^{(m)}| = \|u_m\| \leq r$ satisfying

$$\int \nabla u_m \nabla \varphi_i = \|u_m\|_q^p \int a(x, u_m(x))\varphi_i + \lambda \int \phi \varphi_i, \quad i = 1, \dots, m. \tag{2.2}$$

We have to point out that such an approximating solution u_m depends on λ , too. From (2.2),

$$\int \nabla u_m \nabla \varphi = \|u_m\|_q^p \int a(x, u_m(x))\varphi + \lambda \int \phi \varphi, \text{ for all } \varphi \in \mathbb{V}_m. \tag{2.3}$$

Let us fix $k \leq m$, $\mathbb{V}_k \subset \mathbb{V}_m$. For a fixed $\varphi \in \mathbb{V}_k$, we may take $m \rightarrow \infty$ in equation (2.3) and so, in view of the boundedness of $(\|u_m\|)$,

$$\begin{aligned} u_m &\rightharpoonup u && \text{in } H_0^1(\Omega), \\ u_m &\rightarrow u && \text{in } L^q(\Omega), \quad 1 < q < \frac{2N}{N-2} \\ u_m(x) &\rightarrow u(x) && \text{a.e. in } \Omega, \\ \|u_m\|_q &\rightarrow \|u\|_q. \end{aligned}$$

Thus

$$\int \nabla u \nabla \varphi = \|u\|_q^p \int a(x, u(x))\varphi + \lambda \int \phi \varphi, \text{ for all } \varphi \in \mathbb{V}_k. \tag{2.4}$$

Since k is arbitrary,

$$\int \nabla u \nabla \varphi = \|u\|_q^p \int a(x, u(x))\varphi + \lambda \int \phi \varphi, \text{ for all } \varphi \in H_0^1(\Omega). \tag{2.5}$$

As we pointed out before $u = u_\lambda$ and so

$$\begin{cases} -\Delta u_\lambda = a(x, u_\lambda(x))\|u_\lambda\|_q^p + \lambda\phi & \text{in } \Omega, \\ u_\lambda = 0 & \text{on } \partial\Omega. \end{cases} \tag{2.6}$$

Since $\lambda > 0$ and $\phi > 0$ in Ω one has

$$\begin{cases} -\Delta u_\lambda \geq a(x, u_\lambda(x))\|u_\lambda\|_q^p & \text{in } \Omega, \\ u_\lambda = 0 & \text{on } \partial\Omega. \end{cases}$$

In view of the maximum principle $u_\lambda > 0$ in Ω and so $\|u_\lambda\|_q^p > 0$ which yields

$$\begin{cases} -\Delta \left(\frac{u_\lambda}{\|u_\lambda\|_q^p} \right) \geq a_0(x) & \text{in } \Omega, \\ \frac{u_\lambda}{\|u_\lambda\|_q^p} = 0 & \text{on } \partial\Omega. \end{cases}$$

Let ω be the only positive solution of

$$\begin{cases} -\Delta\omega = a_0(x) & \text{in } \Omega, \\ \omega = 0 & \text{on } \partial\Omega. \end{cases}$$

Because

$$\begin{cases} -\Delta \left(\frac{u_\lambda}{\|u_\lambda\|_q^p} \right) \geq -\Delta\omega & \text{in } \Omega, \\ \frac{u_\lambda}{\|u_\lambda\|_q^p} = \omega = 0 & \text{on } \partial\Omega, \end{cases}$$

and thanks to the maximum principle

$$\frac{u_\lambda}{\|u_\lambda\|_q^p} \geq \omega \text{ in } \Omega,$$

which implies

$$\|u_\lambda\|_q \geq \|\omega\|_q^{1-p} > 0, \text{ for all } \lambda \in (0, 1).$$

Since $0 < p < 1$ one has that $\|u_\lambda\|_q$ is bounded from below by $\|\omega\|_q^{1-p}$ which is a constant that does not depend on $\lambda \in (0, 1)$.

Take $\lambda = 1/n$, $n = 1, 2, \dots$ and set $u_{\frac{1}{n}} = u_n$ to obtain

$$\int \nabla u_n \nabla \varphi = \|u_n\|_q^p \int a(x, u_n(x))\varphi + \frac{1}{n} \int \phi\varphi, \text{ for all } \varphi \in H_0^1(\Omega). \tag{2.7}$$

For $\varphi = u_n$

$$\|u_n\|^2 = \|u_n\|_q^p \int a(x, u_n) + \frac{1}{n} \int \phi u_n, \text{ for all } n = 1, 2, \dots$$

↓

$$\|u_n\|^2 \leq C\|u_n\|^{p+1} + C\|\phi\|_2\|u_n\|, \text{ for all } n \in \mathbb{N}$$

and so $(\|u_n\|)$ is a bounded sequence. Reasoning as before

$$u_n \rightharpoonup u \text{ in } H_0^1(\Omega), \quad u_n \rightarrow u \text{ in } L^q(\Omega)$$

which yields

$$\int \nabla u \nabla \varphi = \|u\|_q^p \int a(x, u(x))\varphi, \text{ for all } \varphi \in H_0^1(\Omega).$$

Since $\|u_n\|_q \geq \|\omega\|_q^{1-p}$ we have $\|u\|_q \geq \|\omega\|_q^{1-p} > 0$ and so we get a nontrivial solution of problem (1.1).

The case (b) is proved analogously and in view of this we will omit its proof. □

Remark 2.1. If $p = 1$ the only solution of problem (1.1) is the trivial one, provided a is sufficiently small. Indeed, let u be a solution of (1.1). So

$$\int |\nabla u|^2 = \|u\|_q \int a(x)u \leq \|a\|_\infty \|u\|_q |\Omega|^{\frac{1}{q'}} \|u\|_q$$

which implies

$$\|u\|^2 \leq C|\Omega|^{1/q'} \|a\|_\infty \|u\|^2.$$

Consequently, $u = 0$ if $\|a\|_\infty < \frac{1}{C|\Omega|^{1/q'}}$.

Remark 2.2. We remark that problem (1.1) possesses at most one nontrivial solution if a does not depend on u . Indeed, suppose that both u and v are nontrivial solutions of

$$\begin{cases} -\Delta u &= a(x)\|u\|_q^p & \text{in } \Omega, \\ u &= 0 & \text{on } \partial\Omega, \end{cases} \tag{2.8}$$

Consequently, $\|u\|_q = \|v\|_q$ and so

$$\begin{cases} -\Delta u &= -\Delta v & \text{in } \Omega, \\ u &= 0 & \text{on } \partial\Omega, \end{cases}$$

which yields, by uniqueness, that $u = v$.

Remark 2.3. If the function a depends only on $x \in \Omega$, problem (1.1) may be easily solved. Indeed, suppose that $0 \neq a = a(x) \in L^q(\Omega), 1 \leq q \leq \infty$, and let $v \in W^{2,q}(\Omega)$ be the only solution of

$$\begin{cases} -\Delta v &= a(x) & \text{in } \Omega, \\ v &= 0 & \text{on } \partial\Omega, \end{cases}$$

and set $u = \|v\|_q^{\frac{p}{1-p}} v$, with $p \neq 1$. So

$$\begin{cases} -\Delta u &= a(x, u)\|u\|_q^p & \text{in } \Omega, \\ u &> 0 & \text{in } \Omega, \\ u &= 0 & \text{on } \partial\Omega. \end{cases}$$

In this case we also have uniqueness.

3. The Second Existence Result: The Subsolution and Supersolution Method

In this section we study problem (1.1) by using the sub- and supersolution method. We will continue supposing that $a \in C(\overline{\Omega} \times \mathbb{R})$ and we have the following result.

Theorem 3.1. *Suppose that $a(x, t_1) \leq a(x, t_2)$ if $t_1 \leq t_2$ and $x \in \Omega$. Furthermore suppose that there are functions $\underline{u}, \overline{u} \in C(\overline{\Omega})$, $\underline{u}, \overline{u}$ which are, respectively, sub and supersolution of (1.1), with $\underline{u}(x) \leq \overline{u}(x), \forall x \in \overline{\Omega}$. Then problem (1.1) possesses a solution u satisfying $\underline{u} \leq u \leq \overline{u}$.*

Proof. Let us begin by remarking that \underline{u}, \bar{u} satisfy

$$\begin{cases} -\Delta \underline{u} \leq a(x, \underline{u}) \|\underline{u}\|_q^p & \text{in } \Omega, \\ \underline{u} = 0 & \text{on } \partial\Omega, \end{cases} \tag{3.1}$$

and

$$\begin{cases} -\Delta \bar{u} \leq a(x, \bar{u}) \|\bar{u}\|_q^p & \text{in } \Omega, \\ \bar{u} = 0 & \text{on } \partial\Omega. \end{cases} \tag{3.2}$$

As usual we define $u_0 = \underline{u}$ and inductively we define a sequence of functions (u_n) belonging to $C(\bar{\Omega})$ as

$$\begin{cases} -\Delta u_{n+1} = a(x, u_n) \|u_n\|_q^p & \text{in } \Omega, \\ u_{n+1} = 0 & \text{on } \partial\Omega. \end{cases} \tag{3.3}$$

A standard calculation shows that $u_0 \leq u_n \leq u_{n+1} \leq \bar{u}$ and so there is a function $u(x) = \lim_{n \rightarrow \infty} u_n(x)$. It is clear that u_j is continuous for all $j \in \mathbb{N}$ and $\|u_j\|_q^p \leq \|\bar{u}\|_q^p$.

In view of (3.3) one has

$$\begin{aligned} a(\cdot, u_n(\cdot)) \|u_n\|_q^p &\in L^q(\Omega), 1 \leq q \leq \infty, \\ 0 \leq a(x, u_n(x)) \|u_n\|_q^p &\leq a(x, \bar{u}(x)) \|\bar{u}\|_q^p \leq C, \forall x \in \Omega, \end{aligned}$$

and so

$$\|u_{n+1}\|_q \leq C, \forall 1 \leq n < +\infty.$$

Taking $q > N$ we have $u_n \rightarrow u$ in $C^1(\bar{\Omega})$ and because of (3.3) we obtain

$$\int_{\Omega} \nabla u_{n+1} \cdot \nabla \varphi = \|u_n\|_q^p \int_{\Omega} a(x, u_n) \varphi, \forall \varphi \in C_0^1(\bar{\Omega}).$$

and so

$$\int_{\Omega} \nabla u \cdot \nabla \varphi = \|u\|_q^p \int_{\Omega} a(x, u) \varphi, \forall \varphi \in C_0^1(\bar{\Omega}).$$

which implies that $u \in C_0^1(\bar{\Omega})$ is a weak solution of problem (1.1) which completes the proof of our theorem. □

Example 3.1. We now give an example in which the above result applies. Let $\varphi_1 > 0, \|\varphi_1\|_q = 1$ be an eigenfunction of the Laplacian, under Dirichlet boundary conditions, associated to the first eigenvalue λ_1 , that is,

$$\begin{aligned} -\Delta \varphi_1 &= \lambda_1 \varphi_1 & \text{in } \Omega, \\ \varphi_1 &= 0 & \text{in } \partial\Omega. \end{aligned}$$

We now suppose that $a = a(t) \geq \lambda_1 t$, for all $t \geq 0$. In this case

$$\begin{aligned} -\Delta \varphi_1 &\leq a(\varphi_1) \|\varphi_1\|_q^p & \text{in } \Omega, \\ \varphi_1 &= 0 & \text{in } \partial\Omega. \end{aligned}$$

which implies that $\underline{u} = \varphi_1$ is a subsolution for the problem

$$\begin{cases} -\Delta u = a(u) \|u\|_q^p & \text{in } \Omega, \\ u > 0 & \text{in } \Omega, \\ u = 0 & \text{on } \partial\Omega. \end{cases} \tag{3.4}$$

Let us construct a supersolution. In this way, let us consider an operator $S : C^0(\bar{\Omega}) \rightarrow C^0(\bar{\Omega})$ which, for each $u \in C^0(\bar{\Omega})$ associates a function $v \in C^0(\bar{\Omega})$, the unique solution of the problem

$$\begin{cases} -\Delta v = a(u)\|u\|_q^p + \lambda_1\varphi_1 & \text{in } \Omega, \\ v > 0 & \text{in } \Omega, \\ v = 0 & \text{on } \partial\Omega. \end{cases} \tag{3.5}$$

It is a standard matter to show that this operator is well defined and compact and we may use the Schaefer Fixed Point Theorem – see [8] – to show that S possesses a fixed point \bar{u} which is a solution of

$$\begin{cases} -\Delta \bar{u} = a(\bar{u})\|\bar{u}\|_q^p + \lambda_1\varphi_1 & \text{in } \Omega, \\ \bar{u} > 0 & \text{in } \Omega, \\ \bar{u} = 0 & \text{on } \partial\Omega. \end{cases} \tag{3.6}$$

Furthermore,

$$\begin{cases} -\Delta \bar{u} \geq a(\bar{u})\|\bar{u}\|_q^p & \text{in } \Omega, \\ \bar{u} > 0 & \text{in } \Omega, \\ \bar{u} = 0 & \text{on } \partial\Omega, \end{cases} \tag{3.7}$$

because λ_1 and φ_1 are positive. The same reason leads us to

$$\begin{cases} -\Delta \bar{u} \geq \lambda_1\varphi_1 & \text{in } \Omega, \\ \bar{u} > 0 & \text{in } \Omega, \\ \bar{u} = 0 & \text{on } \partial\Omega, \end{cases} \tag{3.8}$$

and the maximum principle implies that $\bar{u} \geq \varphi_1 = \underline{u}$. Consequently, in view of the above result, problem (3.4) possesses a solution u satisfying $\underline{u} = \varphi_1 \leq u \leq \bar{u}$.

4. The Third Existence Result: A Fixed Point in a Cone

In this section we will consider the cases in which $q = \infty$ or q is large enough, $N \geq 1$ and $0 < p \neq 1$. At first we consider the unidimensional case and, after that, we study the case $N \geq 2$ by searching for radial solutions. We use the fixed point theorem below, due to Guo-Lakshmikantham [11]:

Theorem 4.1. *Let E be a Banach space, and let $P \subset E$ be a cone in E . Let Ω_1 and Ω_2 be two bounded open sets in E such that $0 \in \Omega_1$ and $\bar{\Omega}_1 \subset \Omega_2$. Let $S : P \cap (\bar{\Omega}_2/\Omega_1) \rightarrow P$ be a completely continuous operator. Suppose that one of the conditions*

(C₁) $\|Sx\| \leq \|x\|$ for all $x \in P \cap \partial\Omega_1$ and $\|Sx\| \geq \|x\|$ for all $x \in P \cap \partial\Omega_2$

(C₂) $\|Sx\| \geq \|x\|$ for all $x \in P \cap \partial\Omega_1$ and $\|Sx\| \leq \|x\|$ for all $x \in P \cap \partial\Omega_2$

is satisfied. Then S has at least one fixed point in $P \cap (\bar{\Omega}_2/\Omega_1)$.

We prove an existence result for the problem

$$\begin{cases} -u''(t) = a(t, u)\|u\|_q^p, & 0 < t < 1, \\ u'(0) = u(1) = 0, \end{cases} \tag{4.1}$$

where $a \in C([0, 1] \times \mathbb{R})$, $a \geq 0$, $a \not\equiv 0$ in $[0, 1] \times \mathbb{R}$ and $q = \infty$ or q is large enough. We observe that if u is a solution of (4.1), we may extend it, by symmetry, on the whole interval $[-1, 1]$ to obtain a solution of the two point boundary value problem

$$\begin{cases} -u''(t) &= a(t, u)\|u\|_q^p, \quad -1 < t < 1, \\ u(-1) &= u(1) = 0. \end{cases}$$

Theorem 4.2. *If $a \in C([0, 1] \times \mathbb{R})$, $0 < a_0 \leq a(t, u) \leq a_\infty$ in $[0, 1] \times \mathbb{R}$, $0 < p < 1$ or $p > 1$ and $q = \infty$, then problem (4.1) possesses a positive solution.*

Proof. First of all we remark that the Green function of the problem

$$\begin{cases} -u''(t) &= g(t), \quad 0 < t < 1, \\ u'(0) &= u(1) = 0, \end{cases}$$

where $g \in C([0, 1])$ is given by

$$G(s, t) = \begin{cases} 1 - t, & 0 \leq s \leq t \leq 1, \\ 1 - s, & 0 \leq t \leq s \leq 1. \end{cases}$$

First suppose that $q = \infty$. Thus, $\varphi \in C([0, 1])$ is a solution of (4.1) if, and only if,

$$\varphi(t) = S\varphi(t) = \|\varphi\|_\infty^p \int_0^1 a(s, \varphi(s))G(t, s)ds.$$

Let $E = C([0, 1])$ endowed with the sup-norm. If

$$E^+ = \{\varphi \in C([0, 1]); \varphi \geq 0 \text{ in } [0, 1]\},$$

it is a standard matter to show that $S : E^+ \rightarrow E^+$ is a completely continuous operator. In E we consider the cone

$$P = \left\{ \varphi \in E : \varphi \geq 0 \text{ and } \min_{t \in [0, b]} \varphi(t) \geq (1 - b)\|\varphi\|_\infty \right\},$$

where b is a given number in the open interval $(0, 1)$.

Let us show that $S(P) \subset P$. Indeed, we will prove that $\varphi \geq 0$ implies $S\varphi \in P$. For, we adapt to our case a device which is explored in Stańczy [14]. If $\varphi \geq 0$ we have

$$\begin{aligned}
 & \min_{0 \leq t \leq b} \int_0^1 \|\varphi\|_\infty^p a(s, \varphi(s)) G(t, s) ds \\
 &= \min_{0 \leq t \leq b} \|\varphi\|_\infty^p \left(\int_0^t (1-t)a(s, \varphi(s)) ds + \int_t^1 (1-s)a(s, \varphi(s)) ds \right) \\
 &\geq \min_{0 \leq t \leq b} \|\varphi\|_\infty^p \left(\int_0^t (1-b)a(s, \varphi(s)) ds + \int_t^1 (1-s)a(s, \varphi(s)) ds \right) \\
 &\geq \min_{0 \leq t \leq b} \|\varphi\|_\infty^p \left(\int_0^t (1-b)(1-s)a(s, \varphi(s)) ds + \int_t^1 (1-b)(1-s)a(s, \varphi(s)) ds \right) \\
 &= (1-b) \min_{0 \leq t \leq b} \|\varphi\|_\infty^p \left(\int_0^t (1-s)a(s, \varphi(s)) ds + \int_t^1 (1-s)a(s, \varphi(s)) ds \right) \\
 &= (1-b) \min_{0 \leq t \leq b} \|\varphi\|_\infty^p \int_0^1 (1-s)a(s, \varphi(s)) ds \\
 &= (1-b) \|\varphi\|_\infty^p \int_0^1 (1-s)a(s, \varphi(s)) ds \\
 &= (1-b) \max_{0 \leq t \leq 1} \|\varphi\|_\infty^p \left(\int_0^t (1-s)a(s, \varphi(s)) ds + \int_t^1 (1-s)a(s, \varphi(s)) ds \right) \\
 &\geq (1-b) \max \|\varphi\|_\infty^p \left(\int_0^t (1-t)a(s, \varphi(s)) ds + \int_t^1 (1-s)a(s, \varphi(s)) ds \right) \\
 &= (1-b) \max_{0 \leq t \leq 1} \|\varphi\|_\infty^p \int_0^1 a(s, \varphi(s)) G(t, s) ds = (1-b) \|S\varphi\|_\infty
 \end{aligned}$$

and so

$$\min_{0 \leq t \leq b} S\varphi(t) \geq (1-b) \|S\varphi\|_\infty \Rightarrow S\varphi \in P.$$

Hence, the solution operator S is well defined from P into itself. Let us first consider the case $0 < p < 1$. Note that

$$S\varphi(t) = \|\varphi\|_\infty^p \int_0^1 a(s, \varphi(s)) G(t, s) ds \leq a_\infty \|\varphi\|_\infty^p.$$

Since $0 < p < 1$ one has $t^{1-p} \rightarrow \infty$ as $t \rightarrow \infty$ which implies that there exists $R_2 > 0$, R_2 large enough, such that

$$\begin{aligned}
 & \|\varphi\|_\infty^{1-p} \geq a_\infty \text{ if } \|\varphi\|_\infty = R_2 \\
 & \Downarrow \\
 & \|\varphi\|_\infty \geq a_\infty \|\varphi\|_\infty^p \text{ if } \|\varphi\|_\infty = R_2 \\
 & \Downarrow \\
 & S\varphi(t) \leq \|\varphi\|_\infty \text{ if } \|\varphi\|_\infty = R_2 \\
 & \Downarrow \\
 & \|S\varphi\|_\infty \leq \|\varphi\|_\infty \text{ if } \|\varphi\|_\infty = R_2.
 \end{aligned}$$

Furthermore,

$$S\varphi(0) = \|\varphi\|_\infty^p \int_0^1 G(0, s) a(s, \varphi(s)) ds,$$

which implies that

$$S\varphi(0) \geq a_0 \|\varphi\|_\infty^p \int_0^b G(0, s) ds,$$

where $0 < a_0 = \min_{0 \leq s \leq 1} a(s)$. Consequently

$$S\varphi(0) \geq a_0 b (1 - b/2) \|\varphi\|_\infty^p.$$

Since $1 - p > 0$ it follows that $t^{1-p} \leq a_0 b(1 - b/2)$ if $t = R_1$, for some small $R_1 < R_2$. Hence $t \leq a_0 b(1 - b/2)t^p$ and so

$$\|\varphi\|_\infty \leq a_0 b(1 - b/2)\|\varphi\|_\infty^p \text{ if } \|\varphi\|_\infty = R_1$$

and it follows that $S\varphi(0) \geq \|\varphi\|_\infty$ if $\|\varphi\|_\infty = R_1$ and then

$$\|S\varphi\|_\infty \geq \|\varphi\|_\infty \text{ if } \|\varphi\|_\infty = R_1.$$

In order to use (C_2) of theorem 4.1 we take

$$\Omega_1 = B_{R_1}(0) \subset \Omega_2 = B_{R_2}(0) \subset E$$

and so S has one fixed point in $P \cap (\overline{\Omega_2}/\Omega_1)$.

Let us consider $p > 1$. In this case $t^{p-1} \rightarrow 0$ if $t \rightarrow 0$, and because $S\varphi(t) \leq a_\infty \|\varphi\|_\infty^p$, there is $R_1 > 0$, small enough, such that

$$\|a\|_\infty \|\varphi\|_\infty^{p-1} \leq 1 \text{ if } \|\varphi\|_\infty = R_1$$

and it follows of this that

$$\|S\varphi\|_\infty \leq \|\varphi\|_\infty \text{ if } \|\varphi\|_\infty = R_1.$$

In view of $p > 1$ there is $R_2 > R_1$, R_2 large enough, so that

$$\|\varphi\|_\infty^{p-1} \geq \frac{1}{a_0 b(1 - b/2)} \text{ if } \|\varphi\|_\infty = R_2$$

↓

$$\|\varphi\|_\infty^p a_0 b(1 - b/2) \geq \|\varphi\|_\infty \text{ if } \|\varphi\|_\infty = R_2$$

↓

$$\|S\varphi\|_\infty \geq \|\varphi\|_\infty \text{ if } \|\varphi\|_\infty = R_2.$$

Reasoning as before, at this time using (C_1) , we find a fixed point u of S in $P \cap (\overline{\Omega_2}/\Omega_1)$. □

References

- [1] C.O. Alves and F.J.S.A. Corrêa, *On existence of solutions for a class of problem involving a nonlinear operator*, Communications on Applied Nonlinear Analysis **8** (2001), N. 2, 43-56.
- [2] C.O. Alves and D.G. de Figueiredo, *Nonvariational elliptic systems via Galerkin methods*, Function Spaces, Differential Operators and Nonlinear Analysis – The Hans Triebel Anniversary Volume, Birkhäuser, Basel, 2003, 47-57.
- [3] M. Chipot and J.F. Rodrigues, *On a class of nonlinear elliptic problems*, Mathematical Modelling and Numerical Analysis **26**, No. 3 (1992), 447-468.
- [4] F.J.S.A. Corrêa, J. Ferreira and S.D.B. Menezes, *On a class of problems involving a nonlocal operator*, Applied Mathematics and Computation **147** (2004), 475-489.
- [5] F.J.S.A. Corrêa and S.D.B. Menezes, *Existence of solutions to nonlocal and singular elliptic problems via Galerkin method*, Eletronic Journal of Differential Equations **19** (2004=, 1-10.

- [6] H.W. Chen, *Analysis of blow-up for a nonlinear degenerate parabolic equation*, J. Math. Anal. Appl. **192** (1995), 180-193.
- [7] K. Deimling, *Nonlinear functional analysis*, Springer-Verlag, 1985.
- [8] L.C. Evans, *Partial Differential Equations*, Graduate Studies in Mathematics, Vol. 19, AMS, 2002.
- [9] W.B. Deng, Z.W. Duan and C.H. Xie, *The blow-up rate for a degenerate parabolic equation with a nonlocal source*, J. Math. Anal. Appl. **264**(2) (2001), 577-597.
- [10] W. Deng, Y. Li and C. Xie, *Existence and nonexistence of global solutions of some nonlocal degenerate parabolic equations*, Applied Mathematics Letters **16** (2003), 803-808.
- [11] D. Guo and V. Lakshmikantham, *Nonlinear problems in abstract cones*, Academic Press, Orlando, FL (1988).
- [12] J.L. Lions, *Quelques méthodes de resolution des problemes aux limites non lineaires*, Dunod-Gauthier-Villars, Paris, 1969.
- [13] G. Stampacchia, *Le probleme de Dirichlet pour les equations elliptiques du second ordre a coefficients discontinus*, Ann. Inst. Fourier **15** (1965), 189-258.
- [14] R. Stańczy, *Nonlocal elliptic equations*, Nonlinear Analysis **47** (2001), 3579-3584.

F.J.S.A. Corrêa¹ and S.D.B. Menezes
Departamento de Matemática – CCEN
Universidade Federal do Pará
66.075-110 Belém-Pará
Brazil
e-mail: fjulio@ufpa.br
silvano@ufpa.br

¹Correspondent author.

On a Class of Critical Elliptic Equations of Caffarelli-Kohn-Nirenberg Type

David G. Costa and Olímpio H. Miyagaki

Dedicated to Prof. Djairo G. de Figueiredo on the occasion of his 70th birthday

Abstract. In this work we consider a class of critical elliptic equations of Caffarelli-Kohn-Nirenberg type

$$\begin{cases} -\operatorname{div}(|x|^{-2a}\nabla u) - \mu \frac{u}{|x|^{2(1+a)}} = f(x, u) & \text{in } \Omega \setminus \{0\} \\ u = 0 & \text{on } \partial\Omega \\ u > 0 & \text{in } \Omega \setminus \{0\}, \end{cases} \quad (P_f)$$

where $\Omega \subset \mathbb{R}^N$ ($N \geq 4$) is a smooth domain containing the origin, $-\infty < \mu \leq \bar{\mu} = \frac{(N-2-2a)^2}{4}$, $-\infty < a < \frac{N-2}{2}$ and $f : \Omega \times \mathbb{R} \rightarrow \mathbb{R}$ is a non negative measurable function with critical growth. By using a variant of the concentration compactness principle of P.L. Lions together with standard arguments by Brezis and Nirenberg, we obtain some existence and nonexistence results when Ω is a bounded domain, the whole space \mathbb{R}^N or an infinite cylinder.

Keywords. Caffarelli-Kohn-Nirenberg inequality, critical Sobolev exponent, positive solution.

Introduction

In this work we consider the following class of critical elliptic equations of Caffarelli-Kohn-Nirenberg type

$$\begin{cases} -\operatorname{div}(|x|^{-2a}\nabla u) - \mu \frac{u}{|x|^{2(1+a)}} = f(x, u) & \text{in } \Omega \setminus \{0\} \\ u = 0 & \text{on } \partial\Omega \\ u > 0 & \text{in } \Omega \setminus \{0\}, \end{cases} \quad (P_f)$$

where $\Omega \subset \mathbb{R}^N$ ($N \geq 4$) is a smooth domain containing the origin, $-\infty < \mu \leq \bar{\mu} := \frac{(N-2-2a)^2}{4}$, $-\infty < a < \frac{N-2}{2}$ and $f : \Omega \times \mathbb{R} \rightarrow \mathbb{R}$ is a non negative measurable function with critical growth.

This kind of equation models several phenomena of interest in astrophysics, e.g. Wheeler-De Witt's, Eddington's and Matukuma's equations (see [4, 2]).

First of all, we would like to remark that if u is a smooth function satisfying (P_f) with $\mu = 0$, then, multiplying the equation by $(1 - N/2)u - x \cdot \nabla u$ and integrating by parts, gives the following Pohozaev type inequality (cf. [15]).

$$\begin{aligned} & \int_{\Omega} (|\nabla u|^2(\operatorname{div}(|x|^{-2a}x) + 2(1 - N/2)|x|^{-2a}))dx - \int_{\Omega} 2|x|^{-2a}|\nabla u|^2 dx \\ &= 2 \int_{\Omega} ((1 - N/2)uf(x, u) + F(x, u)N + x \cdot \nabla_x F(x, u))dx \\ & \quad - \int_{\partial\Omega} |x|^{-2a}|\nabla u|^2 x \cdot \nu ds, \end{aligned}$$

where $F(x, s) = \int_0^s f(x, t)dt$ and ν denotes the outward normal to $\partial\Omega$. In the above identity, by taking $f(x, u) = \mu \frac{u}{|x|^{2(1+a)}} + \frac{u^{p-1}}{|x|^{bp}}$, with $p = p(a, b) = \frac{2N}{N-2(1+a-b)}$, $a \leq b < a + 1$, we get

$$\int_{\partial\Omega} |x|^{-2a}|\nabla u|^2 x \cdot \nu ds = \mu(-2(1 + a) + 2 + 2a) \int_{\Omega} |x|^{-2(1+a)}u^2 dx,$$

which is impossible if $u \neq 0$ and Ω is, say, a star-shaped domain. On the other hand, if $f(x, u) = \mu \frac{u}{|x|^{2(1+a)}} + \lambda \frac{u}{|x|^a} + \frac{u^{p-1}}{|x|^{bp}}$ then, from the above Pohozaev identity, we have

$$\int_{\partial\Omega} |x|^{-2a}|\nabla u|^2 x \cdot \nu ds = \lambda(2 + a) \int_{\Omega} |x|^{-a}u^2 dx.$$

Therefore, if Ω is a star-shaped domain and $a > -2$, it follows that the problem

$$\begin{cases} -\operatorname{div}(|x|^{-2a}\nabla u) - \mu \frac{u}{|x|^{2(1+a)}} = \lambda \frac{u}{|x|^a} + \frac{u^{p-1}}{|x|^{bp}} & \text{in } \Omega \setminus \{0\} \\ u = 0 & \text{on } \partial\Omega \\ u > 0 & \text{in } \Omega \setminus \{0\} \end{cases} \quad (P)$$

has no nontrivial solution when $\lambda \leq 0$.

In this paper we are concerned with existence results for the above class of problems when $\lambda > 0$ and Ω is either a bounded domain, the whole space \mathbb{R}^N or an infinite cylinder. We remark that the radial version of problem (P_f) in a ball $B_R(0)$ has been studied in [16, 17].

We start with the pioneering paper by Brezis and Nirenberg [7] where the case $a = b = \mu = 0$ in a bounded domain was treated. In their paper, compactness was recovered by establishing the inequality

$$S_{\lambda}(\Omega) < S_0(\Omega) = S,$$

where

$$S_{\lambda}(\Omega) = \inf_{u \in H^1_o(\Omega) \setminus \{0\}} \frac{\int_{\Omega} (|\nabla u|^2 - \lambda u^2) dx}{(\int_{\Omega} |u|^p dx)^{2/p}}$$

and S is the best constant for the embedding of $H^1_o(\Omega)$ into $L^p(\Omega)$, $p = \frac{2N}{N-2}$ (see [28]). It was proved that the inequality holds when $\lambda \in (0, \lambda_1)$, $N \geq 4$, where λ_1 is the first eigenvalue of $-\Delta$ under Dirichlet boundary condition. In [15] Chou

and Geng extended this result by considering the case $\mu = 0$ and $a \neq 0$ (see also [31]). Recently Ruiz and Willem in [27] studied the case when $a = b = 0$ (see also [4, 21, 22, 24, 29]). Still for this case, Cao and Peng [10] obtained a changing sign solution for (P). We also refer to the paper of Ghossoub and Yan [23] for other related results when $a = \mu = 0$.

In order to state our result, we now define

$$\lambda_1(\mu) = \inf_{u \in E \setminus \{0\}} \left\{ \int_{\Omega} (|x|^{-2a} |\nabla u|^2 - \mu \frac{u^2}{|x|^{2(1+a)}}) dx; |u|_{2,a} = \int_{\Omega} |x|^{-a} u^2 dx = 1 \right\},$$

where $-\infty < \mu < \bar{\mu}$, $a > -2$ and $E = D_a^{1,2}(\Omega)$ denotes the Sobolev space obtained as the completion of $C_0^\infty(\Omega)$ with respect to the norm

$$\|u\|_a = \left(\int_{\Omega} |x|^{-2a} |\nabla u|^2 dx \right)^{1/2}.$$

This norm is equivalent to the norm

$$\|u\| = \left(\int_{\Omega} (|x|^{-2a} |\nabla u|^2 - \mu \frac{u^2}{|x|^{2(1+a)}}) dx \right)^{1/2},$$

for all $\mu \in (-\infty, \bar{\mu})$, where $\bar{\mu} = \left(\frac{N-2-2a}{2}\right)^2$ is the best constant in the Hardy-Sobolev inequality (see [8, 11, 20]). Hereafter $L^r(\Omega, |x|^{-\gamma})$ denotes the weighted $L^r(\Omega)$ space with the norm

$$|u|_{r,\gamma} = \left(\int_{\Omega} |x|^{-\gamma} |u|^r dx \right)^{1/r},$$

and by a weak solution of (P) we mean a $u \in E$ satisfying

$$\int_{\Omega} (|x|^{-2a} \nabla u \nabla v - \mu \frac{uv}{|x|^{2(1+a)}} - \lambda \frac{uv}{|x|^a} - \frac{u^{p-1}v}{|x|^{bp}}) dx = 0 \quad \forall v \in E.$$

Our first result is the following

Theorem 0.1. *Let $\Omega \subset \mathbb{R}^N (N \geq 4)$ be a smooth bounded domain with $0 \in \Omega$, $a \leq b < a + 1$, $p = p(a, b)$ and $-2 < a < \frac{N-2}{2}$. Then problem (P) has at least one weak solution, provided one of the conditions below holds:*

- i) $-\infty < \mu \leq \bar{\mu} - (a + 1)^2$ and $\lambda \in (0, \lambda_1(\mu))$
- ii) $\bar{\mu} - (a + 1)^2 < \mu < \bar{\mu}$ and $\lambda \in (\lambda^*(\mu), \lambda_1(\mu))$ where

$$\lambda^*(\mu) = \min_{u \in E \setminus \{0\}} \frac{\int_{\Omega} |x|^{-2a-2\gamma} |\nabla u|^2 dx}{\int_{\Omega} |x|^{-a-2\gamma} |u|^2 dx}, \quad \gamma = \sqrt{\bar{\mu}} + \sqrt{\bar{\mu} - \mu}.$$

In addition, if $\bar{\mu} - (a + 1)^2 < \mu < \bar{\mu}$, $\Omega = B_R(0)$ and $\lambda \leq \lambda^*(\mu)$, then problem (P) has no solution.

Remark 0.1. *Our weak solution u is a regular solution $u \in L^\infty(\Omega, |x|^{-a}) \cap C^{2,\delta}(\Omega \setminus \{0\})$ for some $\delta > 0$ (see [30]).*

Now, when $\Omega = \mathbb{R}^N$, arguing as in [5] one obtains the following Pohozaev type equality in \mathbb{R}^N :

$$0 = \mu(-2(1 + a) + 2 + 2a) \int_{\mathbb{R}^N} |x|^{-2a} u^2 dx + (2 + a) \int_{\mathbb{R}^N} \lambda |x|^{-a} u^2 dx.$$

So, problem (P) has no nontrivial solution if λ is different from 0. Recently, Felli and Schneider studied the case $\lambda = 0$ in [20]. Actually, they found the following explicit family of solutions for (P):

$$U_\epsilon \equiv U_\epsilon^{a,b,\mu}(x) = \epsilon^{-\frac{N-2-2a}{2}} U_1^{a,b,\mu}(x/\epsilon), \quad \epsilon > 0, \tag{0.1}$$

where

$$\begin{aligned} U_1^{a,b,\mu}(x) &= \left(\frac{N(N-2-2a)\sqrt{(N-2-2a)^2-4\mu}}{N-2(1+a-b)} \right)^{\frac{N-2(1+a-b)}{4(1+a-b)}} \tag{0.2} \\ &\times (|x|^{(1-\frac{\sqrt{(N-2-2a)^2-4\mu}}{N-2-2a})(\frac{N-2-2a}{N-2(a+a-b)})}) \\ &\times (1 + |x|^{\frac{2(1+a-b)\sqrt{(N-2-2a)^2-4\mu}}{N-2(1+a-b)}})^{-\frac{N-2(1+a-b)}{2(1+a-b)}}. \end{aligned}$$

Taking $0 \leq \lambda \in L^{r'}(\mathbb{R}^N)$, $r' = \frac{2^*}{2^*-r}$, $1 < r < 2^*$, $2^* = \frac{2N}{N-2}$, Chen and Li [13] studied problem (P_f) with $f(x, u) = \lambda \frac{u^{r-1}}{|x|^a} + \frac{u^p}{|x|^{bp}}$ and $a = \mu = 0$. See some extensions in [1].

For a class of unbounded domains defined below, Del Pino and Felmer [18] studied a subcritical problem when $a = b = \mu = 0$ and $\lambda > 0$. It was observed that some compactness results are recovered in this special class of the domains. This result was extended by Ramos, Wang and Willem [26] for the problem involving critical Sobolev exponents. In [27] Ruiz and Willem treated the case when $a = b = 0$, whereas problem (P) with $\mu = a = b = 0$ in a cylinder was considered in [25].

In order to state our next result, let us introduce the class of unbounded domains considered in [18] (consisting of cylinders or domains between two cylinders which are asymptotically cylinder-like). For $F \subset \mathbb{R}^{N-\ell}$ ($1 \leq \ell \leq N-1$) and $\varepsilon > 0$, denote $F_\varepsilon = \{y \in \mathbb{R}^{N-\ell} : \text{dist}(y, F) < \varepsilon\}$, $\hat{F} = F \times \mathbb{R}^\ell$, $\mathbb{R}^N = \mathbb{R}^{N-\ell} \times \mathbb{R}^\ell$ and $x = (y, z) \in \mathbb{R}^N = \mathbb{R}^{N-\ell} \times \mathbb{R}^\ell$. Then, we consider the following condition on Ω .

- (H) There exist two non-empty bounded open sets $F \subset G \subset \mathbb{R}^{N-\ell}$ such that F is a Lipschitz domain, $\hat{F} \subset \Omega \subset \hat{G}$ and, for each $\varepsilon > 0$ there is $M > 0$ such that $\Omega_z \subset F_\varepsilon$ for all $|z| \geq M$, where $\Omega_z = \{y \in \mathbb{R}^{N-\ell} : (y, z) \in \Omega\}$, $z \in \mathbb{R}^\ell$.

We now state our next result.

Theorem 0.2. a) Suppose that Ω satisfies (H) with $0 \in \Omega$. Assume that $-\infty < \mu < \bar{\mu}$, $\lambda \in (0, \lambda_1(\mu))$, $p = p(a, 0)$ and $-2 < a \leq b = 0$. Then problem (P) has a solution.

- b) Suppose that $\Omega = \mathbb{R}^N$, $-\infty < \mu < \bar{\mu}$, $a \leq b < a + 1$, $p = p(a, b)$, $0 \leq \lambda \in L^{p'}(\mathbb{R}^N, |x|^{b-a})$ ($1/p + 1/p' = 1$) and $-2 < a < \frac{N-2}{2}$. Then problem (P) has a solution.

1. Preliminaries

Let us start with the Caffarelli-Kohn-Nirenberg type inequality (see [8])

$$\left(\int_{\mathbb{R}^N} |x|^{-bp} |u|^p dx\right)^{2/p} \leq S(a, b)^{-1} \int_{\mathbb{R}^N} |x|^{-2a} |\nabla u|^2 dx, \quad u \in C_o^\infty(\mathbb{R}^N),$$

which implies that the embedding $E \subset L^p(\mathbb{R}^N, |x|^{-bp})$ is continuous. The best constant

$$S(a, b) = \inf_{u \in D_a^{1,2}(\mathbb{R}^N) \setminus \{0\}} \frac{\int_{\mathbb{R}^N} |x|^{-2a} |\nabla u|^2 dx}{\left(\int_{\mathbb{R}^N} |x|^{-bp} |u|^p dx\right)^{2/p}}$$

is such that (see [9, 11, 14])

- i) $S(a, a + 1) = \left(\frac{N-2-2a}{2}\right)^2$,
- ii) $S(a, a)$ is not achieved,
- iii) $S(a, b)$ is always achieved when $a < b < a + 1$.

Recently, Xuan [30] proved the following Rellich-Kondrachov type compactness result:

Theorem 1.1. (Xuan) *Let $\Omega \subset \mathbb{R}^N$ ($N \geq 3$) be a smooth bounded domain with $0 \in \Omega$ and $-\infty < a < \frac{N-2}{2}$. Then the embedding $E \subset L^r(\Omega, |x|^{-\alpha})$ is compact if $1 \leq r < \frac{2N}{N-2}$ and $\alpha < (1 + a)r + N(1 - r/2)$.*

We remark that when Ω is a bounded smooth domain, taking into account Theorem 1.1 together with some arguments used in [30] we can assume that $\lambda_1(\mu) > 0$ and it is attained by a positive function ϕ_1 . Now, multiplying equation (P) by ϕ_1 and integrating by parts, we conclude that (P) has a nontrivial solution when $\lambda \in (0, \lambda_1(\mu))$. Also, when Ω is a unbounded domain, we remark that it follows from (H) that $\lambda_1(\mu) > 0$ (see e.g. [19]).

We will prove our results by applying a variant of the concentration compactness lemma of P.L. Lions [25] proved in Wang and Willem [32] for the present singular situation (see also the recent paper [31], as well as [3, 6, 12] for earlier nonsingular cases). We write $\eta_n \rightharpoonup \eta$ in $M(\Omega)$ if, for all $f \in C_o(\Omega)$, one has $\int_\Omega f d\eta_n \rightarrow \int_\Omega f d\eta$, where $M(\Omega)$ denotes the set of finite measures on Ω . We also define the operator

$$L_{\mu,\lambda}(v) = (-\operatorname{div}(|x|^{-2a} \nabla v) - \mu \frac{v}{|x|^{2(a+1)}} - \lambda \frac{v}{|x|^a}) \equiv L_\mu(v) - \lambda I(v) .$$

Lemma 1.1. *Suppose $-\infty < a < \frac{N-2}{2}$, $a \leq b < a + 1$. Let $u_n \in E = D_a^{1,2}(\Omega)$ be such that $u_n \rightharpoonup u$ in E , $u_n \rightarrow u$ a.e. in Ω . Suppose also that*

$$\left(|x|^{-2a} |\nabla(u_n - u)|^2 - \mu \frac{(u_n - u)^2}{|x|^{2(a+1)}}\right) \rightharpoonup \eta \text{ in } M(\Omega) ,$$

$$|x|^{-bq}|u_n - u|^p \rightharpoonup \nu \text{ in } M(\Omega),$$

and define

$$\eta_\infty = \lim_{R \rightarrow \infty} \limsup_{n \rightarrow \infty} \int_{|x| > R} u_n L_{\mu, \lambda}(u_n) dx$$

$$\nu_\infty = \lim_{R \rightarrow \infty} \limsup_{n \rightarrow \infty} \int_{|x| > R} |x|^{-bq}|u_n|^p dx.$$

Then

$$||\nu||^{2/p} \leq (S_\lambda^\mu(\Omega))^{-1} ||\eta|| \text{ and } \nu_\infty^{2/p} \leq (S_\lambda^\mu(\Omega))^{-1} \eta_\infty$$

and

$$\lim_{n \rightarrow \infty} \int_\Omega u_n L_{\mu, \lambda}(u_n) dx = \int_\Omega u L_{\mu, \lambda}(u) dx + \eta_\infty + ||\eta|| ,$$

$$\lim_{n \rightarrow \infty} \int_\Omega |x|^{-bq}|u_n|^p dx = \int_\Omega |x|^{-bq}|u|^p dx + \nu_\infty + ||\nu|| .$$

2. Proofs

The proofs of Theorem 0.1 and Theorem 0.2 will be accomplished by arguing as in [7] (cf. also [24]). Define

$$S_\lambda^\mu(\Omega) = \inf \left\{ \int_\Omega (|x|^{-2a} |\nabla u|^2 - \mu \frac{u^2}{|x|^{2(1+a)}} - \lambda \frac{u^2}{|x|^a}) dx; u \in D_a^{1,2}(\Omega), |u|_{p, bp} = 1 \right\}.$$

We recall that Felli and Schneider proved in [20] that $S_o^\mu(\mathbb{R}^N)$ is attained by the functions U_ϵ given in (0.1) (see [29] for the case $a = 0$). Therefore, we have to prove the inequality

$$S_\lambda^\mu(\Omega) < S_o^\mu(\Omega) = S_o^\mu(\mathbb{R}^N). \tag{2.1}$$

Proof of Theorem 0.1 — Ω a bounded domain. We first prove (2.1) following the arguments used in [24]. Let U_ϵ be the function given in (0.1), so that

$$S_o^\mu(\mathbb{R}^N) = \frac{\int_{\mathbb{R}^N} U_\epsilon L_\mu(U_\epsilon) dx}{(\int_{\mathbb{R}^N} |x|^{-bp} U_\epsilon^p dx)^{2/p}}.$$

We will show that there exists a function $u \in E = D_a^{1,2}(\Omega)$ such that

$$Q_\lambda(u) = \frac{\int_{\mathbb{R}^N} u L_{\mu, \lambda}(u) dx}{(\int_{\mathbb{R}^N} |x|^{-bp} u^p dx)^{2/p}} < S_o^\mu(\mathbb{R}^N).$$

In view of (0.1), (0.2) we can write $U_\epsilon = C_\epsilon \hat{U}_\epsilon$, where

$$C_\epsilon = \epsilon^{-\sqrt{\bar{\mu}} + \gamma} A, \quad \hat{U}_\epsilon = (\epsilon^c |x|^\beta + |x|^{c+\beta})^{-d},$$

and the exponents β, c and d are such that

$$(\beta + c)d = \gamma .$$

From the definition of U_ϵ it follows that

$$L_\mu(\hat{U}_\epsilon) = C_\epsilon^{p-2} |x|^{-bp} \hat{U}_\epsilon^{p-1}$$

and

$$\hat{U}_\epsilon L_{\mu,\lambda}(\hat{U}_\epsilon) = C_\epsilon^{p-2} |x|^{-bp} \hat{U}_\epsilon^p - \lambda |x|^{-a} \hat{U}_\epsilon^2.$$

Next, notice that

$$\begin{aligned} & - \int_{\Omega} uv \operatorname{div}(|x|^c \nabla(uv)) dx \\ &= - \int_{\Omega} (u^2 v \operatorname{div}(|x|^c \nabla v) + 2|x|^c u \nabla u \cdot v \nabla v + v^2 u \operatorname{div}(|x|^c \nabla u)) dx \\ &= - \int_{\Omega} (u^2 v \operatorname{div}(|x|^c \nabla v) + \frac{1}{2} |x|^c \nabla u^2 \nabla v^2 + v^2 u \operatorname{div}(|x|^c \nabla u)) dx \\ &= - \int_{\Omega} (u^2 v \operatorname{div}(|x|^c \nabla v) - \frac{1}{2} v^2 \operatorname{div}(|x|^c \nabla u^2) + v^2 u \operatorname{div}(|x|^c \nabla u)) dx \\ &= - \int_{\Omega} (u^2 v \operatorname{div}(|x|^c \nabla v)) dx + \int_{\Omega} |x|^c |\nabla u|^2 v^2 dx. \end{aligned}$$

Then, letting in the above identity $c = -2a$, $u = \phi$, where $\phi \in C_o^\infty(\Omega)$ is such that $\phi = 1$ in a neighborhood of $x = 0$, and $v = \hat{U}_\epsilon$, we obtain

$$\begin{aligned} & \int_{\Omega} \phi \hat{U}_\epsilon L_{\mu,\lambda}(\phi \hat{U}_\epsilon) dx \\ &= \int_{\Omega} \phi^2 \hat{U}_\epsilon L_{\mu,\lambda}(\hat{U}_\epsilon) dx + \int_{\Omega} (|x|^{-2a} |\nabla \phi|^2 - \lambda \phi^2 |x|^{-a}) \hat{U}_\epsilon^2 dx \\ &= C_\epsilon^{p-2} \int_{\Omega} |x|^{-bp} \phi^2 \hat{U}_\epsilon^p dx + \int_{\Omega} (|x|^{-2a} |\nabla \phi|^2 - \lambda \phi^2 |x|^{-a}) \hat{U}_\epsilon^2 dx, \end{aligned}$$

hence

$$\begin{aligned} Q_\lambda(\phi \hat{U}_\epsilon) &= \frac{C_\epsilon^{p-2} \int_{\mathbb{R}^N} |x|^{-bp} \phi^2 \hat{U}_\epsilon^p dx + \int_{\mathbb{R}^N} (|x|^{-2a} |\nabla \phi|^2 - \lambda \phi^2 |x|^{-a}) \hat{U}_\epsilon^2 dx}{(\int_{\mathbb{R}^N} \phi^p |x|^{-bp} \hat{U}_\epsilon^p dx)^{2/p}} \\ &= \frac{\int_{\mathbb{R}^N} |x|^{-bp} U_\epsilon^p dx + C_\epsilon^2 \int_{\Omega} (|x|^{-2a} |\nabla \phi|^2 - \lambda \phi^2 |x|^{-a}) \hat{U}_\epsilon^2 dx + \alpha(\phi, \epsilon)}{(\int_{\mathbb{R}^N} |x|^{-bp} U_\epsilon^p dx + \beta(\phi, \epsilon))^{2/p}} \end{aligned} \tag{2.2}$$

where

$$\begin{aligned} \alpha(\phi, \epsilon) &= - \int_{\mathbb{R}^N \setminus \Omega} |x|^{-bp} U_\epsilon^p dx + \int_{\Omega} |x|^{-bp} (\phi^2 - 1) U_\epsilon^p dx = O(\epsilon^{N/2}) \\ \beta(\phi, \epsilon) &= - \int_{\mathbb{R}^N \setminus \Omega} |x|^{-bp} U_\epsilon^p dx + \int_{\Omega} |x|^{-bp} (\phi^p - 1) U_\epsilon^p dx = O(\epsilon^{N/2}). \end{aligned} \tag{2.3}$$

On the other hand, we recall that $(\beta + c)d = \gamma = \sqrt{\mu} + \sqrt{\mu - \mu}$, and notice that

$$U_\epsilon \rightarrow G(0, x) = |x|^{-\gamma}, \text{ as } \epsilon \rightarrow 0,$$

where $G(0, x)$ is the generalized fundamental solution of

$$-\operatorname{div}(|x|^{-2a} \nabla u) - \mu \frac{u}{|x|^{2(a+1)}} = 0.$$

We also notice that $G(0, x) \notin L^2(B_\epsilon(0))$ if and only if $\gamma \geq N/2$, equivalently, $\mu \leq \bar{\mu} - (a + 1)^2$. Therefore, from the choice of ϕ , we get

$$\int_{\Omega} (|x|^{-2a} |\nabla \phi|^2 - \lambda \phi^2 |x|^{-a}) \hat{U}_\epsilon^2 dx < 0 \text{ when } \epsilon \text{ is sufficiently small.} \tag{2.4}$$

Finally, combining (2.2),(2.3) and (2.4), we infer that

$$Q_\lambda(\phi \hat{U}_\epsilon) < S_o^\mu(\mathbb{R}^N) \text{ for } \epsilon \text{ small enough.}$$

We have proved (2.1) under hypothesis i).

Proof of (2.1) under hypothesis ii). Arguing as in [24], we can show that $\lambda^*(\mu) > 0$ and it is attained by a positive function. Now let ψ satisfy

$$\int_{\Omega} (|x|^{-2a} |\nabla \psi|^2 - \mu \frac{|\psi|^2}{|x|^{2(a+1)}}) dx = \lambda_1(\mu) \int_{\Omega} |x|^{-a} |\psi|^2 dx.$$

Then we claim that $\phi = |x|^\gamma \psi$ verifies

$$\frac{\int_{\Omega} (|x|^{-2a-2\gamma} |\nabla \phi|^2 dx)}{\int_{\Omega} (|x|^{-a-2\gamma} |\phi|^2 dx)} \geq \lambda_1(\mu) > \lambda^*(\mu).$$

In fact, notice that $\text{div}(x\psi) = n\psi + \nabla \psi \cdot x$ and $\text{div}(x \frac{\phi \psi^2}{|x|^{2(1+a)}}) = \nabla(\frac{\psi^2}{|x|^{2(1+a)}}) \cdot (x\phi) + \frac{\psi^2}{|x|^{2(1+a)}} \text{div}(x\phi)$, so that

$$\begin{aligned} \frac{|\nabla \phi|^2}{|x|^{2(a+\gamma)}} &= (|\nabla \psi|^2 |x|^{-2a} - \mu \frac{\psi^2}{|x|^{2(1+a)}}) \\ &+ \frac{\psi^2}{|x|^{2(1+a)}} (\gamma^2 - \gamma(N - 2a - 2) + \mu) + \text{div}(\gamma x \frac{\psi^2}{|x|^{2(1+a)}}). \end{aligned}$$

The claim is proved by integrating over Ω and recalling that $\gamma^2 - \gamma(N - 2a - 2) + \mu = 0$.

Next, when $\epsilon \rightarrow 0$ we have

$$\begin{aligned} &\int_{\Omega} (|x|^{-2a} |\nabla \phi|^2 - \lambda |\phi|^2 |x|^{-a}) \hat{U}_\epsilon^2 dx \\ &\rightarrow \int_{\Omega} (|x|^{-2a} |\nabla \phi|^2 - \lambda |\phi|^2 |x|^{-a}) |x|^{-2\gamma} dx. \end{aligned}$$

Moreover, $|x|^{-\gamma} \in L^2(B_\epsilon(0))$ since $\bar{\mu} - (a + 1)^2 < \mu < \bar{\mu}$. Therefore, by taking ϕ a minimizer of $\lambda^*(\mu)$ and recalling that $\lambda > \lambda^*(\mu)$, we obtain

$$\int_{\Omega} (|x|^{-2a} |\nabla \phi|^2 - \lambda |\phi|^2 |x|^{-a}) |x|^{-\gamma} dx < 0,$$

so that (2.4) holds true. By combining (2.4) and (2.2) with (2.3) we obtain (2.1) under hypothesis ii).

Now, let $(u_n) \subset E$ be a minimizing sequence for $S_\lambda^\mu(\Omega)$, that is,

$$\int_{\Omega} u_n L_{\mu, \lambda}(u_n) dx \rightarrow S_\lambda^\mu(\Omega) \text{ and } |u_n|_{p, bp} = 1. \tag{2.5}$$

Since $0 < \lambda < \lambda_1(\mu)$, we infer that $S_\lambda^\mu(\Omega) > 0$ for all $\mu < \bar{\mu}$. Also, we may assume that u_n is bounded in E . Therefore, for some subsequence (still denoted by u_n) and some $u \in E$, we have

$$u_n \rightharpoonup u \text{ weakly in } E, \quad u_n \rightarrow u \text{ a.e. on } \Omega,$$

and, by Theorem 1.1,

$$u_n \rightarrow u \text{ strongly in } L^r(\Omega, |x|^{-\alpha}), \quad \alpha < (1+a)r + N(1-r/2), \quad 1 \leq r < \frac{2N}{N-2}$$

with $|u|_{p,bp} \leq 1$. In order to complete the proof it suffices to show that

$$\int_{\Omega} |x|^{-bp} u^p dx = 1.$$

Now, we note that

$$\|u_n\|^2 = \int_{\Omega} (|x|^{-2a} |\nabla u_n|^2 - \mu \frac{u_n^2}{|x|^{2(1+a)}}) dx \geq S_o^\mu(\mathbb{R}^N).$$

and, from (2.5) we infer that

$$\lambda \int_{\Omega} \frac{u^2}{|x|^a} dx \geq S_o^\mu(\mathbb{R}^N) - S_\lambda^\mu(\Omega) > 0,$$

so that $u \neq 0$.

Let $v_n = u_n - u$. Since $v_n \rightharpoonup 0$ weakly in E , we obtain from (2.5) that

$$\|u\|^2 + \|v_n\|^2 - \lambda |u|_{2,a}^2 = S_\lambda^\mu(\Omega) + o(1). \tag{2.6}$$

Therefore, since $|u_n|_{p,bp}^p = 1$, we conclude by a result of Brezis and Lieb (cf [33]) that

$$1 = |u|_{p,bp}^p + |v_n|_{p,bp}^p + o(1),$$

hence

$$1 \leq |u|_{p,bp}^2 + |v_n|_{p,bp}^2 + o(1).$$

Now, by definition of $S_o^\mu(\mathbb{R}^N)$ we have

$$1 \leq |u|_{p,bp}^2 + S_o^\mu(\mathbb{R}^N)^{-1} \|v_n\|^2 + o(1),$$

so that

$$S_\lambda^\mu(\Omega) \leq S_\lambda^\mu(\Omega) |u|_{p,bp}^2 + S_\lambda^\mu(\Omega) S_o^\mu(\mathbb{R}^N)^{-1} \|v_n\|^2 + o(1).$$

Combining (2.6) with the above inequality gives

$$\|u\|^2 - \lambda |u|_{2,a}^2 \leq S_\lambda^\mu(\Omega) |u|_{p,bp}^2,$$

which shows that $S_\lambda^\mu(\Omega)$ is attained at u .

Proof of Theorem 0.1 iii). It follows by arguing as in [16]. □

Proof of Theorem 0.2 — Ω a cylinder. Let $\Omega = \hat{F}$ be an infinite cylinder and $u_n \in E$ a minimizing sequence for $S_\lambda^\mu(\hat{F})$, that is,

$$\int_{\hat{F}} u_n L_{\mu,\lambda}(u_n) dx \longrightarrow S_\lambda^\mu(\hat{F}) \quad \text{and} \quad |u_n|_p = 1 \quad (\text{with } b = 0).$$

Since $0 < \lambda < \lambda_1(\mu)$, we infer that $S_\lambda^\mu(\hat{F}) > 0$ for all $\mu < \bar{\mu}$. Consider the concentration function

$$Q_n(\lambda) \equiv \sup_{y \in \mathbb{R}^\ell} \int_{F \times B(y,\lambda)} u_n^p dx,$$

where $x = (t, y)$ and $B(a, r)$ denotes the ball of radius r centered at a . Since $\lim_{\lambda \rightarrow 0^+} Q_n(\lambda) = 0$ (for all n) and $\lim_{\lambda \rightarrow +\infty} Q_n(\lambda) = 1$, there exists λ_n such that $Q_n(\lambda_n) = 1/2$. Moreover, since

$$\lim_{|y| \rightarrow \infty} \int_{F \times B(y,\lambda_n)} u_n^p dx = 0,$$

there exists $y_n \in \mathbb{R}^\ell$ such that

$$\int_{F \times B(y_n,\lambda_n)} u_n^p dx = Q_n(\lambda_n) = \frac{1}{2}.$$

After translation and rescaling we may assume that

$$\int_{F \times B(0,1)} u_n^p dx = \frac{1}{2}. \tag{2.7}$$

Also, we may assume that $u_n \rightharpoonup u$ weakly in $D_a^{1,2}(\hat{F})$. To finish the proof we must show that

$$\int_{\hat{F}} u^p dx = 1.$$

From Lemma 1.1 with $b = 0$, we obtain

$$1 = \int_{\hat{F}} u^p dx + \nu_\infty + \|\nu\| \tag{2.8}$$

and

$$S_\lambda^\mu(\hat{F}) = \int_{\hat{F}} u L_{\mu,\lambda}(u) dx + \eta_\infty + \|\eta\|.$$

Therefore,

$$S_\lambda^\mu(\hat{F}) \geq S_\lambda^\mu(\hat{F}) \left(\int_{\hat{F}} u^p dx \right)^{2/p} + S_\lambda^\mu(\hat{F}) \nu_\infty^{2/p} + S_0^\mu(\hat{F}) \|\nu\|^{2/p}. \tag{2.9}$$

On the other hand, we get from (2.1) that

$$S_\lambda^\mu(\hat{F}) < S_0^\mu(\hat{F}) = S_0^\mu(\mathbb{R}^n).$$

Then it follows from (2.8) that

$$\int_{\hat{F}} u^p dx, \quad \|\nu\| \quad \text{and} \quad \nu_\infty \quad \text{are equal to 0 or 1.}$$

But, by (2.7), we have $\nu_\infty \leq 1/2$ and, so, $\nu_\infty = 0$. Assume by contradiction that $u = 0$. Then, from (2.8) we get $\|\nu\| = 1$, and we conclude from (2.9) that

$$S_\lambda^\mu(\hat{F}) \geq S_0^\mu(\hat{F}),$$

which is a contradiction. Therefore,

$$\int_{\hat{F}} u^p dx = 1. \tag*{\square}$$

Proof of Theorem 0.2 — Ω verifying (H). Let $u_n \in E$ be a minimizing sequence for $S_\lambda^\mu(\Omega)$, that is,

$$\int_{\Omega} u_n L_{\mu,\lambda}(u_n) dx \longrightarrow S_\lambda^\mu(\Omega) \quad \text{and} \quad |u_n|_p = 1 \quad (\text{with } b = 0).$$

Since $0 < \lambda < \lambda_1(\mu)$, we infer that $S_\lambda^\mu(\Omega) > 0$ for all $\mu < \bar{\mu}$. Also, we may assume that $u_n \rightharpoonup u$ weakly in $D_a^{1,2}(\Omega)$. Therefore, it suffices to prove that

$$\int_{\Omega} u^p dx = 1.$$

From Lemma 1.1 with $b = 0$ we obtain

$$1 = \int_{\Omega} u^p dx + \nu_\infty + \|\nu\| \tag{2.10}$$

and

$$S_\lambda^\mu(\Omega) = \int_{\Omega} u L_{\mu,\lambda}(u) dx + \eta_\infty + \|\eta\|. \tag{2.11}$$

Since $S_\lambda^\mu(\hat{F})$ is attained (cf. the first part), we choose $\hat{F} \subset \Omega$ such that

$$S_\lambda^\mu(\Omega) < S_\lambda^\mu(\hat{F}).$$

Now, arguing as in [26, Lemma 2.4], there exists $\delta > 0$ (small enough) such that

$$S_\lambda^\mu(\Omega) < S_\lambda^\mu(\hat{F}_\delta). \tag{2.12}$$

Given $r > 1$, let $\psi_r \in C^\infty(\mathbb{R}^N)$ be such that $0 \leq \psi_r \leq 1$, $\psi_r(x) = 1$ for $|x| > r + 1$ and $\psi_r(x) = 0$ for $|x| < r$. Since $u_n \rightharpoonup u$ weakly in E , we have

$$\eta_\infty = \lim_{r \rightarrow \infty} \limsup_{n \rightarrow \infty} \int_{|x| > r} \psi_r u_n L_{\mu,\lambda}(\psi_r u_n) dx,$$

$$\nu_\infty = \lim_{r \rightarrow \infty} \limsup_{n \rightarrow \infty} \int_{|x| > r} |\psi_r u_n|^p dx.$$

Using (H) we can assume $\phi_r u_n \in D_a^{1,2}(\hat{F}_\delta)$ for all r large. Lemma 1.1 gives

$$\eta_\infty \geq S_\lambda^\mu(\hat{F}_\delta) \nu_\infty^{2/p}, \tag{2.13}$$

and from (2.11), (2.12) and (2.13) we obtain

$$\begin{aligned} \int_{\Omega} u L_{\mu,\lambda}(u) dx &\leq S_\lambda^\mu(\Omega) - \eta_\infty - \|\eta\| \\ &\leq S_\lambda^\mu(\Omega) (1 - \|\nu\|^{2/p} - \nu_\infty^{2/p}) \end{aligned} \tag{2.14}$$

Assume by contradiction that either $\|\nu\| \neq 0$ or $\nu_\infty \neq 0$. By convexity we get

$$(1 - \|\nu\|^{2/p} - \nu_\infty^{2/p}) \leq (1 - \|\nu\| - \nu_\infty)^{2/p} = \left(\int_\Omega u^p dx\right)^{2/p}. \quad (2.15)$$

Combining (2.14) and (2.15) we have

$$0 \leq \int_\Omega u L_{\mu,\lambda}(u) dx < S_\lambda^\mu(\Omega) \left(\int_\Omega u^p dx\right)^{2/p},$$

so that $u \neq 0$. Letting $v = u / \left(\int_\Omega u^p dx\right)^{1/p}$ we have

$$\int_\Omega v^p dx = 1$$

which, from the above, yields the contradiction

$$\int_\Omega u L_{\mu,\lambda}(v) dx < S_\lambda^\mu(\Omega).$$

Thus, $\|\nu\| = \nu_\infty = 0$ and

$$\int_\Omega u^p dx = 1. \quad \square$$

Proof of Theorem 0.2 — $\Omega = \mathbb{R}^N$. The proof is accomplished by arguing as in the proof of Theorem 0.2 when Ω is a cylinder. However, by the assumption on λ , the operator $u \mapsto \int_{\mathbb{R}^N} \lambda \frac{u}{|x|^\alpha} dx$ is weakly continuous in our case. Thus $S_\lambda^\mu(\mathbb{R}^N)$ is attained. \square

References

- [1] C. O. Alves, J. V. Goncalves and C. Santos, *Quasilinear singular equations with Hardy-Sobolev exponents*, preprint, 2004.
- [2] M. Badiale and G. Tarantello, *A Sobolev-Hardy inequality with applications to a nonlinear elliptic equation arising in astrophysics*, Arch. Rat. Mech. Anal. **163** (2002), 259–293.
- [3] A. K. Ben-Naoum, C. Troestler and M. Willem, *Extrema problems with critical Sobolev exponents on unbounded domains*, Nonlinear Anal. TMA **26** (1996), 823–833.
- [4] H. Berestycki and M.J. Esteban, *Existence and bifurcation of solutions for an elliptic degenerate problem*, J. Diff. Eqns. **134** (1997), 1–25.
- [5] H. Berestycki and P. L. Lions, *Nonlinear scalar field equations, I (Existence of a ground state)*, Arch. Rat. Mech. Anal. **82** (1983), 313–345.
- [6] G. Bianchi, J. Chabrowski and A. Szulkin, *On symmetric solutions of an elliptic equation with a nonlinearity involving critical Sobolev exponent*, Nonl. Anal. TMA **25** (1995), 41–59.
- [7] H. Brezis and L. Nirenberg, *Positive solutions of nonlinear elliptic equations involving critical Sobolev exponents*, Comm. Pure Appl. Math. **36** (1983), 437–477.
- [8] L. Caffarelli, R. Kohn and L. Nirenberg, *First order interpolation inequalities with weights*, Composito Math. **53** (1984), 259–275.

- [9] P. Caldiroli and R. Musina, *On the existence of extremal functions for a weighted Sobolev embedding with critical exponent*, Calc. Var. PDE **8** (1999), 365–387.
- [10] D.M. Cao and S. Peng, *A note on the sign-changing solutions to elliptic problems with critical Sobolev and Hardy Terms*, J. Diff. Eqns. **193** (2003), 424–434.
- [11] F. Catrina and Z.Q. Wang, *On the Caffarelli-Kohn-Nirenberg inequalities: sharp constants, existence (and nonexistence), and symmetry of extremal functions*, Comm. Pure Appl. Math. **54** (2001), 229–258.
- [12] J. Chabrowski, *Concentration – compactness principle at infinity and semilinear elliptic equations involving critical and subcritical Sobolev exponents*, Calc. Var. PDE **3** (1996), 493–512.
- [13] J. Chen and S. Li, *On multiple solutions of a singular quasilinear equation on unbounded domain*, J. Math. Anal. Appl. **275** (2002), 733–746.
- [14] K.S. Chou and C.W. Chu, *On the best constant for a weighted Sobolev-Hardy inequality*, J. London Math. Soc. **48** (1993), 137–151.
- [15] K.S. Chou and D. Geng, *On the critical dimension of a semilinear degenerate elliptic equation involving critical Sobolev-Hardy exponent*, Nonlinear Anal. TMA **26** (1996), 1965–1984.
- [16] P. Clément, D. G. de Figueiredo and E. Mitidieri, *Quasilinear elliptic equations with critical exponents*, Top. Meth. Nonlinear Anal. **7** (1996), 133–170.
- [17] P. Clément, R. Manásevich and E. Mitidieri, *Some existence and non-existence results for a homogeneous quasilinear problem*, Asymptotic Anal. **17** (1998), 13–29.
- [18] M. Del Pino and P. Felmer, *Least energy solutions for elliptic equations in unbounded domains*, Proc. Royal Soc. Edinburgh **126A** (1996), 195–208
- [19] M. J. Esteban, *Nonlinear elliptic problems in strip-like domains: symmetry of positive vortex rings*, Nonlinear Anal. TMA **7** (1983), 365–379.
- [20] V. Felli and M. Schneider, *Perturbation results of critical elliptic equations of Caffarelli-Kohn-Nirenberg type*, J. Diff. Eqns. **191** (2003), 121–142.
- [21] A. Ferrero and F. Gazzola, *Existence of solutions for singular critical growth semilinear elliptic equations*, J. Diff. Eqns. **177** (2001), 494–522.
- [22] J.P. Garcia Peral and I. Peral Alonso, *Hardy inequalities and some critical elliptic and parabolic problems*, J. Diff. Eqns. **144** (1998), 441–476.
- [23] N. Ghoussoub and C. Yuan, *Multiple solutions for quasi-linear pdes involving the critical Sobolev and Hardy exponents*, Trans. Amer. Math. Soc. **352** (2000), 3703–3743.
- [24] E. Jannelli, *The role played by space dimension in elliptic critical problems*, J. Diff. Eqns. **156** (1999), 407–426.
- [25] P. L. Lions, *The concentration compactness principle in the calculus of variations. The limite case, Part 2*, Rev. Mat. Iberoamericana **1** (1985), 45–121.
- [26] M. Ramos, Z.Q. Wang and M. Willem, *Positive solutions for elliptic equations with critical growth in unbounded domains*, in “Calculus of Variations and Differential Equations” (ed A. Ioffe, S. Reich and I. Shafrir), Chapman and Hall/CRC Press, Boca Raton(1999), pp. 192–199.
- [27] D. Ruiz and M. Willem, *Elliptic problems with critical exponents and Hardy potential*, J. Diff. Eqns. **190** (2003), 524–538.

- [28] G. Talenti, *Best constants in Sobolev inequality*, Ann. Mat. Pure Appl. **110** (1976), 353–372.
- [29] S. Terracini, *On positive entire solutions to a class of equations with a singular coefficient and critical exponent*, Adv. Diff. Eqns. **1**(2), 1996, 241–264.
- [30] B. Xuan, *The eigenvalue problem for a singular quasilinear elliptic equation*, Electronic J. Diff. Eqns. **16** (2004), 1–11.
- [31] B. Xuan, *The solvability of Brezis-Nirenberg type problems of singular quasilinear elliptic equation*, preprint, 2004.
- [32] Z.Q. Wang and M. Willem, *Singular minimization problems*, J. Diff. Eqns. **161** (2000), 307–320.
- [33] M. Willem, “Minimax Theorems”, Birkhäuser, Berlin, 1996.

David G. Costa
Department of Math. Sciences
University of Nevada – Las Vegas
Las Vegas, NV 89154-4020
USA
e-mail: costa@unlv.nevada.edu

Olímpio H. Miyagaki¹
Departamento de Matemática
Universidade Federal de Viçosa
36570-000 Viçosa, MG
Brazil
e-mail: olimpio@ufv.br

¹Supported in part by CNPq/Brazil and the Millennium Institute-MCT/Brazil

Existence and Number of Solutions for a Class of Semilinear Schrödinger Equations

Yanheng Ding and Andrzej Szulkin

Dedicated to Djairo G. de Figueiredo on the occasion of his 70th birthday

Abstract. Using an argument of concentration-compactness type we study the problem $-\Delta u + \lambda V(x)u = |u|^{p-2}u$, $x \in \mathbb{R}^N$, where $2 < p < 2^*$ and the set $\{x \in \mathbb{R}^N : V(x) < b\}$ is nonempty and has finite measure for some $b > 0$. In particular, we show that if $V^{-1}(0)$ has nonempty interior, then the number of solutions increases with λ . We also study concentration of solutions on the set $V^{-1}(0)$ as $\lambda \rightarrow \infty$.

1. Introduction

The purpose of this paper is to present simple proofs of some results concerning the existence and the number of decaying solutions for the Schrödinger equation

$$-\Delta u + V(x)u = |u|^{p-2}u, \quad x \in \mathbb{R}^N, \quad (1.1)$$

and for the related equations

$$-\Delta u + \lambda V(x)u = |u|^{p-2}u, \quad x \in \mathbb{R}^N, \quad (1.2)$$

and

$$-\varepsilon^2 \Delta u + V(x)u = |u|^{p-2}u, \quad x \in \mathbb{R}^N, \quad (1.3)$$

respectively as $\lambda \rightarrow \infty$ and $\varepsilon \rightarrow 0$. In a concluding section we shall also consider concentration of solutions as $\lambda \rightarrow \infty$ or $\varepsilon \rightarrow 0$. We shall assume throughout that V and p satisfy the following assumptions:

(V₁) $V \in C(\mathbb{R}^N)$ and V is bounded below.

(V₂) There exists $b > 0$ such that the set $\{x \in \mathbb{R}^N : V(x) < b\}$ is nonempty and has finite measure.

(P) $p \in (2, 2^*)$, where $2^* := 2N/(N - 2)$ if $N \geq 3$ and $2^* := +\infty$ if $N = 1$ or 2 .

Assumption (V_1) is only for simplicity. In Sections 2 and 3 it can be replaced by (V'_1) $V \in L^1_{loc}(\mathbb{R}^N)$ and $V^- := \max\{-V, 0\} \in L^q(\mathbb{R}^N)$, where $q = N/2$ if $N \geq 3$, $q > 1$ if $N = 2$ and $q = 1$ if $N = 1$

while in Section 4 we also need $V \in L^q_{loc}(\mathbb{R}^N)$. Such an extension requires nothing more than a simple modification of our arguments.

Note that if $\varepsilon^2 = \lambda^{-1}$, then u is a solution of (1.2) if and only if $v = \lambda^{-1/(p-2)}u$ is a solution of (1.3), hence as far as the existence and the number of solutions are concerned, these two problems are equivalent.

Problem (1.3) with $V \geq 0$ and a more general right-hand side has been studied extensively by several authors, see e.g. [5, 10, 11] and the references therein. For a problem similar to (1.2), again with $V \geq 0$ and a more general right-hand side, see [2]. In a recent work [6] it has been shown that for a certain class of functions V which may change sign, (1.1) has infinitely many solutions, see Remark 3.6 below. The results of the present paper extend and complement those mentioned above. In particular, our assumptions on V are rather weak, but perhaps more important, our proofs seem to be new and simpler. On the other hand, contrary to [5, 10, 11], we do not study single- or multispike solutions of (1.3) as $\varepsilon \rightarrow 0$. In a forthcoming paper we shall consider (1.2) for a much more general class of nonlinearities. However, this will be done at the expense of the simplicity of arguments.

Below $\|u\|_p$ will denote the usual $L^p(\mathbb{R}^N)$ -norm and $V^\pm(x) := \max\{\pm V(x), 0\}$. B_ρ and S_ρ will respectively denote the open ball and the sphere of radius ρ and center at the origin.

It is well known that the functional

$$\Phi(u) := \frac{1}{2} \int_{\mathbb{R}^N} (|\nabla u|^2 + V(x)u^2) dx - \frac{1}{p} \int_{\mathbb{R}^N} |u|^p dx$$

is of class C^1 in the Sobolev space

$$E = \{u \in H^1(\mathbb{R}^N) : \|u\|^2 := \int_{\mathbb{R}^N} (|\nabla u|^2 + V^+(x)u^2) dx < \infty\} \tag{1.4}$$

and critical points of Φ correspond to solutions u of (1.1). Moreover, $u(x) \rightarrow 0$ as $|x| \rightarrow \infty$. It is easy to see that if

$$M := \inf_{u \in E \setminus \{0\}} \frac{\int_{\mathbb{R}^N} (|\nabla u|^2 + V(x)u^2) dx}{\|u\|_p^2} \tag{1.5}$$

is attained at some \bar{u} and M is positive, then $u = M^{1/(p-2)}\bar{u}/\|\bar{u}\|_p$ is a solution of (1.1) and $u(x) \rightarrow 0$ as $|x| \rightarrow \infty$. Such u is called a ground state. We note for further reference that (V_1) , (V_2) and the Poincaré inequality imply E is continuously embedded in $H^1(\mathbb{R}^N)$. For basic critical point theory in a setting suitable for our purposes the reader is referred e.g. to [7, 14]. That $u(x) \rightarrow 0$ as $|x| \rightarrow \infty$ can be seen as follows. If $N = 1$ and $u \in H^1(\mathbb{R})$, then $u(x) \rightarrow 0$ as $|x| \rightarrow \infty$. Suppose $N \geq 2$, let u be a solution of (1.1) and set $W(x) = V(x) - |u(x)|^{p-2}$. Since V is continuous, bounded below and $|u|^{p-2} \in L^r(\mathbb{R}^N)$ for some $r > N/2$, it is easy to

verify that $W^+ \in K_N^{loc}$ and $W^- \in K_N$, where K_N and K_N^{loc} are the Kato classes as defined in Section A2 of [13]. Since $-\Delta u + W(x)u = 0$, $u(x) \rightarrow 0$ according to Theorem C.3.1 in [13]. An alternative proof, for a much more general class of Schrödinger equations including those with V satisfying (V_1') instead of (V_1) , may be found in [8].

2. Compactness

In this section we study the compactness of minimizing sequences and of Palais-Smale sequences. We adapt well known arguments (see e.g. [7, 14]) to our situation.

Let

$$V_b(x) := \max\{V(x), b\},$$

and

$$M_b := \inf_{u \in E \setminus \{0\}} \frac{\int_{\mathbb{R}^N} (|\nabla u|^2 + V_b(x)u^2) dx}{\|u\|_p^2}. \tag{2.1}$$

Denote the spectrum of $-\Delta + V$ in $L^2(\mathbb{R}^N)$ by $\sigma(-\Delta + V)$ and recall the definition (1.5) of M .

Theorem 2.1. *Suppose (V_1) , (V_2) , (P) are satisfied and $\sigma(-\Delta + V) \subset (0, \infty)$. If $M < M_b$, then each minimizing sequence for M has a convergent subsequence. So in particular, M is attained at some $u \in E \setminus \{0\}$.*

Proof. Let (u_m) be a minimizing sequence. We may assume $\|u_m\|_p = 1$. Since $V < 0$ on a set of finite measure, (u_m) is bounded in the norm of E given by (1.4). Passing to a subsequence we may assume $u_m \rightharpoonup u$ in E and by the continuity of the embedding $E \hookrightarrow H^1(\mathbb{R}^N)$, $u_m \rightarrow u$ in $L^2_{loc}(\mathbb{R}^N)$, $L^p_{loc}(\mathbb{R}^N)$ and a.e. in \mathbb{R}^N . Let $u_m = v_m + u$. Then

$$\begin{aligned} & \int_{\mathbb{R}^N} (|\nabla u_m|^2 + V(x)u_m^2) dx \\ &= \int_{\mathbb{R}^N} (|\nabla v_m|^2 + V(x)v_m^2) dx + \int_{\mathbb{R}^N} (|\nabla u|^2 + V(x)u^2) dx + o(1) \end{aligned} \tag{2.2}$$

and by the Brézis-Lieb lemma [4], [14, Lemma 1.32],

$$\int_{\mathbb{R}^N} |u_m|^p dx = \int_{\mathbb{R}^N} |v_m|^p dx + \int_{\mathbb{R}^N} |u|^p dx + o(1). \tag{2.3}$$

Moreover, by (V_2) and since $v_m \rightarrow 0$,

$$\int_{\mathbb{R}^N} (V(x) - V_b(x))v_m^2 dx \rightarrow 0. \tag{2.4}$$

Using (2.2)–(2.4) and the definitions of M, M_b we obtain

$$\begin{aligned} & \int_{\mathbb{R}^N} (|\nabla u|^2 + V(x)u^2) dx + \int_{\mathbb{R}^N} (|\nabla v_m|^2 + V(x)v_m^2) dx + o(1) = M \\ & = M\|u_m\|_p^2 = M(\|u\|_p^p + \|v_m\|_p^p)^{2/p} + o(1) \leq M(\|u\|_p^2 + \|v_m\|_p^2) + o(1) \\ & \leq \int_{\mathbb{R}^N} (|\nabla u|^2 + V(x)u^2) dx + MM_b^{-1} \int_{\mathbb{R}^N} (|\nabla v_m|^2 + V_b(x)v_m^2) dx + o(1) \\ & \leq \int_{\mathbb{R}^N} (|\nabla u|^2 + V(x)u^2) dx + MM_b^{-1} \int_{\mathbb{R}^N} (|\nabla v_m|^2 + V(x)v_m^2) dx + o(1). \end{aligned}$$

Since $MM_b^{-1} < 1$ and $\int_{\mathbb{R}^N} V^-(x)v_m^2 dx \rightarrow 0$, it follows that $v_m \rightarrow 0$ and therefore $u_m \rightarrow u$. It is clear that $u \neq 0$. □

Remark 2.2. If $M = M_b$, then all inequalities in the last formula above become equalities after passing to the limit. Therefore either $u = 0$ or $u_m \rightarrow u$ in $L^p(\mathbb{R}^N)$. In the latter case M is attained.

From the above theorem it follows that if $\sigma(-\Delta + V) \subset (0, \infty)$ and $M < M_b$, then there exists a ground state solution of (1.1).

We shall also need to work with the functional Φ . Recall that (u_m) is called a Palais-Smale sequence at the level c (a $(PS)_c$ -sequence) if $\Phi'(u_m) \rightarrow 0$ and $\Phi(u_m) \rightarrow c$. If each $(PS)_c$ -sequence has a convergent subsequence, then Φ is said to satisfy the $(PS)_c$ -condition.

Theorem 2.3. *If $(V_1), (V_2)$ and (P) hold, then Φ satisfies $(PS)_c$ for all*

$$c < \left(\frac{1}{2} - \frac{1}{p}\right) M_b^{p/(p-2)}.$$

Proof. Let (u_m) be a $(PS)_c$ -sequence with c satisfying the inequality above. First we show that (u_m) is bounded. We have

$$d_1 + d_2\|u_m\| \geq \Phi(u_m) - \frac{1}{2}\langle \Phi'(u_m), u_m \rangle = \left(\frac{1}{2} - \frac{1}{p}\right) \|u_m\|_p^p \tag{2.5}$$

and

$$\begin{aligned} d_1 + d_2\|u_m\| & \geq \Phi(u_m) - \frac{1}{p}\langle \Phi'(u_m), u_m \rangle \\ & = \left(\frac{1}{2} - \frac{1}{p}\right) \|u_m\|^2 - \left(\frac{1}{2} - \frac{1}{p}\right) \int_{\mathbb{R}^N} V^-(x)u_m^2 dx \end{aligned} \tag{2.6}$$

for some constants $d_1, d_2 > 0$. Suppose $\|u_m\| \rightarrow \infty$ and let $w_m := u_m/\|u_m\|$. Dividing (2.5) by $\|u_m\|^p$ we see that $w_m \rightarrow 0$ in $L^p(\mathbb{R}^N)$ and therefore $w_m \rightarrow 0$ in E after passing to a subsequence. Hence $\int_{\mathbb{R}^N} V^-(x)w_m^2 dx \rightarrow 0$ (recall V^- is bounded; in fact it suffices that $V^- \in L^q(\mathbb{R}^N)$, where q is as in (V'_1)). So dividing (2.6) by $\|u_m\|^2$, it follows that $w_m \rightarrow 0$ in E , a contradiction. Thus (u_m) is bounded.

As in the preceding proof, we may assume $u_m \rightharpoonup u$ in E and $u_m \rightarrow u$ in $L^2_{loc}(\mathbb{R}^N)$, $L^p_{loc}(\mathbb{R}^N)$ and a.e. in \mathbb{R}^N . Set $u_m = v_m + u$. Since $\Phi'(u) = 0$ and $\Phi(u) = \Phi(u) - \frac{1}{2}\langle \Phi'(u), u \rangle = (\frac{1}{2} - \frac{1}{p})\|u\|_p^p \geq 0$, it follows from (2.2), (2.3) that

$$0 = \langle \Phi'(u_m), u_m \rangle + o(1) = \langle \Phi'(v_m), v_m \rangle + \langle \Phi'(u), u \rangle + o(1) = \langle \Phi'(v_m), v_m \rangle + o(1) \tag{2.7}$$

and

$$c = \Phi(u_m) + o(1) = \Phi(v_m) + \Phi(u) + o(1) \geq \Phi(v_m) + o(1). \tag{2.8}$$

By (2.7),

$$\lim_{m \rightarrow \infty} \int_{\mathbb{R}^N} (|\nabla v_m|^2 + V(x)v_m^2) dx = \lim_{m \rightarrow \infty} \int_{\mathbb{R}^N} |v_m|^p dx =: \gamma, \tag{2.9}$$

possibly after passing to a subsequence, and therefore it follows from (2.8) that

$$c \geq \left(\frac{1}{2} - \frac{1}{p}\right) \gamma. \tag{2.10}$$

By (2.4),

$$\lim_{m \rightarrow \infty} \int_{\mathbb{R}^N} (|\nabla v_m|^2 + V_b(x)v_m^2) dx = \lim_{m \rightarrow \infty} \int_{\mathbb{R}^N} (|\nabla v_m|^2 + V(x)v_m^2) dx = \gamma.$$

On the other hand,

$$\|v_m\|_p^2 \leq M_b^{-1} \int_{\mathbb{R}^N} (|\nabla v_m|^2 + V_b(x)v_m^2) dx$$

by the definition (2.1) of M_b ; therefore $\gamma^{2/p} \leq M_b^{-1}\gamma$. Combining this with (2.10) we see that either $\gamma = 0$ or

$$c \geq \left(\frac{1}{2} - \frac{1}{p}\right) M_b^{p/(p-2)},$$

hence γ must be 0 by the assumption on c . So according to (2.9),

$$\lim_{m \rightarrow \infty} \int_{\mathbb{R}^N} (|\nabla v_m|^2 + V^+(x)v_m^2) dx = \lim_{m \rightarrow \infty} \int_{\mathbb{R}^N} (|\nabla v_m|^2 + V(x)v_m^2) dx = 0.$$

Therefore $v_m \rightarrow 0$ and $u_m \rightarrow u$ in E . □

3. Existence of solutions

Theorem 3.1. *Suppose (V_1) and (P) are satisfied, $\sigma(-\Delta+V) \subset (0, \infty)$, $\sup_{x \in \mathbb{R}^N} V(x) = b > 0$ and the measure of the set $\{x \in \mathbb{R}^N : V(x) < b - \varepsilon\}$ is finite for all $\varepsilon > 0$. Then the infimum in (1.5) is attained at some $u \geq 0$. If $V \geq 0$, then $u > 0$ in \mathbb{R}^N .*

Proof. Since V^+ is bounded, $E = H^1(\mathbb{R}^N)$ here. Let u_b be the radially symmetric positive solution of the equation

$$-\Delta u + bu = |u|^{p-2}u, \quad x \in \mathbb{R}^N.$$

It is well known that such u_b exists, is unique and minimizes

$$N_b := \inf_{u \in E \setminus \{0\}} \frac{\int_{\mathbb{R}^N} (|\nabla u|^2 + bu^2) dx}{\|u\|_p^2} \tag{3.1}$$

(see e.g. [7, Section 8.4] or [14, Section 1.7]). So if $V \equiv b$, we are done. Otherwise we may assume without loss of generality that $V(0) < b$. Then

$$\begin{aligned} M &= \inf_{u \in E \setminus \{0\}} \frac{\int_{\mathbb{R}^N} (|\nabla u|^2 + V(x)u^2) dx}{\|u\|_p^2} \leq \frac{\int_{\mathbb{R}^N} (|\nabla u_b|^2 + V(x)u_b^2) dx}{\|u_b\|_p^2} \\ &< \frac{\int_{\mathbb{R}^N} (|\nabla u_b|^2 + bu_b^2) dx}{\|u_b\|_p^2} = N_b = M_b, \end{aligned}$$

where the last equality follows from the fact that $V_b = b$. In order to apply Theorem 2.1 we need to show that $M < M_{b-\varepsilon}$ for some $\varepsilon > 0$ ($M < M_b$ does not suffice because the set $\{x \in \mathbb{R}^N : V(x) < b\}$ may have infinite measure). A simple computation shows that if $\lambda > 0$, then $N_{\lambda b}$ is attained at $u_{\lambda b}(x) = \lambda^{1/(p-2)}u_b(\sqrt{\lambda}x)$ and

$$N_{\lambda b} = \lambda^r N_b, \text{ where } r = 1 - \frac{N}{2} + \frac{N}{p} > 0. \tag{3.2}$$

Choosing $\lambda = (b - \varepsilon)/b$ we see that $N_{b-\varepsilon} < N_b$ and $N_{b-\varepsilon} \rightarrow N_b$ as $\varepsilon \rightarrow 0$. So for ε small enough we have

$$\begin{aligned} M < N_{b-\varepsilon} &= \inf_{u \in E \setminus \{0\}} \frac{\int_{\mathbb{R}^N} (|\nabla u|^2 + (b - \varepsilon)u^2) dx}{\|u\|_p^2} \\ &\leq \inf_{u \in E \setminus \{0\}} \frac{\int_{\mathbb{R}^N} (|\nabla u|^2 + V_{b-\varepsilon}(x)u^2) dx}{\|u\|_p^2} = M_{b-\varepsilon}. \end{aligned}$$

Hence M is attained at some u . Since the expression on the right-hand side of (1.5) does not change if u is replaced by $|u|$, we may assume $u \geq 0$. By the maximum principle, if $V \geq 0$, then $u > 0$ in \mathbb{R}^N . □

Theorem 3.2. *Suppose $V \geq 0$ and (V_1) , (V_2) , (P) are satisfied. Then there exists $\Lambda > 0$ such that for each $\lambda \geq \Lambda$ the infimum in (1.5) (with $V(x)$ replaced by $\lambda V(x)$) is attained at some $u_\lambda > 0$.*

Proof. Here $V = V^+$. Let b be as in (V_2) and

$$\begin{aligned} M^\lambda &:= \inf_{u \in E \setminus \{0\}} \frac{\int_{\mathbb{R}^N} (|\nabla u|^2 + \lambda V(x)u^2) dx}{\|u\|_p^2}, \\ M_b^\lambda &:= \inf_{u \in E \setminus \{0\}} \frac{\int_{\mathbb{R}^N} (|\nabla u|^2 + \lambda V_b(x)u^2) dx}{\|u\|_p^2}. \end{aligned} \tag{3.3}$$

It suffices to show that $M^\lambda < M_b^\lambda$ for all λ large enough. We may assume $V(0) < b$ and choose $\varepsilon, \delta > 0$ so that $V(x) < b - \varepsilon$ whenever $|x| < 2\delta$. Let $\varphi \in C_0^\infty(\mathbb{R}^N, [0, 1])$ be a function such that $\varphi(x) = 1$ for $|x| \leq \delta$ and $\varphi(x) = 0$ for $|x| \geq 2\delta$. Set

$w_{\lambda b}(x) := \varphi(x)u_{\lambda b}(x) \equiv \lambda^{1/(p-2)}u_b(\sqrt{\lambda}x)\varphi(x)$, where u_b is as in the proof of Theorem 3.1. Then for all sufficiently large λ and some $c_0 > 0$,

$$\begin{aligned} M^\lambda &\leq \frac{\int_{\mathbb{R}^N} (|\nabla w_{\lambda b}|^2 + \lambda V(x)w_{\lambda b}^2) dx}{\|w_{\lambda b}\|_p^2} \leq \frac{\int_{\mathbb{R}^N} (|\nabla w_{\lambda b}|^2 + \lambda(b - \varepsilon)w_{\lambda b}^2) dx}{\|w_{\lambda b}\|_p^2} \\ &= \lambda^r \left(\frac{\int_{\mathbb{R}^N} (|\nabla u_b|^2 + bu_b^2) dx - \varepsilon \int_{\mathbb{R}^N} u_b^2 dx}{\|u_b\|_p^2} + o(1) \right) \leq \lambda^r (N_b - c_0\varepsilon) \end{aligned}$$

(N_b is defined in (3.1) and r in (3.2)). Using (3.2) and (3.3) we also see that

$$M_b^\lambda \geq \inf_{u \in E \setminus \{0\}} \frac{\int_{\mathbb{R}^N} (|\nabla u|^2 + \lambda bu^2) dx}{\|u\|_p^2} = N_{\lambda b} = \lambda^r N_b, \tag{3.4}$$

hence $M^\lambda < M_b^\lambda$ (the infimum above is equal to $N_{\lambda b}$ also when E is a proper subspace of $H^1(\mathbb{R}^N)$ because $C_0^\infty(\mathbb{R}^N)$, and hence also E , is dense in $H^1(\mathbb{R}^N)$). By the argument at the end of the proof of Theorem 3.1, the infimum is attained at some $u_\lambda > 0$. □

Remark 3.3. If (V_1) is replaced by (V'_1) , then we need to assume that the set $\{x \in \mathbb{R}^N : V(x) < b - \varepsilon\}$ appearing in Theorem 3.1 has nonempty interior for each $\varepsilon > 0$. Likewise, in Theorem 3.2 the set $\{x \in \mathbb{R}^N : V(x) < b\}$ should have nonempty interior.

Next we shall consider the existence of multiple solutions under the hypothesis that $V^{-1}(0)$ has nonempty interior.

Theorem 3.4. *Suppose $V \geq 0$, $V^{-1}(0)$ has nonempty interior and (V_1) , (V_2) , (P) are satisfied. For each $k \geq 1$ there exists $\Lambda_k > 0$ such that if $\lambda \geq \Lambda_k$, then (1.2) has at least k pairs of nontrivial solutions in E .*

Proof. For a fixed k we can find $\varphi_1, \dots, \varphi_k \in C_0^\infty(\mathbb{R}^N)$ such that $\text{supp } \varphi_j$, $1 \leq j \leq k$, is contained in the interior of $V^{-1}(0)$ and $\text{supp } \varphi_i \cap \text{supp } \varphi_j = \emptyset$ whenever $i \neq j$. Let

$$F_k := \text{span}\{\varphi_1, \dots, \varphi_k\}.$$

Since $V \geq 0$, $\Phi(u) = \frac{1}{2}\|u\|^2 - \frac{1}{p}\|u\|_p^p$ and therefore there exist $\alpha, \rho > 0$ such that $\Phi|_{S_\rho} \geq \alpha$. Denote the set of all symmetric (in the sense that $-A = A$) and closed subsets of E by Σ , for each $A \in \Sigma$ let $\gamma(A)$ be the Krasnoselski genus and

$$i(A) := \min_{h \in \Gamma} \gamma(h(A) \cap S_\rho),$$

where Γ is the set of all odd homeomorphisms $h \in C(E, E)$. Then i is a version of Benci's pseudoindex [1, 3]. Let

$$\Phi_\lambda(u) := \frac{1}{2} \int_{\mathbb{R}^N} (|\nabla u|^2 + \lambda V(x)u^2) dx - \frac{1}{p} \int_{\mathbb{R}^N} |u|^p dx, \quad \lambda \geq 1$$

and

$$c_j := \inf_{i(A) \geq j} \sup_{u \in A} \Phi_\lambda(u), \quad 1 \leq j \leq k.$$

Since $\Phi_\lambda(u) \geq \Phi(u) \geq \alpha$ for all $u \in S_\rho$ and since $i(F_k) = \dim F_k = k$ (see [1, 3]),

$$\alpha \leq c_1 \leq \dots \leq c_k \leq \sup_{u \in F_k} \Phi_\lambda(u) =: C.$$

It is clear that C depends on k but not on λ . As in (3.4), we have

$$M_b^\lambda \geq N_{\lambda b} = \lambda^r N_b,$$

where $r > 0$, and therefore $M_b^\lambda \rightarrow \infty$. Hence $C < (\frac{1}{2} - \frac{1}{p})(M_b^\lambda)^{p/(p-2)}$ whenever λ is large enough and it follows from Theorem 2.3 that for such λ the Palais-Smale condition is satisfied at all levels $c \leq C$. By the usual critical point theory, all c_j are critical levels and Φ_λ has at least k pairs of nontrivial critical points. \square

Next we extend the above result to the case of $V^- \not\equiv 0$. As in [9], we consider the eigenvalue problem

$$-\Delta u + \lambda V^+(x)u = \mu \lambda V^-(x)u, \quad u \in E \tag{3.5}$$

(here $\lambda \geq 1$ is fixed). An equivalent norm $\|u\|_\lambda$ in E is given by the inner product

$$\langle u, v \rangle_\lambda := \int_{\mathbb{R}^N} (\nabla u \cdot \nabla v + \lambda V^+(x)uv) dx.$$

Since $V^- > 0$ on a set of finite measure, the linear operator $u \mapsto \int_{\mathbb{R}^N} \lambda V^-(x)u \cdot dx$ is compact. It follows that there are finitely many eigenvalues $\mu \leq 1$ and the quadratic form

$$u \mapsto \int_{\mathbb{R}^N} (|\nabla u|^2 + \lambda V(x)u^2) dx$$

is negative semidefinite on the space E^- spanned by the corresponding eigenfunctions. It is easy to see that $\dim E^- \rightarrow \infty$ as $\lambda \rightarrow \infty$.

Theorem 3.5. *Suppose $V^- \not\equiv 0$, $V^{-1}(0)$ has nonempty interior and (V_1) , (V_2) , (P) are satisfied. For each $k \geq 1$ there exists $\Lambda_k > 0$ such that if $\lambda \geq \Lambda_k$, then (1.2) has at least k pairs of nontrivial solutions in E .*

Proof. We need to modify the argument of Theorem 3.4. Let φ_j and F_k be as before. If e is an eigenfunction of (3.5) and μ a corresponding eigenvalue, then

$$\langle e, \varphi_j \rangle_\lambda = \mu \lambda \int_{\mathbb{R}^N} V^-(x)e\varphi_j dx = 0 \tag{3.6}$$

because $\text{supp } \varphi_j \subset V^{-1}(0)$. Hence $E_k := E^- + F_k = E^- \oplus F_k$. Let $l = \dim E^-$ and

$$c_j := \inf_{i(A) \geq l+j} \sup_{u \in A} \Phi_\lambda(u), \quad 1 \leq j \leq k.$$

Write $u = e + f$, $e \in E^-$, $f \in F_k$. By (3.6) and since there exists a continuous projection $L^p(\mathbb{R}^N) \rightarrow F_k$,

$$\Phi_\lambda(u) \leq \frac{1}{2} \int_{\mathbb{R}^N} |\nabla f|^2 dx - \frac{\tilde{C}}{p} \int_{\mathbb{R}^N} |f|^p dx$$

for some $\tilde{C} \leq 1$. Thus

$$c_k \leq \sup_{u \in E_k} \Phi_\lambda(u) = C,$$

where C is independent of λ . If $i(A) \geq l + 1$, then $\gamma(h(A) \cap S_\rho) \geq l + 1$ for each $h \in \Gamma$ and therefore $h(A) \cap S_\rho$ intersects any subspace of codimension $\leq l$. The space E has an orthogonal decomposition $E = E^+ \oplus E^- \oplus F$ (with respect to the inner product $\langle \cdot, \cdot \rangle_\lambda$), where E^+ corresponds to the eigenvalues $\mu > 1$ of (3.5) and F is the subspace of functions $u \in E$ whose support is contained in $V^{-1}([0, \infty))$. It is clear that the quadratic part of Φ_λ is positive definite on E^+ , and it is also positive definite on F because $V^{-1}(0)$ has finite measure. Hence there exist $\alpha, \rho > 0$ (possibly depending on λ) such that $\Phi_\lambda|_{S_\rho \cap (E^+ \oplus F)} \geq \alpha$. Since $\text{codim}(E^+ \oplus F) = l$, it follows that $h(A) \cap S_\rho \cap (E^+ \oplus F) \neq \emptyset$ and $c_1 \geq \alpha$. Now it remains to repeat the argument at the end of the preceding proof. \square

Remark 3.6. (i) If $V(x) \rightarrow \infty$ as $|x| \rightarrow \infty$, then it is well known that the embedding $E \hookrightarrow L^q(\mathbb{R}^N)$, $2 \leq q < 2^*$ is compact, see e.g. [2]. Therefore the Palais-Smale condition holds at all levels and (1.1) has infinitely many solutions.

(ii) It has been shown in [6] that if $V \in C^1(\mathbb{R}^N)$ and satisfies certain growth conditions at infinity (which are much weaker than the requirement that $V(x) \rightarrow \infty$ as $|x| \rightarrow \infty$), then (1.1) has infinitely many solutions.

4. Concentration of solutions

Theorem 4.1. *Suppose (V_1) , (V_2) , (P) are satisfied and $V^{-1}(0)$ has nonempty interior Ω . Let $u_m \in E$ be a solution of the equation*

$$-\Delta u + \lambda_m V(x)u = |u|^{p-2}u, \quad x \in \mathbb{R}^N. \tag{4.1}$$

If $\lambda_m \rightarrow \infty$ and $\|u_m\|_{\lambda_m} \leq C$ for some $C > 0$, then, up to a subsequence, $u_m \rightarrow \bar{u}$ in $L^p(\mathbb{R}^N)$, where \bar{u} is a weak solution of the equation

$$-\Delta u = |u|^{p-2}u, \quad x \in \Omega, \tag{4.2}$$

and $\bar{u} = 0$ a.e. in $\mathbb{R}^N \setminus V^{-1}(0)$. If moreover $V \geq 0$, then $u_m \rightarrow \bar{u}$ in E .

We note that $\bar{u} \in H_0^1(\Omega)$ if $V^{-1}(0) = \bar{\Omega}$ and $\partial\Omega$ is locally Lipschitz continuous (cf. [2]). Before proving the above theorem we point out some of its consequences.

Corollary 4.2. *Suppose (V_1) , (V_2) , (P) are satisfied, $V^{-1}(0)$ has nonempty interior, $V \geq 0$, $u_m \in E$ is a solution of (4.1), $\lambda_m \rightarrow \infty$ and $\Phi_{\lambda_m}(u_m)$ is bounded and bounded away from 0. Then the conclusion of Theorem 4.1 is satisfied and $\bar{u} \neq 0$.*

Proof. We have $\Phi_{\lambda_m}(u_m) = \frac{1}{2}\|u_m\|_{\lambda_m}^2 - \frac{1}{p}\|u_m\|_p^p$ and

$$\Phi_{\lambda_m}(u_m) = \Phi_{\lambda_m}(u_m) - \frac{1}{2}\langle \Phi'_{\lambda_m}(u_m), u_m \rangle = \left(\frac{1}{2} - \frac{1}{p}\right)\|u_m\|_p^p.$$

Hence $\|u_m\|_p$, and therefore also $\|u_m\|_{\lambda_m}$ is bounded. So the conclusion of Theorem 4.1 holds. Moreover, as $\|u_m\|_p$ is bounded away from 0, $\bar{u} \neq 0$. \square

Note that as a consequence of this corollary, if k is fixed, then any sequence of solutions u_m of (1.2) with $\lambda = \lambda_m \rightarrow \infty$ obtained in Theorem 3.4 contains a subsequence concentrating at some $\bar{u} \neq 0$. Moreover, it is possible to obtain a positive solution for each λ , either via Theorem 3.1 or by the mountain pass theorem. It follows that each sequence (u_m) of such solutions with $\lambda_m \rightarrow \infty$ has a subsequence concentrating at some \bar{u} which is positive in Ω . Corresponding to u_m are solutions $v_m = \varepsilon_m^{2/(p-2)} u_m$ of (1.3), where $\varepsilon_m^2 = \lambda_m^{-1}$. Then $v_m \rightarrow 0$ and $\varepsilon_m^{-2/(p-2)} v_m \rightarrow \bar{u}$. This should be compared with (iii) of Theorem 1 in [5] where it was shown that $\lim_{m \rightarrow \infty} \varepsilon_m^{-2/(p-2)} \|v_m\|_\infty > 0$.

It will become clear from the proof of Theorem 4.1 that if $V^{-1}(0)$ has empty interior, then $\bar{u} \equiv 0$ which is impossible under the assumptions of Corollary 4.2. Since $\sigma(-\Delta + \lambda V) \subset (a, \infty)$ for some $a > 0$ (independent of λ if λ is bounded away from 0), $u = 0$ is the only critical point of Φ_λ in B_r for some $r > 0$. Hence in this case $\Phi_{\lambda_m}(u_m) \rightarrow \infty$ and $\|u_m\| \rightarrow \infty$ if u_m is a nontrivial solution of (1.2) with $\lambda = \lambda_m \rightarrow \infty$.

If $V^- \neq 0$, we do not know whether $u_m \rightarrow \bar{u}$ in E or whether a result corresponding to Corollary 4.2 is true. However, if $V^{-1}(0)$ has empty interior, then it follows from Theorem 4.1 that either $u_m \rightarrow 0$ in $L^p(\mathbb{R}^N)$ or $\|u_m\|_{\lambda_m} \rightarrow \infty$.

Proof of Theorem 4.1. We modify the argument in [2]. Since $\lambda_m \geq 1$, $\|u_m\| \leq \|u_m\|_{\lambda_m} \leq C$. Passing to a subsequence, $u_m \rightharpoonup \bar{u}$ in E and $u_m \rightarrow \bar{u}$ in $L^p_{loc}(\mathbb{R}^N)$. Since $\langle \Phi'_{\lambda_m}(u_m), \varphi \rangle = 0$, we see that $\int_{\mathbb{R}^N} V(x) u_m \varphi \, dx \rightarrow 0$ and $\int_{\mathbb{R}^N} V(x) \bar{u} \varphi \, dx = 0$ for all $\varphi \in C_0^\infty(\mathbb{R}^N)$. Therefore $\bar{u} = 0$ a.e. in $\mathbb{R}^N \setminus V^{-1}(0)$.

We claim that $u_m \rightarrow \bar{u}$ in $L^p(\mathbb{R}^N)$. Assuming the contrary, it follows from P.L. Lions' vanishing lemma (see [12, Lemma I.1] or [14, Lemma 1.21]) that

$$\int_{B_\rho(x_m)} (u_m - \bar{u})^2 \, dx \geq \gamma$$

for some $(x_m) \subset \mathbb{R}^N$, $\rho, \gamma > 0$ and almost all m ($B_\rho(x)$ denotes the open ball of radius ρ and center x). Since $u_m \rightarrow \bar{u}$ in $L^2_{loc}(\mathbb{R}^N)$, $|x_m| \rightarrow \infty$. Therefore the measure of the set $B_\rho(x_m) \cap \{x \in \mathbb{R}^N : V(x) < b\}$ tends to 0 and

$$\|u_m\|_{\lambda_m}^2 \geq \lambda_m b \int_{B_\rho(x_m) \cap \{V \geq b\}} u_m^2 \, dx = \lambda_m b \left(\int_{B_\rho(x_m)} (u_m - \bar{u})^2 \, dx + o(1) \right) \rightarrow \infty,$$

a contradiction.

Let now $V \geq 0$. Since u_m satisfies (4.1), $\langle \Phi'_{\lambda_m}(u_m), \bar{u} \rangle = 0$ and $\bar{u}(x) = 0$ whenever $V(x) > 0$, it follows that

$$\|u_m\|^2 \leq \|u_m\|_{\lambda_m}^2 = \|u_m\|_p^p$$

and

$$\|\bar{u}\|^2 = \|\bar{u}\|_{\lambda_m}^2 = \|\bar{u}\|_p^p.$$

Hence $\limsup_{m \rightarrow \infty} \|u_m\|^2 \leq \|\bar{u}\|_p^p = \|\bar{u}\|^2$ and therefore $u_m \rightarrow \bar{u}$ in E . □

References

- [1] P. Bartolo, V. Benci and D. Fortunato, *Abstract critical point theorems and applications to some nonlinear problems with “strong” resonance at infinity*, *Nonlin. Anal.* 7 (1983), 981–1012.
- [2] T. Bartsch, A. Pankov and Z.Q. Wang, *Nonlinear Schrödinger equations with steep potential well*, *Comm. Contemp. Math.* 3 (2001), 549–569.
- [3] V. Benci, *On critical point theory of indefinite functionals in the presence of symmetries*, *Trans. Amer. Math. Soc.* 274 (1982), 533–572.
- [4] H. Brézis, E. Lieb, *A relation between pointwise convergence of functions and convergence of functionals*, *Proc. Amer. Math. Soc.* 88 (1983), 486–490.
- [5] J. Byeon, Z.Q. Wang, *Standing waves with a critical frequency for nonlinear Schrödinger equations, II*, *Calc. Var. PDE* 18 (2003), 207–219.
- [6] G. Cerami, G. Devillanova and S. Solimini, *Infinitely many bound states for some nonlinear scalar field equations*, *Calc. Var. PDE* 23 (2005), 139–168.
- [7] J. Chabrowski, *Variational Methods for Potential Operator Equations*, de Gruyter, Berlin 1997.
- [8] J. Chabrowski and A. Szulkin, *On the Schrödinger equation involving a critical Sobolev exponent and magnetic field*, *Top. Meth. Nonl. Anal.* 25 (2005), 3–21.
- [9] S.W. Chen and Y.Q. Li, *Nontrivial solution for a semilinear elliptic equation in unbounded domain with critical Sobolev exponent*, *J. Math. Anal. Appl.* 272 (2002), 393–406.
- [10] M. del Pino and P. Felmer, *Semi-classical states of nonlinear Schrödinger equations: a variational reduction method*, *Math. Ann.* 324 (2002), 1–32.
- [11] L. Jeanjean and K. Tanaka, *Singularly perturbed elliptic problems with superlinear or asymptotically linear nonlinearities*, *Calc. Var. PDE* 21 (2004), 287–318.
- [12] P.L. Lions, *The concentration-compactness principle in the calculus of variations. The locally compact case. Part I*, *Ann. IHP, Analyse Non Linéaire* 1 (1984), 109–145.
- [13] B. Simon, *Schrödinger semigroups*, *Bull. Amer. Math. Soc. (New Series)* 7, (1982), 447–526.
- [14] M. Willem, *Minimax Theorems*, Birkhäuser, Boston 1996.

Yanheng Ding
Institute of Mathematics
AMSS, Chinese Academy of Sciences
100080 Beijing
China

Andrzej Szulkin
Department of Mathematics
Stockholm University
106 91 Stockholm
Sweden

Multiparameter Elliptic Equations in Annular Domains

João Marcos do Ó, Sebastián Lorca and Pedro Ubilla

Dedicated to Djairo G. de Figueiredo on the occasion of his 70th birthday.

Abstract. Using fixed point theorems of cone expansion/compression type, the upper-lower solutions method and degree arguments, we study existence, non-existence and multiplicity of positive solutions for a class of second-order ordinary differential equations with multiparameters. We apply our results to semilinear elliptic equations in bounded annular domains with non-homogeneous Dirichlet boundary conditions. More precisely, we apply our main results to equations of the form

$$\begin{aligned} -\Delta u &= \lambda f(|x|, u) & \text{in } r_1 < |x| < r_2, \\ u(x) &= a & \text{on } |x| = r_1, \\ u(x) &= b & \text{on } |x| = r_2, \end{aligned}$$

where a, b and λ are non-negative parameters. One feature of the hypotheses on the nonlinearities that we consider is that they have some sort of local character.

Mathematics Subject Classification (2000). 35J60, 34B18.

Keywords. Elliptic equations, annular domains, positive radial solutions, upper-lower solutions method, fixed point theorem, degree theory.

1. Introduction

We establish existence, non-existence, and multiplicity of positive solutions for the second-order ordinary differential equation

$$\begin{aligned} -u'' &= \lambda g(t, u(t), a, b) \quad \text{in } (0, 1), \\ u(0) &= u(1) = 0, \end{aligned} \tag{P_{a,b,\lambda}}$$

where a, b and λ are non-negative parameters, and $g \in C([0, 1] \times [0, +\infty)^3, [0, +\infty))$ is a non-decreasing function in the last three variables.

Our first result treats the case where $\lambda = 1$ and the function g has a local superlinear growth at infinity. The behavior at zero of the function g may change according to the parameters a, b considered. (See assumptions (H_1) and (H_2) below.) We show that there exists a continuous curve Γ which splits the positive quadrant of the (a, b) -plane into two disjoint sets, say \mathcal{S} and \mathcal{R} , so that $(P_{a,b,1})$ has at least two positive solutions in \mathcal{S} ; at least one positive solution on the boundary of \mathcal{S} ; and no positive solutions in \mathcal{R} . (See Theorem 1.1 below.)

Our second result treats the case where the function g has sublinear growth at infinity. Again, the behavior at zero of the function g may change according to the parameters a, b considered. We show that $(P_{a,b,\lambda})$ has at least one positive solution, for all $a, b, \lambda > 0$. Further, we show that there exists $\rho > 0$ such that $(P_{a,b,\lambda})$ has at least three positive solutions, for all $0 < |(a, b)| < \rho$ and λ sufficiently large. (See Theorem 1.2 below.)

We subsequently give applications of our main results to semilinear elliptic equations in annular domains.

The approach taken to prove our main results is based on a well known fixed point theorem of cone expansion and compression type, the upper-lower solutions method and some topological degree arguments.

We will assume the following six basic hypotheses:

(H_0) $g \in C([0, 1] \times [0, +\infty)^3, [0, +\infty))$ is a non-decreasing function in the last three variables. In other words,

$$g(t, u_1, a_1, b_2) \leq g(t, u_2, a_2, b_2)$$

whenever $(u_1, a_1, b_1) \leq (u_2, a_2, b_2)$. The above inequality is understood inside every component. Furthermore, there exist constants $0 < \delta_0 < \varepsilon_0 < 1$ such that, for all $t \in [\delta_0, \varepsilon_0]$, we have $g(t, 0, a, b) > 0$ whenever $a + b > 0$.

(H_1) There exist constants $0 < \delta_1 < \varepsilon_1 < 1$ such that, for all $(a, b) \in [0, +\infty)^2 \setminus \{(0, 0)\}$, we have

$$\lim_{u \rightarrow 0} \frac{g(t, u, a, b)}{u} = +\infty \quad \text{uniformly in } t \in [\delta_1, \varepsilon_1].$$

(H_2) $\lim_{|(u, a, b)| \rightarrow 0} \frac{g(t, u, a, b)}{|(u, a, b)|} = 0$ uniformly in $t \in [0, 1]$. Here we use the notation $|(z_1, z_2, z_3)| = (z_1^2 + z_2^2 + z_3^2)^{1/2}$.

(H₃) There exist constants $0 < \delta_2 < \varepsilon_2 < 1$ such that

$$\lim_{u \rightarrow +\infty} \frac{g(t, u, 0, 0)}{u} = +\infty \quad \text{uniformly in } t \in [\delta_2, \varepsilon_2].$$

(H₄) There exist constants $0 < \delta_3 < \varepsilon_3 < 1$ such that

$$\lim_{|(a,b)| \rightarrow +\infty} g(t, 0, a, b) = +\infty \quad \text{uniformly in } t \in [\delta_3, \varepsilon_3].$$

(H₅) For all $(a, b) \in [0, +\infty)^2$, we have

$$\lim_{u \rightarrow +\infty} \frac{g(t, u, a, b)}{u} = 0 \quad \text{uniformly in } t \in [0, 1].$$

(H₆) There exist constants $R > 0$ and $0 < \delta_4 < \varepsilon_4 < 1$ such that

$$0 < g(t, u, 0, 0), \quad \text{for all } 0 < u < R \text{ and } t \in [\delta_4, \varepsilon_4].$$

The following are our main results, which will be proved in Sections 2 and 3.

Theorem 1.1 (Superlinear case at $+\infty$). *Suppose that $\lambda = 1$ and that $g(t, u, a, b)$ satisfies assumptions (H₀) through (H₄). Then there exist $\bar{a} > 0$ and a non-increasing continuous function $\Gamma : [0, \bar{a}] \rightarrow [0, +\infty)$ so that, for all $a \in [0, \bar{a}]$, we have:*

- (i) $(P_{a,b,1})$ has at least one positive solution if $0 \leq b \leq \Gamma(a)$.
- (ii) $(P_{a,b,1})$ has no solution if $b > \Gamma(a)$.
- (iii) $(P_{a,b,1})$ has a second positive solution if $0 < b < \Gamma(a)$.

Theorem 1.2 (Sublinear case at $+\infty$). *Suppose that $g(t, u, a, b)$ satisfies assumptions (H₀) through (H₂), as well as assumptions (H₅) and (H₆). Then:*

- (i) $(P_{a,b,\lambda})$ has at least one positive solution for all $a, b, \lambda > 0$.
- (ii) There exists a positive constant ρ sufficiently small such that, for all $0 < |(a, b)| < \rho$, $(P_{a,b,\lambda})$ has at least three positive solutions for λ sufficiently large.

Remark 1.3. Observe the local character of assumptions (H₁), (H₃), (H₄), and (H₆) on the nonlinearity g in the variable t . More precisely, in this paper some sort of sublinearity and some sort of superlinearity is required to hold uniformly in t only on open sub-intervals of $(0, 1)$ which may be small and possibly disjoint.

Our main results may be applied to several classes of elliptic problems. For example, we may apply our results to the semilinear elliptic equation

$$\begin{aligned} -\Delta u &= \lambda \hat{f}(|x|, u) & \text{in } r_1 < |x| < r_2, \\ u(x) &= a & \text{on } |x| = r_1, \\ u(x) &= b & \text{on } |x| = r_2, \end{aligned} \tag{Q_{a,b,\lambda}}$$

where $0 < r_1 < r_2$ and $N \geq 3$. For instance, in the case $\hat{f}(|x|, u) = c(|x|)f(u)$, where $c : [r_1, r_2] \rightarrow [0, +\infty)$ is a non-negative, non-trivial continuous function and the nonlinearity f is a superlinear continuous function both at zero and infinity, we may apply Theorem 1.1. Note that a simpler model is given by $f(u) = u^p$,

with $p > 1$. The case $f(u) = u^{(N+2)/(N-2)}$, $c \equiv 1$, and $a = 0$ was studied by C. Bandle and L. A. Peletier [1]. This result was subsequently improved by M. G. Lee and S. S. Lin [8]. In fact, using Shooting Methods, the results of [1] were extended by Lee and Lin to nonlinearities f that are convex and superlinear at both zero and infinity. Using degree arguments and the upper-lower solutions method, D. D. Hai extends and complements some of the results of [1, 8] to locally Lipschitz continuous nonlinearities. (See [5, Theorem 3.7].)

Our multiplicity result is an improvement because $(P_{a,b,\lambda})$ is not necessarily autonomous, and we do not impose either local Lipschitz continuity assumptions or convexity on the nonlinearity f . In addition, by Theorem 1.2, we obtain the existence of three positive solutions of $(Q_{a,b,\lambda})$, a type of result not yet found in the literature. As an application of Theorem 1.2, a simple model is given by $f(u) = u^p/(1 + u^q)$, with $\max\{1, q\} < p < q + 1$.

The paper is organized as follows. Section 2 contains preliminary results. Sections 3, 4 are devoted to proving Theorems 1.1, 1.2, respectively. Finally, in Section 5 we give more examples and remarks.

Notation. Here is a brief summary of the notation we make use of.

We denote the closed ball of radius R centered at the point $p \in X$ by $B[p, R] = \{x \in X : |x| \leq R\}$, and denote the open ball with radius R centered at the point $p \in X$ by $B(p, R)$. The *mapping degree* for the equation $F(x) = y$, for $x \in A$, is denoted by $\text{deg}(F, A, y)$.

2. Preliminary results

In the next section using the lower and upper solution method and fixed point techniques we will prove Theorem 1.1. For this purpose we observe that if u is a solution of $(P_{a,b,\lambda})$, then for all $t \in [0, 1]$,

$$u(t) = (1 - t)\lambda \int_0^1 \tau g(\tau, u(\tau), a, b) \, d\tau + \lambda \int_t^1 (t - \tau)g(\tau, u(\tau), a, b) \, d\tau,$$

or, equivalently,

$$u(t) = \lambda \int_0^1 K(t, \tau)g(\tau, u(\tau), a, b) \, d\tau$$

where

$$K(t, \tau) = \begin{cases} (1 - t)\tau, & \tau < t, \\ (1 - \tau)t, & \tau \geq t. \end{cases}$$

Thus, solutions of $(P_{a,b,\lambda})$ correspond to the fixed points of the operator

$$Tu(t) = \lambda \int_0^1 K(t, \tau)g(\tau, u(\tau), a, b) \, d\tau \tag{2.1}$$

defined on the Banach space $X = C([0, 1], \mathbb{R})$ endowed with the usual norm $\|u\|_\infty := \sup_{t \in [0, 1]} |u(t)|$.

The following fixed point theorem in cones is due to Krasnoselskii (see [2, 3, 4, 7]).

Lemma 2.1. *Let X be a Banach space with norm $|\cdot|$, and let $C \subset X$ be a cone in X . For $R > 0$, define $C_R = C \cap B[0, R]$. Assume that $F : C_R \rightarrow C$ is a completely continuous map and that there exists $0 < r < R$ such that*

$$\begin{aligned} |Fx| < |x|, \quad x \in \partial C_r \quad \text{and} \quad |Fx| > |x|, \quad x \in \partial C_R, \text{ or} \\ |Fx| > |x|, \quad x \in \partial C_r \quad \text{and} \quad |Fx| < |x|, \quad x \in \partial C_R, \end{aligned}$$

where $\partial C_R = \{x \in C : |x| = R\}$. Then F has a fixed point $u \in C$ with $r < |u| < R$.

Let C be the cone defined by

$$C = \{u \in C[0, 1] : u \text{ is concave and } u(0) = u(1) = 0\}.$$

Using the concavity of the function $u \in C$ it is not difficult to obtain the following result.

Lemma 2.2. *For each $u \in C$ and $\alpha, \beta \in (0, 1)$ with $\alpha < \beta$, we have*

$$\inf_{t \in [\alpha, \beta]} u(t) \geq \alpha(1 - \beta) \|u\|_\infty.$$

Remark 2.3. In this work we mainly use fixed points in Cones and Topological Degree. In this context Lemma 2.2 is crucial in order to obtain estimates of expansion/compression type as well as when we want to establish a priori bounds.

Lemma 2.4. *The operator $T : X \rightarrow X$ is completely continuous and $T(C) \subset C$.*

Proof. The proof of this lemma is standard and we include here only the main ideas for completeness. The complete continuity of T follows from The Arzela-Ascoli theorem. It is easy to see that Tu is twice differentiable on $(0, 1)$ with the second derivative negative. This implies that $T(C) \subset C$. □

3. Proof of Theorem 1.1 (Superlinear case at $+\infty$)

In this section we combine the fixed point theorem, upper-lower solutions method and degree arguments to prove Theorem 1.1. We recall that through this section $\lambda = 1$.

3.1. The first positive solution for Problem $(P_{a,b,1})$

Lemma 3.1. *If $g(t, u, a, b)$ satisfies (H_0) , (H_1) and (H_2) , then there exist positive parameters a_0 and b_0 such that $(P_{a_0, b_0, 1})$ has at least one positive solution.*

Proof. Let $u \in C$ with $\|u\|_\infty = R > 0$. In view of assumption (H_0) , for all $t \in [0, 1]$ we have

$$Tu(t) = \int_0^1 K(t, \tau)g(\tau, u(\tau), a, b)d\tau \leq \max_{(t, \tau) \in [0, 1]^2} K(t, \tau) \max_{\tau \in [0, 1]} g(\tau, R, a, b).$$

Hence, using condition (H_2) , we can take $a_0, b_0, R > 0$ sufficiently small such that

$$\|Tu\|_\infty < \|u\|_\infty \text{ if } \|u\|_\infty = R. \tag{3.2}$$

Next, using assumption (H_1) , given $M > 0$ there exist $r_1 \in (0, R)$ such that,

$$g(t, u, a_0, b_0) \geq Mu, \text{ for all } (t, u) \in [\delta_1, \varepsilon_1] \times [0, r_1]. \tag{3.3}$$

From Lemma 2.2, for all $u \in C$ we have

$$u(t) \geq (1 - \varepsilon_1)\delta_1 \|u\|_\infty, \text{ for all } t \in [\delta_1, \varepsilon_1]. \tag{3.4}$$

This estimate in combination with (3.3), and taking M sufficiently large we have

$$\|Tu\|_\infty > \|u\|_\infty \text{ if } \|u\|_\infty = r_1. \tag{3.5}$$

Therefore, in view of estimates (3.2) and (3.5), we can apply Lemma 2.1 to get a fixed point $u \in C$ with $r_1 < \|u\| < R$. Finally, using the maximum principle we obtain that u is positive. □

The following is a non-existence result.

Lemma 3.2. *If $g(t, u, a, b)$ satisfies (H_3) and (H_4) , then there exists $c_0 > 0$ such that for all $(a, b) \in [0, +\infty)^2$ with $|(a, b)| > c_0$, $(P_{a,b,1})$ has no positive solutions.*

Proof. Assume by contradiction that there exists a sequence (a_n, b_n) with $|(a_n, b_n)| \rightarrow +\infty$ such that for each n $(P_{a_n, b_n, 1})$ possesses a positive solution $(u_n) \in C$. By assumption (H_4) , given $M > 0$, there exists $c_0 > 0$ such that for all $(a, b) \in [0, +\infty)^2$ with $|(a, b)| \geq c_0$, we have

$$g(t, u, a, b) \geq M, \text{ for all } t \in [\delta_3, \varepsilon_3] \text{ and } u \geq 0. \tag{3.6}$$

Thus,

$$\begin{aligned} u_n(t) &= \int_0^1 K(t, \tau)g(\tau, u_n(\tau), a_n, b_n) d\tau \\ &\geq \int_{\delta_3}^{\varepsilon_3} K(t, \tau)g(\tau, u_n(\tau), a_n, b_n) d\tau, \end{aligned}$$

which implies that, for n sufficiently large,

$$u_n(t) \geq M \int_{\delta_3}^{\varepsilon_3} K(t, \tau) d\tau.$$

Hence

$$\|u_n\|_\infty \geq M \max_{t \in [0, 1]} \int_{\delta_3}^{\varepsilon_3} K(t, \tau) d\tau.$$

Since in (3.6) we may choose an arbitrary constant M , we have that (u_n) is an unbounded sequence in X .

On the other hand, by using assumption (H_3) , we have that given $M > 0$ there exists $R > 0$ such that for all $t \in [\delta_2, \varepsilon_2]$ and $a, b \geq 0$,

$$g(t, u, a, b) \geq Mu, \text{ for all } u \geq R. \tag{3.7}$$

Using Lemma 2.2, for n sufficiently large, we get

$$u_n(t) \geq M(1 - \varepsilon_2)\delta_2 \|u_n\|_\infty \int_{\delta_2}^{\varepsilon_2} K(t, \tau) \, d\tau.$$

Hence

$$1 \geq M(1 - \varepsilon_2)\delta_2 \max_{t \in [0,1]} \int_{\delta_2}^{\varepsilon_2} K(t, \tau) \, d\tau,$$

which is a contradiction with the fact that M can be chosen arbitrarily large. The proof of Lemma 3.2 is now complete. \square

Remark 3.3. As an immediate consequence of Lemma 3.2, we have a priori estimate for positive solutions of $(P_{a,b,1})$, more precisely, there exists $k_0 > 0$ independent of (a, b) such that $\|u\|_\infty \leq k_0$, for all $u \in X$ positive solutions of $(P_{a,b,1})$.

Next, using the upper-lower solutions method we may establish the following result.

Lemma 3.4. *If $g(t, u, a, b)$ satisfies (H_0) and $(P_{a,b,1})$ has a positive solution, then for all $(0, 0) \leq (c, d) \leq (a, b)$, $(P_{c,d,1})$ has a positive solution provided that $c+d > 0$.*

Proof. Since the function $g(t, u, a, b)$ is nondecreasing in the last two variables we have that the solution u of $(P_{a,b,1})$ is a upper-solution of $(P_{c,d,1})$, while the null function is a lower solution for this problem. Therefore, using the classical lower and upper solution method we have that $(P_{c,d})$ has a positive solution. \square

Let us define

$$\bar{a} := \sup\{a > 0 : (P_{a,b,1}) \text{ has a positive solution for some } b > 0\}.$$

From Lemma 3.2 it follows immediately that $0 < \bar{a} < +\infty$. It is easy to see, using the lower and upper solution method that for all $a \in (0, \bar{a})$ there exists $b > 0$ such that $(P_{a,b,1})$ has a positive solution. Thus we may define the function $\Gamma : [0, \bar{a}] \rightarrow [0, +\infty)$ given by

$$\Gamma(a) := \sup\{b > 0 : (P_{a,b,1}) \text{ has a positive solution}\}.$$

As a consequence of Lemma 3.4, we obtain that Γ is a continuous and nonincreasing function. Therefore, it is easy to see by the definition of the function Γ that $(P_{a,b,1})$ has at least one positive solution if $0 \leq b \leq \Gamma(a)$ and it has no positive solutions when $b > \Gamma(a)$.

3.2. The second positive solution for Problem $(P_{a,b,1})$

Now, we are working to prove the existence of a second positive solution of $(P_{a,b,1})$ when $0 < b < \Gamma(a)$. In this case, according to conclusions above we have positive solutions u_1 and \bar{u} of $(P_{a,b,1})$ and $(P_{a,\Gamma(a),1})$ respectively. Using a combination of maximum principle and the monotonicity of the function $g(t, u, a, b)$ in the second variable we may suppose that

$$0 < u_1 < \bar{u}, \quad 0 < u'_1(0) < \bar{u}'(0) \quad \text{and} \quad u'_1(1) < \bar{u}'(1) < 0.$$

Now we consider the Banach space X_1 given by

$$X_1 := \{u \in C^1[0, 1] : u(0) = u(1) = 0\},$$

endowed with the norm $\|u\|_1 := \|u\|_\infty + \|u'\|_\infty$. Moreover, we consider the following open subset of X_1 given by

$$\mathcal{A} := \{u \in X_1 : 0 < u < \bar{u}, 0 < u'(0) < \bar{u}'(0), u'(1) < \bar{u}'(1) < 0 \text{ and } \|u\|_1 < R_1\},$$

where R_1 is chosen such that $\|u_1\|_1 < R_1$.

Let us consider the operator $\mathcal{S}_{(a,b)} : X_1 \rightarrow X_1$ given by

$$\mathcal{S}_{(a,b)}u(t) = \int_0^1 K(t, \tau)g(\tau, u(\tau), a, b) d\tau.$$

We notice that if there exists a fixed point of $\mathcal{S}_{(a,b)}$ on $\partial\mathcal{A}$, then we have a second positive solution of $(P_{a,b,1})$, otherwise we will obtain the existence of our second positive solution as a consequence of the following result.

Lemma 3.5. *Suppose that $\mathcal{S}_{(a,b)}$ has no fixed point on $\partial\mathcal{A}$ and assume that $0 < b < \Gamma(a)$. By using the notation above, we have:*

- (i) $\text{deg}(Id - \mathcal{S}_{(a,b)}, \mathcal{A}, 0) = 1$
- (ii) *There exists $\bar{R} > R_1$ such that $\text{deg}(Id - \mathcal{S}_{(a,b)}, B_{X_1}(0, \bar{R}), 0) = 0$.*

Proof. Let us define

$$\bar{g}(t, v, a, b) := \begin{cases} g(t, \bar{u}(t), a, b) & \text{if } \bar{u}(t) < v, \\ g(t, v, a, b) & \text{if } 0 \leq v \leq \bar{u}(t), \\ 0 & \text{if } v < 0, \end{cases}$$

and $\bar{\mathcal{S}}_{(a,b)} : X_1 \rightarrow X_1$ given by

$$(\bar{\mathcal{S}}_{(a,b)}u)(t) = \int_0^1 K(t, \tau)\bar{g}(\tau, u(\tau), a, b) d\tau.$$

It is easy to see that this operator $\bar{\mathcal{S}}_{(a,b)}$ satisfies the following properties:

- (a) $\bar{\mathcal{S}}_{(a,b)}$ is a completely continuous operator;
- (b) if u is a fixed point of $\bar{\mathcal{S}}_{(a,b)}$, then u is a fixed point of $\mathcal{S}_{(a,b)}$ with $0 \leq u \leq \bar{u}$;
- (c) If $u = \lambda \bar{\mathcal{S}}_{(a,b)}u$ with $0 \leq \lambda \leq 1$ then $\|u\|_1 \leq C_3$, where C_3 does not depend on λ and $u \in X_1$.

According to the a priori estimate property of assertion (c), there exists $R_2 > R_1$ so that

$$\text{deg}(Id - \bar{\mathcal{S}}_{(a,b)}, B_{X_1}(0, R_2), 0) = 1. \tag{3.8}$$

By the Maximum Principle, the operator $\bar{\mathcal{S}}_{(a,b)}$ has no fixed points in $\overline{B(0, R_2)} \setminus \mathcal{A}$. By hypothesis, $\bar{\mathcal{S}}_{(a,b)}$ has no fixed points on $\partial\mathcal{A}$. Thus the topological degree of Leray-Schauder is defined for the equation $(Id - \bar{\mathcal{S}}_{(a,b)})(x) = 0$, for $x \in \mathcal{A}$. It follows from (3.8) and the excision property of mapping degree that

$$\text{deg}(Id - \bar{\mathcal{S}}_{(a,b)}, \mathcal{A}, 0) = 1.$$

Since $S_{(a,b)}(u) = \overline{S}_{(a,b)}(u)$, for $u \in \partial\mathcal{A}$, we obtain part (i).

Next, using (3.4) and assumption (H_3) (see also (3.7)) we obtain an a priori estimate \overline{R} which can be taken larger than R_1 for solutions of the equation

$$u = S_{(a,b)}u, \quad u \in X_1 \tag{3.9}$$

which does not depend on the parameters a and b . Let $(\overline{a}, \overline{b})$ be such that $|(\overline{a}, \overline{b})|$ is sufficiently large so that $(P_{a,b,1})$ has no positive solutions (see Lemma 3.2). Thus

$$\text{deg}(Id - \mathcal{S}_{(\overline{a}, \overline{b})}, B(0, \overline{R}), 0) = 0.$$

Hence, by the homotopy invariance property of the mapping degree,

$$\text{deg}(Id - \mathcal{S}_{(a,b)}, B(0, \overline{R}), 0) = 0.$$

The proof of Lemma 3.5 is now complete. □

Finally, Lemma 3.5 and the excision property of the topological degree imply

$$\text{deg}(Id - \mathcal{S}_{(a,b)}, B(0, \overline{R}) \setminus \overline{\mathcal{A}}, 0) = -1,$$

hence we have a second solution of $(P_{a,b,1})$. The proof of Theorem 1.1 is complete.

4. Proof of Theorem 1.2

In this section, we apply Lemma 2.1 to obtain three solutions of Problem $(P_{a,b,\lambda})$ when $g(t, u, a, b)$ is sublinear at infinity.

We now present two lemmas which lead to the proof of Theorem 1.2.

Lemma 4.1. *Assume that hypothesis (H_1) holds. Then given $(a, b) \in [0, +\infty)^2 \setminus \{(0, 0)\}$, there exists $R_1 > 0$ sufficiently small so that, for all $u \in \partial C_{R_1}$, we have*

$$\|Tu\|_\infty > \|u\|_\infty.$$

Proof. According to hypothesis (H_1) , for each $M > 0$, there exists $R_1 > 0$ so that, for all $t \in [\delta_1, \varepsilon_1]$, we have

$$g(t, u, a, b) \geq Mu, \quad \text{for each } u \in [0, R_1].$$

Therefore, for all $u \in C_R$,

$$\begin{aligned} \|Tu\|_\infty &\geq \lambda \int_0^1 K(1/2, \tau) g(\tau, u(\tau), a, b) \, d\tau \\ &\geq \lambda M \int_{\delta_1}^{\varepsilon_1} K(1/2, \tau) u(\tau) \, d\tau \\ &\geq \lambda \delta_1 (1 - \varepsilon_1) M \|u\|_\infty \int_{\alpha_1}^{\beta_1} K(1/2, \tau) \, d\tau. \end{aligned}$$

Taking $M > 0$ sufficiently large completes the proof of Lemma 4.1. □

Lemma 4.2. *Assume condition (H_6) . Then given $(a, b) \in [0, +\infty)^2$ and $R_1 > 0$, there exists $R_2 > R_1$ such that, for all $u \in \partial C_{R_2}$,*

$$\|Tu\|_\infty < \|u\|_\infty.$$

Proof. Let $(a, b) \in [0, +\infty)^2$. According to assumption (H_5) , given $\varepsilon > 0$, there exists $R_2 > R_1$ such that, for all $u \geq R_2$, we have

$$g(t, u, a, b) \leq \varepsilon u.$$

Thus

$$\begin{aligned} (Tu)(t) &= \lambda \int_0^1 K(t, \tau)g(\tau, u(\tau), a, b) \, d\tau \\ &\leq \lambda \int_0^1 K(t, \tau)g(\tau, \|u\|_\infty, a, b) \, d\tau \\ &\leq \lambda\varepsilon\|u\|_\infty \int_0^1 K(t, \tau) \, d\tau. \end{aligned}$$

Taking $\varepsilon > 0$ sufficiently small completes the proof. □

Proof of Theorem 1.2. Part (i) of Theorem 1.2 results from Lemmas 4.1, 4.2 and Lemma 2.1. For Part (ii), according to assumption (H_2) , there exist positive constants sufficiently small ρ, R_3 so that, for all $0 < |(a, b)| < \rho$, we have

$$\|Tu\|_\infty < \|u\|_\infty, \text{ for } u \in \partial C_{R_3}.$$

Now it follows from assumptions (H_0) and (H_6) that, for all $u \in \partial C_R$, we have

$$\begin{aligned} (Tu)(t) &= \lambda \int_0^1 K(t, \tau)g(\tau, u(\tau), a, b)d\tau \\ &\geq \lambda \int_{\delta_4}^{\varepsilon_4} K(t, \tau)g(\tau, \|u\|_\infty(1 - \varepsilon_4)\delta_4, a, b)d\tau \\ &\geq \lambda \int_{\delta_4}^{\varepsilon_4} K(t, \tau)g(\tau, R(1 - \varepsilon_4)\delta_4, 0, 0)d\tau. \\ &\geq \lambda C_1. \end{aligned}$$

where C_1 depends only on R . Thus, there exists $\lambda_1 > 0$ sufficiently large such that, for all $\lambda > \lambda_1$, we have

$$\|Tu\|_\infty > \|u\|_\infty, \text{ for all } u \in \partial C_R \text{ and } a, b \geq 0.$$

We may choose the constants R_1, R_2 and R_3 so that $R_1 < R_3 < R < R_2$. Applying Lemma 2.1 we obtain three fixed points of the operator F in C satisfying

$$R_1 < \|u_1\|_\infty < R_3 < \|u_2\|_\infty < R < \|u_3\|_\infty < R_2,$$

whence the Theorem. □

5. Applications

In this section we will state some applications of Theorems 1.1 and 1.2 . Indeed, let us consider the following examples in annular domains. Through this section, we assume that $N \geq 3$.

Example 5.1. We consider the problem

$$\begin{aligned} -\Delta u &= \alpha c_1(|x|) + c_2(|x|)(\beta + u^p) \exp(\zeta u^q) & \text{in } r_1 < |x| < r_2, \\ u(x) &= 0 & \text{on } |x| = r_1, \\ u(x) &= 0 & \text{on } |x| = r_2, \end{aligned} \tag{5.10}$$

where c_1, c_2 are nonnegative continuous functions, $0 < r_1 < r_2$, $\alpha, \beta \geq 0$; $p > 1$; $q \geq 0$ and $\zeta > 0$. Moreover, we suppose that there exists $t_0 \in (r_1, r_2)$ such that $c_1(t_0)$ and $c_2(t_0)$ are positive real numbers. Performing the change of variable $t = a(r)$ with

$$a(r) = -\frac{A}{r^{N-2}} + B,$$

where

$$A = \frac{(r_1 r_2)^{N-2}}{r_2^{N-2} - r_1^{N-2}} \text{ and } B = \frac{r_2^{N-2}}{r_2^{N-2} - r_1^{N-2}},$$

we obtain the equivalent problem

$$\begin{aligned} -u'' &= g(t, u(t), a, b) & \text{in } (0, 1) \\ u(0) &= u(1) = 0 \end{aligned} \tag{5.11}$$

where $g(t, u, a, b) = \alpha^p d_1(t) + d_2(t)(b^p + u^p) \exp(\zeta u^q)$, $\alpha = a^p$, $\beta = b^p$ and

$$d_i(t) = (1 - N)^2 \frac{A^{2/(N-2)}}{(B - t)^{2(N-1)/(N-2)}} c_i \left(\left(\frac{A}{B - t} \right)^{1/(N-2)} \right), \text{ for } i = 1, 2.$$

It is not difficult to verify that (5.11) satisfies the hypotheses of Theorem 1.1. Hence, we may conclude that there exists $\bar{\alpha} > 0$ and a function $\Gamma : [0, \bar{\alpha}] \rightarrow [0, +\infty)$ satisfying

- (i) If $\beta = 0$ or $\beta = \Gamma(\alpha)$, (5.11) has at least one positive solution.
- (ii) If $0 < \beta < \Gamma(\alpha)$, (5.11) has at least two positive solutions.
- (iii) If $\beta > \Gamma(\alpha)$, (5.11) has no positive solutions.

Example 5.2. We consider the problem

$$\begin{aligned} -\Delta u &= \lambda c(|x|)f(u) & \text{in } r_1 < |x| < r_2, \\ u(x) &= a & \text{on } |x| = r_1, \\ u(x) &= b & \text{on } |x| = r_2, \end{aligned} \tag{5.12}$$

where a, b are nonnegative parameters, $0 < r_1 < r_2$, $c : [0, +\infty) \rightarrow [0, +\infty)$ is continuous function and the nonlinearity f is a nondecreasing continuous function satisfying

- (i) $\lim_{u \rightarrow 0} \frac{f(u)}{u} = 0$.
- (ii) $\lim_{u \rightarrow +\infty} \frac{f(u)}{u} = +\infty$.

Then the conclusions of Theorem 1.1 are true. Indeed, coming from a similar way to the previous example, it is possible to verify that equation (5.12) is equivalent to

$$\begin{aligned} -u'' &= d(t) f(u + (1 - t)a + tb) \quad \text{in } (0, 1) \\ u(0) &= u(1) = 0 \end{aligned} \tag{5.13}$$

where $g(t, u, a, b) = d(t) f(u + (1 - t)a + tb)$ verifies the hypothesis of Theorem 1.1 with

$$d(t) = (1 - N)^2 \frac{A^{2/(N-2)}}{(B - t)^{2(N-1)/(N-2)}} c\left(\left(\frac{A}{B - t}\right)^{1/(N-2)}\right).$$

We observe that Theorem 1.2 may be applied in Equation (5.12) assuming the hypothesis (i) above and moreover assuming the following sub-linear hypothesis at infinity

$$(iii) \lim_{u \rightarrow +\infty} \frac{f(u)}{u} = 0 .$$

Finally, we notice that Theorem 1.2 may be applied to establish the existence and multiplicity (three) of solutions for the following two equations below.

Example 5.3. We consider the problem

$$\begin{aligned} -\Delta u &= \lambda (c_1(|x|)u^{p_1} + 1)\Phi(c_2(|x|)u^{p_2}) \quad \text{in } r_1 < |x| < r_2, \\ u(x) &= a \quad \text{on } |x| = r_1, \\ u(x) &= b \quad \text{on } |x| = r_2, \end{aligned} \tag{5.14}$$

where $p_1 < 1 < p_2$, $c_i : [r_1, r_2] \rightarrow [0, +\infty)$ for $i = 1, 2$ are nontrivial and nonnegative continuous functions. Furthermore, it is assumed that $\Phi : [0, +\infty) \rightarrow [0, +\infty)$ is a nondecreasing continuous function satisfying

$$\lim_{u \rightarrow 0} \frac{\Phi(u)}{u} = \hat{c}_1 \geq 0 \quad \text{and} \quad \lim_{u \rightarrow +\infty} \Phi(u) = \hat{c}_2 > 0.$$

Example 5.4. We consider the problem

$$\begin{aligned} -\Delta u &= \lambda \frac{c_1(|x|)u^{p_3}}{1 + c_2(|x|)u^{p_4}} \quad \text{in } r_1 < |x| < r_2, \\ u(x) &= a \quad \text{on } |x| = r_1, \\ u(x) &= b \quad \text{on } |x| = r_2, \end{aligned} \tag{5.15}$$

where $1 < p_3 < 1 + p_4$ and the function $c_i(|x|)$ are like in the example above, verifying in addition that the intersection of its supports is not empty.

Remark 5.1. We note that 5.12 belongs to the frame of autonomous elliptic equations perturbed by a weight $c(|x|)$. When the weight is nonnegative and nontrivial on any compact subinterval in $(0, 1)$, this type of problems has been considered in the literature by several authors (see for example [6] and [9]). We note that here the weight may vanish in parts of the annulus. In addition, Equations (5.10), (5.14) and (5.15) correspond to elliptic equations strongly non-autonomous. Finally, we notice that another novelty here is the multiplicity result of three positive solutions for the semi-linear elliptic equations in bounded annular domains with nonhomogeneous boundary conditions.

Acknowledgement. Part of this work also was done while the third author was visiting Arica/Chile on 2003. He thanks the faculty and staff of the Universidad de Tarapaca for their great hospitality during his visit.

References

- [1] C. Bandle and L. A. Peletier, Nonlinear elliptic problems with critical exponent in shrinking annuli, *Math. Ann.* **280** (1988), 1-19.
- [2] K. Deimling, *Nonlinear Functional Analysis*, Springer-Verlag, New York, 1985.
- [3] D. G. de Figueiredo, *Positive solutions of semilinear elliptic equations*, Lecture Notes in Mathematics 957, Springer-Verlag, Berlin–Heidelberg–New York, 1982, pp. 34–87.
- [4] D. Guo and V. Lakshmikantham, *Nonlinear Problem in Abstract Cones*, Academic Press, Orlando, FL, 1988.
- [5] D. D. Hai, Positive solutions for semilinear elliptic equations in annular domains, *Nonlinear Analysis* **37** (1999), 1051-1058.
- [6] L. Kong and J. Wang, Multiple positive solutions for the one-dimensional p-Laplacian, *Nonlinear Analysis* **42** (2000), 1327-1333.
- [7] M. A. Krasnosel'skii, *Topological methods in the theory of nonlinear integral equations*. Pergamon Press, The Macmillan Co., New York, 1964.
- [8] M. G. Lee and S. S. Lin, On the positive solution for semilinear elliptic equations on annular domain with non-homogeneous Dirichlet boundary conditions, *J. Math. Anal. Appl.* **181** (1994), 348-361.
- [9] Y. Liu, Multiple positive solutions of singular boundary value problem for the one-dimensional p-Laplacian, *Indian J. pure appl. Math.* **33** (2002), 1541-1555.

João Marcos do Ó¹
Departamento de Matemática
Universidade Federal da Paraíba
58059-900 João Pessoa – PB
Brazil
e-mail: jmbo@mat.ufpb.br

Sebastián Lorca
Casilla 7-D
Arica
Chile
e-mail: slorca@uta.cl

Pedro Ubilla
Universidad de Santiago de Chile
Casilla 307
Correo 2, Santiago
Chile
e-mail: pubilla@usach.cl

¹Corresponding author

Variational Principle for the Seiberg–Witten Equations

Celso Melchiades Doria

Abstract. Originally, the Seiberg–Witten equations were described to be dual to the Yang–Mills equation. The aim of this article is to present a Variational Principle for the *SW*-equation and some of their analytical properties, including the Palais-Smale Condition.

Mathematics Subject Classification (2000). 58J05, 58E50.

Keywords. Connections, gauge fields, 4-manifolds.

1. Introduction

In november of 1994, Edward Witten gave a lecture at MIT about $N = 2$ Supersymmetric Quantum Field Theory and the ideas concerning the *S*-duality developed in a joint work with Seiberg in [15]. In order to please the mathematicians in the audience, he applied the new ideas to the Yang–Mills Theory to show them a new pair of 1st-order PDE, named *SW*-monopole equation, and conjectured that the *SW*-theory is dual to the Yang–Mills theory; the duality being at the quantum level. A necessary condition for the duality is the equality of the expectation values of both theories. In topology, this means that for a fixed 4-manifold X there is a formula, conjectured by Witten in [20], where its Seiberg–Witten invariants are equal to the Donaldson invariants up to the factor $2^{2+\frac{1}{4}(7\chi(X)+11\tau(X))}$. After 10 years, it is believed that the conjecture is true, some tour the force has been done in [11] to prove it, but in its generality it is still an open question. This new pair of equations has a simpler analytical nature than the Yang–Mills equations. Even though the open question, and the fact that the physical meaning of the Seiberg–Witten equations (*SW* _{α} -eq.) is yet to be discovered, the mathematical usefulness of the equations is rather deep and efficient to understand one of the most basic phenomenon of differential topology in four dimension, namely, the existence of non-equivalent differential smooth structures on the same underlying topological manifold. It has not been efficient enough to solve either the smooth

Poincaré conjecture in dimension 4 or the 11/8-conjecture, but they have been very useful to improve the understanding of the relation between 2^{nd} -homology classes and smooth structures, the symplectic structures on 4-manifolds and to give a construction of a large number of non-equivalent smooth structures on a compact smooth 4-manifold based on the isotopic classes of knots in S^3 [5]. Also, using the *SW*-theory, the Thom conjecture was proved in [9] and some results in [13] were obtained in a much easier way than the one using *YM*-theory. Most of the simplicity coming from the *SW*-theory, as compared with the *YM*-theory, came from the fact that the structural group in *SW*-theory is the abelian U_1 , whereas in *YM*-theory the group is the non-abelian SU_2 .

During the 80's and early 90's, the Yang–Mills Theory was used to define a set of smooth invariants on 4-manifolds known as Donaldson invariants [2]. The Donaldson invariants shed new light on the theory of smooth 4-manifolds, e.g., the existence of a non enumerable set of exotics \mathbb{R}^4 . However, the Donaldson Theory relies on a difficult analysis mostly carried out in the work of Karen Uhlenbeck [19] and also of Clifford Taubes [7]. Late in the 80's, Witten, in [21], showed that the Donaldson invariants could be described as the expectation values of a Topological Quantum Field Theory. The Yang–Mills functional was first described in 1954, by Yang and Mills [22], aiming to give a general framework in which the most basic nature's interactions would fit in. The configuration space of the Yang–Mills theory is the space of connections associated to a principal G -bundle (G =structural group) P over a 4-manifold X . The Yang–Mills functional is invariant by a conformal diffeomorphism of X and by the Gauge Group, the group of automorphism of P . The Euler-Lagrange equation of the Yang–Mills functional is known as Yang–Mills equation and written as $d^*F_A = 0$ (2^{nd} -order PDE). Whenever the theory is on a principal SU_2 -bundle, the stable critical points of the Yang–Mills functional are named *Instantons* and satisfies the anti-self dual equations (*asd*) $F_A^+ = 0$, a 1^{st} -order PDE. Thanks to the conformal invariance of the *YM*-functional, any instanton in \mathbb{R}^4 can be lifted to a solution on S^4 . Once P is fixed, the set of instantons in S^4 is a smooth manifold of dimension $d = 8k - 3$, where $k = c_2(P)$ is the 2^{nd} -Chern class of P . The *asd*-equation has some analogy with the Cauchy-Riemann equations for the Harmonic equation.

As mentioned before, the Seiberg–Witten equations came out of a duality principle and not of a variational one. However, in [20] Witten introduced a functional without making any use of it in order to derive the equations or understand their analytical properties. It turns out that the stable critical points of this functional are the solutions of the *SW*-monopole equation; it is an open question to find on a smooth manifold a sufficient condition to the existence of a *SW*-monopole.

An outstanding difference between the Yang–Mills and *SW*-functional is the fact that the *SW*-functional is not invariant by conformal diffeomorphism of the 4-manifold and the only solution in R^4 is the trivial one $(0, 0)$, as proved in 5.1.

The *SW*-equations and the *YM*-equation become elliptic by considering them modulo the gauge invariance. In fact, the analytical properties depend on a special slice of the action defined in 3.15.

The variational setting of the Seiberg–Witten equation were explored in [8] and [4]. The main purpose of these notes is to introduce and describe the Variational Principle and some of its analytical consequences to the *SW*-equations. A interesting feature for the variational setting would be an interpretation, in terms of the geometry of the configuration space, to the *SW*-invariants. The article is organised as follows;

- section 1 – Introduction
- section 2 – Background
- section 3 – Variational Principle
- section 4 – Main Estimate
- section 5 – \mathcal{H} -Condition and Palais-Smale Condition
- section 6 – Homotopy Type of the Configuration Space
- section 7 – Dirichlet and Neumann Problems associated to the *SW*-equation.

It is a great pleasure to contribute to the volume in honour of the 70th birthday of Professor Djairo Figueiredo, whose contribution to the Brazilian mathematical community has been outstanding.

2. Background

2.1. Spin^c Structure

A *Spin^c* structure in dimension 4 is related to a lift of $Spin_4^c \simeq (SU_2 \times SU_2) \times_{\mathbb{Z}_2} U_1$ to $Spin_4 \times U_1 \simeq SU_2 \times SU_2 \times U_1$.

Let X be a smooth, compact 4-manifold with boundary unless the boundaryless condition is mentioned. The space of *Spin^c* structures on X is identified with

$$Spin^c(X) = \{\alpha = \beta + \gamma \in H^2(X, \mathbb{Z}) \oplus H^1(X, \mathbb{Z}_2) \mid w_2(X) = \beta \text{ mod } 2\}.$$

For each $\alpha \in Spin^c(X)$, there are the representations $\rho_\alpha : SO_4 \rightarrow SU_2 \times SU_2$, induced by the irreductable $\mathbb{C}l_4$ -representation, and $det(\alpha) : SO_4 \rightarrow \mathbb{C}$. These representations allow the construction of a pair of associated vector bundles $(\mathcal{S}_\alpha^+, \mathcal{L}_\alpha)$ over X as follows [10]: let P_{SO_4} be the frame bundle of X ; so

- $\mathcal{S}_\alpha = P_{SO_4} \times_{\rho_\alpha} V = \mathcal{S}_\alpha^+ \oplus \mathcal{S}_\alpha^-$.
 $V \simeq \mathbb{C}^2 \oplus \mathbb{C}^2$ is the irreductable $\mathbb{C}l_4$ -module split by the volume form of the Clifford Algebra $\mathbb{C}l_4 \simeq M_4(\mathbb{C})$. The bundles \mathcal{S}_α^\pm are the positive and the negative complex spinors bundle whose fibers are isomorphic to \mathbb{C}^2 .

- $\mathcal{L}_\alpha = P_{SO_4} \times_{det(\alpha)} \mathbb{C}$.

It is called the *determinant line bundle* associated to the *Spin^c*-structure α ($c_1(\mathcal{L}_\alpha) = \alpha$).

Thus, for each $\alpha \in Spin^c(X)$ we associate a pair of bundles

$$\alpha \in Spin^c(X) \rightsquigarrow (\mathcal{L}_\alpha, \mathcal{S}_\alpha^+).$$

From now on, we consider fixed a riemannian metric g on X and an hermitian structure h on \mathcal{S}_α .

Let P_α be the U_1 -principal bundle over X obtained as the frame bundle of \mathcal{L}_α ($c_1(P_\alpha) = \alpha$). Also, we consider the adjoint bundles

$$Ad(U_1) = P_{U_1} \times_{Ad} U_1 \quad ad(\mathfrak{u}_1) = P_{U_1} \times_{ad} \mathfrak{u}_1,$$

where $Ad(U_1)$ is a bundle with fiber U_1 , and $ad(\mathfrak{u}_1)$ is a vector bundle with fiber isomorphic to the Lie Algebra \mathfrak{u}_1 .

Let \mathcal{A}_α be (formally) the space of connections (covariant derivative) on \mathcal{L}_α , $\Gamma(\mathcal{S}_\alpha^+)$ the space of sections of \mathcal{S}_α^+ and $\mathcal{G}_\alpha = \Gamma(Ad(U_1))$ the gauge group acting on $\mathcal{A}_\alpha \times \Gamma(\mathcal{S}_\alpha^+)$ as follows:

$$g.(A, \phi) = (A + g^{-1}dg, g^{-1}\phi). \tag{2.1}$$

\mathcal{A}_α is an affine space whose vector space structure, after fixing an origin, is isomorphic to the space $\Omega^1(ad(\mathfrak{u}_1))$ of $ad(\mathfrak{u}_1)$ -valued 1-forms. Once a connection $\nabla^0 \in \mathcal{A}_\alpha$ is fixed, a bijection $\mathcal{A}_\alpha \leftrightarrow \Omega^1(ad(\mathfrak{u}_1))$ is made explicit by $\nabla^A \leftrightarrow A$, where $\nabla^A = \nabla^0 + A$. $\mathcal{G}_\alpha = Map(X, U_1)$, since $Ad(U_1) \simeq X \times U_1$. The curvature of a 1-connection form $A \in \Omega^1(ad(\mathfrak{u}_1))$ is the 2-form $F_A = dA \in \Omega^2(ad(\mathfrak{u}_1))$.

2.2. Seiberg–Witten Monopole Equation

Since we are in dimension 4, the vector bundle $\Omega^2(ad(\mathfrak{u}_1))$ splits as

$$\Omega^2_+(ad(\mathfrak{u}_1)) \oplus \Omega^2_-(ad(\mathfrak{u}_1)), \tag{2.2}$$

here (+) is the self-dual component and (-) the anti-self-dual.

The 1st-order *SW*-monopole equations are defined over the configuration space $\mathcal{C}_\alpha = \mathcal{A}_\alpha \times \Gamma(\mathcal{S}_\alpha^+)$ as

$$\begin{cases} D_A^+(\phi) = 0, \\ F_A^+ = \sigma(\phi), \end{cases} \tag{2.3}$$

where

- D_A^+ is the *Spinc*-Dirac operator defined on $\Gamma(\mathcal{S}_\alpha^+)$,
- The quadratic form $\sigma : \Gamma(\mathcal{S}_\alpha^+) \rightarrow End^0(\mathcal{S}_\alpha^+)$ given by

$$\sigma(\phi) = \phi \otimes \phi^* - \frac{|\phi|^2}{2} \cdot I \tag{2.4}$$

performs the coupling of the *ASD*-equation with the *Dirac*^c operator. Locally, for $\phi = (\phi_1, \phi_2)$, the quadratic form takes the value

$$\sigma(\phi) = \begin{pmatrix} \frac{|\phi_1|^2 - |\phi_2|^2}{2} & \phi_1 \cdot \bar{\phi}_2 \\ \phi_2 \cdot \bar{\phi}_1 & \frac{|\phi_2|^2 - |\phi_1|^2}{2} \end{pmatrix}.$$

The set of solutions of (2.3), known as *SW*-monopoles space, is the space $\mathcal{F}^{-1}(0)$, where $\mathcal{F}_\alpha : \mathcal{C}_\alpha \rightarrow \Omega^2_+(X) \oplus \Gamma(\mathcal{S}_\alpha^-)$ is a map defined by

$$\mathcal{F}_\alpha(A, \phi) = (F_A^+ - \sigma(\phi), D_A^+(\phi)).$$

The *SW*_α-equations are \mathcal{G}_α -invariant and the map \mathcal{F} is a Fredholm map up to the gauge equivalence.

Definition 2.1. A SW_α -monopole is a solution (A, ϕ) of the SW_α -monopole equation such that $\phi \neq 0$. Solutions of type $(A, 0)$ come from an anti-self-dual connection A .

3. Variational Principle

3.1. Sobolev Spaces

As a vector bundle E over (X, g) is endowed with a metric and a covariant derivative ∇ , we define the Sobolev norm of a section $\phi \in \Omega^0(E)$ as

$$\|\phi\|_{L^{k,p}} = \sum_{|i|=0}^k \left(\int_X |\nabla^i \phi|^p \right)^{\frac{1}{p}}.$$

In this way, the $L^{k,p}$ -Sobolev Spaces of sections of E are defined as

$$L^{k,p}(E) = \{\phi \in \Omega^0(E) \mid \|\phi\|_{L^{k,p}} < \infty\}.$$

In our context, in which we fixed a connection ∇^0 on \mathcal{L}_α , a metric g on X and an hermitian structure on \mathcal{S}_α , the Sobolev Spaces on which the basic setting is made are the following;

- $\mathcal{A}_\alpha = L^{1,2}(\Omega^1(ad(u_1)))$;
- $\Gamma(\mathcal{S}_\alpha^+) = L^{1,2}(\Omega^0(X, \mathcal{S}_\alpha^+))$;
- $\mathcal{C}_\alpha = \mathcal{A}_\alpha \times \Gamma(\mathcal{S}_\alpha^+)$;
- $\mathcal{G}_\alpha = L^{2,2}(X, U_1) = L^{2,2}(Map(X, U_1))$.

(\mathcal{G}_α is an ∞ -dimensional Lie Group which Lie algebra is $\mathfrak{g} = L^{1,2}(X, u_1)$).

The Dirichlet (\mathcal{D}) and Neumann (\mathcal{N}) problems require their own configuration spaces $\mathcal{C}_\alpha^{\mathcal{D}}$ and $\mathcal{C}_\alpha^{\mathcal{N}}$, respectively. From now on, both the configuration spaces will be denoted by \mathcal{C}_α by ignoring the superscripts, unless they are needed.

The most basic analytical results are the *Gauge Fixing Lemma* (Uhlenbeck [19]) and the estimate 3.1, both extended by Marini [12] to manifolds with boundary; it gives a clue to define a suitable slice of the \mathcal{G}_α -action.

Lemma 3.1 (Gauge Fixing Lemma). *Every connection $\hat{A} \in \mathcal{A}_\alpha$ is gauge equivalent, by a gauge transformation $g \in \mathcal{G}_\alpha$ named Coulomb (\mathcal{C}) gauge, to a connection $A \in \mathcal{A}_\alpha$ satisfying*

1. $d_\tau^{*f} A_\tau = 0$ on ∂X ,
2. $d^* A = 0$ on X .
3. *In the \mathcal{N} -problem, the connection A satisfies $A_\nu = 0$ ($\nu \perp \partial X$).*

Corollary 3.2. *Under the hypothesis of 3.1, there exists a constant $K > 0$ such that the connection A , gauge equivalent to \hat{A} by the Coulomb gauge, satisfies the estimate*

$$\|A\|_{L^{1,p}} \leq K \cdot \|F_A\|_{L^p}. \tag{3.1}$$

Notation: $*_f$ is the Hodge operator in the flat metric and the index τ denotes tangential components.

3.2. Variational Formulation

The most natural functional to be considered is

$$SW(A, \phi) = \frac{1}{2} \int_X \{ |F_A^+ - \sigma(\phi)|^2 + |D_A^+(\phi)|^2 \} dv_g. \tag{3.2}$$

Clearly, the SW_α -monopoles are the stable critical points. The next set of identities are applied to expand the functional 3.2.

Proposition 3.3. *For each $\alpha \in Spin^c(X)$, let \mathcal{L}_α be the determinant line bundle associated to α and $(A, \phi) \in \mathcal{C}_\alpha$. Also, assume that k_g =scalar curvature of (X, g) . Then,*

1. $\langle F_A^+, \sigma(\phi) \rangle = \frac{1}{2} \langle F_A^+ \cdot \phi, \phi \rangle.$
2. $\langle \sigma(\phi), \sigma(\phi) \rangle = \frac{1}{4} |\phi|^4.$
3. *Weitzenböck formula*

$$D^2\phi = \nabla^* \nabla \phi + \frac{k_g}{4} \phi + \frac{F_A}{2} \cdot \phi.$$

4. $\sigma(\phi)\phi = \frac{|\phi|^2}{2} \phi.$
5. *The intersection form of X $Q_X : H^2(X, \mathbb{R}) \times H^2(X, \mathbb{R}) \rightarrow \mathbb{R}$ is given by*

$$Q(\omega, \eta) = \int_X \omega \wedge \eta, \quad \alpha^2 = Q(\alpha, \alpha).$$

6. $\int_X |F_A^+|^2 dv_g = \int_X \frac{1}{2} |F_A|^2 dv_g + 2\pi^2 \alpha^2.$

As a consequence, a new functional turns up into the scenario;

Definition 3.4. *For each $\alpha \in Spin^c(X)$, the Seiberg–Witten Functional is the functional $SW_\alpha : \mathcal{C}_\alpha \rightarrow \mathbb{R}$ given by*

$$SW_\alpha(A, \phi) = \int_X \{ \frac{1}{4} |F_A|^2 + |\nabla^A \phi|^2 + \frac{1}{8} |\phi|^4 + \frac{1}{4} k_g |\phi|^2 \} dv_g + \pi^2 \alpha^2, \tag{3.3}$$

where k_g is the scalar curvature of (X, g) .

Remark 3.5.

1. Since X is compact and $\|\phi\|_{L^4} < \|\phi\|_{L^{1,2}}$, the functional is well defined on \mathcal{C}_α .
2. The SW_α -functional (3.3) being Gauge invariant induces a functional $SW_\alpha : \mathcal{A}_\alpha \times_{\mathcal{G}_\alpha} \Gamma(S_\alpha^+) \rightarrow \mathbb{R}.$
3. The SW_α -functional is bounded below by 0, and it is equal to 0 if and only if either there exists a SW_α -monopole or a anti-self-dual U_1 -connection.

It is an open question to find a sufficient condition to prove that there exists a SW_α -monopole on a 4-manifold X . If X is symplectic, Taubes [16] proved that whenever α is the canonical class then there is a SW_α -monopole. As a consequence of the main estimate 4.1, there is a non-existence result for SW_α -monopoles on manifolds whose scalar curvature is non-negative. A necessary condition for the existence of a SW_α -monopole is the following estimate;

Proposition 3.6. *Let $\alpha \in Spin^c(X)$ and (A, ϕ) be a \mathcal{SW}_α -monopole. Then*

$$\alpha^2 \leq \frac{2}{\pi^2} v_X \cdot (k_{g,X}^-)^4. \tag{3.4}$$

Proof. We have

$$\mathcal{SW}_\alpha(A, \phi) - \int_X k_g |\phi|^2 = \frac{1}{4} \|F_A\|_{L^2}^2 + \|\nabla^A \phi\|_{L^2}^2 + \frac{1}{8} \|\phi\|_{L^4}^4,$$

therefore, taking $k_{g,X}^- = \min_{x \in X} k_g(x)$,

$$\mathcal{SW}_\alpha(A, \phi) + (-k_{g,X}^-) \|\phi\|_{L^2}^2 \geq \frac{1}{4} \|F_A\|_{L^2}^2 + \|\nabla^A \phi\|_{L^2}^2 + \frac{1}{8} \|\phi\|_{L^4}^4,$$

and,

$$\|\phi\|_{L^4}^4 \leq 8\mathcal{SW}_\alpha(A, \phi) + 8(k_{g,X}^-)^2 \|\phi\|_{L^2}^2,$$

where $k_{X,g}^- = \sqrt{\max\{0, -k_{X,g}^-\}}$. It follows from inequality (7.1) that

$$\|\phi\|_{L^2}^4 \leq 8v_X \mathcal{SW}_\alpha(A, \phi) + 8v_X \cdot (k_{g,X}^-)^2 \|\phi\|_{L^2}^2.$$

So,

$$\|\phi\|_{L^2}^4 - 8v_X \cdot (k_{g,X}^-)^2 \|\phi\|_{L^2}^2 - 8v_X \mathcal{SW}_\alpha(A, \phi) \leq 0. \tag{3.5}$$

Let us consider the quadratic function $f : \mathbb{R} \rightarrow \mathbb{R}$

$$f(x) = x^2 - 8v_X \cdot (k_{g,X}^-)^2 x - 8v_X \mathcal{SW}_\alpha(A, \phi).$$

If the inequality $f(x) \leq 0$ is not satisfied by any $x \in \mathbb{R}$, then we would have $\phi = 0$. The discriminant of f is

$$\Delta = 32v_X \left(2v_X \cdot (k_{g,X}^-)^4_{g,X} + \mathcal{SW}_\alpha(A, \phi) \right).$$

The inequality (3.5) admits solution if and only if $\Delta \geq 0$, since $f''(x) > 0$ and $\min_{x \in \mathbb{R}} f(x) = -\frac{\Delta}{4}$. Therefore,

$$\mathcal{SW}_\alpha(A, \phi) \geq -2v_X \cdot (k_{g,X}^-)^4.$$

Since $\mathcal{SW}_\alpha(A, \phi) = -\pi^2 \alpha^2$, the lower upper bound of the \mathcal{SW}_α -functional is

$$\mathcal{SW}_\alpha(A, \phi) \geq \max\{-\pi^2 \alpha^2, -2v_X \cdot (k_{g,X}^-)^4\}.$$

In this way, if (A, ϕ) is a \mathcal{SW}_α -monopole satisfying the 1st-order \mathcal{SW}_α -equation then $\mathcal{SW}_\alpha(A, \phi) = -\pi^2 \alpha^2$, where

$$\alpha^2 \leq \frac{2}{\pi^2} v_X \cdot (k_{g,X}^-)^4.$$

The L^2 -norm of a spinor field turns out to be bounded, as shown in the identity below;

$$4v_X \cdot (k_{g,X}^-)^2 - 2\sqrt{4v_X \left[2v_X (k_{g,X}^-)^4 + \mathcal{SW}_\alpha(A, \phi) \right]} \leq \|\phi\|_{L^2}^2 \tag{3.6}$$

$$\leq 4v_X \cdot (k_{g,X}^-)^2 + 2\sqrt{4v_X \left[2v_X \cdot (k_{g,X}^-)^4 + \mathcal{SW}_\alpha(A, \phi) \right]} \tag{3.7} \quad \square$$

The Euler-Lagrange equations of the \mathcal{SW}_α -functional (3.3) are

$$\Delta_A \phi + \frac{|\phi|^2}{4} \phi + \frac{k_g}{4} \phi = 0, \tag{3.8}$$

$$d^* F_A + 4\Phi^*(\nabla^A \phi) = 0, \tag{3.9}$$

where $\Phi : \Omega^1(\mathbf{u}_1) \rightarrow \Omega^1(\mathcal{S}_\alpha^+)$. The dual operator $\Phi^* : \Omega^1(\mathcal{S}_\alpha^+) \rightarrow \Omega^1(\mathbf{u}_1)$ is locally, in a orthonormal basis $\{\eta^i\}_{1 \leq i \leq 4}$ of T^*X , written as

$$\Phi^*(\nabla^A \phi) = \sum_{i=1}^4 \langle \nabla_i^A \phi, \phi \rangle \eta^i, \quad \text{where} \quad \nabla_i^A = \nabla_{X_i}^A \quad (\eta_i(X_j) = \delta_{ij}). \tag{3.10}$$

The equations above are referred as the \mathcal{SW}_α -equations.

Remark 3.7. The \mathcal{G}_α -action on \mathcal{C}_α has the following properties;

1. the \mathcal{SW}_α -functional is \mathcal{G}_α -invariant.
2. the \mathcal{G}_α -action on \mathcal{C}_α induces on $T\mathcal{C}_\alpha$ a \mathcal{G}_α -action as follows:
let $(\Lambda, V) \in T_{(A,\phi)}\mathcal{C}_\alpha$ and $g \in \mathcal{G}_\alpha$, then

$$g \cdot (\Lambda, V) = (\Lambda, g^{-1}V) \in T_{g \cdot (A,\phi)}\mathcal{C}_\alpha.$$

Consequently, $d(\mathcal{SW}_\alpha)_{g \cdot (A,\phi)}(g \cdot (\Lambda, V)) = d(\mathcal{SW}_\alpha)_{(A,\phi)}(\Lambda, V)$.

The tangent bundle $T\mathcal{C}_\alpha$ decomposes as

$$T\mathcal{C}_\alpha = \Omega^1(ad(\mathbf{u}_1)) \oplus \Gamma(\mathcal{S}_\alpha^+).$$

In this way, the 1-form $d\mathcal{SW}_\alpha \in \Omega^1(\mathcal{C}_\alpha)$ can be decomposed as

$d\mathcal{SW}_\alpha = d_1\mathcal{SW}_\alpha + d_2\mathcal{SW}_\alpha$, where

$$d_1(\mathcal{SW}_\alpha)_{(A,\phi)} : \Omega^1(ad(\mathbf{u}_1)) \rightarrow \mathbb{R}, \quad d_1(\mathcal{SW}_\alpha)_{(A,\phi)} \cdot \Lambda = d(\mathcal{SW}_\alpha)_{(A,\phi)} \cdot (\Lambda, 0)$$

$$d_2(\mathcal{SW}_\alpha)_{(A,\phi)} : \Gamma(\mathcal{S}_\alpha^+) \rightarrow \mathbb{R}, \quad d_2(\mathcal{SW}_\alpha)_{(A,\phi)} \cdot V = d(\mathcal{SW}_\alpha)_{(A,\phi)} \cdot (0, V).$$

By performing the computations, we get

1. for every $\Lambda \in \mathcal{A}_\alpha$,

$$d_1(\mathcal{SW}_\alpha)_{(A,\phi)} \cdot \Lambda = \frac{1}{4} \int_X Re\{ \langle F_A, d_A \Lambda \rangle + 4 \langle \nabla^A(\phi), \Phi(\Lambda) \rangle \} dx, \tag{3.11}$$

where $\Phi : \Omega^1(\mathbf{u}_1) \rightarrow \Omega^1(\mathcal{S}_\alpha^+)$ is the linear operator $\Phi(\Lambda) = \Lambda(\phi)$, whose dual is defined in 3.10,

2. for every $V \in \Gamma(\mathcal{S}_\alpha^+)$,

$$d_2(\mathcal{SW}_\alpha)_{(A,\phi)} \cdot V = \int_X Re\{ \langle \nabla^A \phi, \nabla^A V \rangle + \langle \frac{|\phi|^2 + k_g}{4} \phi, V \rangle \} dx. \tag{3.12}$$

Therefore, by taking $supp(\Lambda) \subset int(X)$ and $supp(V) \subset int(X)$, we restrict to the interior of X , and so, the gradient of the \mathcal{SW}_α -functional at $(A, \phi) \in \mathcal{C}_\alpha$ is

$$grad(\mathcal{SW}_\alpha)(A, \phi) = (d_A^* F_A + 4\Phi^*(\nabla^A \phi), \Delta_A \phi + \frac{|\phi|^2 + k_g}{4} \phi). \tag{3.13}$$

It follows from the \mathcal{G}_α -action on TC_α that

$$\text{grad}(\mathcal{SW}_\alpha)(g.(A, \phi)) = \left(d_A^* F_A + 4\Phi^*(\nabla^A \phi), g^{-1} . (\Delta_A \phi + \frac{|\phi|^2 + k_g}{4} \phi) \right). \tag{3.14}$$

3.3. Coercivity of the \mathcal{SW}_α -Functional

An important analytical aspect of the \mathcal{SW}_α -functional is the Coercivity Lemma proved in [8].

Lemma 3.8 (Coercivity). *For each $(A, \phi) \in \mathcal{C}_\alpha$, there exists $g \in \mathcal{G}_\alpha$ and a constant $K_{\mathfrak{e}}^{(A, \phi)} > 0$, where $K_{\mathfrak{e}}^{(A, \phi)}$ depends on (X, g) and $\mathcal{SW}_\alpha(A, \phi)$, such that*

$$\| g.(A, \phi) \|_{L^{1,2}} < K_{\mathfrak{e}}^{(A, \phi)}.$$

Proof. Lemma 2.3 in [8]. The gauge transform is the Coulomb one given in the Gauge Fixing Lemma 3.1. □

Considering the gauge invariance of the \mathcal{SW}_α -theory, and the fact that the gauge group \mathcal{G}_α is a infinite dimensional Lie Group, we can't hope to handle any analytical question in general, we need to work on a slice for the action. So forth, we restrict the problem to the space, named Coulomb subspace,

$$\mathcal{C}_\alpha^{\mathfrak{e}} = \{ (A, \phi) \in \mathcal{C}_\alpha; \| (A, \phi) \|_{L^{1,2}} < K_{\mathfrak{e}}^{(A, \phi)} \}, \tag{3.15}$$

4. Main Estimate

In order to pursue the strong $L^{1,2}$ -convergence for the sequence $\{(A_n, \phi_n)\}_{n \in \mathbb{Z}}$, given by condition 5.1, next we obtain an upper bound for $\| \phi \|_{L^\infty}$, whenever (A, ϕ) is a weak solution. Due to its fundamental importance, it is named the *Main Estimate*.

Lemma 4.1. *Let (A, ϕ) be a solution of either \mathcal{D} or \mathcal{N} in 7.1. Then:*

1. *If $\sigma = 0$, then there exists a constant $k_{X,g}$, depending on the Riemannian metric on X , such that*

$$\| \phi \|_\infty < k_{X,g}, \quad k_{X,g} = \sqrt{\max_{x \in X} \{0, -k_g(x)\}}. \tag{4.1}$$

2. *If $\sigma \neq 0$, then there exist constants $c_1 = c_1(X, g)$ and $c_2 = c_2(X, g)$ such that*

$$\| \phi \|_{L^p} < c_1 + c_2 \| \sigma \|_{L^{3p}}^3. \tag{4.2}$$

In particular, if $\sigma \in L^\infty$ then $\phi \in L^\infty$

Proof. Fix $r \in \mathbb{R}$ and suppose that there is a ball $B_{r-1}(x_0)$, around the point $x_0 \in X$, such that

$$| \phi(x) | > r, \quad \forall x \in B_{r-1}(x_0).$$

Define

$$\eta = \begin{cases} \left(1 - \frac{r}{|\phi|}\right) \phi, & \text{if } x \in B_{r-1}(x_0), \\ 0, & \text{if } x \in X - B_{r-1}(x_0). \end{cases}$$

So,

$$\begin{aligned} |\eta| &\leq |\phi| & (4.3) \\ \nabla\eta &= r \frac{\langle \phi, \nabla\phi \rangle}{|\phi|^3} \phi + \left(1 - \frac{r}{|\phi|}\right) \nabla\phi \\ \Rightarrow |\nabla\eta|^2 &= r^2 \frac{\langle \phi, \nabla\phi \rangle^2}{|\phi|^4} + 2r\left(1 - \frac{r}{|\phi|}\right) \frac{\langle \phi, \nabla\phi \rangle^2}{|\phi|^3} + \left(1 - \frac{r}{|\phi|}\right)^2 |\nabla\phi|^2 \\ &\Rightarrow |\nabla\eta|^2 < r^2 \frac{|\nabla\phi|^2}{|\phi|^2} + 2r\left(1 - \frac{r}{|\phi|}\right) \frac{|\nabla\phi|^2}{|\phi|} + \left(1 - \frac{r}{|\phi|}\right)^2 |\nabla\phi|^2. \end{aligned}$$

Since $r < |\phi|$,

$$|\nabla\eta|^2 < 4 |\nabla\phi|^2. \tag{4.4}$$

Hence, by 4.3 and 4.4, $\eta \in L^{1,2}$.

The directional derivative of \mathcal{SW}_α in direction η is given by

$$d(\mathcal{SW}_\alpha)_{(A,\phi)}(0, \eta) = \int_X [\langle \nabla^A \phi, \nabla^A \eta \rangle + \frac{|\phi|^2 + k_g}{4} |\phi| (|\phi| - r)].$$

By 3.12),

$$\int_X [\langle \nabla^A \phi, \nabla^A \eta \rangle + \frac{|\phi|^2 + k_g}{4} |\phi| (|\phi| - r)] = \int_X \langle \sigma, \left(1 - \frac{r}{|\phi|}\right) \phi \rangle.$$

However,

$$\int_X \langle \nabla^A \phi, \nabla^A \eta \rangle = \int_X \left[r \frac{\langle \phi, \nabla^A \phi \rangle^2}{|\phi|^3} + \left(1 - \frac{r}{|\phi|}\right) |\nabla\phi|^2 \right] > 0.$$

So,

$$\int_X \frac{|\phi|^2 + k_g}{4} |\phi| (|\phi| - r) < \int_X \langle \sigma, \left(1 - \frac{r}{|\phi|}\right) \phi \rangle < \int_X |\sigma| (|\phi| - r).$$

Hence,

$$\int_X (|\phi| - r) \left(\frac{|\phi|^2 + k_g}{4} |\phi| - |\sigma| \right) < 0.$$

Since $r < |\phi(x)|$, whenever $x \in B_{r-1}(x_0)$, it follows that

$$(|\phi|^2 + k_g) |\phi| < 4 |\sigma|, \quad \text{almost everywhere in } B_{r-1}(x_0). \tag{4.5}$$

There are two cases to be analysed independently.

1. $\sigma = 0$.

In this case, we get

$$(|\phi|^2 + k_g) |\phi| < 0, \quad \text{almost everywhere.} \tag{4.6}$$

The scalar curvature plays a central role here: if $k_g \geq 0$ then $\phi = 0$; otherwise,

$$|\phi| \leq \max\{0, (-k_g)^{1/2}\}.$$

Since X is compact, we let $k_{X,g} = \sqrt{\max_{x \in X} \{0, -k_g(x)\}}$, and so,

$$\|\phi\|_\infty < k_{X,g}.$$

2. Let $\sigma \neq 0$.

The inequality 4.5 implies that

$$|\phi|^3 + k_g |\phi| - 4 |\sigma| < 0 \quad \text{a.e.}$$

Consider the polynomial

$$Q_{\sigma(x)}(w) = w^3 + k_g w - 4 |\sigma(x)|.$$

A estimate for $|\phi|$ is obtained by estimating the largest real number w satisfying $Q_{\sigma(x)}(w) < 0$. $Q_{\sigma(x)}$ being monic implies that $\lim_{w \rightarrow \infty} Q_{\sigma(x)}(w) = +\infty$. So, either $Q_{\sigma(x)} > 0$, whenever $w > 0$, or there exist a root $\rho \in (0, \infty)$. The first case would imply that

$$Q_{\sigma(x)}(|\phi(x)|) > 0, \quad \text{a.e.,}$$

contradicting 4.5. By the same argument, there exists a root $\rho \in (0, \infty)$ such that $Q_{\sigma(x)}(w)$ changes its sign in a neighborhood of ρ . Let ρ be the largest root in $(0, \infty)$ with this property. There exist constants $c_1 = c_1(X, g)$ and c_2 such that

$$|\rho| < c_1 + c_2 |\sigma(x)|^3.$$

Consequently,

$$|\phi(x)| < c_1 + c_2 |\sigma(x)|^3, \quad \text{a.e. in } B_{r-1}(x_0) \tag{4.7}$$

and

$$\|\phi\|_{L^p} < C_1 + C_2 \|\sigma\|_{L^{3p}}^3, \quad \text{restricted to } B_{r-1}(x_0) \tag{4.8}$$

where C_1, C_2 are constants depending on $\text{vol}(B_{r-1}(x_0))$. The inequality 4.8 can be extended over X by using a C^∞ partition of unity. Moreover, if $\sigma \in L^\infty$, then

$$\|\phi\|_\infty < C_1 + C_2 \|\sigma\|_\infty^3, \tag{4.9}$$

where C_1, C_2 are constants depending on $\text{vol}(X)$. □

5. \mathcal{H} -Condition and Palais-Smale Condition

In the variational formulation, the problems \mathcal{D} and \mathcal{N} (7.1) are written as

$$(\mathcal{D}) = \begin{cases} \text{grad}(\mathcal{SW}_\alpha)(A, \phi) = (\Theta, \sigma), \\ (A, \phi) |_{\partial X} \stackrel{\text{gauge}}{\sim} (A_0, \phi_0), \end{cases} \quad (\mathcal{N}) = \begin{cases} \text{grad}(\mathcal{SW}_\alpha)(A, \phi) = (\Theta, \sigma), \\ i^*(F_A) = 0, \nabla_n^A \phi = 0. \end{cases} \tag{5.1}$$

The equations in 5.1 may not admit a solution for any pair $(\Theta, \sigma) \in \Omega^1(\text{ad}(\mathbf{u}_1)) \oplus \Gamma(\mathcal{S}_\alpha^+)$. In finite dimension, if we consider a function $f : X \rightarrow \mathbb{R}$, the analogous question would be to find a point $p \in X$ such that, for a fixed vector u , $\text{grad}(f)(p) = u$. This question is more subtle if f is invariant under a Lie

group action on X . Therefore, we need the hypothesis below on the pair $(\Theta, \sigma) \in \Omega^1(ad(\mathbf{u}_1)) \oplus \Gamma(\mathcal{S}_\alpha^+)$;

Condition 5.1 (\mathcal{H}). *Let $(\Theta, \sigma) \in L^{1,2}(\Omega^1(ad(\mathbf{u}_1))) \oplus (L^{1,2}(\Gamma(\mathcal{S}_\alpha^+)) \cap L^\infty(\Gamma(\mathcal{S}_\alpha^+)))$ be a pair such that there exists a sequence $\{(A_n, \phi_n)\}_{n \in \mathbb{Z}} \subset \mathcal{C}_\alpha^{\mathcal{E}}$ (3.15) with the following properties;*

1. $\{(A_n, \phi_n)\}_{n \in \mathbb{Z}} \subset L^{1,2}(\mathcal{A}_\alpha) \times (L^{1,2}(\Gamma(\mathcal{S}_\alpha^+)) \cup L^\infty(\Gamma(\mathcal{S}_\alpha^+)))$ and there exists a constant $c_\infty > 0$ such that, for all $n \in \mathbb{Z}$, $\|\phi_n\|_\infty < c_\infty$.
2. there exists $c \in \mathbb{R}$ such that, for all $n \in \mathbb{Z}$, $\mathcal{S}W_\alpha(A_n, \phi_n) < c$,
3. the sequence $\{d(\mathcal{S}W_\alpha)_{(A_n, \phi_n)}\}_{n \in \mathbb{Z}} \subset (L^{1,2}(\Omega^1(ad(\mathbf{u}_1))) \oplus L^{1,2}(\Gamma(\mathcal{S}_\alpha^+)))^*$, of linear functionals, converges weakly to

$$L_\Theta + L_\sigma : TC_\alpha \rightarrow \mathbb{R},$$

where

$$L_\Theta(\Lambda) = \int_X \langle \Theta, \Lambda \rangle, \quad L_\sigma(V) = \int_X \langle \sigma, V \rangle.$$

As a consequence of 3.8, the sequence $\{(A_n, \phi_n)\}_{n \in \mathbb{Z}}$ given by the \mathcal{H} -condition has the following properties;

1. It converges to a pair (A, ϕ) weakly in \mathcal{C}_α .
2. It converges to a pair (A, ϕ) weakly in $L^4(\mathcal{A}_\alpha \times \Gamma(\mathcal{S}_\alpha^+))$.
3. It converges to a pair (A, ϕ) strongly in $L^p(\mathcal{A}_\alpha \times \Gamma(\mathcal{S}_\alpha^+))$, for every $p < 4$.
4. The limit $(A, \phi) \in L^2(\mathcal{A}_\alpha \times \Gamma(\mathcal{S}_\alpha^+))$, obtained as a limit of the sequence $\{(A_n, \phi_n)\}_{n \in \mathbb{Z}}$, is a weak solution of 7.1 ([4]).

It turns out that the sequence $\{(A_n, \phi_n)\}_{n \in \mathbb{Z}}$, given by the \mathcal{H} -condition 5.1, converges strongly. The proof in [4] uses the main estimate 4.1 and the fact that

$$\lim_{n \rightarrow \infty} \int_X \langle \Phi^*(\nabla^{A_n} \phi_n), A_n - A \rangle = 0.$$

Theorem 5.2. [4] *Let (Θ, σ) be a pair satisfying the \mathcal{H} -condition 5.1. Then, the sequence $\{(A_n, \phi_n)\}_{n \in \mathbb{Z}}$, given by 5.1, converges strongly to $(A, \phi) \in \mathcal{C}_\alpha$.*

Corollary 5.3. [8] *The $\mathcal{S}W_\alpha$ -functional satisfies the Palais-Smale Condition.*

$\mathcal{S}W_\alpha$ -Monopoles in $X = \mathbb{R}^4$

It comes out of the Main Estimate that in \mathbb{R}^4 the only solution, up to gauge equivalence, to the $\mathcal{S}W_\alpha$ -equations is $(0, 0)$. The scalar curvature of \mathbb{R}^4 being $k_g = 0$ implies, by the Main Estimate, that any solution has type $(A, 0)$, where $d^*F_A = 0$. However, by Hodge theory $F_A = 0$, so the only solution, up to gauge equivalence, is $(0, 0)$.

6. Homotopy Type of the Configuration Space

In this section, let's consider X a boundaryless smooth 4-manifold. Considering that the $\mathcal{S}W_\alpha$ -functional satisfies the Palais-Smale condition it is natural to ask

about the existence of non-stable critical points. This is achieved once we know the homotopy type of \mathcal{C}_α . The embedding of the Jacobian Torus

$$i : T^{b_1(X)} = \frac{H^1(X, \mathbb{R})}{H^1(X, \mathbb{Z})} \hookrightarrow \mathcal{A}_\alpha \times_{\mathcal{G}_\alpha} \Gamma(S_\alpha^+), \quad b_1(X) = \dim_{\mathbb{R}} H^1(X, \mathbb{R}),$$

defined in 6.1, and the variational formulation of the \mathcal{SW}_α -equations together give us a interpretation to the topology of $\mathcal{A}_\alpha \times_{\mathcal{G}_\alpha} \Gamma(S_\alpha^+)$.

Proposition 6.1. *Let X be a closed, smooth 4-manifold. The solutions of $d^*F_A = 0$, module the \mathcal{G}_α -action, define the Jacobian Torus*

$$T^{b_1(X)} = \frac{H^1(X, \mathbb{R})}{H^1(X, \mathbb{Z})}, \quad b_1(X) = \dim_{\mathbb{R}} H^1(X, \mathbb{Z}).$$

Proof. Let us recall that $\alpha = \frac{i}{2\pi} \int F_A$. The equation $d^*F_A = 0$ implies that F_A is an harmonic 2-form, and by Hodge theory, it is the only one. Let A and B be solutions and consider $B = A + b$, so,

$$d^*F_B + d^*F_A + d^*db = 0 \quad \Rightarrow \quad db = 0,$$

from where we can associate $B \rightsquigarrow b \in H^1(X, \mathbb{R})$ (and $F_B = F_A$).

If a connection B_1 is gauge equivalent to B_2 , then there exists $g \in \mathcal{G}_\alpha$ such that $B = A + g^{-1}dg$ and $F_B = F_A$. However, the 1-form $g^{-1}dg \in H^1(X, \mathbb{Z})$. Consequently, if b_1, b_2 are the respective elements in $H^1(X, \mathbb{R})$, then $b_2 = b_1$ in $\frac{H^1(X, \mathbb{R})}{H^1(X, \mathbb{Z})}$. □

The relation among the critical set of \mathcal{SW}_α -functional and the homotopy of $\mathcal{A}_\alpha \times_{\mathcal{G}_\alpha} \Gamma(S_\alpha^+)$ is described by the next result.

Theorem 6.2. [3] *Let X be a closed smooth 4-manifold endowed with a riemannian metric g which scalar curvature is k_g .*

1. *If $k_g \geq 0$, then the gradient flow of the \mathcal{SW}_α -functional defines an homotopy equivalence among $\mathcal{A}_\alpha \times_{\mathcal{G}_\alpha} \Gamma(S_\alpha^+)$ and $i(T^{b_1(X)})$.*
2. *If $k_g < 0$, then $\mathcal{A}_\alpha \times_{\mathcal{G}_\alpha} \Gamma(S_\alpha^+)$ has the same homotopy type of $T^{b_1(X)}$.*

$(A, 0)$ is a solution of the Monopole \mathcal{SW}_α -equation (minimum for \mathcal{SW}_α) whenever $F_A^+ = 0$. It is known ([2]) that if $b_2^+ > 1$, then such solutions do not exists for a dense set of the space of metrics on X . Therefore:

1. As a consequence of 3.6, only for a finite number of classes $\alpha \in Spin^c(X)$ there exists a \mathcal{SW}_α -monopole attaining the minimum.
2. If $\alpha \in Spin^c(X)$ is none of the classes considered in the previous item, then

$$\inf_{(A, \phi) \in \mathcal{A}_\alpha \times_{\mathcal{G}_\alpha} \Gamma(S_\alpha^+)} \mathcal{SW}_\alpha(A, \phi) > 0.$$

7. Dirichlet and Neumann Problems associated to the SW_α -Equation

The Dirichlet (\mathcal{D}) and Neumann (\mathcal{N}) boundary value problems associated to the SW_α -equations are the following: Let's consider $(\Theta, \sigma) \in \Omega^1(ad(u_1)) \oplus \Gamma(\mathcal{S}_\alpha^+)$ and (A_0, ϕ_0) defined on the manifold ∂X (A_0 is a connection on $\mathcal{L}_\alpha|_{\partial X}$, ϕ_0 is a section of $\Gamma(\mathcal{S}_\alpha^+|_{\partial X})$). In this way, find $(A, \phi) \in \mathcal{C}_\alpha^\mathcal{D}$ satisfying \mathcal{D} and $(A, \phi) \in \mathcal{C}_\alpha^\mathcal{N}$ satisfying \mathcal{N} , where

$$\mathcal{D} = \begin{cases} d^*F_A + 4\Phi^*(\nabla^A\phi) = \Theta, \\ \Delta_A\phi + \frac{(|\phi|^2+k_g)}{4}\phi = \sigma, \\ (A, \phi)|_{\partial X} \underset{\text{gauge}}{\sim} (A_0, \phi_0), \end{cases} \quad \mathcal{N} = \begin{cases} d^*F_A + 4\Phi^*(\nabla^A\phi) = \Theta, \\ \Delta_A\phi + \frac{(|\phi|^2+k_g)}{4}\phi = \sigma, \\ i^*(F_A) = 0, \nabla_\nu^A\phi = 0, \end{cases} \quad (7.1)$$

where $i^*(F_A) = F_4$, $F_4 = (F_{14}, F_{24}, F_{34}, 0)$ is, locally, the 4th-component (normal to ∂X) of the 2-form of curvature in the local chart (x, U) of X ; $x(U) = \{x = (x_1, x_2, x_3, x_4) \in \mathbb{R}^4; \|x\| < \epsilon, x_4 \geq 0\}$, and $x(U \cap \partial X) \subset \{x \in x(U) \mid x_4 = 0\}$. Let $\{e_1, e_2, e_3, e_4\}$ be the canonical base of \mathbb{R}^4 , so $\nu = -e_4$ is the normal vector field along ∂X .

The existence of a strong solution follows from 5.2. Basically, the regularity follows from the corollary 3.2 and from the Main Estimate 4.1, as proved in [4].

Theorem 7.1. [4] *If the pair $(\Theta, \sigma) \in L^{k,2} \oplus (L^{k,2} \cap L^\infty)$ satisfies the \mathcal{H} -condition 5.1, then the problems \mathcal{D} and \mathcal{N} admit a C^r -regular solution (A, ϕ) , whenever $2 < k$ and $r < k$.*

References

- [1] S.K. Donaldson, *The Seiberg–Witten Equations and 4-Manifold Topology*, Bull. Am. Math. Soc., New Ser. **33**, n°1 (1996), 45–70.
- [2] S.K. Donaldson and P. Kronheimer, *The Geometry of 4-Manifold*, Oxford University Press, 1991.
- [3] Celso M. Doria, *The Homotopy Type of the Seiberg–Witten Configuration Space*, Bull. Soc. Paranaense de Mat. **22**, n° 2, 49–62, 2004.
<http://www.spm.uem.br/spmatematica/index.htm>
- [4] Celso M. Doria, *Boundary Value Problems for the 2nd-order Seiberg–Witten Equations*, Journal of Boundary Value Problems, Hindawi, **1**, 2005.
<http://bvp.hindawi.com>
- [5] R. Fintushel and R. Stern, *Knots, Links and Four Manifolds*, Inventiones Mathematicae **134**, n°2 (1998), 363–400.
- [6] D. Gilbarg and N.S. Trudinger, *Elliptic Partial Differential Equations of Second Order*, 2nd edition, SCSM 224, Springer-Verlag, 1983.
- [7] A. Jaffa and C. Taubes, *Vortices and Monopoles*, Progress in Physics, Birkhäuser, 1980.
- [8] J. Jost, X. Peng and G. Wang, *Variational Aspects of the Seiberg–Witten Functional*, Calculus of Variation **4** (1996) , 205–218.

- [9] P. Kronheimer and T. Mrowka, *The Genus of Embedded Surfaces in the Projective Plane*, Math. Res. Letters **1** (1994), 797–808.
- [10] H.B. Lawson and M.L. Michelson, *Spin Geometry*, Princeton University Press, 1989.
- [11] M.N. Feehan and T.G. Leless, *SO(3) monopoles, level-one Seiberg–Witten moduli spaces, and Witten’s conjecture in low degrees*, Proceedings of the 1999 Georgia Topology Conference (Athens, GA). Topology Appl. **124** (2002), no. 2, 221–326.
- [12] A. Marini, *Dirichlet and Neumann Boundary Value Problems for Yang–Mills Connections*, Commuc. on Pure and Applied Math, **XLV** (1992), 1015–1050.
- [13] J. Morgan, *The Seiberg–Witten Equations and Applications to the Topology of Smooth Four-Manifolds*, Math. Notes **44**, Princeton Press.
- [14] R.S. Palais, *Foundations of Global Non-Linear Analysis*, Benjamin, inc, 1968.
- [15] N. Seiberg and E. Witten, *Electric-Magnetic Duality, Monopole Condensation, and Confinement in $N = 2$ SuperSymmetric Yang–Mills Theory*, Nuclear Phys. **B426** (1994).
- [16] C. Taubes, *GR = SW: counting curves and connections*, J. Differential Geom. **52** (1999), no. 3, 453–609.
- [17] C. Taubes, *A Framework for the Morse Theory for the Yang–Mills Functional*, Inventiones Mathematicae **24** (1988), 327–402.
- [18] C. Taubes, D. Kotschick and J.W. Morgan, *Four Manifolds without Symplectic Structure but with Non-trivial Seiberg–Witten Invariants*, Math. Res. Letter **2** (1995), 119–124.
- [19] K. Uhlenbeck, *Connections with L^p bounds on Curvature*, Comm. Math. Phys. **83** (1982), 31–42.
- [20] E. Witten, *Monopoles on Four Manifolds*, Math. Res. Lett. **1**, n°6 (1994), 769–796.
- [21] E. Witten, *Topological Quantum Field Theory*, Comm. Math. Phys. **117** (1988).
- [22] C.N. Yang and R.L. Mills, *Conservation of isotopic spin and isotopic gauge invariance*, Physical Rev. (2) **96** (1954), 191–195.

Celso Melchtiades Doria
Universidade Federal de Santa Catarina
Departamento de Matemática
Campus Universitário – Trindade
88040-900 Florianópolis – SC
Brazil
e-mail: cmdoria@mtm.ufsc.br
URL: <http://www.mtm.ufsc.br>

Some Recent Results on Equations Involving the Pucci's Extremal Operators

Patricio Felmer and Alexander Quaas

Abstract. In this article we review some recent results on equations involving the Pucci's extremal operators. We discuss the existence of eigenvalues and applications to bifurcation analysis. Then we turn to the study of critical exponents for positive solutions, reviewing some results for general solutions and for radially symmetric solutions. Then, some consequences for the existence of solutions for some semilinear equations are obtained. We finally indicate some open problems.

Mathematics Subject Classification (2000). 35B32, 35J20, 35J60.

Keywords. Critical exponents, Pucci's operators, fully nonlinear operators, Liouville type theorems, radial solutions .

1. Introduction

In this article we review some recent results in the theory of existence of solutions for some nonlinear equations involving the Pucci's extremal operators. These operators are prototypes for fully nonlinear second order differential operators and they are obtained as perturbations of the Laplacian. While retaining many properties of the Laplacian, they lose some crucial ones, opening many interesting and challenging questions regarding the existence of solutions.

In this respect let us remark that the theory of viscosity solutions provides a very general and flexible theory for the study of a large class of partial differential equations. While originally developed to understand first order equations, it was successfully extended to cover fully nonlinear second order elliptic and parabolic equations. Very general existence results are combined with regularity theory to obtain a complete theory. We refer to Crandall, Ishii and Lions [11] and, Cabré and Caffarelli [7] for the basic elements of the theory. For this theory to be applicable the fully nonlinear operator has to satisfy some structural hypotheses,

deeply linked to the Perron’s method of super and sub-solutions: maximum and comparison principles.

On the other hand, when the second order differential operator has divergence form, again there are many methods to study existence of solutions. These methods will take for granted the possibility of testing functions by integration, providing so a rich tool for the analysis. In this direction, this structural hypothesis allows to construct an associated functional, whose critical points provide the solutions one is looking for.

The hypotheses on the equation we are about to describe do not include maximum and comparison principles nor variational structure. Then we realize that there are few techniques available and the attempt to solve some seemingly simple and standard problems leads to some difficult questions.

Let us first recall the definition of the Pucci’s extremal operators. Given two parameters $0 < \lambda \leq \Lambda$, the matrix operators $\mathcal{M}_{\lambda,\Lambda}^+$ and $\mathcal{M}_{\lambda,\Lambda}^-$ are defined as follows: if M is a symmetric $N \times N$ matrix

$$\mathcal{M}_{\lambda,\Lambda}^+(M) = \Lambda \sum_{e_i > 0} e_i + \lambda \sum_{e_i < 0} e_i$$

and

$$\mathcal{M}_{\lambda,\Lambda}^-(M) = \lambda \sum_{e_i > 0} e_i + \Lambda \sum_{e_i < 0} e_i,$$

where $e_i = e_i(M)$, $i = 1, \dots, N$, are the eigenvalues of M . The Pucci’s operators are obtained applying $\mathcal{M}_{\lambda,\Lambda}^+$ or $\mathcal{M}_{\lambda,\Lambda}^-$ to the Hessian D^2u of the scalar function u . We observe that when $\lambda = \Lambda$ then both Pucci’s operators become equal to a multiple of the Laplacian. These two operators have many properties in common, but they are not equivalent. For more details and equivalent definitions see the monograph of Caffarelli and Cabré [7].

We start in Section §2 with the basic eigenvalues problems for the Pucci’s operator $\mathcal{M}_{\lambda,\Lambda}^+$, namely

$$\begin{aligned} -\mathcal{M}_{\lambda,\Lambda}^+(D^2u) &= \mu u \quad \text{in } \Omega, \\ u &= 0 \quad \text{on } \partial\Omega. \end{aligned} \tag{1.1}$$

One first question is the existence of a positive eigenfunction. It is addressed by Felmer and Quaas in [21] in the radial case and by Quaas in [44] for the case of a bounded domain using general Krein-Rutman’s Theorem in positive cones as in [48]. These results are related with a general result for positive homogeneous fully nonlinear elliptic operators by Rouy [49]. The method used there is due to P.L. Lions who proved results for the Bellman operator in [34] and for the Monge-Ampère operator in [35].

When the analysis is restricted to radially symmetric functions, then the full spectrum for (1.1) can be obtained and nice properties of complementarity among the spectra are disclosed in [6].

Once the spectra of the Pucci's operator is understood, Busca, Esteban and Quaas in [6] made a bifurcation analysis as developed by Rabinowitz in [47] and [48]. In this direction, several existence results are obtained in [6] for the equation

$$\begin{aligned} -\mathcal{M}_{\lambda,\Lambda}^+(D^2u) &= \mu u + f(u, \mu) \quad \text{in } \Omega, \\ u &= 0 \quad \text{on } \partial\Omega. \end{aligned} \tag{1.2}$$

where f is continuous, $f(s, \mu) = o(|s|)$ near $s = 0$, uniformly for $\mu \in \mathbb{R}$, and Ω is a general bounded domain.

The second main question we address in this review has to do with the so-called Liouville type theorems and is started in Section §4. In general terms the problem consists in determining the range for $p > 1$ for which the nonlinear elliptic equation

$$\mathcal{M}_{\lambda,\Lambda}^+(D^2u) + u^p = 0, \quad u \geq 0 \quad \text{in } \mathbb{R}^N, \tag{1.3}$$

does not have a non-trivial solution. Here $N \geq 3$.

The non-existence of positive solutions for (1.3) is evidently complementary to the question of existence and is related to the problem of existence in a bounded domain, via degree theory. This approach requires a priori bounds for the solutions that can be obtained via blow-up technique once a Liouville type theorem is available. This is the crucial importance of these non-existence results.

The first result in this direction is due to Cutri and Leoni [12] who obtained a general non-existence result for (1.3) whenever $1 < p \leq p_+^s := \tilde{N}_+ / (\tilde{N}_+ - 2)$, where the dimension-like number \tilde{N}_+ is given by $\tilde{N}_+ = \frac{\lambda}{\Lambda}(N - 1) + 1$. This remarkable result is actually true for supersolutions of (1.3), even in the viscosity sense.

One important open question is to obtain the full range of exponents for the general Liouville theorem. In the case of radial solutions, this problem was addressed by Felmer and Quaas in [19] and [20]. The existence of a critical number p_+^* is proved by means of a phase plane analysis after an Emden-Fowler transformation. This existence result is complemented by a uniqueness analysis resembling the study of uniqueness of ground states. The result in [20] clarifies the whole range of exponents, however it only gives an estimate of the critical exponent, whose value is between $(N + 2)/(N - 2)$ and $(\tilde{N}_+ + 2)/(\tilde{N}_+ - 2)$, remaining open to find a formula, in terms of the values of N , λ and Λ . It is important to mention the existence of an intermediate range of supercritical exponents where positive solutions in \mathbb{R}^N exist, but their behavior differs from those of the usual Laplacian.

Strongly related to Liouville type theorems in \mathbb{R}^N and also crucial for existence theory in bounded domains, are the non-existence results in half space. Here we will review a recent result of Quaas and Sirakov [45], where a dimension reduction approach in combination with Cutri and Leoni result is taken. In this way, a Liouville theorem is proved for general functions in the half space if the exponent is smaller than $(\tilde{N})/(\tilde{N} - 2)$, where $\tilde{N} = \frac{\lambda}{\Lambda}(N - 2) + 1$.

The third theme of this review is the existence theory for nonlinear equations with general form

$$\begin{aligned} \mathcal{M}_{\lambda,\Lambda}^+(D^2u) + f(u) &= 0 \quad \text{in } \Omega, \\ u &= 0 \quad \text{on } \partial\Omega. \end{aligned} \tag{1.4}$$

The results obtained so far are bounded by available Liouville type theorems. The idea used in all results is originated in a paper by de Figueiredo, Lions and Nussbaum [14], where a related problem for the Laplacian is considered. Through an ingenious homotopy it is possible to prove that the degree of a large set not including the origin is non-trivial, thus providing an existence theorem.

Using these techniques, Felmer and Quaas [21] proved the existence of a radially symmetric ground state for the equation

$$\begin{aligned} \mathcal{M}_{\lambda,\Lambda}^+(D^2u) - \gamma u + u^p &= 0 \quad \text{in } R^N, \\ \lim_{r \rightarrow \infty} u &= 0, \end{aligned} \tag{1.5}$$

if the exponent p is subcritical for the operator $\mathcal{M}_{\lambda,\Lambda}^+$. In a recent paper Felmer, Quaas and Tang in [26] have proved that this equation has actually only one solution. However, a second look at the problem reveals another open question. While solutions for (1.5) exists for all $1 < p < p_+^*$ we do not know if this exponent is optimal.

We will see also some recent existence results for equation (1.4), when Ω is a bounded domain in \mathbb{R}^N . In [18] Esteban, Felmer and Quaas obtain existence of positive solutions for the equation (1.3) for domains which are perturbations of a ball. These results provide with evidence that the critical exponent p_*^+ , whose validity so far is confined to radially symmetric functions, is also a critical exponent for general domains. In [18] other related operators are also considered.

Finally we want to point out that all results discussed above can also be obtained for the operator $\mathcal{M}_{\lambda,\Lambda}^-$, without substantial changes. For other results concerning singular solutions for the Pucci’s operators, we refer the reader to the work of Labutin in [32] and [33].

2. Eigenvalues for the Pucci’s operator

As already mentioned in the introduction, the solvability of fully nonlinear elliptic equations of the form

$$F(x, u, Du, D^2u) = 0 \tag{2.1}$$

is very well understood for *coercive* uniformly elliptic operators F . On the contrary, little is known when coercivity (that is, monotonicity in u) is dropped. The aim is to study the model problem (1.4) when Ω is a bounded regular domain. In relation to (1.4) it is convenient to consider an eigenvalue problem that could provide some information on the general case. Since $\mathcal{M}_{\lambda,\Lambda}^+$ is homogeneous of degree one, it is natural to consider the “eigenvalue problem” (1.1).

Before continuing with our analysis we want to mention that Pucci's extremal operators appear in the context of stochastic control when the diffusion coefficient is a control variable, see the book of Bensoussan and J.L. Lions [1] or the papers of P.L. Lions [37], [38], [39] for the relation between a general Hamilton-Jacobi-Bellman and stochastic control. They also provide natural extremal equations in the sense that if F in (2.1) is uniformly elliptic, with ellipticity constants λ, Λ , and depends only on the Hessian D^2u , then

$$\mathcal{M}_{\lambda, \Lambda}^-(M) \leq F(M) \leq \mathcal{M}_{\lambda, \Lambda}^+(M) \tag{2.2}$$

for any symmetric matrix M . When $\lambda = \Lambda = 1$, (1.1) simply reduces to

$$\begin{aligned} -\Delta u &= \mu u \quad \text{in } \Omega, \\ u &= 0 \quad \text{on } \partial\Omega. \end{aligned} \tag{2.3}$$

It is a very well known fact that there exists a sequence of solutions

$$\{(\mu_n, \varphi_n)\}_{n \geq 1}$$

to (2.3) such that:

- i) The eigenvalues $\{\mu_n\}_{n \geq 1}$ are real, with $\mu_n > 0$ and $\mu_n \rightarrow \infty$ as $n \rightarrow \infty$.
- ii) The set of all eigenfunctions $\{\varphi_n\}_{n \geq 1}$ is a basis of $L^2(\Omega)$.

Building on these eigenvalues, the classical Rabinowitz bifurcation theory [47], [48] allows to give general answers on existence of solutions to semilinear problems for the Laplacian.

When $\lambda < \Lambda$, problems (1.1) and (1.4) are fully nonlinear and it is interesting to know to which extent the known results about the Laplace operator can be generalized to this context. A few partial results in this direction have been established in the recent years. In [6] the authors provide a bifurcation result for general nonlinearities from the first two "half-eigenvalues" in general bounded domains. And in the radial case a complete description of the spectrum and the bifurcation branches for a general nonlinearity from any point in the spectrum.

Let us mention that besides the fact that (1.1)-(1.4) appears to be a favorable case from which one might hope to address general problems like (2.1), there are other reasons why one should be interested in Pucci's extremal operators or, more generally, in Hamilton-Jacobi-Bellman operators, which are envelopes of linear operators. The Pucci's operators are related to the Fućik operator as we describe next. Let u be a solution of nonlinear elliptic equation

$$-\Delta u = \mu u^+ - \alpha \mu u^-,$$

where α is a fixed positive number. One easily checks that if $\alpha \geq 1$, then u satisfies

$$\max\{-\Delta u, \frac{-1}{\alpha} \Delta u\} = \mu u,$$

whereas if $\alpha \leq 1$, u satisfies

$$\min\{-\Delta u, \frac{-1}{\alpha} \Delta u\} = \mu u.$$

These relations mean that the Fučík spectrum can be seen as the spectrum of the maximum or minimum of two linear operators, whereas (1.1)-(1.4) deal the maximum or minimum of an infinite family of operators.

We recall here that understanding the “spectrum” the Fučík operator, even in dimension $N = 2$, is still largely an open question. Only partial results are known and, in general, they refer to a region near the usual spectrum, (that is for α near 1). For a further discussion of this topic, we refer the interested reader to the works of de Figueiredo and Gossez [24], H. Berestycki [2], E.N. Dancer [13], S. Fučík [27], P. Drábek [17], T.Gallouet and O. Kavian [28], M. Schechter [50] and the references therein.

The first result in [6] deals with the existence and characterizations of the two first “half-eigenvalues” for $\mathcal{M}_{\lambda,\Lambda}^+$.

Theorem 2.1. *Let Ω be a regular domain, then there exist two positive constants μ_1^+, μ_1^- , that we call first half-eigenvalues such that:*

- i) *There exist two functions $\varphi_1^+, \varphi_1^- \in C^2(\Omega) \cap C(\bar{\Omega})$ such that (μ_1^+, φ_1^+) , (μ_1^-, φ_1^-) are solutions to (1.1) and $\varphi_1^+ > 0, \varphi_1^- < 0$ in Ω . Moreover, these two half-eigenvalues are simple, that is, all positive solutions to (1.1) are of the form $(\mu_1^+, \alpha\varphi_1^+)$, with $\alpha > 0$. The same holds for the negative solutions.*
- ii) *The two first half-eigenvalues satisfy*

$$\mu_1^+ = \inf_{A \in \mathcal{A}} \mu_1(A), \quad \mu_1^- = \sup_{A \in \mathcal{A}} \mu_1(A),$$

where \mathcal{A} is the set of all symmetric measurable matrices such that $0 < \lambda I \leq A(x) \leq \Lambda I$ and $\mu_1(A)$ is the principal eigenvalue of the nondivergent second order linear elliptic operator associated to A .

- iii) *The two half-eigenvalues have the following characterization*

$$\mu_1^+ = \sup_{u > 0} \operatorname{ess\,inf}_{\Omega} \left(-\frac{\mathcal{M}_{\lambda,\Lambda}^+(D^2u)}{u} \right), \quad \mu_1^- = \sup_{u < 0} \operatorname{ess\,inf}_{\Omega} \left(-\frac{\mathcal{M}_{\lambda,\Lambda}^-(D^2u)}{u} \right).$$

The supremum is taken over all functions $u \in W_{loc}^{2,N}(\Omega) \cap C(\bar{\Omega})$.

- iv) *The first half-eigenvalues can be also characterized by*

$$\mu_1^+ = \sup\{\mu \mid \text{there exists } \phi > 0 \text{ in } \Omega \text{ satisfying } \mathcal{M}_{\lambda,\Lambda}^+(D^2\phi) + \mu\phi \leq 0\}$$

and

$$\mu_1^- = \sup\{\mu \mid \text{there exists } \phi < 0 \text{ in } \Omega \text{ satisfying } \mathcal{M}_{\lambda,\Lambda}^+(D^2\phi) + \mu\phi \geq 0\}.$$

The above existence result, that is part i) of Theorem 2.1, is proved using a modified version, for convex (or concave) operators, of Krein-Rutman’s Theorem in positive cones (see [21] in the radial symmetric case and see [44] in the case of a regular bounded domain).

This existence result has been also proved in the case of general positive homogeneous fully nonlinear elliptic operators in the paper by Rouy [49]. The

method used there is due to P.L. Lions who proved the result i) of Theorem 2.1 for the Bellman operator in [34] and for the Monge-Ampère operator in [35].

Properties ii) of Theorem 2.1 can be generalized to any fully nonlinear elliptic operator F that is positively homogeneous of degree one, with ellipticity constants λ, Λ . This follows by the proof of ii) and (2.2). These properties were established by C. Pucci in [42], for related extremal operators.

The characterization of the form iii) and iv) for the first eigenvalue, was introduced by Berestycki, Nirenberg and Varadhan for second order linear elliptic operators in [5]. From iv) it follows that

$$\mu_1^+(\Omega) \leq \mu_1^+(\Omega') \quad \text{and} \quad \mu_1^-(\Omega) \leq \mu_1^-(\Omega') \quad \text{if} \quad \Omega' \subset \Omega.$$

In [6] many other properties for the two first half-eigenvalues are deduced from Theorem 2.1. For example, whenever $\lambda \neq \Lambda$, we have $\mu_1^+ < \mu_1^-$, since $\mu_1^+ \leq \lambda \mu_1(-\Delta) \leq \Lambda \mu_1(-\Delta) \leq \mu_1^-$. Another interesting and useful property is the following maximum principle.

Theorem 2.2. *The next two maximum principles hold:*

a) *Let $u \in W_{loc}^{2,N}(\Omega) \cap C(\bar{\Omega})$ satisfy*

$$\begin{aligned} \mathcal{M}_{\lambda,\Lambda}^+(D^2u) + \mu u &\geq 0 \quad \text{in } \Omega, \\ u &\leq 0 \quad \text{on } \partial\Omega. \end{aligned} \tag{2.4}$$

If $\mu < \mu_1^+$, then $u \leq 0$ in Ω .

b) *Let $u \in W_{loc}^{2,N}(\Omega) \cap C(\bar{\Omega})$ satisfy*

$$\begin{aligned} \mathcal{M}_{\lambda,\Lambda}^-(D^2u) + \mu u &\leq 0 \quad \text{in } \Omega, \\ u &\geq 0 \quad \text{on } \partial\Omega. \end{aligned} \tag{2.5}$$

If $\mu < \mu_1^-$, then $u \geq 0$ in Ω .

The study of higher eigenvalues for the Pucci's operator in a general domain is wide open, as for general second order linear operators. However, in the radial case a complete description of the whole "spectrum" is given in [6]. This result may shed some light on the general case. More precisely, we have the following theorem.

Theorem 2.3. *Let $\Omega = B_1$. The set of all the scalars μ such that (1.1) admits a nontrivial radial solution, consists of two unbounded increasing sequences*

$$\begin{aligned} 0 < \mu_1^+ < \mu_2^+ < \dots < \mu_k^+ < \dots, \\ 0 < \mu_1^- < \mu_2^- < \dots < \mu_k^- < \dots. \end{aligned}$$

Moreover, the set of radial solutions of (1.1) for $\mu = \mu_k^+$ is positively spanned by a function φ_k^+ , which is positive at the origin and has exactly $k-1$ zeros in $(0, 1)$, all these zeros being simple. The same holds for $\mu = \mu_k^-$, but considering φ_k^- negative at the origin.

This theorem is proved solving an appropriate initial value problem and a corresponding scaling. All nodal eigenfunction are generated in this way. There are many interesting questions left open in [6] regarding the distribution of these eigenvalues. For example: is it true that $\mu_k^+ \leq \mu_k^-$?

3. Bifurcation Analysis for the Pucci’s operator

In this section we describe the results obtained in [6] regarding bifurcation of solutions that can be obtained now that we know spectral properties of the extremal Pucci’s operator. In precise terms we consider (1.2) when f is continuous, $f(s, \mu) = o(|s|)$ near $s = 0$, uniformly for $\mu \in \mathbb{R}$, and Ω is a general bounded domain. Concerning this problem we have the following theorem

Theorem 3.1. *The pair $(\mu_1^+, 0)$ (resp. $(\mu_1^-, 0)$) is a bifurcation point of positive (resp. negative) solutions to (1.2). Moreover, the set of nontrivial solutions of (1.2) whose closure contains $(\mu_1^+, 0)$ (resp. $(\mu_1^-, 0)$), is either unbounded or contains a pair $(\bar{\mu}, 0)$ for some $\bar{\mu}$, eigenvalue of (1.1) with $\bar{\mu} \neq \mu_1^+$ (resp. $\bar{\mu} \neq \mu_1^-$).*

For the Laplacian this result is well known, see [46], [47] and [48]. In this case the “half-branches” become connected. Therefore, we observe a symmetry breaking phenomena when $\lambda < \Lambda$.

For the p -Laplacian the result is also known, in the general case, see the paper of del Pino and Manásevich [16]. See also the paper of del Pino, Elgueta and Manásevich [15], for the case $N = 1$. In this case the branches are also connected. The proof of these results uses an invariance under homotopy with respect to p for the Leray-Schauder degree. In the proof of Theorem 3.1 homotopy invariance with respect to the ellipticity constant λ is used instead, having to deal with a delicate region in which the degree is equal to zero.

A bifurcation result in the particular case $f(u, \mu) = -\mu|u|^{p-1}u$ can be found in the paper by P.L. Lions for the Bellman equation [34]. For the problem

$$-\mathcal{M}_{\lambda, \Lambda}^+(D^2u) = \mu g(x, u) \quad \text{in } \Omega, \quad u = 0 \quad \text{on } \partial\Omega$$

with the following assumption on g :

(g0) $u \rightarrow g(x, u)$ is nondecreasing and $g(x, 0) = 0$,

(g1) $u \rightarrow \frac{g(x, u)}{u}$ decreasing, and

(g2) $\lim_{u \rightarrow 0} \frac{g(x, u)}{u} = 1, \quad \lim_{u \rightarrow \infty} \frac{g(x, u)}{u} = 0$,

a similar result was proved by E. Rouy [49]. In [34] and [49] the assumptions on g play a crucial role to construct sub and super-solutions. By contrast, in [6] the use of a Leray-Schauder degree argument allows to treat more general nonlinearities.

In the radially symmetric case the authors obtain a more complete result. Their proof again is based on the invariance of the Leray-Schauder degree under homotopy.

Theorem 3.2. *Let $\Omega = B_1$. For each $k \in \mathbb{N}$, $k \geq 1$ there are two connected components S_k^\pm of nontrivial solutions to (1.2), whose closures contains $(\mu_k^\pm, 0)$. Moreover, S_k^\pm are unbounded and $(\mu, u) \in S_k^\pm$ implies that u possesses exactly $k - 1$ zeros in $(0, 1)$.*

Remark 3.1. S_k^+ (resp. S_k^-) denotes the set of solutions that are positive (resp. negative) at the origin.

For the Laplacian this result is well known. In this case, for all $k \geq 1$, $\mu_k^+ = \mu_k^-$ and the ‘‘half-branches’’ connect each other at the bifurcation point.

4. Critical Exponents for the Pucci's Operators

In this section we consider the study of solutions to the nonlinear elliptic equation (1.3) where $N \geq 3$, $p > 1$. When $\lambda = \Lambda = 1$ (1.3) becomes

$$\Delta u + u^p = 0, \quad u \geq 0 \quad \text{in } \mathbb{R}^N. \tag{4.1}$$

This very well known equation has a solution set whose structure depends on the exponent p . When $1 < p < p^* := (N + 2)/(N - 2)$ then equation (4.1) has no nontrivial solution vanishing at infinity, as can be proved using the celebrated Pohozaev identity [43]. If $p = p^*$ then it is shown by Caffarelli, Gidas and Spruck in [9] that, up to scaling, equation (4.1) possesses exactly one solution. This solution behaves like $C|x|^{2-N}$ near infinity. When $p > p^*$ then equation (4.1) admits radial solutions behaving like $C|x|^{-\alpha}$ near infinity, where $\alpha = 2/(p - 1)$. The critical character of p^* is enhanced by the fact that it intervenes in compactness properties of Sobolev spaces, a reason for being known as critical Sobolev exponent.

It is interesting to mention that the nonexistence of solutions to (4.1) when $1 < p < p^*$ holds even if we do not assume a given behavior at infinity. This Liouville type theorem was proved by Gidas and Spruck in [23]. When $1 < p \leq N/(N - 2) := p^s$, then a Liouville type theorem is known for supersolutions of (4.1).

This number p^s is called sometimes the second critical exponent or Serrin exponent for (4.1). In a recent paper [12], Cutri and Leoni extend this result for the Pucci's extremal operators. They consider the inequality

$$\mathcal{M}_{\lambda, \Lambda}^+(D^2u) + u^p \leq 0, \quad u \geq 0 \quad \text{in } \mathbb{R}^N, \tag{4.2}$$

and define the dimension-like number $\tilde{N}_+ = \frac{\Lambda}{\lambda}(N - 1) + 1$. Then they prove that for $1 < p \leq p_+^s := \tilde{N}_+ / (\tilde{N}_+ - 2)$ equation (4.2) has only the trivial solution.

In view of the results for the semilinear equation (4.1) that we have discussed above and the new results for inequality (4.2) just mentioned, it is natural to ask about the existence of critical exponents of the Sobolev type for (1.3). In particular it would be interesting to understand the structure of solutions for equation (1.3) in terms for different values of $p > 1$. It would also be interesting to prove Liouville type theorems for positive solutions in \mathbb{R}^N and to understand the mechanisms for existence of positive solutions in general bounded domains.

In [19] Felmer and Quaas obtained some results in the case of radially symmetric solutions. Before we state the results we give a definition to classify the possible radial solutions of equation (4.1).

Definition 4.1. *Assume u is a radial solution of (1.3) then we say that:*

- i) u is a pseudo-slow decaying solution if there exist constants $C_2 > C_1 > 0$ such that $C_1 = \liminf_{r \rightarrow \infty} r^\alpha u(r) < \limsup_{r \rightarrow \infty} r^\alpha u(r) = C_2$.
- ii) u is a slow decaying solution if there exists $c^* > 0$ such that $\lim_{r \rightarrow \infty} r^\alpha u(r) = c^*$.
- iii) u is a fast decaying solution if there exists $C > 0$ such that $\lim_{r \rightarrow \infty} r^{\tilde{N}-2} u(r) = C$.

The main results in [19] are summarized in the following theorem.

Theorem 4.1. *Suppose that $\tilde{N}_+ > 2$. Then there are critical exponents $1 < p_+^s < p_+^* < p_+^p$, with $p_+^s = \tilde{N}_+ / (\tilde{N}_+ - 2)$, $p_+^p = (\tilde{N}_+ + 2) / (\tilde{N}_+ - 2)$ and $\max\{p_+^s, p_+^*\} < p_+^* < p_+^p$, that satisfy:*

- i) *If $1 < p < p_+^*$ then there is no nontrivial radial solution of (1.3).*
- ii) *If $p = p_+^*$ then there is a unique fast decaying radial solution of (1.3).*
- iii) *If $p^* < p \leq p_+^p$ then there is a unique pseudo-slow decaying radial solution to (1.3).*
- iv) *If $p_+^p < p$ then there is a unique slow decaying radial solution to (1.3).*

Here uniqueness is understood up to scaling. The approach in [19] consists in a combination of the Emden-Fowler phase plane analysis with the Coffman-Kolodner technique. We start considering the classical Emden-Fowler transformation that allows to view the problem in the phase plane. With the aid of suitable energy functions much of the behavior of the solutions is understood. Their asymptotic behavior is obtained in some cases using the Poincaré-Bendixon theorem. This phase plane analysis has been used in related problems by Clemons and Jones [10], Kajikiya [29] and Erbe and Tang [26] among many others.

On the other hand we use the Coffman-Kolodner technique which consists in differentiating the solution with respect to a parameter. The function so obtained possesses valuable information on the problem. This idea has been used by several authors in dealing with uniqueness questions differentiating with respect to the initial value. In particular, see the work by Kwong [30], Kwong and Zhang [31] and Erbe and Tang [26]. However in [20] the authors do not differentiate with respect to the initial value, which is kept fixed, but with respect to the power p . Thus the variation function satisfies a non-homogeneous equation, in contrast with the situations treated earlier.

When the Pucci’s extremal operators is considered on radially symmetric functions, it takes a very simple form so we can consider the following initial value problem

$$u'' = M \left(\frac{-\lambda(N-1)}{r} u' - u^p \right), \quad r > 0, \quad u(0) = \gamma, \quad u'(0) = 0, \quad (4.3)$$

where $\gamma > 0$ and $M(s) = s/\Lambda$ if $s \geq 0$ and $M(s) = s/\lambda$ if $s < 0$. We notice that this equation possesses a unique solution that we denote by $u(r, p, \gamma)$ and that non-negative solutions of (4.3) correspond to radially symmetric solutions of (1.3). It can be proved that the solutions of (4.3) are decreasing, while they remain positive and that they have the following scaling property: $\gamma u(\gamma^{1/\alpha}r, p, \gamma_0) = u(r, p, \gamma_0\gamma)$, for all $\gamma_0, \gamma > 0$.

In the next definition we classify the exponent p according to the behavior of the solution of the initial value problem (4.3) according to Definition 4.1. We define:

$$\begin{aligned} \mathcal{C} &= \{p \mid p > 1, \quad u(r, p, \gamma) \text{ has a finite zero}\} \\ \mathcal{P} &= \{p \mid p > 1, \quad u(r, p, \gamma) > 0 \text{ and is pseudo-slow decaying}\} \\ \mathcal{S} &= \{p \mid p > 1, \quad u(r, p, \gamma) > 0 \text{ and is slow decaying}\} \\ \mathcal{F} &= \{p \mid p > 1, \quad u(r, p, \gamma) > 0 \text{ and is fast decaying}\}. \end{aligned}$$

In view of the scaling property, we notice that these sets do not depend on the particular value of $\gamma > 0$.

An important step in the proof is to perform the classical Emden-Fowler change of variables $x(t) = r^\alpha u(r)$, $r = e^t$. This allows to use phase plane analysis. We have that the initial value problem (4.3) reduces to the autonomous differential equation

$$x'' = -\alpha(\alpha + 1)x + (1 + 2\alpha)x' + M(\lambda(N - 1)(\alpha x - x') - x^p), \tag{4.4}$$

with boundary condition $x(-\infty) = 0$, $x'(-\infty) = 0$. Studying this dynamical system one can obtain the following basic properties:

- a) If $p > \frac{\tilde{N}+2}{N-2}$ then $p \in \mathcal{S}$.
- b) If $p \leq \max\{\frac{\tilde{N}}{N-2}, \frac{N+2}{N-2}\}$ then $p \in \mathcal{C}$.
- c) $\frac{\tilde{N}+2}{N-2} \in \mathcal{P}$ and if $p \leq \frac{\tilde{N}+2}{N-2}$, then $p \notin \mathcal{S}$.
- d) $\mathcal{P} \setminus \{\frac{\tilde{N}+2}{N-2}\}$ is open.

In the proof of these propositions we use two energy like functions

$$e(t) = \frac{(x')^2}{2} + \frac{\alpha x^{p+1}}{2\lambda(N-1)} - \frac{(\alpha x)^2}{2}, \quad E(t) = \frac{(x')^2}{2} + \frac{x^{p+1}}{\Lambda(p+1)} - \frac{\tilde{b}x^2}{2},$$

in order to understand the behavior of the trajectories. The Poincaré-Bendixon theorem is also used. It is interesting to note that in the range of p where the solution is pseudo-slow decaying, the periodic orbit of the dynamical system corresponds to a singular solution to $\mathcal{M}_{\lambda, \Lambda}^+(D^2u) + u^p = 0$, which change infinitely many times its concavity. These solutions are not present in the case of the Laplacian and appear in trying to compensate the fact that $\lambda < \Lambda$.

The second main step in the proof of the main theorem in [20] is to understand the nature of the solutions obtained near a fast decaying solution. The goal is to prove that \mathcal{F} is a Singleton. As we mentioned, the idea is to differentiate the

solution of (4.3) with respect to p . The resulting function φ has valuable information on the solutions near the fast decaying one. By analyzing φ one can prove the following crucial proposition.

Proposition 4.1. a) *If $q \in \mathcal{F}$, then for $p < q$ close to q we have $p \in \mathcal{C}$.*
 b) *If $q \in \mathcal{F}$, then for $p > q$ close to q we have $p \in \mathcal{S} \cup \mathcal{P}$.*

In order to understand the asymptotic behavior of φ it is convenient to study the function $w = w_\theta(r) = r^\theta u(r, q)$, for $\theta > 0$ chosen so that $\theta = (\tilde{N} - 1)/2$ if $\tilde{N} > 3$ and $\theta = (\tilde{N} - 2)/2$ if $2 < \tilde{N} \leq 3$. This function was introduced by Erbe and Tang in [26], for a related problem. Defining $y(r) = \frac{\partial w(r)}{\partial p} = r^\theta \varphi$, when $\tilde{N} > 3$, y satisfies the equation

$$y'' + \left(\frac{(\tilde{N} - 1)(3 - \tilde{N})}{4r^2} + \frac{qu^{q-1}}{\Lambda} \right) y + r^\theta \frac{u^q}{\Lambda} \log u = 0 \quad \text{if } r > r_0. \tag{4.5}$$

Using the fact that u is a fast decaying solution we find that the coefficient in the second term of (4.5) is negative for r large. A similar situation occurs when $2 < \tilde{N} \leq 3$. The following lemma on the asymptotic behavior of y is crucial in proving Proposition 4.1.

Lemma 4.1. *The function y defined above satisfies $y(r) > 0$ and $y'(r) > 0$ for r large.*

Finally, the proof of Theorem 4.1 is a direct consequence of previous Propositions, the openness of \mathcal{C} and $\mathcal{P} \setminus \left\{ \frac{\tilde{N}_+ + 2}{\tilde{N}_+ - 2} \right\}$.

5. Semi-linear equations and Liouville type Theorems

Having proved the existence of the critical exponents for (1.3) one can look for solutions for similar equations but in a bounded domain. Consider (1.4) when $\Omega = B_R$ is the ball of radius R in \mathbb{R}^N and f is an appropriate nonlinearity. When $\lambda = \Lambda = 1$, (Laplace operator case) (1.4) has been studied by many authors, not only in a ball, but on general domains. We refer the reader to the review paper by P.L. Lions [36] and the references therein.

Continuing with the description of the results, let us introduce the precise assumptions on the nonlinearity f :

- (f0) $f(u) = -\gamma u + g(u)$, $g \in C([0, +\infty))$ and is locally Lipschitz.
- (f1) $g(s) \geq 0$ and there is $1 < p < p_+^*$ and a constant $C^* > 0$ such that

$$\lim_{s \rightarrow +\infty} \frac{g(s)}{s^p} = C^*.$$

- (f2) There is a constant $c^* \geq 0$ such that $c^* - \gamma < \mu_1^+$ and

$$\lim_{s \rightarrow 0} \frac{f(s)}{s} = c^*,$$

where μ_1^+ is the first half eigenvalue for $\mathcal{M}_{\lambda, \Lambda}^+$ in B_R .

The first model problem is $f(s) = -u + s^p$, $1 < p < p_+^*$. The second model problem is $f(s) = \alpha s + s^p$, $1 < p < p_+^*$ and $0 \leq \alpha < \mu_1^+$.

Now we are in a position to state the main theorem by Felmer and Quaas in [21]

Theorem 5.1. *Assume $N \geq 3$ and f satisfies the hypotheses (f0), (f1) and (f2). Then there exist a positive radially symmetric C^2 solution of (1.4).*

In case of the first model problem, Theorem 5.1 can be extended for positive solutions in \mathbb{R}^N . Precisely we have

Theorem 5.2. *Assume $N \geq 3$ and $1 < p < p_+^*$. Then there is a positive radially symmetric C^2 solution of the equation*

$$\mathcal{M}_{\lambda, \Lambda}^+(D^2u) - u + u^p = 0 \quad \text{in } \mathbb{R}^N. \tag{5.1}$$

In order to prove Theorem 5.1 the author use degree theory on positive cones as presented in the work by de Figueiredo, Lions and Nussbaum in [14]. A priori bounds for solutions are obtained by blow up method introduced by Gidas and Spruck [23] in combination with the Liouville type Theorem 4.1.

Following in this direction and in view of Cutri and Leoni theorem in [12], it is interesting to ask if the theory of viscosity solutiouns allows to use a degree argument. Consider the existence of positive solutions for the equation (1.4) when Ω is a convex domain in \mathbb{R}^N with boundary $\partial\Omega$ of class $C^{2,\alpha}$ and f is an appropriate nonlinearity.

On the nonlinearity f we consider the hypotheses (f0), (f1) and (f2). With the difference that in (f1) we assume $1 < p < p_+^*$ and in (f2) μ_1^+ is the first half eigenvalue for $\mathcal{M}_{\lambda, \Lambda}^+$ in Ω , as given in Section §2.

Now we are in a position to state the main theorem in [44]

Theorem 5.3. *Assume $N \geq 3$, Ω is convex and f satisfies the hypotheses (f0), (f1) and (f2). Then there exist a positive $C^2(\Omega)$ solution of (1.4).*

Remark 5.1. *The missing piece to cover all $1 < p < p_+^*$ in (f1) is the Louville type theorem in the general case, which remains open.*

In order to prove our main theorem the author uses the Liouville type Theorem of Cutri and Leoni. At this point the convexity of the domain plays a crucial role. In fact, the convexity Ω allows to prove, via moving planes, that the blow-up point always converges to the interior of Ω . As we see in what follows the convexity of Ω can be lifted as proved by Quaas and Sirakov in [45].

Theorem 5.4. *Suppose $N \geq 3$ and set*

$$\tilde{p}_+ = \frac{\Lambda(N - 2) + \lambda}{\Lambda(N - 2) - \lambda}.$$

Then the problem

$$\begin{aligned} \mathcal{M}_{\lambda, \Lambda}^+(D^2u) + u^p &= 0 && \text{in } \mathbb{R}_+, \\ u &= 0 && \text{on } \partial\mathbb{R}_+ \end{aligned}$$

does not have a positive nontrivial bounded solution, provided $1 < p \leq \tilde{p}_+$. Observe that $\tilde{p}_+ > p_+^s$.

A Theorem of this type for the equation $-\Delta u + f(u) = 0$ was first obtained by Dancer in [13]. Theorem 5.4 is proved by using a (simplified) version of the proof of Berestycki, Caffarelli and Nirenberg [3], who showed that solutions of $\Delta u + f(u) = 0$ in a half space which are at most exponential at infinity are necessarily monotone in x_N . Once this is proved it is possible to pass to the limit as $x_N \rightarrow \infty$, and this leads to a solution of the same problem in \mathbb{R}^{N-1} , which permits the use of Liouville Theorems of Cutri and Leoni in the whole space.

The following existence result is a consequence.

Theorem 5.5. *Assume $N \geq 3$ and f satisfies the same condition as Theorem 5.3. Then for any bounded regular domain Ω there exists a positive $C^2(\Omega)$ solution of (1.4).*

Remark 5.2. *The missing part to cover the range $p_+^s < p < p_+^*$ in (f1) is the general Liouville type theorem in \mathbb{R}^N which is still open. In fact, a Liouville type Theorem in all space would imply a Liouville type Theorem in the half space for a larger range of p .*

6. Further questions and open problems

For any linear second order uniformly elliptic operator with C^1 coefficients, say $Lu = \sum_i \sum_j a_{ij} \frac{\partial u^2}{\partial x_i \partial x_j}$ with $a_{ij} \in C^1$, the semilinear problem

$$Lu + u^p = 0, \quad \text{in } \Omega \tag{6.1}$$

$$u = 0, \quad \text{on } \partial\Omega, \tag{6.2}$$

has a positive solution for the same range of values of p as for the Laplacian. That is, the existence property of the Sobolev exponent remains valid for all operators in this class.

In [18] Esteban, Felmer and Quaas consider two classes of uniformly second order elliptic operators for which the critical exponents in the radially symmetric case are drastically changed with respect to the Sobolev exponent p^* . The main point in [18] is to prove that the corresponding existence property for these critical exponents persists when the domain is perturbed, away from the ball.

The first class of operators corresponds to the Pucci’s extremal ones, that is, $\mathcal{M}_{\lambda,\Lambda}^+(D^2u)$ and $\mathcal{M}_{\lambda,\Lambda}^-(D^2u)$, already discussed in this paper. We recall that these are extremal operators in the class defined by (2.2) and we notice that given any number $s \in [\lambda, \Lambda]$ the operator $s\Delta$ belongs to the class defined by (2.2).

The second family of operators that are considered in [18] are defined as

$$Q_{\lambda,\Lambda}^+ u = \lambda\Delta u + (\Lambda - \lambda)Q^0 u, \tag{6.3}$$

where Q^0 is the second order linear operator

$$Q^0u = \sum_{i=1}^N \sum_{j=1}^N \frac{x_i x_j}{|x|^2} \frac{\partial^2 u}{\partial x_i \partial x_j}.$$

These operators are also considered by Pucci [42], being extremal with respect to some spectral properties. We notice that these operators belong to the class defined by (2.2) and when $\lambda = \Lambda$ they also become a multiple of the Laplacian. If we interchange the role of λ by Λ in definition (6.3) then we obtain the operator $Q_{\lambda, \Lambda}^-$, which is also considered later.

The operators $\mathcal{M}_{\lambda, \Lambda}^\pm$ are autonomous, but not linear, even if they enjoy some properties of the Laplacian. The operators $Q_{\lambda, \Lambda}^\pm$ are still linear, but their coefficients are not continuous at the origin. When one considers a ball and the set of radially symmetric functions on it, there are critical exponents for the operators \mathcal{M}^+ and Q^+ which are greater than the Sobolev exponent p^* . On the contrary, for the operators $Q_{\lambda, \Lambda}^-$ and $\mathcal{M}_{\lambda, \Lambda}^-$, the critical exponents for radially symmetric solutions in a ball are smaller than the Sobolev exponent p^* . We recall

$$\frac{\tilde{N}_- + 2}{\tilde{N}_- - 2} < p_-^* < p^* < p_+^* < \frac{\tilde{N}_+ + 2}{\tilde{N}_+ - 2},$$

where the numbers in the extreme are the critical exponents of Q^- and Q^+ , respectively. The numbers p_+^* and p_-^* depend on λ , Λ and the dimension N .

Open problem 1. Determine an explicit formula for the numbers p_+^* and p_-^* , or at least describe in more precise terms the dependence with respect to the parameters.

The existense results in [18] are for domains which are close to the unit ball. More precisely it is assumed that there is a sequence of domains $\{\Omega_n\}$ such that for all $0 < r < 1 < R$ there exists $n_0 \in \mathbb{N}$ such that

$$B(0, r) \subset \Omega_n \subset B(0, R), \quad \text{for all } n \geq n_0.$$

Then the main theorem is

Theorem 6.1. *Assume $\tilde{N}_+ > 2$ and that $1 < p < (\tilde{N}_+ + 2)/(\tilde{N}_+ - 2)$. Then there is $n_0 \in \mathbb{N}$ so that for all $n \geq n_0$, the equation*

$$Qu + u^p = 0 \quad \text{in } \Omega_n, \tag{6.4}$$

$$u = 0 \quad \text{on } \partial\Omega_n, \tag{6.5}$$

possesses at least one nontrivial solution.

A second theorem states a similar result replacing Q^+ by $\mathcal{M}_{\lambda, \Lambda}^+$. Corresponding theorems for Q^- and $\mathcal{M}_{\lambda, \Lambda}^-$ are also considered.

Thus, in this work it is proved that the phenomenon of critical exponent increase (or decrease) does not appear only in the radially symmetric case, but persists when the ball is perturbed not necessarily in a radial manner. This result is proved by a perturbation argument, based on a work by Dancer [13]. It provides

evidence that the critical exponents for these operators, obtained in radial versions, are also the critical exponents in the general case.

At this point we would like to stress some surprising properties of the critical exponents of operators in the class given by (2.2). For the first property we consider all linear elliptic operators with bounded coefficients and belonging to the class defined by (2.2). If we take the L^∞ topology for the coefficients of these operators, we see that the critical exponent is not a continuous function of the operator. In particular, as shown in Section §2, the operators $Q_{\lambda,\Lambda}^-$ can be “approximated” in L^∞ (the coefficients) by a sequence of operators with C^∞ coefficients, for which the critical exponent in the radially symmetric case is p^* .

The second property is related to the non-monotonicity of the critical exponents. Notice the following inequality for operators holds,

$$\lambda\Delta \leq \mathcal{M}_{\lambda,\Lambda}^+ \quad \text{and} \quad Q_{\lambda,\Lambda}^+ \leq \mathcal{M}_{\lambda,\Lambda}^+,$$

while for the corresponding critical exponents we have

$$p^* < p_+^* \quad \text{and} \quad \frac{\tilde{N}_+ + 2}{\tilde{N}_+ - 2} > p_+^*.$$

Open problem 2. Is there a natural order in the operators that is compatible with the order of the critical exponents?

We finally observe that all operators of the form $\mathcal{M}_{s,S}^\pm$ and $Q_{s,S}^\pm$, with $s, S \in [\lambda, \Lambda]$, have critical exponents in the interval

$$\left[\frac{\tilde{N}_- + 2}{\tilde{N}_- - 2}, \frac{\tilde{N}_+ + 2}{\tilde{N}_+ - 2} \right].$$

Open problem 3. Prove that in the class of operators defined by (2.2), all the critical exponents are in the same interval, that is, the operators $Q_{\lambda,\Lambda}^\pm$ are extremal for critical exponents.

Acknowledgments. The first author was partially supported by Fondecyt Grant # 1030929 and FONDAP de Matemáticas Aplicadas and the second author was partially supported by Fondecyt Grant # 1040794.

References

- [1] A. Bensoussan and J.L. Lions, *Applications of variational inequalities in stochastic control*. Translated from the French. Studies in Mathematics and its Applications 12. North-Holland Publishing Co., Amsterdam-New York, 1982.
- [2] H. Berestycki, On some nonlinear Sturm-Liouville problems. *J. Differential Equations* **26**, no. 3 (1977), 375–390.
- [3] L. Caffarelli, H. Berestycki and L. Nirenberg, Further qualitative properties for elliptic equations in unbounded domains. Dedicated to Ennio De Giorgi, *Ann. Scuola Norm. Sup. Pisa Cl. Sci.* **25**(1–2) (1997), 69–94.

- [4] H. Berestycki and L. Nirenberg, On the method of moving planes and the sliding method, *Boll. Soc. Brasil Mat. Nova ser.* **22** (1991), 237–275.
- [5] H. Berestycki, L. Nirenberg and S.R.S. Varadhan, The principal eigenvalue and maximum principle for second-order elliptic operators in general domains. *Comm. Pure Appl. Math.* **47** no. 1 (1994), 47–92.
- [6] J. Busca, M. Esteban and A. Quaas, Nonlinear eigenvalues and bifurcation problems for Pucci's operator, to appear in *Ann Inst. Henri Poincaré, Analyse non linéaire*.
- [7] X. Cabré and L.A. Caffarelli, *Fully Nonlinear Elliptic Equation*, American Mathematical Society, Colloquium Publication, Vol. 43, 1995.
- [8] L. Caffarelli, J.J. Kohn, L. Nirenberg and J. Spruck, The Dirichlet problem for nonlinear second order elliptic equations II, *Comm. Pure Appl. Math.* **38** (1985), 209–252.
- [9] L. Caffarelli, B. Gidas and J. Spruck, Asymptotic symmetry and local behavior of semilinear elliptic equations with critical Sobolev growth. *Comm. Pure Appl. Math.* **42** no. 3 (1989), 271–297.
- [10] C. Clemons and C. Jones, A geometric proof of Kwong-McLeod uniqueness result, *SIAM J. Math. Anal.* **24** (1993), 436–443.
- [11] M. Crandall, H. Ishi and P.L. Lions, *User's guide to viscosity solutions of second order partial differential equations*. Bulletin of the AMS, Vol 27, No 1, July 1992.
- [12] A. Cutri and F. Leoni, On the Liouville property for fully nonlinear equations. *Ann Inst. Henri Poincaré, Analyse non linéaire* **17** no. 2 (2000), 219–245.
- [13] E.N. Dancer, Some notes on the method of moving planes. *Bull. Austral. Math. Soc.* **46** (1992), 425–434.
- [14] D.G de Figueiredo, P.L. Lions and R.D. Nussbaum, A priori estimates and existence of positive solutions of semilinear elliptic equation. *J. Math. pures et appl.* **61** (1982), 41–63.
- [15] M. del Pino, M. Elgueta and R. Manásevich, A homotopic deformation along p of a Leray-Schauder degree result and existence for $(|u'|^{p-2}u')' + f(t, u) = 0$, $u(0) = u(T) = 0$, $p > 1$. *J. Differential Equations* **80** no. 1 (1989), 1–13.
- [16] M. del Pino and R. Manásevich, Global bifurcation from the eigenvalues of the p -Laplacian. *J. Differential Equations* **92** no. 2 (1991), 226–251.
- [17] P. Drábek, *Solvability and bifurcations of nonlinear equations*, Pitman Research Notes in Mathematics Series, 264. Longman Scientific and Technical, Harlow; copublished in the United States with John Wiley and Sons, Inc., New York, 1992.
- [18] M. Esteban, P. Felmer and A. Quaas, Large critical exponents for some second order uniformly elliptic operators. Preprint.
- [19] P. Felmer and A. Quaas, Critical Exponents for the Pucci's Extremal Operators, *C.R. Acad. Sci. Paris (I)* **335** (2002), 909–914.
- [20] P. Felmer and A. Quaas, On Critical exponents for the Pucci's extremal operators. *Ann Inst. Henri Poincaré, Analyse non linéaire* **20** no. 5 (2003), 843–865.
- [21] P. Felmer and A. Quaas, Positive solutions to 'semilinear' equation involving the Pucci's operator. *J. Differential Equations* **199** no. 2 (2004), 376–393.
- [22] P. Felmer, A. Quaas and M. Tang, On uniqueness for nonlinear elliptic equations involving the Pucci's extremal operators. Preprint.

- [23] B. Gidas and J. Spruck, Global and local behavior of positive solutions of nonlinear elliptic equations. *Comm. Pure Appl. Math.* **34** (1981), 525–598.
- [24] D. de Figueiredo and J.P. Gossez, On the first curve of the Fučík spectrum of an elliptic operator. *Differential Integral Equations* **7** no. 5-6 (1994), 1285–1302.
- [25] D. Gilbarg and N.S. Trudinger, *Elliptic partial differential equation of second order*, 2nd ed., Springer-verlag 1983.
- [26] L. Erbe and M. Tang, Structure of Positive Radial Solutions of Semilinear Elliptic Equation, *Journal of Differential Equations* **133** (1997), 179–202.
- [27] S. Fučík, *Solvability of nonlinear equations and boundary value problems*. With a foreword by Jean Mawhin. Mathematics and its Applications, **4**. D. Reidel Publishing Co. 1980.
- [28] T. Gallouet and O. Kavian, Résultats d'existence et de non-existence pour certains problèmes demi-linéaires à l'infini. (French. English summary) *Ann. Fac. Sci. Toulouse Math.* (5) **3** (1981), no. 3-4, 201–246 (1982)
- [29] R. Kajikiya, Existence and Asymptotic Behavior of nodal Solution for Semilinear Elliptic Equation. *Journal of Differential Equations* **106** (1993) 238–250.
- [30] M.K. Kwong, Uniqueness of positive solution of $\Delta u - u + u^p = 0$ in \mathbb{R}^N . *Arch. Rational Mech. Anal.* **105** (1989), 243–266.
- [31] M.K. Kwong, L. Zhang, Uniqueness of positive solution of $\Delta u + f(u) = 0$ in an annulus, *Differential Integral Equation* **4** (1991), 583–596.
- [32] D. Labutin, Isolated singularities for fully nonlinear elliptic equations. *J. Differential Equations* **177** no. 1 (2001), 49–76.
- [33] D. Labutin, Removable singularities for fully nonlinear elliptic equations. *Arch. Ration. Mech. Anal.* **155** no. 3 (2000), 201–214.
- [34] P.L. Lions, Bifurcation and optimal stochastic control, *Nonlinear Anal.* **2** (1983), 177–207.
- [35] P.L. Lions, Two remarks on Monge-Ampère equations, *Ann. Mat. Pura Appl.* **142** no. 4 (1985), 263–275.
- [36] P.L. Lions, On the existence of positive solutions of semilinear elliptic equations, *SIAM Review* **24** no. 4 (1982), 441–446.
- [37] P.L. Lions, Optimal control of diffusion processes and Hamilton-Jacobi-Bellman equations. I. The dynamic programming principle and applications. *Comm. Partial Differential Equations* **8** no. 10 (1983), 1101–1174.
- [38] P.L. Lions, Optimal control of diffusion processes and Hamilton-Jacobi-Bellman equations. II. Viscosity solutions and uniqueness. *Comm. Partial Differential Equations* **8** no. 11 (1983), 1229–1276.
- [39] P.L. Lions, Optimal control of diffusion processes and Hamilton-Jacobi-Bellman equations. III. Regularity of the optimal cost function. *Nonlinear partial differential equations and their applications. Collège de France seminar*, Vol. V (Paris, 1981/1982), 95–205.
- [40] W.M. Ni and R. Nussbaum. Uniqueness and nonuniqueness for positive radial solutions of $\Delta u + f(u, r) = 0$. *Comm. Pure Appl. Math.* **38** no. 1 (1985), 67–108.
- [41] C. Pucci, Operatori ellittici estremanti. *Ann. Mat. Pura Appl.* **72** (1966), 141–170.

- [42] C. Pucci, Maximum and minimum first eigenvalue for a class of elliptic operators. *Proc. Amer. Math. Soc.* **17** (1966), 788–795.
- [43] S.I. Pohozaev, Eigenfunctions of the equation $\Delta u + \lambda f(u) = 0$. *Soviet Math.* **5** (1965), 1408–1411.
- [44] A. Quaas, Existence of Positive Solutions to a 'semilinear' equation involving the Pucci's operator in a convex domain. *Diff. Integral Equations* **17** (2004), 481–494.
- [45] A. Quaas and B. Sirakov, Liouville Theorems for Pucci's Extremal Operator and Existences Results. Preprint.
- [46] P.H. Rabinowitz, Some aspects of nonlinear eigenvalue problems. *Rocky Mountain J. Math.* **74** no. 3 (1973), 161–202.
- [47] P.H. Rabinowitz, Some global results for nonlinear eigenvalue problems. *J. Funct. Anal.* **7** (1971), 487–513.
- [48] P.H. Rabinowitz, *Théorie du degré topologique et applications à des problèmes aux limites non linéaires*, Lectures Notes Lab. Analyse Numérique Université PARIS VI, 1975.
- [49] E. Rouy, First Semi-eigenvalue for nonlinear elliptic operator, preprint.
- [50] M. Schechter, The Fučík spectrum. *Indiana Univ. Math. J.* **43** no. 4 (1994), 1139–1157.

Patricio Felmer
Departamento de Ingeniería Matemática
and
Centro de Modelamiento Matemático
UMR2071 CNRS-UChile
Universidad de Chile
Casilla 170 Correo 3
Santiago
Chile

Alexander Quaas
Departamento de Matemática
Universidad Santa María Casilla
V-110, Avda. España 1680
Valparaíso
Chile

Principal Eigenvalue in an Unbounded Domain and a Weighted Poincaré Inequality

Jacqueline Fleckinger-Pellé, Jean-Pierre Gossez and François de
Thélin

A Djairo, avec toute notre amitié

Abstract. This paper is concerned with the existence of a positive principal eigenvalue for the p -laplacian on an unbounded domain Ω . The validity on Ω of a weighted Poincaré inequality is of particular importance in this study.

1. Introduction

This paper is mainly concerned with the existence of a positive principal eigenvalue (in short PPE) for the problem

$$-\Delta_p u = \lambda g(x)|u|^{p-2}u \text{ in } \Omega, \quad u = 0 \text{ on } \partial\Omega. \quad (1.1)$$

Here Ω is an unbounded smooth domain in \mathbb{R}^N , $\Delta_p u := \operatorname{div}(|\nabla u|^{p-2}\nabla u)$, $1 < p < \infty$, is the p -Laplacian, λ is the eigenvalue parameter and g is a weight function whose properties will be specified later. By a PPE we mean $\lambda > 0$ such that (1.1) admits a solution $u \not\equiv 0$, $u \geq 0$, in a suitable weak sense.

Several works have been devoted to this question in the last years. Let us first consider the case of low dimensions, i.e. $N \leq p$. It is known that for $p = 2$ and $\Omega = \mathbb{R}^N$ with $N = 1, 2$, a necessary condition for the existence of a PPE is that g changes sign and satisfies $\int_{\Omega} g \leq 0$ (cf. [6]); this result was partially extended to the p -laplacian case in [12]. Various sufficient conditions have been considered e.g. in [6], [12], [1], [2], [5], [9] for $\Omega = \mathbb{R}^N$, which all require the weight g to change sign and have a significantly large negative part at infinity. On the contrary, when Ω is bounded, the classical Poincaré inequality yields the existence of a PPE as soon as $g^+ \not\equiv 0$ (cf. e.g. [8]). One of our purposes in the present paper is to derive the existence of a PPE in some situations where Ω is unbounded and g is not necessarily negative at infinity (in fact g could even be positive in Ω , as in

Examples 3.5, 3.8 and 3.10 below). A key ingredient in our approach is the validity on Ω of a weighted Poincaré inequality of the form :

$$(P_m) \quad \int_{\Omega} m|u|^p \leq K(\Omega, m) \int_{\Omega} |\nabla u|^p \quad \forall u \in C_c^\infty(\Omega),$$

for some function $m \geq 0, \not\equiv 0$, suitably related to the weight g , and for some constant $K(\Omega, m)$.

Let us now consider the case of high dimensions, i.e. $N > p$. A necessary condition for the existence of a PPE can be found e.g. in [16] for $\Omega = \mathbb{R}^N$ and $g \geq 0$ at infinity, which shows that g must be sufficiently small at infinity. Most of the known sufficient conditions deal with $\Omega = \mathbb{R}^N$ and require either g^+ to lie in $L^{N/p}$ (cf. e.g. [2], [11], [9]) or the presence of some negative part for g at infinity which in a certain sense compensates the fact that g^+ would not lie in $L^{N/p}$ (cf. [1], [16]). In the present paper we are able to derive the existence of a PPE in some situations where Ω is unbounded, g^+ does not belong to $L^{N/p}$ and no negative part of g is present at infinity (in fact g could even be positive in Ω , as in Example 4.5 below). Here again our approach is partially based on a weighted Poincaré inequality of the form (P_m) .

Our paper is organized as follows. After some preliminaries in section 2, we consider successively the cases of low dimensions (section 3) and of high dimensions (section 4). The final section 5, which is independent from the previous ones, is concerned with questions of regularity, uniqueness and simplicity.

2. Preliminaries

It will be convenient to call “admissible” a nonnegative function q defined on Ω which satisfies the following local condition: for some exponent s , with $s = 1$ when $N < p$ and $s > N/p$ when $N \geq p$, one has

$$(H_0) \quad q \in L^s(\Omega_R) \text{ for all } R > 0.$$

Here Ω_R denotes $\Omega \cap B(0, R)$, and later we will denote $\Omega \setminus B(0, R)$ by Ω'_R . We will assume from now on that the open set Ω_R for $R > 0$ is smooth.

Associated with such a function q , we define, when $q \not\equiv 0$, the space W_q as the completion of $C_c^\infty(\Omega)$ with respect to the norm

$$\|u\|_{W_q} := \left(\int_{\Omega} |\nabla u|^p + \int_{\Omega} q|u|^p \right)^{1/p}.$$

The space $D^{1,p}(\Omega)$ will also be used when $N > p$, which is defined as the completion of $C_c^\infty(\Omega)$ with respect to the norm

$$\|u\|_{D^{1,p}} := \left(\int_{\Omega} |\nabla u|^p \right)^{1/p}.$$

When $N > p$, the well-known embedding $D^{1,p}(\Omega) \hookrightarrow L^{p^*}(\Omega)$, where p^* is the critical Sobolev exponent, implies $W_q \hookrightarrow W^{1,p}(\Omega_R)$ for all $R > 0$. Such a local imbedding still holds when $N \leq p$, as is easily deduced from the following

Lemma 2.1. *Suppose $N \leq p$ and q admissible, $q \not\equiv 0$. Then for any R sufficiently large (such that $q \not\equiv 0$ on Ω_R), there exists a constant K_R such that*

$$\int_{\Omega_R} |u|^p \leq K_R \left[\int_{\Omega_R} |\nabla u|^p + \int_{\Omega_R} q|u|^p \right] \quad \forall u \in C_c^\infty(\Omega). \tag{2.1}$$

Proof. Suppose (2.1) does not hold. Then there exists $R > 0$ with $q \not\equiv 0$ on Ω_R and a sequence $u_k \in C_c^\infty(\Omega)$ such that

$$\int_{\Omega_R} |u_k|^p > k \left[\int_{\Omega_R} |\nabla u_k|^p + \int_{\Omega_R} q|u_k|^p \right].$$

Write $v_k := u_k / \|u_k\|_{L^p(\Omega_R)}$. We have $\|v_k\|_{L^p(\Omega_R)} = 1$ and

$$\frac{1}{k} > \left[\int_{\Omega_R} |\nabla v_k|^p + \int_{\Omega_R} q|v_k|^p \right], \tag{2.2}$$

and so v_k remains bounded in $W^{1,p}(\Omega_R)$. It follows that for a subsequence, v_k converges weakly to v in $W^{1,p}(\Omega_R)$ and strongly to v in $L^r(\Omega_R)$, where $r = s'p \leq +\infty$. Moreover (2.2) implies $\nabla v = 0$ and so v is a constant, which is nonzero since $\|v\|_{L^p(\Omega_R)} = 1$. On the other hand one deduces from (2.2) that

$$0 = \lim_{k \rightarrow \infty} \int_{\Omega_R} q|v_k|^p = \int_{\Omega_R} q|v|^p,$$

which contradicts the fact that $q \not\equiv 0$ on Ω_R . □

Our weight g in (1.1) will be decomposed into $g = g_1 - g_2 + g_3$ with g_1, g_2, g_3 admissible functions. By a solution of (1.1) we mean $u \in W_{g_1+g_2+g_3}$ such that

$$\int_{\Omega} |\nabla u|^{p-2} \nabla u \nabla v = \lambda \int_{\Omega} g|u|^{p-2} uv \tag{2.3}$$

for all $v \in W_{g_1+g_2+g_3}$. Note that every term in (2.3) is well defined. Note also that in all the theorems of sections 3 and 4, the solution u will indeed lie in $W_{g_1+g_2+g_3}$ (or in a slightly smaller space).

3. Low dimensions

In this section we assume $N \leq p$. We will successively consider a weight g in (1.1) of the form $g = g_1, g = g_1 - g_2, g = g_1 - g_2 + g_3$.

The following assumption on g_1 will be used throughout this section. It associates to g_1 a function m for which the weighted Poincaré inequality (P_m) holds.

(H₁) There exists an admissible function m such that (P_m) holds and

$$g_1(x) \leq \theta(x)m(x) \text{ in } \Omega,$$

where the function θ verifies

$$\|\theta\|_{L^\infty(\Omega'_R)} \rightarrow 0 \text{ as } R \rightarrow \infty.$$

The inequality connecting g_1 and m in (H_1) above means, roughly speaking, that $g_1(x) = o(m(x))$ as $|x| \rightarrow \infty, x \in \Omega$. It implies $W_m \hookrightarrow W_{g_1}$.

Our first result concerns the case $g = g_1$.

Theorem 3.1. *Suppose $N \leq p$ and let $g = g_1$ with g_1 admissible, $g_1 \not\equiv 0$. Assume that g_1 satisfies (H_1) . Then (1.1) admits a PPE $\lambda_1(-\Delta_p, g_1)$, having an eigenfunction u in W_m (where m is provided by (H_1)).*

The proof of Theorem 3.1 uses the following

Lemma 3.2. *Under the hypotheses of Theorem 3.1, the mapping $u \rightarrow g_1^{1/p}u$ is compact from W_m into $L^p(\Omega)$.*

Proof. Let $u_k \rightharpoonup u$ in W_m . Splitting the integral over Ω into integrals over Ω_R and Ω'_R , one has

$$\int_{\Omega} g_1|u_k - u_l|^p \leq \|g_1\|_{L^s(\Omega_R)}\|u_k - u_l\|_{L^{ps'}(\Omega_R)}^p + \|\theta\|_{L^\infty(\Omega'_R)} \int_{\Omega'_R} m|u_k - u_l|^p.$$

Take $\varepsilon > 0$. By (H_1) for R sufficiently large, the second term above is less than $\varepsilon/2$, uniformly with respect to k, l . Fixing such a R and using Lemma 2.1 (for $q = m$) and the compact imbedding $W^{1,p}(\Omega_R) \hookrightarrow L^{ps'}(\Omega_R)$, one obtains that the first term is also less than $\varepsilon/2$ for k, l sufficiently large. The conclusion follows. \square

Proof of Theorem 3.1. Let us write

$$A_0 := \int_{\Omega} |\nabla u|^p, \quad B(u) := \int_{\Omega} g_1|u|^p.$$

We will first prove that A_0 is coercive on W_m . This clearly follows if, for some $\varepsilon > 0$,

$$\int_{\Omega} |\nabla u|^p \geq \varepsilon \left(\int_{\Omega} |\nabla u|^p + \int_{\Omega} m|u|^p \right) \quad \forall u \in W_m.$$

Using (P_m) , one sees that this inequality holds if

$$(1 - \varepsilon) \int_{\Omega} |\nabla u|^p \geq \varepsilon K(\Omega, m) \int_{\Omega} |\nabla u|^p \quad \forall u \in W_m.$$

But this last relation is obviously satisfied for ε sufficiently small. So A_0 is coercive on W_m . Using Lemma 3.2 one then concludes by standard arguments that the infimum of A_0 on $\{u \in W_m : B(u) = 1\}$ is achieved at some nonnegative function. By Lagrange multipliers rule, this infimum yields a PPE for (1.1). \square

We now turn to the case $g = g_1 - g_2$.

Theorem 3.3. *Suppose $N \leq p$ and let $g = g_1 - g_2$ with g_1, g_2 admissible. Assume that g_1 satisfies (H_1) . Assume also*

$$(H_2) \quad g_1 - g_2 > 0 \text{ a. e. on some nonempty open subset } \omega \subset \Omega.$$

Then (1.1) admits a PPE $\lambda_1(-\Delta_p, g_1 - g_2)$, having an eigenfunction u in W_{m+g_2} (where m is provided by (H_1)).

Proof. Let us write, for $\lambda > 0$,

$$A_\lambda(u) := \int_\Omega |\nabla u|^p + \lambda \int_\Omega g_2 |u|^p, \quad B(u) := \int_\Omega g_1 |u|^p$$

and

$$\rho(\lambda) := \inf\{A_\lambda(u) : u \in W_{m+g_2} \text{ and } B(u) = 1\}.$$

We will first prove that A_λ is coercive on W_{m+g_2} . As before this clearly follows if, for some $\varepsilon > 0$,

$$\int_\Omega |\nabla u|^p + \lambda \int_\Omega g_2 |u|^p \geq \varepsilon \left(\int_\Omega |\nabla u|^p + \int_\Omega m |u|^p + \int_\Omega g_2 |u|^p \right) \quad \forall u \in W_{m+g_2}.$$

Using (P_m) , one sees that this inequality holds if $\varepsilon < \lambda$ and

$$(1 - \varepsilon) \int_\Omega |\nabla u|^p \geq \varepsilon K(\Omega, m) \int_\Omega |\nabla u|^p \quad \forall u \in W_{m+g_2}.$$

But this last relation is obviously satisfied for ε sufficiently small. So A_λ is coercive on W_{m+g_2} for any $\lambda > 0$. Consequently, by minimization of A_λ on $\{u \in W_{m+g_2} : B(u) = 1\}$, using Lemma 3.2 (which implies that the mapping $u \rightarrow g_1^{1/p} u$ is compact from W_{m+g_2} into L^p), one deduces that for any $\lambda > 0$, the problem

$$-\Delta_p u + \lambda g_2 |u|^{p-2} u = \rho(\lambda) g_1 |u|^{p-2} u \text{ in } \Omega, \quad u = 0 \text{ on } \partial\Omega \tag{3.1}$$

has $\rho(\lambda)$ as PPE. We now aim at showing that $\rho(\lambda) = \lambda$ for some $\lambda > 0$, which will clearly yield the conclusion of Theorem 3.3. We have, for all $u \in W_{m+g_2}$ with $B(u) = 1$,

$$A_\lambda(u) \geq \lambda_1(-\Delta_p, g_1) \geq \lambda$$

provided $\lambda \leq \lambda_1(-\Delta_p, g_1)$, and consequently $\rho(\lambda) \geq \lambda$ for λ small. On the other hand take $u_0 \in W_{m+g_2}$ with $u_0 \not\equiv 0$ and support included in ω . For λ sufficiently large,

$$\int_\Omega |\nabla u_0|^p - \lambda \int_\Omega (g_1 - g_2) |u_0|^p < 0,$$

which implies $\rho(\lambda) < \lambda$ for those λ 's. But ρ is a concave u.s.c. function from \mathbb{R}_0^+ to \mathbb{R} (since it is the infimum of a family of affine functions), and so it is continuous on \mathbb{R}_0^+ (see e.g. Th. 10.1 in [14]). It follows that there exists λ such that $\rho(\lambda) = \lambda$, and the theorem is proved. \square

We finally turn to the case $g = g_1 - g_2 + g_3$.

Theorem 3.4. *Suppose $N \leq p$ and let $g = g_1 - g_2 + g_3$ with g_1, g_2 admissible and verifying $(H_1), (H_2)$. Assume g_3 of the form αm with*

$$(H_3) \quad 0 \leq \alpha < \frac{1}{\lambda_1(-\Delta_p, g_1 - g_2)K(\Omega, m)},$$

where m is provided by (H_1) , $\lambda_1(-\Delta_p, g_1 - g_2)$ is the PPE provided by Theorem 3.3, and $K(\Omega, m)$ is the constant appearing in (P_m) . Then Problem (1.1) admits a PPE $\lambda_1(-\Delta_p, g_1 - g_2 + \alpha m)$, having an eigenfunction in W_{m+g_2} .

Proof. The case $\alpha = 0$ corresponds to Theorem 3.3 and so we assume from now on $\alpha > 0$. Let us write, for $\lambda > 0$,

$$A_\lambda(u) := \int_\Omega |\nabla u|^p + \lambda \int_\Omega (g_2 - \alpha m)|u|^p, \quad B(u) := \int_\Omega g_1|u|^p$$

and

$$r(\lambda) := \inf\{A_\lambda(u) : u \in W_{m+g_2} \text{ and } B(u) = 1\}.$$

We start by investigating the values of λ for which A_λ is coercive on W_{m+g_2} . As before this coerciveness follows if, for some $\varepsilon > 0$,

$$\int_\Omega |\nabla u|^p + \lambda \int_\Omega (g_2 - \alpha m)|u|^p \geq \varepsilon \left(\int_\Omega |\nabla u|^p + \int_\Omega (g_2 + m)|u|^p \right) \quad \forall u \in W_{m+g_2}.$$

Using (P_m) one sees that this inequality holds if

$$(1 - \varepsilon) \int_\Omega |\nabla u|^p + (\lambda - \varepsilon) \int_\Omega g_2|u|^p \geq (\lambda\alpha + \varepsilon)K(\Omega, m) \int_\Omega |\nabla u|^p \quad \forall u \in W_{m+g_2}. \tag{3.2}$$

By choosing $\varepsilon < \lambda$ and ε small enough, one deduces that (3.2) can be verified provided $\lambda\alpha K(\Omega, m) < 1$, i.e. $\lambda \in \Lambda :=]0, \frac{1}{\alpha K(\Omega, m)}[$. So A_λ is coercive at least for $\lambda \in \Lambda$. It then follows, by standard minimization and application of the compactness Lemma 3.2, that for any such λ , the problem

$$-\Delta_p u + \lambda(g_2 - \alpha m)|u|^{p-2}u = r(\lambda)g_1|u|^{p-2}u \text{ in } \Omega, \quad u = 0 \text{ on } \partial\Omega \tag{3.3}$$

has $r(\lambda)$ as PPE. We aim at showing that $r(\lambda) = \lambda$ for some $\lambda \in \Lambda$, which will clearly yield the conclusion of Theorem 3.4. We have, for all $u \in W_{m+g_2}$ with $B(u) = 1$,

$$A_\lambda(u) \geq (1 - \alpha\lambda K(\Omega, m)) \int_\Omega |\nabla u|^p \geq (1 - \alpha\lambda K(\Omega, m))\lambda_1(-\Delta_p, g_1) > \lambda$$

for λ small enough. So $r(\lambda) \geq \lambda$ for λ small. On the other hand take a positive eigenfunction u_0 associated to $\lambda^* := \lambda_1(-\Delta_p, g_1 - g_2)$, as provided by Theorem 3.3. Note that by (H_3) , λ^* belongs to the range Λ of λ 's considered above. One has

$$\int_\Omega |\nabla u_0|^p - \lambda^* \int_\Omega (g_1 - g_2 + \alpha m)|u_0|^p = -\lambda^*\alpha \int_\Omega m|u_0|^p < 0$$

since $\int_{\Omega} m|u_0|^p > 0$ (indeed, if $\int_{\Omega} m|u_0|^p = 0$, then $mu_0 \equiv 0$ and so, by (H_1) , $g_1u_0 \equiv 0$, which is impossible since $\int_{\Omega} (g_1 - g_2)u_0 = 1$). This implies $r(\lambda^*) < \lambda^*$. Finally, as before, r is a concave u.s.c. function from Λ to \mathbb{R} and so is continuous on Λ . It follows that there exists $\lambda \in \Lambda$ such that $r(\lambda) = \lambda$. \square

We conclude this section with 3 examples. The first one leads for a certain class of weights to an almost necessary and sufficient condition for the existence of a PPE. The second one concerns a domain which is bounded in one direction, while the third one concerns a domain which is not bounded in any direction. In each of these examples, the weight is or can be taken positive all over Ω , which is of particular interest at the light of the necessary condition for $\Omega = \mathbb{R}^N$ mentioned in the introduction.

Example 3.5. Let $N = 1$, $p > 1$ and $\Omega =]0, +\infty[$. If m is admissible with $m \neq 0$ and satisfies

$$\int_0^\infty x^{p-1}m(x) dx < \infty, \tag{3.4}$$

then (P_m) holds. More precisely one has

$$\int_0^\infty m(x)|u(x)|^p dx \leq \left(\int_0^\infty x^{p-1}m(x)dx \right) \left(\int_0^\infty |u'(x)|^p dx \right) \tag{3.5}$$

for all $u \in C_c^\infty(\Omega)$. Indeed, writing $u(x) = \int_0^x u'(t)dt$, one has

$$|u(x)|^p \leq \left(\int_0^x dt \right)^{\frac{p}{p'}} \left(\int_0^x |u'(t)|^p dt \right) \leq x^{p-1} \int_0^\infty |u'(t)|^p dt,$$

and (3.5) follows easily. Consequently if g_1 is admissible, $\neq 0$, and satisfies (H_1) with respect to the above function m , then Theorem 3.1 applies and yields a PPE for the problem

$$-(|u'|^{p-2}u')' = \lambda g_1(x)|u|^{p-2}u \text{ in } \Omega, \quad u(0) = 0. \tag{3.6}$$

The following proposition describes a situation where (3.6) above does not admit a PPE.

Proposition 3.6. *Let g_1 be admissible such that for some $0 < \alpha < p - 1$,*

$$\int_0^\infty x^\alpha g_1(x) dx = +\infty. \tag{3.7}$$

Then (3.6) does not admit a PPE.

Proof. The idea is to estimate the Rayleigh quotient for some specific functions. Define for $R > 1$, $u_R(x)$ by $u_R(x) = x$ if $x \in [0, 1]$, $u_R(x) = x^{\alpha/p}$ if $x \in [1, R]$,

$u_R(x) = R^{\alpha/p} - R^{((\alpha/p)-1)}(x - R)$ if $r \in [R, 2R]$ and $u_R(x) = 0$ for $x \geq 2R$. We have

$$\begin{aligned} \int_0^\infty |u'_R(x)|^p dx &= 1 + \left(\frac{\alpha}{p}\right)^p \int_1^R x^{\alpha-p} dx + R^{\alpha-p} \int_R^{2R} dx \\ &= 1 + R^{\alpha+1-p} + \frac{1}{p-1-\alpha} \left(\frac{\alpha}{p}\right)^p (1 - R^{\alpha+1-p}) \end{aligned}$$

and so, since $R > 1$,

$$\int_0^\infty |u'_R(x)|^p dx \leq 2 + \left(\frac{\alpha}{p}\right)^p \left(\frac{1}{p-1-\alpha}\right).$$

On the other hand

$$\int_0^\infty g_1(x)|u_R(x)|^p dx \geq \int_1^R x^\alpha g_1(x) dx$$

whose limit as $R \rightarrow +\infty$ is $+\infty$ by (3.7). Assume now by contradiction the existence of a PPE λ for (3.6). One has, by Proposition 5.2 of the following section,

$$0 < \lambda \leq \left(\int_0^\infty |u'_R(x)|^p dx\right) / \left(\int_0^\infty g_1(x)|u_R(x)|^p dx\right).$$

Since the right hand side goes to 0 as $R \rightarrow +\infty$, a contradiction follows. □

Remark 3.7. Combining Example 3.5 and Proposition 3.6 in the particular case $g_1(x) = 1/(1+x)^\beta$, one gets an almost necessary and sufficient condition for the existence of a PPE. Indeed if $\beta < p$, then one can find α such that $\beta < 1 + \alpha < p$, and Proposition 3.6 yields non existence. On the contrary if $\beta > p$, then with $\varepsilon > 0$ such that $\beta - \varepsilon > p$, one has that $m(x) = 1/(1+x)^{\beta-\varepsilon}$ satisfies (3.4), and Example 3.5 yields existence.

Example 3.8. We consider here $N = 2$, $\Omega(l) = \mathbb{R} \times]-\pi/2l, +\pi/2l[$ with $l > 1$, and take $g = g_1 - g_2 + m$ where $g_1(x_1, x_2) = 2$ if $|x_1| < \pi/4$, $g_1(x_1, x_2) = 0$ if $|x_1| \geq \pi/4$, $g_2 \equiv 0$ and $m = l^2 - 1$. Note that since $l > 1$, the weight g is everywhere positive. We will see that Theorem 3.4 applies to this example if l is sufficiently close to 1. For this purpose we observe that the classical Poincaré inequality holds since $\Omega(l)$ is bounded in one direction. More precisely a simple calculation gives

$$\int_{\Omega(l)} |u|^p \leq \left(\frac{\pi}{l}\right)^p \int_{\Omega(l)} |\nabla u|^p \quad \forall u \in C_c^\infty(\Omega(l)),$$

and so the constant $K(\Omega(l), m)$ from (P_m) is $\leq (l^2 - 1)(\pi/l)^p$. Since g_1 has compact support hypothesis (H_1) clearly holds. Hypothesis (H_2) is also obvious. Finally fixing $l_0 > 1$, and taking $l \leq l_0$, one has $\lambda_1(-\Delta_p, g_1, \Omega(l)) \leq \lambda_1(-\Delta_p, g_1, \Omega(l_0))$, and hypothesis (H_3) is satisfied if $l \leq l_0$ and

$$\lambda_1(-\Delta_p, g_1, \Omega(l_0))(l^2 - 1)(\pi/l)^p < 1,$$

which clearly holds for l sufficiently close to 1. Theorem 3.4 thus applies.

Remark 3.9. When $p = 2$ a direct calculation shows that the problem of Example 3.8 has for any $l > 0$ a PPE. Indeed by putting $v(x_1) = \sqrt{2}e^{-\pi/4} \cos x_1$ for $|x_1| \leq \pi/4$, $v(x_1) = e^{-|x_1|}$ for $|x_1| > \pi/4$, and $u(x_1, x_2) = v(x_1) \cos lx_2$, one verifies that $-\Delta u = gu$ on Ω_l , $u = 0$ on $\partial\Omega_l$. This observation suggests that some room exists to improve Theorem 3.4.

Example 3.10. We consider here $N \leq p$,

$$\Omega = \{(x_1, x_2) \in \mathbb{R}^2 : -\log(2 + |x_1|) < x_2 < \log(2 + |x_1|)\}$$

and take $g = g_1$ with $g_1(x_1, x_2) = 1/(1 + |x_1|)^\varepsilon$ for some $\varepsilon > 0$. We claim that (P_m) is satisfied when $m(x_1, x_2) = 1/(\log(2 + |x_1|))^p$. Indeed, for $u \in C_c^\infty(\Omega)$ and $(x_1, x_2) \in \Omega$, one has

$$|u(x_1, x_2)|^p \leq \int_{-\log(2+|x_1|)}^{\log(2+|x_1|)} \left| \frac{\partial u}{\partial x_2}(x_1, s) \right|^p ds [2 \log(2 + |x_1|)]^{p/p'},$$

which leads to

$$\int_{-\log(2+|x_1|)}^{\log(2+|x_1|)} m(x_1, x_2) |u(x_1, x_2)|^p dx_2 \leq 2^p \int_{-\log(2+|x_1|)}^{\log(2+|x_1|)} \left| \frac{\partial u}{\partial x_2}(x_1, s) \right|^p ds;$$

integrating with respect to x_1 then gives (P_m) with $K(\Omega, m) = 2^p$. Using the behavior of the log function, one verifies that g_1 satisfies (H_1) with respect to m , and so Theorem 3.1 applies.

Remark 3.11. When $N \leq p$, an inequality of the form (P_m) with m admissible $\neq 0$ never holds for $\Omega = \mathbb{R}^N$. Assume indeed by contradiction that such an inequality holds. Then it a fortiori holds with m replaced by \tilde{m} where $\tilde{m} = m$ on a large ball B , $\tilde{m} = 0$ outside B , and B is chosen so that $m \neq 0$ on B ; it also holds for all $u \in W^{1,p}(\mathbb{R}^N)$ with compact support. Suppose for simplicity $\int_{\mathbb{R}^N} \tilde{m} = 1$.

We distinguish two cases: either (i) $p > N \geq 1$ or (ii) $p = N > 1$. In case (i), define u_k by $u_k(x) = 2$ for $|x| \leq k$, $u_k(x) = (-2/k)|x| + 4$ for $k \leq |x| \leq 2k$, and $u_k(x) = 0$ for $|x| \geq 2k$. A simple computation then leads to a contradiction. In case (ii), we adapt a construction from [4] and define u_k by $u_k(x) = 2$ for $|x| \leq k$, $u_k(x) = (3k - |x|)^{\delta_k}$ for $k \leq |x| \leq 3k$, and $u_k(x) = 0$ for $|x| \geq 3k$, where δ_k is chosen so that $(2k)^{\delta_k} = 2$. Note that $\delta_k \rightarrow 0$ as $k \rightarrow \infty$. Estimating $\int_{\mathbb{R}^N} |\nabla u_k|^N$ by splitting it into an integral over $\{x : k \leq |x| \leq 2k\}$ and an integral over $\{x : 2k \leq |x| \leq 3k\}$, one easily deduces a contradiction. Note that on the contrary, when $N > p$, an inequality of the form (P_m) may hold for $\Omega = \mathbb{R}^N$, as Example 4.5 below indicates.

4. High Dimensions

In this section we assume $N > p$. As in section 3, we will successively consider a weight g in (1.1) of the form $g = g_1$, $g = g_1 - g_2$, $g = g_1 - g_2 + g_3$.

Our first result is essentially well-known and concerns the case $g = g_1$.

Theorem 4.1. *Suppose $N > p$ and let $g = g_1$ with g_1 admissible, $g_1 \not\equiv 0$. Assume*

$$(H_4) \quad g_1 \in L^{N/p}(\Omega).$$

Then (1.1) admits a PPE $\lambda_1(-\Delta_p, g_1)$, having an eigenfunction u in $D^{1,p}(\Omega)$.

The proof of Theorem 4.1 uses the following

Lemma 4.2. *Under the hypothesis of Theorem 4.1, the mapping $u \rightarrow g_1^{1/p}u$ is compact from $D^{1,p}(\Omega)$ into $L^p(\Omega)$.*

Proof. Let $u_k \rightharpoonup u$ in $D^{1,p}(\Omega)$. Splitting the integral over Ω into integrals over Ω_R and Ω'_R , one has

$$\int_{\Omega} g_1 |u_k - u|^p \leq \|g_1\|_{L^s(\Omega_R)} \|u_k - u\|_{L^{ps'}(\Omega_R)}^p + \|g_1\|_{L^{N/p}(\Omega'_R)} \|u_k - u\|_{L^{p^*}(\Omega'_R)}^p.$$

Take $\varepsilon > 0$. One deduces from (H_4) and the imbedding $D^{1,p}(\Omega) \hookrightarrow L^{p^*}(\Omega)$ that for R sufficiently large, the second term of the right hand side above is less than $\varepsilon/2$, uniformly with respect to k and l . Fixing such a R , one deduces from the compact imbedding $W^{1,p}(\Omega_R) \hookrightarrow L^{ps'}(\Omega_R)$ that the first term becomes also less than $\varepsilon/2$ for k and l sufficiently large. \square

Proof of Theorem 4.1. Let us write

$$A_0(u) := \int_{\Omega} |\nabla u|^p, \quad B(u) := \int_{\Omega} g_1 |u|^p.$$

A_0 is obviously coercive on $D^{1,p}(\Omega)$. Applying Lemma 4.2, the result follows by minimization of A_0 on $\{u \in D^{1,p}(\Omega) : B(u) = 1\}$. \square

We now turn to the case $g = g_1 - g_2$.

Theorem 4.3. *Suppose $N > p$ and let $g = g_1 - g_2$ with g_1, g_2 admissible and satisfying (H_4) and (H_2) . Then (1.1) admits a PPE $\lambda_1(-\Delta_p, g_1 - g_2)$, having an eigenfunction u in W_{g_2} .*

Proof. Let us write, for $\lambda > 0$,

$$A_{\lambda}(u) := \int_{\Omega} |\nabla u|^p + \lambda \int_{\Omega} g_2 |u|^p, \quad B(u) := \int_{\Omega} g_1 |u|^p$$

and

$$\rho_{\lambda} := \inf\{A_{\lambda}(u) : u \in W_{g_2} \text{ and } B(u) = 1\}$$

Since A_{λ} is clearly coercive on W_{g_2} and since the mapping $u \rightarrow g_1^{1/p}u$ is compact from W_{g_2} into L^p , the problem

$$-\Delta_p u + \lambda g_2 |u|^{p-2} u = \rho(\lambda) g_1 |u|^{p-2} u \text{ in } \Omega, \quad u = 0 \text{ on } \partial\Omega \quad (4.1)$$

has $\rho(\lambda)$ as PPE. We aim at proving that $\rho(\lambda) = \lambda$ for some $\lambda > 0$, which will clearly imply the theorem. We have, for any $u \in W_{g_2}$ with $B(u) = 1$,

$$A_{\lambda}(u) \geq \lambda_1(-\Delta_p, g_1) \geq \lambda$$

provided $\lambda \leq \lambda_1(-\Delta_p, g_1)$, and so $\rho(\lambda) \geq \lambda$ for $\lambda > 0$ small. On the other hand consider $u_0 \not\equiv 0$ with support in the open set ω from (H_2) . For λ sufficiently large,

$$\int_{\Omega} |\nabla u_0|^p - \lambda \int_{\Omega} (g_1 - g_2)|u_0|^p < 0,$$

and so $\rho(\lambda) < \lambda$ for λ large. Since ρ is continuous, there exists λ such that $\rho(\lambda) = \lambda$. □

We finally turn to the case $g = g_1 - g_2 + g_3$ with $g_3 = \alpha m$.

Theorem 4.4. *Suppose $N > p$ and let $g = g_1 - g_2 + \alpha m$ with g_1, g_2, m admissible. Assume that (P_m) holds as well as (H_4) , (H_2) and (H_3) . Then (1.1) admits a PPE $\lambda_1(-\Delta_p, g_1 - g_2 + \alpha m)$, having an eigenfunction u in W_{m+g_2} .*

Note that in this theorem, g_1 and m are connected only through (H_3) , while in Theorem 3.4, g_1 and m were connected through (H_3) and (H_1) .

Proof of Theorem 4.4. The proof is totally analogous to that of Theorem 3.4. The only difference is the use of the compactness Lemma 4.2 instead of Lemma 3.2. One first gets, for a certain range of $\lambda > 0$, a PPE $r(\lambda)$ for (3.3), and one then looks for a fixed point of the mapping $\lambda \rightarrow r(\lambda)$. □

We conclude this section with an example where $\Omega = \mathbb{R}^N$, the weight is positive all over Ω and does not belong to $L^{N/p}$. This is of particular interest at the light of the comments made in the introduction.

Example 4.5. Take $N > p$, $\Omega = \mathbb{R}^N$ and $g = g_1 - g_2 + \alpha m$ with $g_1 \not\equiv 0$ admissible, $g_1 \in L^{N/p}(\Omega)$, $g_2 \equiv 0$ and $m(x) = 1/(1 + |x|^p)$. Observe that $m \notin L^{N/p}(\Omega)$. Denoting by $C_{N,p}$ the (inverse of the) Hardy constant (cf. e.g. [10], [13]), one has

$$\int_{\mathbb{R}^N} m|u|^p \leq \int_{\mathbb{R}^N} \frac{|u|^p}{|x|^p} \leq C_{N,p} \int_{\mathbb{R}^N} |\nabla u|^p \quad \forall u \in C_c^\infty(\Omega)$$

and so (H_3) is satisfied if

$$\alpha C_{N,p} \lambda_1(-\Delta_p, g_1) < 1.$$

Theorem 4.4 thus applies for these values of α .

5. Regularity and simplicity

The theorems of sections 3 and 4 give an eigenvalue $\lambda_1 > 0$ of (1.1), having an eigenfunction $u \not\equiv 0$, $u \geq 0$. Various properties of λ_1 and u are collected in the following

Theorem 5.1. *Assume $g = g_1 - g_2 + g_3$, with g_1, g_2, g_3 admissible. Let λ_1 be a PPE of (1.1), with $u \in W_{g_1+g_2+g_3}$, $u \not\equiv 0$, $u \geq 0$ an associated eigenfunction. Then (i) $u \in C_{loc}^\alpha(\Omega)$ for some $0 < \alpha < 1$ and $u > 0$ in Ω , (ii) λ_1 is the only PPE of (1.1) and any other positive eigenvalue is larger than λ_1 , (iii) λ_1 is simple.*

Proof. It follows from Lemma 2.1 (for $N \leq p$) or from the Sobolev imbeddings (for $N > p$) that for any $R > 0$, $u \in W^{1,p}(\Omega_R)$. One then deduces from Serrin estimates (cf. Th. 8 in [15]) that $u \in C_{loc}^\alpha(\Omega)$ for some $0 < \alpha < 1$. Moreover, since $u \geq 0$, $u \not\equiv 0$, it follows from Harnack inequality, arguing e.g. as in [7], that u is > 0 in Ω . Thus one has the conclusion of (i).

The uniqueness of the PPE follows by adapting an argument from [3], which is based on Picone identity. Indeed let $u \in W_{g_1+g_2+g_3}$ and let $v \in W_{g_1+g_2+g_3}$, $v > 0$, be an eigenfunction associated to PPE λ . Take a sequence $\varphi_k \in C_c^\infty(\Omega)$ which converges to u in $W_{g_1+g_2+g_3}$; by section 2, for a subsequence, φ_k and $\nabla\varphi_k$ converge a.e. in Ω to u and ∇u respectively. Using Picone identity and the fact that $|\varphi_k|^p/v^{p-1}$ is an admissible test function in the equation for v , one obtains

$$\begin{aligned} 0 &\leq \int_{\Omega} |\nabla\varphi_k|^p - |\nabla v|^{p-2} \nabla v \nabla \left(\frac{|\varphi_k|^p}{v^{p-1}} \right) \\ &= \int_{\Omega} |\nabla\varphi_k|^p - \lambda \int_{\Omega} g|v|^{p-2} v \frac{|\varphi_k|^p}{v^{p-1}}. \end{aligned}$$

Going to the limit as $k \rightarrow \infty$ yields

$$0 \leq \int_{\Omega} |\nabla u|^p - \lambda \int_{\Omega} g|u|^p. \tag{5.1}$$

Now if u is an eigenfunction associated to λ' , we deduce from (5.1)

$$0 \leq (\lambda' - \lambda) \int_{\Omega} g|u|^p,$$

which implies $\lambda \leq \lambda'$. At this stage one easily deduces statement (ii).

To derive (iii) one starts as above with $\lambda = \lambda' = \lambda_1$ and u, v . With φ_k as above one has, using Fatou’s lemma,

$$\begin{aligned} 0 &\leq \int_{\Omega_0} \lim L(\varphi_k, v) \leq \liminf \int_{\Omega} L(\varphi_k, v) \\ &= \liminf \int_{\Omega} R(\varphi_k, v) \end{aligned} \tag{5.2}$$

where Ω_0 is any compact subdomain of Ω and where L and R are the usual expressions appearing in Picone identity (cf. [3]):

$$\begin{aligned} L(u, v) &= |\nabla u|^p + (p-1) \frac{u^p}{v^p} |\nabla v|^p - p \frac{u^{p-1}}{v^{p-1}} |\nabla v|^{p-2} \nabla v \nabla u, \\ R(u, v) &= |\nabla u|^p - \nabla \left(\frac{u^p}{v^{p-1}} \right) |\nabla v|^{p-2} \nabla v. \end{aligned}$$

But the argument used above to prove (ii) shows that the right hand side of (5.2) is zero. We thus have

$$0 \leq \int_{\Omega_0} L(u, v) = 0$$

for any Ω_0 . The equality case of Picone identity then implies $\nabla(u/v) = 0$ a.e. in Ω , and a classical result on Sobolev spaces (cf. e.g. Corollary 2.1.9 in [17]) yields that u is a multiple of v . \square

In the course of the above proof, one has obtained the following

Proposition 5.2. *Assume as before $g = g_1 + g_2 + g_3$ with g_1, g_2, g_3 admissible, and let λ be a PPE. Then*

$$\lambda \int_{\Omega} g|u|^p \leq \int_{\Omega} |\nabla u|^p$$

for all $u \in W_{g_1+g_2+g_3}$.

This proposition shows that the eigenpairs constructed in sections 3 and 4 through fixed point arguments in fact minimize the Rayleigh quotient.

References

- [1] W. Allegretto, Principal eigenvalues for indefinite weight elliptic problems in \mathbb{R}^N , *Proc. Amer. Math. Soc.* **116** (1992), 701–706.
- [2] W. Allegretto and Y.X. Huang, Eigenvalues of the indefinite-weight p -Laplacian in weighted spaces, *Funkc. Ekvac.* **8** (1995), 233–242.
- [3] W. Allegretto and Y.X. Huang, A Picone's identity for the p -Laplacian and applications, *Nonlinear Anal. TMA* **32** (1998), 819–830.
- [4] M. Arias, J. Campos and J.-P. Gossez, On the antimaximum principle and the Fučík spectrum for the Neumann p -Laplacian, *Diff. Int. Equations* **13** (2000), 217–226.
- [5] K.J. Brown, D. Daners and J. Lopez-Gomez, Change of stability for Schrödinger semigroups, *Proc. Royal Soc. Edinburgh* **125** A (1995), 827–846.
- [6] K.J. Brown, C. Cosner and J. Fleckinger, Principal eigenvalues for problems with indefinite weight function on \mathbb{R}^N , *Proc. Amer. Math. Soc.* **109** (1990), 147–155.
- [7] M. Cuesta, Eigenvalue problems for the p -Laplacian with indefinite weights, *Electr. J.D.E.* **33** (2001), 1–9.
- [8] D. de Figueiredo, Positive solutions of semilinear elliptic equations, *Lect. Notes Math.* **957** (1982), 34–87.
- [9] J. Fleckinger, J.-P. Gossez and F. de Thélin, Antimaximum principles in \mathbb{R}^N : local versus global, *J. Diff. Equat.* **196** (2004), 119–133.
- [10] J. Fleckinger, E. Harrell and F. de Thélin, Asymptotic behavior of solutions for some nonlinear partial differential equations in unbounded domains, *Electr. J.D.E.* **77** (2001), 1–14.
- [11] J. Fleckinger, R. Manasevich, N. Stavrakakis and F. de Thélin, Principal eigenvalues for some quasilinear elliptic equations on \mathbb{R}^N , *Adv. Diff. Equat.* **2** (1997), 981–1003.
- [12] Y. Huang, Eigenvalues of the p -Laplacian in \mathbb{R}^N with indefinite weight, *Comm. Math. Univ. Carolinae* **36** (1995), 519–527.
- [13] N. Okazawa, L^p theory of Schrödinger operator with strongly singular potential, *Japanese J. Math.* **22** (1996), 199–239.
- [14] R.T. Rockafellar, *Convex Analysis*, Princeton University Press, 1970.

- [15] J.B. Serrin, Local behavior of solutions of quasi-linear equations, *Acta Math.* **111** (1964), 247–302.
- [16] N. Stavrakakis and F. de Thélin, Principal eigenvalues and antimaximum principle for some quasilinear elliptic equations on \mathbb{R}^N , *Math. Nachr.* **212** (2000), 155–171.
- [17] W. Ziemer, *Weakly differentiable functions*, Springer, 1989.

Jacqueline Fleckinger-Pellé
MIP et CEREMATH
Université des Sciences Sociales
21 Allée de Brienne
31042 Toulouse Cedex
France
e-mail: jfleck@univ-tlse1.fr

Jean-Pierre Gossez
Département de Mathématique, C. P. 214
Université Libre de Bruxelles
1050 Bruxelles
Belgium
e-mail: gossez@ulb.ac.be

François de Thélin
UMR MIP et UFR MIG
Université Paul Sabatier
118, route de Narbonne
31062 Toulouse Cedex 4
France
e-mail: dethelin@mip.ups-tlse.fr

Uniform Stabilization for a Hyperbolic Equation with Acoustic Boundary Conditions in Simple Connected Domains

Cícero L. Frota and Nikolai A. Larkin¹

Dedicated to Professor Djairo Guedes de Figueiredo on the occasion of his 70th birthday

Abstract. We prove the existence and uniqueness of strong and weak solutions as well as the uniform stabilization of the energy of initial boundary value problem for a hyperbolic equation in a class of domains $\Omega \subset \mathbb{R}^n$ which includes simply connected regions. The boundary Γ of Ω can be a smooth simple connected manifold and the boundary conditions are acoustic boundary conditions on a portion Γ_1 of the boundary and the Dirichlet boundary condition on the rest of Γ .

1. Introduction

Let Ω be a bounded domain in \mathbb{R}^n , $n \geq 1$ with a boundary Γ of class C^2 . Assume that Γ consists of two disjoint pieces, Γ_0, Γ_1 , each having nonempty interior. Let ν be the unit normal vector pointing towards the exterior of Ω . In this paper we study global solvability and the uniform decay of the energy for the following boundary value problem

$$u_{tt}(x, t) - \Delta u(x, t) + \alpha(x)u(x, t) = 0, \quad x \in \Omega, \quad t > 0; \quad (1.1)$$

$$u(x, t) = 0, \quad x \in \Gamma_0, \quad t > 0; \quad (1.2)$$

$$u_t(x, t) + f(x)z_t(x, t) + g(x)z(x, t) = 0, \quad x \in \Gamma_1, \quad t > 0; \quad (1.3)$$

$$\frac{\partial u}{\partial \nu}(x, t) = h(x)z_t(x, t), \quad x \in \Gamma_1, \quad t > 0; \quad (1.4)$$

$$u(x, 0) = u_0(x), \quad u_t(x, 0) = u_1(x), \quad x \in \Omega; \quad (1.5)$$

$$z_t(x, 0) = \frac{1}{h(x)} \left(\frac{\partial u_0}{\partial \nu}(x) \right), \quad x \in \Gamma_1; \quad (1.6)$$

¹Partially supported by research grant from CNPq-Brazil.

where $\Delta = \sum_{i=1}^n \frac{\partial^2}{\partial x_i^2}$, $\alpha : \Omega \rightarrow \mathbb{R}$ and $f, g, h : \bar{\Gamma}_1 \rightarrow \mathbb{R}$ are given functions. We have no restrictions for a sign of α , but $|\alpha|$ must be sufficiently small to ensure the stability result.

Boundary conditions (1.3) and (1.4) are called acoustic boundary conditions introduced in a more general form, which had the presence of z_{tt} in (1.3), by J. T. Beale and S. I. Rosencrans. In [4] they considered a linear wave equation and proved that when the term z_{tt} was included in (1.3) there was no uniform rate of decay of the energy associated. See also [5, 6]. Nonlinear wave equations with acoustic boundary conditions were studied in [8, 10]. Similar boundary conditions were considered in [3] where the authors proved that the presence of the second derivative z_{tt} in acoustic boundary conditions made the solution to blow up.

The uniform stabilization of hyperbolic problems with a nonlinear feedback on a portion of the boundary was studied by several authors imposing strong geometrical hypothesis on Ω which excluded domains having a smooth connected boundary or simply connected regions, for instance [1, 2, 7, 13, 15, 16]. The usual assumptions in these cases were Γ_0, Γ_1 being closed and disjoint or $\bar{\Gamma}_0 \cap \bar{\Gamma}_1 = \emptyset$. On the other hand, in [12] the uniform stabilization was proved also for simply connected domains but with restriction on the dimension $n, n \leq 3$, (see also [13]). Recently, in [9], the existence, uniqueness and uniform stabilization of global solutions for a generalized system of Klein-Gordon type equations with acoustic boundary conditions on a portion of the boundary were proved. In this case, also was assumed that $\bar{\Gamma}_0 \cap \bar{\Gamma}_1 = \emptyset$.

In this work we define a class of acoustic boundary conditions, (1.3) and (1.4), which ensures the uniform decay of the energy and is slightly different from those used in [4, 8, 10]:

$$u_t + m(x)z_{tt} + f(x)z_t + g(x)z = 0, \quad x \in \Gamma_1, t > 0; \tag{1.7}$$

$$\frac{\partial u}{\partial \nu} = z_t, \quad x \in \Gamma_1, t > 0. \tag{1.8}$$

As far as (1.8) corresponds to the case of a nonporous boundary, (1.4) simulates a porous boundary when a function h is nonnegative. Equation (1.3) does not contain the second derivative, mz_{tt} , which physically means that the material of the surface is much more lighter than a liquid flowing along it. It was observed that porous walls of channels or airfoils stabilize hydrodynamic flows, [3]. Here we use this idea and consider a variable porosity of walls: they are porous on the dissipative (Γ_1) part of the boundary and impermeable on the rest of it.

The absence of the second derivative z_{tt} in (1.3) brings difficulties in studying solvability of our problem because it can be rewritten as the following operator equation

$$BU_t + AU = F, \tag{1.9}$$

where $B \neq I$ and A are some operators in different Hilbert spaces. It is not simple to apply the semigroups theory as well as Galerkin's procedure because a system

of corresponding ordinary equations is not normal and one can not apply directly the Caratheodory's theorem. To overcome this difficulty, we consider (1.3) as a degenerated second order equation

$$u'_\epsilon + \epsilon z''_\epsilon + f(x)z'_\epsilon + g(x)z_\epsilon = 0, \quad \text{on } \Gamma_1 \times (0, \infty); \tag{1.10}$$

where $\epsilon \rightarrow 0$. For every $\epsilon > 0$ we have a problem similar to those studied in [4, 8, 10]. It means that we can exploit their results on solvability of the perturbed problem and then pass to the limit as $\epsilon \rightarrow 0$. Once we have regular (strong) solutions, using density and compactness arguments we can get the weak solvability.

We prove global solvability of (1.1)-(1.6) for all $n \in \mathbb{N}^*$ and uniform stabilization for $1 \leq n \leq 3$. The paper is organized as follows: in Section 2 we give necessary notations, the results on existence and uniqueness of strong and weak solutions are given in Section 3 and the uniform stabilization is proved in Section 4.

2. Notations

We denote respectively the inner products and the norms in $L^2(\Omega)$ and $L^2(\Gamma_1)$ by

$$(u, v) = \int_{\Omega} u(x) v(x) dx, \quad |u| = \left(\int_{\Omega} (u(x))^2 dx \right)^{\frac{1}{2}},$$

$$(\varphi, \psi)_{\Gamma_1} = \int_{\Gamma_1} \varphi(x) \psi(x) d\Gamma, \quad |\varphi|_{\Gamma_1} = \left(\int_{\Gamma_1} (\varphi(x))^2 d\Gamma \right)^{\frac{1}{2}}.$$

Let $H(\Delta, \Omega) = \{u \in H^1(\Omega); \Delta u \in L^2(\Omega)\}$ be the Hilbert space with the norm

$$\|u\|_{H(\Delta, \Omega)} = \left(\|u\|_{H^1(\Omega)}^2 + |\Delta u|^2 \right)^{\frac{1}{2}},$$

where $H^1(\Omega)$ is the real Sobolev space of the first order. Denoting $\gamma_0 : H^1(\Omega) \rightarrow H^{\frac{1}{2}}(\Gamma)$ and $\gamma_1 : H(\Delta, \Omega) \rightarrow H^{-\frac{1}{2}}(\Gamma)$ the trace map of order zero and the Neumann trace map on $H(\Delta, \Omega)$, respectively, we have

$$\gamma_0(u) = u|_{\Gamma} \quad \text{and} \quad \gamma_1(u) = \left(\frac{\partial u}{\partial \nu} \right)|_{\Gamma} \quad \text{for all } u \in \mathcal{D}(\overline{\Omega}).$$

We denote by V the closure in $H^1(\Omega)$ of $\{u \in C^1(\overline{\Omega}); u = 0 \text{ on } \Gamma_0\}$. Since Γ_0 has nonempty interior and Ω is a regular domain, then $V = \{u \in H^1(\Omega); \gamma_0(u) = 0 \text{ on } \Gamma_0\}$ is a closed subspace of $H^1(\Omega)$; the Poincaré inequality holds on V , i.e. there exists a constant $C_p > 0$ such that

$$|u|^2 \leq C_p \sum_{i=1}^n \int_{\Omega} \left(\frac{\partial u}{\partial x_i}(x) \right)^2 dx, \quad \text{for all } u \in V. \tag{2.1}$$

In view of this inequality, we define in V the inner product and the norm by

$$((u, v)) = \sum_{i=1}^n \int_{\Omega} \frac{\partial u}{\partial x_i}(x) \frac{\partial v}{\partial x_i}(x) dx, \quad \|u\| = \left(\sum_{i=1}^n \int_{\Omega} \left(\frac{\partial u}{\partial x_i}(x) \right)^2 dx \right)^{\frac{1}{2}}$$

which are equivalent to the usual inner product and the norm in $H^1(\Omega)$.

Because $H^{\frac{1}{2}}(\Gamma) \hookrightarrow L^2(\Gamma)$ and $\gamma_0 : H^1(\Omega) \rightarrow H^{\frac{1}{2}}(\Gamma)$ is a continuous function, there exists a constant $C_{\gamma} > 0$ such that

$$|\gamma_0(u)|_{\Gamma_1}^2 \leq C_{\gamma} \|u\|^2 \text{ for all } u \in V, \tag{2.2}$$

For the usual functional spaces we use the standard notation as in [14].

3. Existence results

Assume that

(A.1) $f, g \in C(\overline{\Gamma}_1)$; $f(x) > 0, g(x) > 0$ for all $x \in \overline{\Gamma}_1$.

(A.2) $h \in C(\overline{\Gamma}_1)$; $h(x) > 0$ for all $x \in \Gamma_1, h(x) = 0$ for all $x \in (\overline{\Gamma}_1 \cap \overline{\Gamma}_0)$.

(A.3) $\alpha \in L^{\infty}(\Omega)$.

We have the following result on the existence and uniqueness of strong solution to (1.1)–(1.6).

Theorem 3.1. *Suppose (A.1)–(A.3) hold. Let $u_0 \in (V \cap H^2(\Omega))$ satisfy the inequality*

$$\left| \frac{\gamma_1(u_0)(x)}{h(x)} \right| < C_0 \text{ for all } x \in \Gamma_1 \tag{3.1}$$

and $u_1 \in V$. Then there exists a unique pair of functions (u, z) which is a solution to the problem (1.1)–(1.6) from the class

$$u, u_t \in L^{\infty}_{loc}(0, \infty; V), \quad u(t) \in H(\Delta, \Omega) \text{ a.e. on } [0, \infty), \tag{3.2}$$

$$u_{tt} \in L^{\infty}_{loc}(0, \infty; L^2(\Omega)), \tag{3.3}$$

$$h^{\frac{1}{2}}z, \quad h^{\frac{1}{2}}z_t, \quad h^{\frac{1}{2}}z_{tt} \in L^2_{loc}(0, \infty; L^2(\Gamma_1)). \tag{3.4}$$

Proof. Let $\{\omega_j\}_{j \in \mathbb{N}}$ and $\{\xi_j\}_{j \in \mathbb{N}}$ be orthonormal bases of V and $L^2(\Gamma_1)$, respectively. For each $\epsilon \in (0, 1)$ and $k \in \mathbb{N}$ we consider

$$u_{\epsilon k}(x, t) = \sum_{j=1}^k a_{jk}(t) \omega_j(x), \quad x \in \Omega, \quad t \in [0, T_k]; \tag{3.5}$$

$$z_{\epsilon k}(x, t) = \sum_{j=1}^k b_{jk}(t) \xi_j(x), \quad x \in \Gamma_1, \quad t \in [0, T_k]; \tag{3.6}$$

local solutions to the approximate perturbed problem

$$\left(u''_{\epsilon k}(t) + \nabla u_{\epsilon k}(t) + \alpha u_{\epsilon k}(t), \omega_j\right) - \left(hz'_{\epsilon k}(t), \gamma_0(\omega_j)\right)_{\Gamma_1} = 0, \quad 1 \leq j \leq k; \quad (3.7)$$

$$\epsilon \left(z''_{\epsilon k}(t), \xi_j\right)_{\Gamma_1} + \left(h[\gamma_0(u'_{\epsilon k}(t)) + fz'_{\epsilon k}(t) + gz_{\epsilon k}(t)], \xi_j\right)_{\Gamma_1} = 0, \quad 1 \leq j \leq k; \quad (3.8)$$

$$u_{\epsilon k}(0) = u_{0k} = \sum_{j=1}^k (u_0, \omega_j) \omega_j, \quad u'_{\epsilon k}(0) = u_{1k} \sum_{j=1}^k (u_1, \omega_j) \omega_j; \quad (3.9)$$

$$z_{\epsilon k}(0) = -\left(\frac{u_{1k} + fz'_{\epsilon k}(0)}{g}\right), \quad z'_{\epsilon k}(0) = \sum_{j=1}^k \left(\frac{1}{h} \gamma_1(u_0), \xi_j\right) \xi_j \quad (3.10)$$

Since (3.7)–(3.10) is a normal system of ordinary differential equations the local existence of regular functions $(a_{jk})_{1 \leq j \leq k}$ and $(b_{jk})_{1 \leq j \leq k}$ is standard. A solution (u, z) to the problem (1.1)–(1.6) will be obtained as the limit (diagonal process) of $(u_{\epsilon k}, z_{\epsilon k})$ as $k \rightarrow \infty$ and $\epsilon \rightarrow 0$. Therefore we need estimates uniform on $k \in \mathbb{N}$ and $\epsilon > 0$. From (3.7) and (3.8) we have the approximate equations

$$\left(u''_{\epsilon k}(t) + \nabla u_{\epsilon k}(t) + \alpha u_{\epsilon k}(t), \omega\right) - \left(hz'_{\epsilon k}(t), \gamma_0(\omega)\right)_{\Gamma_1} = 0, \quad (3.11)$$

$$\epsilon \left(z''_{\epsilon k}(t), \xi\right)_{\Gamma_1} + \left(h[\gamma_0(u'_{\epsilon k}(t)) + fz'_{\epsilon k}(t) + gz_{\epsilon k}(t)], \xi\right)_{\Gamma_1} = 0, \quad (3.12)$$

which hold for all $\omega \in \text{Span}\{\omega_1, \dots, \omega_k\}$ and $\xi \in \text{Span}\{\xi_1, \dots, \xi_k\}$.

Estimate 1. Taking $\omega = 2u'_{\epsilon k}(t)$ and $\xi = 2z'_{\epsilon k}(t)$ in (3.11) and (3.12) respectively, we have

$$\begin{aligned} & \frac{d}{dt} \left[|u'_{\epsilon k}(t)|^2 + \|u_{\epsilon k}(t)\|^2 + \epsilon |z'_{\epsilon k}(t)|^2_{\Gamma_1} + \int_{\Gamma_1} h(x)g(x)(z_{\epsilon k}(x, t))^2 d\Gamma \right] \\ & + 2 \int_{\Gamma_1} h(x)f(x)(z'_{\epsilon k}(x, t))^2 d\Gamma = -2(\alpha u_{\epsilon k}(t), u'_{\epsilon k}(t)) \\ & \leq (1 + C_p) \|\alpha\|_{L^\infty(\Omega)} (|u'_{\epsilon k}(t)|^2 + \|u_{\epsilon k}(t)\|^2). \end{aligned}$$

Integrating this from 0 to t and taking into account that $0 < \epsilon < 1$ and (3.1), we get

$$\begin{aligned} & |u'_{\epsilon k}(t)|^2 + \|u_{\epsilon k}(t)\|^2 + \epsilon |z'_{\epsilon k}(t)|^2_{\Gamma_1} + \int_{\Gamma_1} h(x)g(x)(z_{\epsilon k}(x, t))^2 d\Gamma \\ & + 2 \int_0^t \int_{\Gamma_1} h(x)f(x)(z'_{\epsilon k}(x, \tau))^2 d\Gamma d\tau \\ & \leq |u_1|^2 + \|u_0\|^2 + \epsilon |z'_{\epsilon k}(0)|^2 + (\max_{x \in \overline{\Gamma_1}} |h(x)g(x)|) |z_{\epsilon k}(0)|^2_{\Gamma_1} \\ & + (1 + C_p) \|\alpha\|_{L^\infty(\Omega)} \int_0^t (|u'_{\epsilon k}(\tau)|^2 + \|u_{\epsilon k}(\tau)\|^2) d\tau \end{aligned}$$

$$\leq C_1 + (1 + C_p)\|\alpha\|_{L^\infty(\Omega)} \int_0^t (|u'_{\epsilon k}(\tau)|^2 + \|u_{\epsilon k}(\tau)\|^2) d\tau.$$

Because

$$0 < \min_{x \in \Gamma_1} f(x) = f_0 \text{ and } 0 < \min_{x \in \Gamma_1} g(x) = g_0,$$

the last inequality yields

$$\begin{aligned} & |u'_{\epsilon k}(t)|^2 + \|u_{\epsilon k}(t)\|^2 + |h^{\frac{1}{2}}z_{\epsilon k}(t)|_{\Gamma_1}^2 + \int_0^t |h^{\frac{1}{2}}z'_{\epsilon k}(\tau)|_{\Gamma_1}^2 d\tau \\ & \leq \frac{C_1}{C_2} + \frac{(1 + C_p)}{C_2}\|\alpha\|_{L^\infty(\Omega)} \int_0^t (|u'_{\epsilon k}(\tau)|^2 + \|u_{\epsilon k}(\tau)\|^2) d\tau, \end{aligned} \tag{3.13}$$

where $C_2 = \min\{1, 2f_0, g_0\}$. Let $T > 0$ be arbitrarily fixed. Then the Gronwall inequality and (3.13) give

$$|u'_{\epsilon k}(t)|^2 + \|u_{\epsilon k}(t)\|^2 + |h^{\frac{1}{2}}z_{\epsilon k}(t)|_{\Gamma_1}^2 + \int_0^t |h^{\frac{1}{2}}z'_{\epsilon k}(\tau)|_{\Gamma_1}^2 d\tau \leq C_3, \tag{3.14}$$

where $C_3 = \frac{C_1}{C_2} \exp\left(\frac{(1 + C_p)\|\alpha\|_{L^\infty(\Omega)} T}{C_2}\right)$ does not depend on k, ϵ and t . This estimate allows us to extend the local solution $(u_{\epsilon k}, z_{\epsilon k})$ to the whole interval $[0, T]$.

Estimate 2. From (3.7)–(3.10), for all $k \in \mathbb{N}$ and $\epsilon \in (0, 1)$, we have

$$|u''_{\epsilon k}(0)| \leq \left(|\Delta u_0| + \|\alpha\|_{L^\infty(\Omega)} |u_0| \right) = C_4 \text{ and } |z''_{\epsilon k}(0)| = 0. \tag{3.15}$$

Differentiating (3.11) and (3.12) by t , and then taking $\omega = 2u''_{\epsilon k}(t)$ and $\xi = 2z''_{\epsilon}(t)$, we obtain

$$\begin{aligned} & \frac{d}{dt} \left[|u''_{\epsilon k}(t)|^2 + \|u'_{\epsilon k}(t)\|^2 + \epsilon |z''_{\epsilon k}(t)|_{\Gamma_1}^2 + \int_{\Gamma_1} g(x)(h^{\frac{1}{2}}(x)z'_{\epsilon k}(x, t))^2 d\Gamma \right] \\ & + 2 \int_{\Gamma_1} f(x)(h^{\frac{1}{2}}(x)z''_{\epsilon k}(x, t))^2 d\Gamma = -2(\alpha u'_{\epsilon k}(t), u''_{\epsilon k}(t)) \\ & \leq (1 + C_p\|\alpha\|_{L^\infty(\Omega)}) (|u''_{\epsilon k}(t)|^2 + \|u'_{\epsilon k}(t)\|^2). \end{aligned}$$

Integrating this from 0 to t and using (3.1) and (3.15), we find

$$\begin{aligned} & |u''_{\epsilon k}(t)|^2 + \|u'_{\epsilon k}(t)\|^2 + \epsilon |z''_{\epsilon k}(t)|^2_{\Gamma_1} + \int_{\Gamma_1} g(x)(h^{\frac{1}{2}}(x)z'_{\epsilon k}(x, t))^2 d\Gamma \\ & + 2 \int_0^t \int_{\Gamma_1} f(x)(h^{\frac{1}{2}}(x)z''_{\epsilon k}(x, \tau))^2 d\Gamma d\tau \leq C_5 \\ & + (1 + C_p \|\alpha\|_{L^\infty(\Omega)}) \int_0^t (|u''_{\epsilon k}(\tau)|^2 + \|u'_{\epsilon k}(\tau)\|^2) d\tau. \end{aligned}$$

Therefore we obtain

$$\begin{aligned} & |u''_{\epsilon k}(t)|^2 + \|u'_{\epsilon k}(t)\|^2 + \epsilon |z''_{\epsilon k}(t)|^2_{\Gamma_1} + \int_{\Gamma_1} (h^{\frac{1}{2}}(x)z'_{\epsilon k}(x, t))^2 d\Gamma \\ & + 2 \int_0^t \int_{\Gamma_1} (h^{\frac{1}{2}}(x)z''_{\epsilon k}(x, \tau))^2 d\Gamma d\tau \leq \frac{C_5}{C_2} \\ & + \left(\frac{1 + C_p \|\alpha\|_{L^\infty(\Omega)}}{C_2} \right) \int_0^t (|u''_{\epsilon k}(\tau)|^2 + \|u'_{\epsilon k}(\tau)\|^2) d\tau. \end{aligned}$$

This and Gronwall's inequality yield the estimate 2:

$$\begin{aligned} & |u''_{\epsilon k}(t)|^2 + \|u'_{\epsilon k}(t)\|^2 + \epsilon |z''_{\epsilon k}(t)|^2_{\Gamma_1} + |h^{\frac{1}{2}}z'_{\epsilon k}(t)|^2_{\Gamma_1} \\ & + \int_0^t |h^{\frac{1}{2}}z''_{\epsilon k}(\tau)|^2_{\Gamma_1} d\tau \leq C_6, \end{aligned} \tag{3.16}$$

where $C_6 = \frac{C_5}{C_2} \exp\left(\frac{(1 + C_p \|\alpha\|_{L^\infty(\Omega)})T}{C_2}\right)$ does not depend on k , ϵ and t .

From (3.14) and (3.16), we have:

$$\begin{aligned} & (u_{\epsilon k})_{\substack{\epsilon \in (0,1) \\ k \in \mathbb{N}}} \text{ and } (u'_{\epsilon k})_{\substack{\epsilon \in (0,1) \\ k \in \mathbb{N}}} \text{ are bounded in } L^\infty(0, T; V), \\ & (u''_{\epsilon k})_{\substack{\epsilon \in (0,1) \\ k \in \mathbb{N}}} \text{ is bounded in } L^\infty(0, T; L^2(\Omega)), \\ & (h^{\frac{1}{2}}z_{\epsilon k})_{\substack{\epsilon \in (0,1) \\ k \in \mathbb{N}}} \text{ and } (h^{\frac{1}{2}}z'_{\epsilon k})_{\substack{\epsilon \in (0,1) \\ k \in \mathbb{N}}} \text{ are bounded in } L^\infty(0, T; L^2(\Gamma_1)), \\ & (h^{\frac{1}{2}}z''_{\epsilon k})_{\substack{\epsilon \in (0,1) \\ k \in \mathbb{N}}} \text{ is bounded in } L^2(0, T; L^2(\Gamma_1)), \\ & \lim_{\substack{k \rightarrow \infty \\ \epsilon \rightarrow 0}} \epsilon |z''_{\epsilon k}(t)|_{\Gamma_1} = 0 \quad \text{a.e. in } [0, T]. \end{aligned}$$

Using compactness arguments, we can pass to the limit as $k \rightarrow \infty$ and $\epsilon \rightarrow 0$ to prove the existence of solutions to (1.1)-(1.6) satisfying (3.2)-(3.4). Uniqueness can be proved in a standard way and we omit it. □

Now we define weak solutions to (1.1)–(1.6).

Definition 3.1. A pair (u, z) , where $u : \Omega \times (0, \infty) \rightarrow \mathbb{R}$ and $z : \Gamma_1 \times (0, \infty) \rightarrow \mathbb{R}$, is a weak solution to (1.1)–(1.6) if

$$u \in L^\infty_{\text{loc}}(0, \infty; V), \quad u' \in L^\infty_{\text{loc}}(0, \infty; L^2(\Omega)), \quad h^{\frac{1}{2}}z, h^{\frac{1}{2}}z' \in L^2_{\text{loc}}(0, \infty; L^2(\Gamma_1))$$

and for all $v \in V$ and $T > 0$ arbitrarily fixed

$$\frac{d}{dt}(u'(t), v) + ((u(t), v)) - (hz(t), \gamma_0(v))_{\Gamma_1} + (\alpha u(t), v) = 0, \text{ in } \mathcal{D}'(0, T);$$

$$\frac{d}{dt}(h\gamma_0(u(t)), e)_{\Gamma_1} + (h[fz'(t) + gz(t)], e)_{\Gamma_1} = 0, \text{ in } \mathcal{D}'(0, T);$$

$$u(0) = u_0 \quad , \quad u'(0) = u_1 .$$

Using Theorem 3.1, density and compactness arguments, it is easy to prove

Theorem 3.2. *Suppose (A.1)–(A.3) hold. Let $u_0 \in V$ satisfy*

$$\left\| \frac{\gamma_1(u_0)}{h} \right\|_{H^{-\frac{1}{2}}(\Gamma_1)} < \overline{C}_0 \tag{3.17}$$

and $u_1 \in L^2(\Omega)$. Then there exists a unique pair of functions (u, z) which is a weak solution to the problem (1.1)–(1.6).

4. Uniform decay

In this section we choose a suitable partition (Γ_0, Γ_1) of Γ and a special function h such that for initial data u_0, u_1 as in Theorem 3.2, the energy associated to the problem (1.1)–(1.6)

$$E(t) = |u'(t)|^2 + \|u(t)\|^2 + \int_{\Gamma_1} g(x) h(x) (z(x, t))^2 d\Gamma, \text{ for all } t \geq 0 \tag{4.1}$$

tends to zero exponentially as $t \rightarrow \infty$.

For this purpose we prove the exponential decay of the energy when (u, z) is a strong solution to (1.1)–(1.6), given by Theorem 3.1. Using density arguments the exponential decay of the energy for weak solutions can be proved.

The hypothesis (A.3) on the function α is not sufficient and we need additional one. We also note that in this section $1 \leq n \leq 3$, and we consider domains Ω having connected boundaries.

Let us fix a point $x^0 \in \mathbb{R}^n$ and set

$$m(x) = x - x^0, \quad x \in \mathbb{R}^n, \tag{4.2}$$

$$\Gamma_0 = \{x \in \Gamma \text{ such that } \langle m(x) \cdot \nu(x) \rangle \leq 0\}, \tag{4.3}$$

$$\Gamma_1 = \{x \in \Gamma \text{ such that } \langle m(x) \cdot \nu(x) \rangle > 0\}. \tag{4.4}$$

Here $\langle m(x) \cdot \nu(x) \rangle = \sum_{j=1}^n m_j(x) \nu_j(x)$ is the inner product in \mathbb{R}^n .

We denote

$$M = \max_{1 \leq i \leq n} (\max_{x \in \bar{\Omega}} |m_j(x)|) \tag{4.5}$$

and consider $h : \bar{\Gamma}_1 \rightarrow \mathbb{R}$ given by

$$h(x) = \beta(x) \langle m(x) \cdot \nu(x) \rangle, \tag{4.6}$$

where

$$\beta \in C^1(\bar{\Gamma}_1) \text{ satisfies } 0 < \beta_0 \leq \beta(x) \text{ for all } x \in \bar{\Gamma}_1. \tag{4.7}$$

We note that h defined by (4.6) satisfies (A.2).

Theorem 4.1. *Let all the assumptions of Theorem 3.1 be satisfied and let the pair (u, z) be a unique solution to (1.1)–(1.6). Additionally, suppose that h is given by (4.6), $1 \leq n \leq 3$, and α satisfies*

$$\|\alpha\|_{L^\infty(\Omega)} < \min\left\{ \frac{1}{M(1 + C_p) + C_p(n - 1)}, \frac{1}{C_p} \right\}. \tag{4.8}$$

Then there exist positive constants ϱ and θ such that

$$E(t) \leq \varrho e^{-\theta t} \text{ for all } t > 0. \tag{4.9}$$

Proof. Multiplying (1.1) by $2u'$ and integrating over Ω , we get

$$\frac{d}{dt} |u'(t)|^2 - 2(\Delta u(t), u'(t)) + \frac{d}{dt} \int_{\Omega} \alpha(x)(u(x, t))^2 dx = 0. \tag{4.10}$$

Taking into account (1.3), (1.4), (4.3) and (4.4), we can see that

$$\begin{aligned} & -2(\Delta u(t), u'(t)) \\ &= \frac{d}{dt} \|u(t)\|^2 + 2 \int_{\Gamma_1} f(x)h(x)(z'(x, t))^2 d\Gamma + \frac{d}{dt} \int_{\Gamma_1} g(x)h(x)(z(x, t))^2 d\Gamma. \end{aligned}$$

Therefore (4.10) can be rewritten as

$$\begin{aligned} & \frac{d}{dt} \left[|u'(t)|^2 + \|u(t)\|^2 + \int_{\Omega} \alpha(x)(u(x, t))^2 dx + \int_{\Gamma_1} g(x)h(x)(z(x, t))^2 d\Gamma \right] \\ &= -2 \int_{\Gamma_1} f(x)h(x)(z'(x, t))^2 d\Gamma. \end{aligned} \tag{4.11}$$

In order to obtain a direct connection with the problem (1.1)–(1.6), we introduce the perturbed energy

$$E_1(t) = E(t) + \int_{\Omega} \alpha(x)(u(x, t))^2 dx, \text{ for all } t \geq 0. \tag{4.12}$$

By (4.11)

$$E'_1(t) = -2 \int_{\Gamma_1} f(x)h(x)(z'(x, t))^2 d\Gamma. \tag{4.13}$$

From Poincaré’s inequality, (4.1), (4.12) and (A.3) we have

$$\begin{aligned} -\|\alpha\|_{L^\infty(\Omega)}C_pE(t) &\leq -\|\alpha\|_{L^\infty(\Omega)}C_p\|u(t)\|^2 \\ &\leq -\|\alpha\|_{L^\infty(\Omega)}|u(t)|^2 \leq \int_{\Omega} \alpha(x)(u(x,t))^2 dx \\ &= E_1(t) - E(t) \end{aligned}$$

which yields

$$(1 - \|\alpha\|_{L^\infty(\Omega)}C_p)E(t) \leq E_1(t), \tag{4.14}$$

where $(1 - \|\alpha\|_{L^\infty(\Omega)}C_p) > 0$, since (4.8) holds. Moreover, from (4.12), (4.1) we obtain

$$\begin{aligned} E_1(t) &\leq |u'(t)|^2 + (1 + \|\alpha\|_{L^\infty(\Omega)}C_p)\|u(t)\|^2 + \int_{\Gamma_1} g(x)h(x)(z(x,t))^2 d\Gamma \\ &\leq (1 + \|\alpha\|_{L^\infty(\Omega)}C_p)E(t). \end{aligned} \tag{4.15}$$

Therefore, taking into account (4.14) and (4.15), we have that the energies E and E_1 are equivalent.

Now we consider a perturbation of E_1 . For each $\epsilon > 0$ we define

$$E_{1\epsilon}(t) = E_1(t) + \epsilon \rho(t), \text{ for all } t \geq 0, \tag{4.16}$$

where

$$\begin{aligned} \rho(t) &= 2 \int_{\Omega} \left[\langle m(x) \cdot \nabla u(x,t) \rangle u'(x,t) + \frac{(n-1)}{2} u(x,t)u'(x,t) \right] dx \\ &+ \int_{\Gamma_1} \left(2g(x)\langle m(x) \cdot \nu(x) \rangle + h(x) \right) \left(u(x,t)z(x,t) + \frac{f(x)}{2}(z(x,t))^2 \right) d\Gamma. \end{aligned} \tag{4.17}$$

We omit the variables x and t of the functions under the integrals in order to simplify the notations. Making use of (2.1), (2.2) and (4.6), we estimate

$$\left| 2 \int_{\Omega} \langle m \cdot \nabla u \rangle u' dx \right| \leq M \left(\|u(t)\|^2 + |u'(t)|^2 \right); \tag{4.18}$$

$$\left| (n-1) \int_{\Omega} uu' dx \right| \leq \frac{(n-1)C_p}{2} \|u(t)\|^2 + \frac{(n-1)}{2} |u'(t)|^2; \tag{4.19}$$

$$\begin{aligned} \left| \int_{\Gamma_1} 2g\langle m \cdot \nu \rangle uz d\Gamma \right| &= \left| \int_{\Gamma_1} \frac{2gh}{\beta} uz d\Gamma \right| \leq \frac{\|g\|_{C(\bar{\Gamma}_1)}}{\beta_0} \int_{\Gamma_1} 2|h^{\frac{1}{2}}||u||h^{\frac{1}{2}}||z| d\Gamma \\ &+ \left(\frac{\|g\|_{C(\bar{\Gamma}_1)}\|h\|_{C(\bar{\Gamma}_1)}C_\gamma}{\beta_0} \right) \|u(t)\|^2 + \frac{\|g\|_{C(\bar{\Gamma}_1)}}{\beta_0} \int_{\Gamma_1} h z^2 d\Gamma; \end{aligned} \tag{4.20}$$

$$\left| \int_{\Gamma_1} huz \, d\Gamma \right| \leq \left(\frac{\|h\|_{C(\bar{\Gamma}_1)} C_\gamma}{2} \right) \|u(t)\|^2 + \frac{1}{2} \int_{\Gamma_1} hz^2 \, d\Gamma. \tag{4.21}$$

Analogously

$$\left| \int_{\Gamma_1} \left(\frac{2g\langle m \cdot \nu \rangle + h}{2} \right) fz^2 \, d\Gamma \right| \leq \left(\frac{\|g\|_{C(\bar{\Gamma}_1)} \|f\|_{C(\bar{\Gamma}_1)}}{\beta_0} + \frac{\|f\|_{C(\bar{\Gamma}_1)}}{2} \right) \int_{\Gamma_1} hz^2 \, d\Gamma. \tag{4.22}$$

Using (4.16)–(4.21) we find a positive constant C_1 such that

$$|\rho(t)| \leq C_1 \left(|u'(t)|^2 + \|u(t)\|^2 + \int_{\Gamma_1} hz^2 \, d\Gamma \right). \tag{4.23}$$

We know that

$$\int_{\Gamma_1} hz^2 \, d\Gamma \leq \frac{1}{g_0} \int_{\Gamma_1} ghz^2 \, d\Gamma,$$

therefore (4.23) takes the form

$$|\rho(t)| \leq C_2 \left(|u'(t)|^2 + \|u(t)\|^2 + \int_{\Gamma_1} ghz^2 \, d\Gamma \right), \tag{4.24}$$

where $C_2 = \max\{C_1, \frac{C_1}{g_0}\}$. We can see that

$$\begin{aligned} - \int_{\Omega} \alpha u^2 dx &= - \int_{\Omega} (\alpha^+ - \alpha^-) u^2 dx \leq \int_{\Omega} \alpha^- u^2 dx \leq \|\alpha\|_{L^\infty(\Omega)} C_p \|u(t)\|^2 \\ &\leq \|\alpha\|_{L^\infty(\Omega)} C_p E(t) \leq C_3 E_1(t), \end{aligned} \tag{4.25}$$

where in the last inequality we have used the equivalence of E and E_1 .

Combining (4.24) and (4.25), we find a positive constant C_4 such that

$$|\rho(t)| \leq C_4 E_1(t) \quad \text{for all } t \geq 0. \tag{4.26}$$

Now (4.16) and (4.26) imply

$$\frac{1}{\epsilon} |E_{1\epsilon}(t) - E_1(t)| \leq C_4 E_1(t) \quad \text{for all } t \geq 0.$$

This means that there exist positive constants C_5 and C_6 such that

$$C_5 E_1(t) \leq E_{1\epsilon}(t) \leq C_6 E_1(t) \quad \text{for all } t \geq 0$$

which proves that the energies E_1 and $E_{1\epsilon}$ are also equivalent.

On the other hand, differentiating $E_{1\epsilon}$ defined by (4.16), we have

$$E'_{1\epsilon}(t) = E'_1(t) + \epsilon \rho'(t), \tag{4.27}$$

where

$$\begin{aligned} \rho'(t) = & 2 \int_{\Omega} [\langle m \cdot \nabla u' \rangle u' + \langle m \cdot \nabla u \rangle \Delta u - \alpha \langle m \cdot \nabla u \rangle u] dx + (n - 1) | u'(t) |^2 \\ & + (n - 1) \int_{\Omega} (u \Delta u - \alpha u^2) dx + \frac{d}{dt} \left[\int_{\Gamma_1} (2g \langle m \cdot \nu \rangle + h) (uz + \frac{f}{2} z^2) d\Gamma \right]. \end{aligned} \tag{4.28}$$

Next we analyse the terms on the right hand side of (4.28). Because

$$\int_{\Gamma_0} \langle m \cdot \nu \rangle \left(\frac{\partial u}{\partial \nu} \right)^2 d\Gamma \leq 0,$$

we can see that

$$2 \int_{\Omega} \langle m \cdot \nabla u' \rangle u' dx \leq -n | u'(t) |^2 + \int_{\Gamma_1} \langle m \cdot \nu \rangle (u')^2 d\Gamma; \tag{4.29}$$

and since $1 \leq n \leq 3$, following the ideas of [12] (Lemma 2.2) and [11], we find

$$2 \int_{\Omega} \langle m \cdot \nabla u \rangle \Delta u dx \leq (n - 2) \|u(t)\|^2 + 2 \int_{\Gamma_1} \langle m \cdot \nabla u \rangle h z' d\Gamma - \int_{\Gamma_1} \langle m \cdot \nu \rangle \| \nabla u \|_{\mathbb{R}^n}^2 d\Gamma. \tag{4.30}$$

Moreover,

$$-2 \int_{\Omega} \alpha \langle m \cdot \nabla u \rangle u dx \leq \| \alpha \|_{L^\infty(\Omega)} M(1 + C_p) \|u(t)\|^2; \tag{4.31}$$

$$(n - 1) \int_{\Omega} u \Delta u dx = -(n - 1) \|u(t)\|^2 + (n - 1) \int_{\Gamma_1} h u z' d\Gamma; \tag{4.32}$$

$$-(n - 1) \int_{\Omega} \alpha u^2 dx \leq (n - 1) \| \alpha \|_{L^\infty(\Omega)} C_p \|u(t)\|^2. \tag{4.33}$$

Taking into account (4.13), (4.27)–(4.33), we obtain

$$\begin{aligned} E'_{1\epsilon}(t) \leq & \epsilon \left\{ - | u'(t) |^2 + \left[\| \alpha \|_{L^\infty(\Omega)} \left(M(1 + C_p) + C_p(n - 1) \right) - 1 \right] \|u(t)\|^2 \right. \\ & + \int_{\Gamma_1} \left[(n - 1) h u z' + 2 \langle m \cdot \nabla u \rangle h z' + \langle m \cdot \nu \rangle (u')^2 - \langle m \cdot \nu \rangle \| \nabla u \|_{\mathbb{R}^n}^2 \right] d\Gamma \\ & \left. + \frac{d}{dt} \left[\int_{\Gamma_1} (2g \langle m \cdot \nu \rangle + h) (uz + \frac{f}{2} z^2) d\Gamma \right] \right\} - 2 \int_{\Gamma_1} f h (z')^2 d\Gamma. \end{aligned} \tag{4.34}$$

Using (4.8), we can see that

$$-C_7 = \left[\| \alpha \|_{L^\infty(\Omega)} \left(M(1 + C_p) + C_p(n - 1) \right) - 1 \right] < 0, \tag{4.35}$$

then (4.34) and (4.35) yield

$$E'_{1\epsilon}(t) \leq -C_8\epsilon E(t) - 2 \int_{\Gamma_1} fh(z')^2 d\Gamma + \epsilon \left\{ \frac{d}{dt} \left[\int_{\Gamma_1} (2g\langle m \cdot \nu \rangle + h) (uz + \frac{f}{2} z^2) d\Gamma \right] \right. \\ \left. + \int_{\Gamma_1} \left[(n-1)huz' + 2\langle m \cdot \nabla u \rangle hz' + \langle m \cdot \nu \rangle (u')^2 + ghz^2 - \langle m \cdot \nu \rangle \|\nabla u\|_{\mathbb{R}^n}^2 \right] d\Gamma \right\},$$

where $C_8 = \min\{1, C_7\}$. This and the equivalence of E and E_1 imply

$$E'_{1\epsilon}(t) \leq -C_9\epsilon E_1(t) - 2 \int_{\Gamma_1} fh(z')^2 d\Gamma + \epsilon \left\{ \frac{d}{dt} \left[\int_{\Gamma_1} (2g\langle m \cdot \nu \rangle + h) (uz + \frac{f}{2} z^2) d\Gamma \right] \right. \\ \left. + \int_{\Gamma_1} \left[(n-1)huz' + 2\langle m \cdot \nabla u \rangle hz' + \langle m \cdot \nu \rangle (u')^2 + ghz^2 - \langle m \cdot \nu \rangle \|\nabla u\|_{\mathbb{R}^n}^2 \right] d\Gamma \right\}. \tag{4.36}$$

We estimate separate terms in the right-hand side of (4.36) as follows:

$$\int_{\Gamma_1} \left[\langle m \cdot \nu \rangle (u')^2 + ghz^2 \right] d\Gamma \leq \int_{\Gamma_1} \left[2 \left(\langle m \cdot \nu \rangle f^2(z')^2 + \langle m \cdot \nu \rangle g^2 z^2 \right) + ghz^2 \right] d\Gamma \\ = 2 \int_{\Gamma_1} \langle m \cdot \nu \rangle f^2(z')^2 d\Gamma + \int_{\Gamma_1} (2g\langle m \cdot \nu \rangle + h)gz^2 d\Gamma = 2 \int_{\Gamma_1} \langle m \cdot \nu \rangle f^2(z')^2 d\Gamma \\ - \frac{d}{dt} \left[\int_{\Gamma_1} (2g\langle m \cdot \nu \rangle + h) (uz + \frac{f}{2} z^2) d\Gamma \right] + \int_{\Gamma_1} (2g\langle m \cdot \nu \rangle + h)uz' d\Gamma \tag{4.37}$$

and

$$2 \int_{\Gamma_1} \langle m \cdot \nabla u \rangle hz' d\Gamma \leq 2M \int_{\Gamma_1} \|\nabla u\|_{\mathbb{R}^n} h |z'| d\Gamma \leq M \int_{\Gamma_1} (\lambda h \|\nabla u\|_{\mathbb{R}^n}^2 + \frac{h}{\lambda} |z'|^2) d\Gamma,$$

where λ is an arbitrary positive number. The last inequality, (4.36) and (4.37) imply

$$E'_{1\epsilon}(t) \leq -C_9\epsilon E_1(t) - \int_{\Gamma_1} \left(2f - \frac{\epsilon M}{\lambda} \right) h(z')^2 d\Gamma \\ + \epsilon \left\{ \int_{\Gamma_1} (2g\langle m \cdot \nu \rangle + nh)uz' d\Gamma + 2 \int_{\Gamma_1} \langle m \cdot \nu \rangle f^2(z')^2 d\Gamma - \int_{\Gamma_1} (\langle m \cdot \nu \rangle - M\lambda h) \|\nabla u\|_{\mathbb{R}^n}^2 d\Gamma \right\}. \tag{4.38}$$

Denoting

$$M_1 = \max_{x \in \Gamma_1} (2g\langle m \cdot \nu \rangle + nh),$$

we obtain for all $\lambda > 0$, using (2.2), (4.7), the equivalence of E and E_1

$$\begin{aligned} \int_{\Gamma_1} (2g\langle m \cdot \nu \rangle + nh) uz' d\Gamma &\leq \int_{\Gamma_1} (2g\langle m \cdot \nu \rangle + nh) \left(\lambda u^2 + \frac{1}{4\lambda} (z')^2 \right) d\Gamma \\ &\leq M_1 \lambda C E(t) + \frac{1}{4\lambda} \int_{\Gamma_1} (2g\langle m \cdot \nu \rangle + nh) (z')^2 d\Gamma \\ &\leq \frac{M_1 \lambda C}{(1 - \|\alpha\|_{L^\infty(\Omega)} C_p)} E_1(t) + \frac{1}{4\lambda} \int_{\Gamma_1} (2g\langle m \cdot \nu \rangle + nh) (z')^2 d\Gamma, \end{aligned}$$

From this and (4.38)

$$\begin{aligned} E'_{1\epsilon}(t) &\leq -C_9 \epsilon E_1(t) + \frac{M_1 C \epsilon \lambda}{(1 - \|\alpha\|_{L^\infty(\Omega)} C_p)} E_1(t) - \epsilon \int_{\Gamma_1} (\langle m \cdot \nu \rangle - M \lambda h) \|\nabla u\|_{\mathbb{R}^n}^2 d\Gamma \\ &\quad - 2 \int_{\Gamma_1} \left[\left(f - \frac{\epsilon M}{2\lambda} \right) h - \epsilon \left(\langle m \cdot \nu \rangle f^2 + \frac{g}{4\lambda} \langle m \cdot \nu \rangle + \frac{nh}{8\lambda} \right) \right] (z')^2 d\Gamma. \end{aligned}$$

Taking into account (4.6), (4.7), we have

$$\begin{aligned} E'_{1\epsilon}(t) &\leq -\epsilon \left(C_9 - \frac{M_1 C \lambda}{(1 - \|\alpha\|_{L^\infty(\Omega)} C_p)} \right) E_1(t) - \epsilon \int_{\Gamma_1} \langle m \cdot \nu \rangle \left(1 - M \beta \lambda \right) \|\nabla u\|_{\mathbb{R}^n}^2 d\Gamma \\ &\quad - \int_{\Gamma_1} \langle m \cdot \nu \rangle \left[2f\beta - \epsilon \left(2f^2 + \frac{g}{2\lambda} + \frac{n\beta}{4\lambda} + \frac{M\beta}{\lambda} \right) \right] (z')^2 d\Gamma. \quad (4.39) \end{aligned}$$

Choosing in (4.39) $\lambda > 0$ such that

$$C_{10} = \left(C_9 - \frac{M_1 C \lambda}{(1 - \|\alpha\|_{L^\infty(\Omega)} C_p)} \right) > 0 \quad \text{and} \quad (1 - M \beta \lambda) > 0,$$

we conclude that

$$E'_{1\epsilon}(t) \leq -\epsilon C_{10} E_1(t) - \int_{\Gamma_1} \langle m \cdot \nu \rangle \left[2f\beta - \epsilon \left(\frac{8\lambda f^2 + 2g + n\beta + 4M\beta}{4\lambda} \right) \right] (z')^2 d\Gamma.$$

Now choosing $\epsilon > 0$ such that

$$\epsilon < \frac{8\lambda f(x)\beta(x)}{8\lambda f^2(x) + 2g(x) + n\beta(x) + 4M\beta(x)}, \quad \text{for all } x \in \bar{\Gamma}_1,$$

we obtain

$$E'_{1\epsilon}(t) \leq -\epsilon C_{10} E_1(t).$$

This and the equivalence between the energies E , $E_{1\epsilon}$, and E_1 prove (4.9). The proof of Theorem 4.1 is completed. \square

As we said in the beginning of this section, using Theorem 4.1, density and compactness arguments we can prove the following theorem:

Theorem 4.2. *Assume that all the assumptions of Theorem 3.2 are satisfied and let the pair (u, z) be a unique weak solution to (1.1)–(1.6). Additionally, suppose that h is given by (4.5), $1 \leq n \leq 3$, and α satisfies (4.8). Then there exist positive constants δ and μ such that*

$$E(t) \leq \delta e^{-\mu t} \quad \text{for all } t > 0. \quad (4.40)$$

References

- [1] M. Aassila, M. M. Cavalcanti and V. N. Domingos Cavalcanti, Existence and uniform decay of the wave equation with nonlinear boundary damping and boundary memory source term, *Calc. Var.* **15** (2002), 155–180.
- [2] F. Alabau-Boussouira, Convexity and weighted integral inequalities for energy decay rates of nonlinear dissipative hyperbolic systems, *Appl. Math. and Optimization* **51** (2005), 61–105.
- [3] H. D. Alber and J. Cooper, Quasilinear hyperbolic 2×2 systems with a free damping boundary condition, *Journal für die reine und angewandte Mathematik* **406** (1990), 10–43.
- [4] J. T. Beale, Spectral properties of an acoustic boundary condition, *Indiana Univ. Math. J.* **25** (1976), 895–917.
- [5] J. T. Beale, Acoustic scattering from locally reacting surfaces, *Indiana Univ. Math. J.* **26** (1977), 199–222.
- [6] J. T. Beale and S. I. Rosencrans, Acoustic boundary conditions, *Bull. Amer. Math. Soc.* **80** (1974), 1276–1278.
- [7] G. Chen, A note on the boundary stabilization of the wave equation, *SIAM J. Control and Opt.* **19** (1981), 106–113.
- [8] A. T. Cousin, C. L. Frota and N. A. Larkin, Global solvability and asymptotic behavior of hyperbolic problem with acoustic boundary conditions, *Funkcial. Ekvac.* **44** (2001), 471–485.
- [9] A. T. Cousin, C. L. Frota and N. A. Larkin, On a system of Klein-Gordon type equations with acoustic boundary conditions, *J. Math. Anal. Appl.* **293** (2004), 293–309.
- [10] C. L. Frota and J. A. Goldstein, Some nonlinear wave equations with acoustic boundary conditions, *J. Diff. Eqs.* **164** (2000), 92–109.
- [11] P. Grisvard, Contrôlabilité exacte avec conditions mêlées, *C. R. Acad. Sci. Paris* **305**, Serie I (1997), 363–366.
- [12] V. Komornik and E. Zuazua, A direct method for boundary stabilization of the wave equation, *J. Math. Pures et Appl.* **69** (1990), 33–54.
- [13] I. Lasiecka and D. Tataru, Uniform boundary stabilization of semilinear wave equations with nonlinear boundary damping, *Diff. Int. Eqs.* **6** (2) (1993), 507–533.
- [14] J. L. Lions, *Quelques methodes de resolution des problemes aux limites non lineaires*, Dunod, Paris, 1969.
- [15] P. Martinez, A new method to obtain decay rate estimates for dissipative systems with localized damping, *Rev. Mat. Complut.* **12** (1999), 251–283.

- [16] J. Quinn and D. L. Russel, Asymptotic stability and energy decay for solutions of hyperbolic equations with boundary damping, *Proc. Roy. soc. Edinburgh, Sect A* **77** (1977), 97–127.

Cícero L. Frota and Nikolai A. Larkin
Universidade Estadual de Maringá
Departamento de Matemática
Av. Colombo, 5790
87020-900 Maringá – PR
Brazil

Some Remarks on Semilinear Resonant Elliptic Problems

J.V. Goncalves and C.A. Santos

Abstract. We study existence of solutions of the semilinear elliptic problem

$$-\Delta u = a(x)u + f(u) + h(x) \text{ in } \Omega, \quad u = 0 \text{ on } \partial\Omega,$$

where Δ is the Laplace operator, a, h are $L^2(\Omega)$ -functions with $h \neq 0$, $a \leq \lambda_1$ where λ_1 is the first eigenvalue of $(-\Delta, H_0^1(\Omega))$, $f : \mathbf{R} \rightarrow \mathbf{R}$ is unbounded and continuous, and $\Omega \subset \mathbf{R}^N$ ($N \geq 1$) is a bounded domain with smooth boundary $\partial\Omega$. We focus on “one direction resonance”, namely the case $f(s) = 0$ for $s \leq 0$ and $\inf_{s \geq 0} f(s) = -\infty$. No monotonicity condition is required upon f . Minimization arguments are exploited.

Keywords. Resonant problems, minimization arguments, one direction resonance.

1. Introduction

Our concern is on the existence of solutions of the semilinear elliptic problem,

$$-\Delta u = a(x)u + f(u) + h(x) \text{ in } \Omega, \quad u = 0 \text{ on } \partial\Omega, \quad (1.1)$$

where Δ is the Laplace operator, a, h are $L^2(\Omega)$ -functions with $h \neq 0$, $a \leq \lambda_1$ where λ_1 is the first eigenvalue of $(-\Delta, H_0^1(\Omega))$, $f : \mathbf{R} \rightarrow \mathbf{R}$ is unbounded and continuous and $\Omega \subset \mathbf{R}^N$ ($N \geq 1$) is a bounded domain with smooth boundary $\partial\Omega$.

Resonant problems have been intensively investigated since the pioneering work [9] by Landesman & Lazer which treated bounded nonlinearities f such that $f(s) \rightarrow f_{\pm}$ as $s \rightarrow \pm\infty$ with $f_{\pm} \in \mathbf{R}$. We refer the reader to Hess [6], Ahmad, Lazer & Paul [1], Rabinowitz [12], Brézis & Nirenberg [5], and their references. There is up to date a broad literature on the subject.

Among the interesting features of resonance is the so called “strong resonance” investigated by Bartolo, Benci & Fortunato [4] which refers to the case where $f_- = f_+ = 0$ with $F_\infty \in \mathbf{R}$ where $F_\infty := \lim_{|t| \rightarrow \infty} F(t)$ and F is the potential associated to f namely, $F(t) := \int_0^t f(s)ds, t \in \mathbf{R}$.

In order to further recall some specifics on resonance, in a certain sense, regarding f_-, f_+, F_∞ , we set

$$G(x, s) := a(x)s^2/2 + 2F(s)/s^2 \text{ and } A_\infty(x) := \lim_{|s| \rightarrow \infty} 2G(x, s)/s^2.$$

The extended real number

$$i(A_\infty) := \inf_{v \in H_0^1(\Omega), \|v\|_0=1} \int_\Omega (|\nabla v|^2 - A_\infty(x)v^2)dx.$$

where $\|\cdot\|_0$ stands for the $L^2(\Omega)$ norm, has played a role. In light of these notations (1.1) has been termed nonresonant if $i(A_\infty) > 0$ and resonant if $i(A_\infty) = 0$.

Nonresonant problems, in the sense that $i(A_\infty) > 0$, involving unbounded nonlinearities were addressed, for instance, by Mawhin, Ward & Willem [10] and deFigueiredo & Gossez [3]. On the other hand, resonant problems in the presence of unbounded nonlinearities were treated by Kazdan & Warner [8] and Liu & Tang [11]. See also their references.

In particular, it was shown in [11] by means of minimization arguments, the existence of a weak solution $u \in H_0^1(\Omega)$ for (1.1), under the conditions,

$$a(x) := \lambda_1, F(t) \xrightarrow{|t| \rightarrow \infty} -\infty, \int_\Omega h\varphi_1 dx = 0 \text{ with } h \in L^2(\Omega),$$

where $\varphi_1 > 0$ is the principal λ_1 -eigenfunction. We point out that for suitable values of $N \geq 3$, the function

$$f(s) = -\frac{2s}{1+s^2} + \frac{2N}{N-2} s^{\frac{N+2}{N-2}} \cos(s^{\frac{2N}{N-2}})$$

satisfies the conditions of [11] and actually $i(A_\infty) = 0$.

However, a new concept of resonance termed “one direction resonance” was exploited by Kannan & Ortega [7] and Cuesta, de Figueiredo & Srikanth [2]. In fact, it was shown in [2], by means of sharp *a priori* elliptic estimates and the Leray-Schauder degree theory, the existence of a strong solution $u \in W^{2,r}(\Omega) \cap H_0^1(\Omega)$ for (1.1) under the conditions

$$f(s) = (s^+)^{\sigma} \text{ with } 1 < \sigma < \frac{N+1}{N-1}, \int_\Omega h\varphi_1 dx < 0 \text{ and } h \in L^r(\Omega), r > N.$$

Motivated by [2] we focus back on “one direction resonance” at the first eigenvalue of $(-\Delta, H_0^1(\Omega))$ by studying a situation in which the function f satisfies a condition like

$$f(s) = 0 \text{ for } s \leq 0 \text{ and } \inf_{s \geq 0} f(s) = -\infty$$

but with no monotonicity assumption upon f . Our result complements the ones mentioned above in the sense that regarding [11] we treat “one direction resonance” and, with respect to [2] we study existence of solutions of (1.1) with f as above and $h \in L^2(\Omega)$ satisfying

$$\int_{\Omega} h\varphi_1 dx > 0. \tag{1.2}$$

We set

$$f(t) := \beta(t) (t^+)^{\sigma}, \quad t \in \mathbf{R},$$

where $1 \leq \sigma \leq 2N/(N - 2)$ if $N \geq 3$, $1 \leq \sigma < \infty$ if $N = 1, 2$ and β is a bounded continuous function satisfying

$$\sup_{t \geq M} \beta(t) < 0 \text{ for some } M > 0. \tag{1.3}$$

The energy functional associated to (1.1) is

$$I(u) = \frac{1}{2} \int_{\Omega} |\nabla u|^2 dx - \frac{1}{2} \int_{\Omega} a(x)u^2 dx - \int_{\Omega} F(u)dx - \int_{\Omega} hudx, \quad u \in H_0^1(\Omega).$$

We point out that depending on the choice of σ , I satisfies $-\infty < I(u) \leq \infty$ and thus may not be differentiable. The positive and negative parts of a function u will be denoted by u^{\pm} .

Our main result is:

Theorem 1.1. *If (1.2), (1.3) and $a \leq \lambda_1$ hold, there is $u \in H_0^1(\Omega)$, $u^+ \neq 0$, such that*

$$\int_{\Omega} \nabla u \nabla \varphi dx = \int_{\Omega} au\varphi dx + \int_{\Omega} \beta(u)(u^+)^{\sigma} \varphi dx + \int_{\Omega} h\varphi dx, \quad \varphi \in H_0^1(\Omega) \cap L^{\infty}(\Omega). \tag{1.4}$$

Furthermore,

$$\int_{\Omega} hu^- dx \leq 0 \text{ when } 1 \leq \sigma \leq (N + 2)/(N - 2). \tag{1.5}$$

Remark. (i) If either $N = 1, 2$ and $1 \leq \sigma < \infty$ or $N \geq 3$ and $1 \leq \sigma \leq (N + 2)/(N - 2)$, then (1.4) holds with $\varphi \in H_0^1(\Omega)$.

(ii) Condition (1.2) is, in a certain respect, necessary to get some $u \in H_0^1(\Omega)$ with $u^+ \neq 0$ satisfying (1.4). Indeed, if $u \in H_0^1(\Omega)$ satisfies (1.4),

$$a = \lambda_1, \quad \int_{\Omega} h\varphi_1 dx \leq 0 \text{ and } \beta < 0,$$

then it easily follows that $u^+ = 0$.

Examples. Functions β satisfying (1.3) are obtained by making

- (i) $\beta(s) := 0$ for $s < 0$, $\beta(s) := s^a - s^b$ for $s \in [0, M]$, $\beta(s) := \beta(M)$ for $s > M$ for some $M > 0$ and for suitable values of $b > a$,

or

$$(ii) \quad \beta(s) := -[2 + \sin(s)], \quad s \in \mathbf{R}.$$

2. Proof of Theorem 1.1

The main part of the proof consists in showing that the energy functional I is weakly sequentially lower semicontinuous, wslsci for short, and coercive. With this we get a point of minimum u of I and subsequently show that u satisfies the conditions asserted in Theorem 1.1.

Lemma 2.1. *Assume (1.3) and $a \leq \lambda_1$. Then I is wslsci.*

Proof. Let $u_n \in H_0^1(\Omega)$ such that $u_n \rightharpoonup u$ for some $u \in H_0^1(\Omega)$. Passing to subsequences we have

$$u_n \longrightarrow u \text{ in } L^2(\Omega), \quad u_n \longrightarrow u \text{ a.e. in } \Omega, \quad |u_n| \leq \theta \text{ in } \Omega$$

for some $\theta \in L^2(\Omega)$. Of course,

$$u_n^+ \longrightarrow u^+ \text{ and } u_n^+ \leq \theta \text{ a.e. in } \Omega.$$

Now, set $\delta := -\sup_{t \geq M} \beta(t)$ and notice that for $t \geq M$,

$$\begin{aligned} F(t) &\leq \int_0^M \beta(s)(s^+)^\sigma ds - \delta \int_M^t (s^+)^\sigma ds \\ &\leq M_0 - \frac{\delta}{\sigma+1} \left(t^{\sigma+1} - M^{\sigma+1} \right), \end{aligned}$$

so that $F(t) \rightarrow -\infty$ as $t \rightarrow +\infty$ and hence

$$F(t) \leq F_\infty \text{ for all } t \in \mathbf{R} \text{ and for some } F_\infty > 0. \tag{2.1}$$

Moreover, using

$$a(x)u_n^2 \leq \lambda_1 u_n^2 \leq \lambda_1 \theta^2, \text{ a.e. in } \Omega,$$

it follows by Fatou's lemma

$$\begin{aligned} \underline{\lim} I(u_n) &\geq \frac{1}{2} \underline{\lim} \int_\Omega |\nabla u_n|^2 dx - \frac{1}{2} \overline{\lim} \int_\Omega a u_n^2 dx - \overline{\lim} \int_\Omega F(u_n) dx \\ &\quad - \lim \int_\Omega h u_n dx \\ &\geq \frac{1}{2} \int_\Omega |\nabla u|^2 dx - \frac{1}{2} \int_\Omega a u^2 dx - \int_\Omega F(u) dx - \int_\Omega h u dx = I(u). \end{aligned}$$

This proves Lemma 2.1. □

Lemma 2.2. *Assume (1.2) – (1.3) and $a \leq \lambda_1$. Then I is coercive.*

Proof. Assume, on the contrary, there is some $u_n \in H_0^1(\Omega)$ such that $\|u_n\| \rightarrow \infty$ but $I(u_n)$ is bounded from above, say $I(u_n) \leq C$ for some $C > 0$. Thus

$$C \geq \frac{1}{2} \int_{\Omega} |\nabla u_n|^2 dx - \frac{1}{2} \int_{\Omega} a u_n^2 dx - \int_{\Omega} F(u_n) dx - \int_{\Omega} h u_n dx.$$

Dividing by $\|u_n\|^2$ and letting $v_n := u_n/\|u_n\|$ we get

$$\frac{C}{\|u_n\|^2} \geq \frac{1}{2} - \frac{1}{2} \int_{\Omega} a v_n^2 dx - \int_{\Omega} \frac{F(u_n)}{\|u_n\|^2} dx - \frac{1}{\|u_n\|} \int_{\Omega} h v_n dx.$$

Remarking that

$$v_n \rightarrow v \text{ in } L^2(\Omega), \quad v_n \rightarrow v \text{ a.e. in } \Omega, \quad |v_n| \leq \tilde{\theta} \text{ in } \Omega$$

for some $\tilde{\theta} \in L^2(\Omega)$ it follows by using (2.1), applying Fatou's lemma and Lebesgue's theorem that

$$0 \geq \frac{1}{2} - \frac{1}{2} \int_{\Omega} a v^2 dx - \int_{\Omega} \overline{\lim} \frac{F(u_n)}{\|u_n\|^2} dx. \tag{2.2}$$

By (2.1) and (2.2),

$$\lambda_1 \int_{\Omega} v^2 dx \geq \int_{\Omega} a v^2 dx \geq 1 \geq \underline{\lim} \|v_n\|^2 \geq \|v\|^2 \geq \lambda_1 \int_{\Omega} v^2 dx$$

showing that v is a λ_1 -eigenfunction and, in addition, that

$$\int_{\Omega} a v^2 dx = \lambda_1 \int_{\Omega} v^2 dx = \int_{\Omega} |\nabla v|^2 dx = 1. \tag{2.3}$$

As a consequence, $v = \alpha \varphi_1$ for some $\alpha \neq 0$.

We contend that $\alpha < 0$. Indeed, if otherwise $\alpha > 0$, then $v > 0$, so that

$$v_n^+ \rightarrow v, \quad v_n^- \rightarrow 0 \text{ and } u_n^+ \rightarrow +\infty \text{ a.e. in } \Omega.$$

As a consequence, for each x and n large enough,

$$\frac{F(u_n(x))}{\|u_n\|^2} \leq \frac{\tilde{C}}{\|u_n\|^2} - \frac{\delta}{\sigma + 1} (u_n^+)^{\sigma-1} (v_n^+)^2 \tag{2.4}$$

for some constant $\tilde{C} > 0$. Now, we distinguish between two cases.

If $\sigma = 1$, then by (2.2)–(2.4),

$$0 \geq \frac{1}{2} (1 - \int_{\Omega} a v^2 dx) + \frac{\delta}{\sigma + 1} \int_{\Omega} v^2 dx = \frac{\delta}{\sigma + 1} \int_{\Omega} v^2 dx > 0$$

which is impossible.

If $\sigma > 1$, by (2.2)–(2.4) again,

$$0 \geq \frac{1}{2} (1 - \int_{\Omega} a v^2 dx) + \frac{\delta}{\sigma + 1} \int_{\Omega} \underline{\lim} (v_n^+)^2 (u_n^+)^{\sigma-1} dx \geq +\infty,$$

impossible. Hence $\alpha < 0$. As a consequence,

$$v_n^+ \rightarrow 0, \quad v_n^- \rightarrow -\alpha \varphi_1 \text{ a.e. in } \Omega.$$

Now since

$$\begin{aligned}
 C &\geq \frac{1}{2} \int_{\Omega} |\nabla u_n|^2 dx - \frac{1}{2} \int_{\Omega} a u_n^2 dx - \int_{\Omega} F(u_n) dx - \int_{\Omega} h u_n dx \\
 &\geq \frac{1}{2} \int_{\Omega} |\nabla u_n|^2 dx - \frac{\lambda_1}{2} \int_{\Omega} u_n^2 dx - \int_{\Omega} F(u_n) dx - \int_{\Omega} h u_n dx \\
 &\geq - \int_{\Omega} F(u_n) dx - \int_{\Omega} h u_n dx,
 \end{aligned}$$

by dividing the inequality above by $\|u_n\|$ and recalling that $v_n = u_n/\|u_n\|$, we get

$$\frac{C}{\|u_n\|} \geq - \int_{\Omega} \frac{F(u_n)}{\|u_n\|} dx - \int_{\Omega} h v_n dx. \tag{2.5}$$

Now using (2.1) and the fact that $\|u_n\| \rightarrow \infty$ we get for large n ,

$$\frac{F(u_n(x))}{\|u_n\|} \leq \frac{F_{\infty}}{\|u_n\|} \leq F_{\infty}.$$

Applying Fatou’s lemma in (2.5) we find

$$0 \geq - \int_{\Omega} \overline{\lim} \frac{F(u_n)}{\|u_n\|} dx - \lim \int_{\Omega} h v_n dx \geq -\alpha \int_{\Omega} h \varphi_1 dx > 0,$$

impossible. Thus I is coercive. This proves Lemma 2.2. □

Proof of Theorem 1.1 (Finished). By Lemmas 2.1 and 2.2,

$$I(u) = \min_{\varphi \in H_0^1(\Omega)} I(\varphi) \text{ for some } u \in H_0^1(\Omega).$$

In order to show that $I(u) < 0$, notice at first that $I(0) = 0$. Picking $t \in (0, 1)$ we have

$$F(t\varphi_1) = F(t\varphi_1) - F(0) = \beta(\theta_t) (\theta_t^+)^{\sigma} t\varphi_1, \quad 0 \leq \theta_t \leq t\varphi_1.$$

By computing we get

$$\begin{aligned}
 I(t\varphi_1) &= \frac{t^2}{2} \int_{\Omega} (\lambda_1 - a)\varphi_1^2 dx + \int_{\Omega} F(t\varphi_1) dx - t \int_{\Omega} h\varphi_1 dx \\
 &\leq \frac{t^2}{2} \int_{\Omega} (\lambda_1 - a)\varphi_1^2 dx + \int_{\Omega} t|\beta(\theta_t)||\theta_t|^{\sigma}\varphi_1 - t \int_{\Omega} h\varphi_1 dx \\
 &\leq \alpha_0 t^2 + \alpha_1 t^{\sigma+1} - \alpha_2 t,
 \end{aligned}$$

for some positive constants α_i . Making t sufficiently small we have $I(t\varphi_1) < 0$.

Since u is a point of minimum of I over $H_0^1(\Omega)$,

$$\frac{I(u + \epsilon\varphi) - I(u)}{\epsilon} \geq 0, \quad \varphi \in H_0^1(\Omega) \cap L^{\infty}(\Omega).$$

On the other hand,

$$\frac{F(u + \epsilon\varphi) - F(u)}{\epsilon} = \frac{1}{\epsilon} \int_u^{u+\epsilon\varphi} \beta(t)(t^+)^{\sigma} dt = \beta(\theta_{\epsilon})(\theta_{\epsilon}^+)^{\sigma} \varphi,$$

where

$$\min\{u + \epsilon\varphi, u\} \leq \theta_{\epsilon} \leq \max\{u + \epsilon\varphi, u\}.$$

Remarking that

$$\beta(\theta_{\epsilon})(\theta_{\epsilon}^+)^{\sigma} \rightarrow \beta(u)(u^+)^{\sigma} \text{ and } |\theta_{\epsilon}| \leq |u| + |\varphi| \text{ a.e. in } \Omega,$$

(1.4) follows by Fatou’s lemma.

Next we show that $u^+ \neq 0$. Indeed, assume by the way of contradiction that $u^+ = 0$. Then $u = -u^-$. Making $\varphi = \varphi_1$ in (1.4) we get

$$\begin{aligned} \int_{\Omega} h\varphi_1 dx &= - \left[\int_{\Omega} \nabla\varphi_1 \nabla u^- dx - \int_{\Omega} a\varphi_1 u^- dx \right] \\ &\leq \left[\int_{\Omega} \nabla\varphi_1 \nabla u^- dx - \lambda_1 \int_{\Omega} \varphi_1 u^- dx \right] = 0, \end{aligned}$$

contradicting (1.2).

To show (1.5), recall that if $1 \leq \sigma \leq (N + 2)/(N - 2)$ with $N \geq 3$ or $1 < \sigma < \infty$ with $N = 1, 2$, then $I \in C^1(H_0^1(\Omega), \mathbf{R})$ so that

$$\int_{\Omega} \nabla u \nabla \varphi dx = \int_{\Omega} a u \varphi dx + \int_{\Omega} f(u) \varphi dx + \int_{\Omega} h \varphi dx, \quad \varphi \in H_0^1(\Omega).$$

Taking $\varphi = u^-$ above we get

$$\begin{aligned} \int_{\Omega} h u^- dx &= - \left[\int_{\Omega} |\nabla u^-|^2 dx - \int_{\Omega} a (u^-)^2 dx \right] \\ &\leq \left[\int_{\Omega} |\nabla u^-|^2 dx - \lambda_1 \int_{\Omega} (u^-)^2 dx \right] \leq 0. \end{aligned}$$

This proves Theorem 1.1. □

References

- [1] S. Ahmad, A. Lazer and J.L. Paul, *Elementary critical point theory and perturbations of elliptic boundary value problems at resonance*, Indiana Univ. Math. J., 25 (1976), 933–944.
- [2] M. Cuesta, D.G. de Figueiredo and P. Srikanth, *On a resonant-superlinear elliptic problem*, Calc. Var., 17 (2003), 221–233.
- [3] D.G. de Figueiredo and J.P. Gossez, *Un probleme elliptique semilinéaire sans condition de croissance*, CRAS Paris, 308 (1989), 277–289.
- [4] P. Bartolo, V. Benci and D. Fortunato, *Abstract critical point theorems and applications to some nonlinear problems with strong resonance at infinity*, Nonlinear Anal., 7 (1983), 981–1012.

- [5] H. Brézis and L. Nirenberg, *Characterizations of the ranges of some nonlinear operators and applications to boundary value problems*, Ann. Scuola Norm. Sup. Pisa, 5 (1978), 225–326.
- [6] P. Hess, *On a theorem by Landesman and Lazer*, Indiana Univ. Math. J., 23 (1974), 827–829.
- [7] R. Kannan and R. Ortega., *Landesman-Lazer conditions for problems with “one sided unbounded” nonlinearities*, Nonlinear Anal., 9 (1985), 1313–1317.
- [8] J. Kazdan and F. Warner, *Remarks on some quasilinear elliptic equations*, Comm. Pure Appl. Math., XXVIII (1975), 567–597.
- [9] E.M. Landesman and A.C. Lazer, *Nonlinear perturbations of linear elliptic boundary value problems at resonance*, J. Math. Mech., 19 (1970), 609–623.
- [10] J. Mawhin, J. Ward and M. Willem, *Variational methods and semilinear elliptic equations*, Arch. Rat. Mech. Anal., 95 (1986), 269–277.
- [11] S.Q. Liu and C.L. Tang, *Existence and multiplicity of solutions for a class of semilinear elliptic problems*, J. Math. Anal. Appl., 257 (2001), 321–331.
- [12] P. Rabinowitz, *Some minimax theorems and applications to nonlinear partial differential equations*, Nonlinear Analysis, Academic Press, (1978), 161–177.

J.V. Goncalves
Universidade de Brasília
Departamento de Matemática
70910-900 Brasília, DF
Brazil
e-mail: jv@mat.unb.br

C.A. Santos
Universidade Federal de Goiás
Departamento de Matemática
75705-220 Catalão, GO
Brazil
e-mail: csantos@unb.br

Remarks on Regularity Theorems for Solutions to Elliptic Equations via the Ultracontractivity of the Heat Semigroup

Otared Kaviani

Abstract. In this paper we show how elliptic regularity results can be obtained as a consequence of the ultracontractivity of the underlying heat semigroup. For instance for $f \in L^p(\Omega)$ and $V \in L^1_{\text{loc}}(\Omega)$ with $V^- \in L^q(\Omega)$ and $\min(p, q) > \frac{N}{2}$, if $u \in H^1_0(\Omega)$ satisfies $-\Delta u + Vu = f$ then, using only the fact that the heat semigroup $\exp(t\Delta)$ is ultracontractive, that is for $t > 0$ one has $\|\exp(t\Delta)u_0\|_\infty \leq t^{-N/2}\|u_0\|_{L^1}$, one may show easily that $u \in L^\infty(\Omega)$. The same approach can be used in order to establish regularity results, such as the Hölderianity, or L^p estimates, for solutions to quite general elliptic equations. Indeed such results are now classical and well known, and our main point here is to present rather elementary proofs using only the maximum principle and the ultracontractivity of the underlying heat semigroup.

1. Introduction

In an attempt to attract the reader's attention, we begin with the following example. Let $u \in L^p(\mathbb{R}^N)$, for some $1 \leq p < \infty$, and $f \in L^q(\mathbb{R}^N)$ be such that

$$-\Delta u = f \quad \text{in } \mathbb{R}^N. \tag{1.1}$$

We wish to show in an “elementary” way that if $q > N/2$ we have $u \in C_0(\mathbb{R}^N)$. Indeed, if $v(t, x)$ denotes the unique solution of the heat equation $\partial_t v - \Delta v = f$ with the initial condition $v(0, x) = u(x)$, clearly we have $v \equiv u$. Now, denoting by $S(t)$ the heat semigroup on \mathbb{R}^N , which is given by $S(t)u_0 := G_t * u_0$, where $G_t(x) := (4\pi t)^{-N/2} \exp(-|x|^2/4t)$ denotes the Gaussian heat kernel, the solution v of the latter heat equation is given by:

$$v = S(t)u + \int_0^t S(t-\tau)f \, d\tau = S(t)u + \int_0^t S(\tau)f \, d\tau. \tag{1.2}$$

Since $G_t * u_0 \in C_0(\mathbb{R}^N)$ for $u_0 \in L^r(\mathbb{R}^N)$, upon using Young’s inequality for convolutions between $L^q(\mathbb{R}^N)$ and $L^{q'}(\mathbb{R}^N)$ (where $q' := q/(q - 1)$ and $r' = r/(r - 1)$), we know that

$$\|S(t)u_0\|_\infty = \|G_t * u_0\|_\infty \leq \|G_t\|_{r'} \|u_0\|_r = ct^{-\beta(r)}\|u_0\|_r, \quad \text{with } \beta(r) := \frac{N}{2r}.$$

Thus, noting that $\|S(\tau)f\|_\infty \leq c\tau^{-\beta(q)}\|f\|_q$, and taking the L^∞ norm in (1.2), since $v \equiv u$ while f is independent of t and $\beta(q) = N/2q < 1$, we obtain

$$\|u\|_\infty \leq ct^{-\beta(p)}\|u\|_p + c \int_0^t \tau^{-\beta(q)} d\tau \|f\|_q = ct^{-\beta(p)}\|u\|_p + ct^{1-\beta(q)}\|f\|_q,$$

and finally, upon taking the minimum of the right hand side on $t > 0$, we obtain also an interpolation inequality of Gagliardo-Nirenberg type

$$\|u\|_\infty \leq c \|u\|_p^{1-\alpha} \|f\|_q^\alpha, \quad \text{where } \alpha \left(\frac{2}{N} + \frac{1}{p} - \frac{1}{q} \right) := \frac{1}{p}.$$

Actually (1.2) shows that $u \in C_0(\mathbb{R}^N)$: indeed the first term $S(t)u$, as a convolution between $L^p(\mathbb{R}^N)$ and $L^{p'}(\mathbb{R}^N)$, is clearly in $C_0(\mathbb{R}^N)$, and the integral term is the limit, in L^∞ norm, of $z_\varepsilon := \int_\varepsilon^t S(\tau)f d\tau$ as $\varepsilon \rightarrow 0^+$. Since for $\varepsilon \leq \tau \leq t$ we have $S(\tau)f \in C_0(\mathbb{R}^N)$, it follows that $z_\varepsilon \in C_0(\mathbb{R}^N)$, and finally one sees that $u \in C_0(\mathbb{R}^N)$.

As one may see, the fact that the heat semigroup $S(t)$ maps $L^q(\mathbb{R}^N)$ into $L^\infty(\mathbb{R}^N)$ with a norm of order $t^{-\beta(q)}$ where $\beta(q) < 1$, is the key argument of this proof. However, this property, called the ultracontractivity of the heat semigroup $S(t)$, may be proved in a rather simple way for a large class of heat semigroups generated by quite general elliptic operators.

Classically the proof of regularity results for solutions of second order elliptic equations makes use of inequalities such as the Sobolev inequality (with $2^* := 2N/(N - 2)$ when $N \geq 3$),

$$\text{for all } \varphi \in C_c^\infty(\mathbb{R}^N), \quad \|\varphi\|_{2^*} \leq c \|\nabla\varphi\|_2, \tag{1.3}$$

or the Gagliardo–Nirenberg variant of it

$$\text{for all } \varphi \in C_c^\infty(\mathbb{R}^N), \quad \|\varphi\|_q \leq c(p, N) \|\varphi\|_p^{1-\theta} \|\nabla\varphi\|_2^\theta, \quad \text{where } \frac{1}{q} = \frac{1-\theta}{p} + \frac{\theta}{2^*}, \tag{1.4}$$

or the Nash inequality,

$$\text{for all } \varphi \in C_c^\infty(\mathbb{R}^N), \quad \|\varphi\|_2^{(2N+4)/N} \leq c \|\varphi\|_1^{4/N} \|\nabla\varphi\|_2^2. \tag{1.5}$$

Since the works of M. Fukushima [8], N. Th. Varopoulos [15], E. B. Fabes & D.W. Strook [7] it is known that there exists an equivalence between certain Sobolev type inequalities and the ultracontractivity of the heat semigroup. To be more specific, let us consider the case of a domain $\Omega \subset \mathbb{R}^N$ with $N \geq 2$ and the heat semigroup associated with the Laplacian on Ω and the Dirichlet

boundary condition. If we denote by $S(t) := \exp(t\Delta)$ the heat semigroup, that is $S(t)u_0 := u(t)$ where $u(t)$ is the solution of the linear heat equation

$$\begin{cases} \partial_t u - \Delta u &= 0 & \text{in } (0, \infty) \times \Omega \\ u(t, \sigma) &= 0 & \text{on } (0, \infty) \times \partial\Omega \\ u(0, x) &= u_0(x) & \text{in } \Omega, \end{cases} \tag{1.6}$$

it is known that $S(t)$ is ultracontractive, that is it maps $L^1(\Omega)$ into $L^\infty(\Omega)$, more precisely for $1 \leq q \leq r \leq \infty$ we have (here $\|\cdot\|_p$ is the norm of the Lebesgue space $L^p(\Omega)$ for $1 \leq p \leq \infty$):

$$\text{for all } t > 0, \quad \|S(t)u_0\|_r \leq (4\pi t)^{-\beta} \|u_0\|_q, \quad \text{where } \beta := \frac{N}{2} \left(\frac{1}{q} - \frac{1}{r} \right). \tag{1.7}$$

Since the publication of the above mentioned works of M. Fukushima, N.Th. Varopoulos, E.B. Fabes & D.W. Strook, it is remarkably known that if $N > 2$ and $2^* := 2N/(N - 2)$, the inequality (1.7) (actually for $(q, r) = (1, \infty)$) is equivalent to the Sobolev inequality (1.3) and, when $N \geq 1$, it is equivalent to the Nash inequality (1.5) (see for instance the very nice exposition given by E.B. Davies in [6]). In this note we would like to show how the direct use of the ultracontractivity property (1.7) may yield most, if not all, of the classical regularity theorems for solutions of elliptic equations in a significantly simpler way. Indeed one has to prove the ultracontractivity of the heat semigroup via a rather simple method which *does not* make use of regularity results for the elliptic equation...

In the following we are not going to show the whole range of applications of this point of view, although other regularity results may be established, such as interior Schauder estimates, or De Giorgi–Nash theorem on the Hölderianity of solutions of some linear elliptic equations. We believe that although all the regularity results and a priori estimates we present here may be obtained via other methods, our approach seems quite simple and presents a unifying point of view of such results.

The remainder of this paper is organized as follows. In section 2 we gather a few results, in particular the ultracontractivity property, concerning the heat semigroup associated to elliptic operators of the form $Lu := -\operatorname{div}(a\nabla u) + Vu$ or more generally

$$Lu := -\operatorname{div}(a\nabla u) + \operatorname{div}(\mathbf{b}u) + \mathbf{c} \cdot \nabla u + Vu.$$

In section 3 we prove classical results about L^p estimates of solutions to equations such as $Lu = f$. In section 4 we apply the same method for the study of regularity of solutions of $Lu = \operatorname{div}(\mathbf{g})$.

2. Ultracontractivity of general heat semigroups

In this section we gather a few known results on heat semigroups, more precisely those properties needed in the remainder of this paper, and which do not depend on regularity results concerning solutions of elliptic equations. Indeed our aim is

the establishment of such regularity results using only the maximum principle and the ultracontractivity of the heat semigroup.

We begin with the well known and easy case of the classical Laplacian on the whole space \mathbb{R}^N . We wish to emphasize that obtaining regularity results for operators such as $Lu := -\Delta u + Vu$ acting (for instance) on $H_0^1(\Omega)$, is quite elementary and relies on two facts: one is the knowledge of the Gaussian kernel for the heat equation in \mathbb{R}^N , the other being the maximum principle. In the case $\Omega := \mathbb{R}^N$, if we denote for $t > 0$ by G_t the Gaussian kernel

$$G_t(x) := (4\pi t)^{-N/2} \exp\left(-\frac{|x|^2}{4t}\right),$$

then for $u_0 \in L^1(\mathbb{R}^N)$ (or even in some distribution space where the convolution with a Gaussian makes sense) the function

$$u(t, x) := (G_t * u_0)(x) = \int_{\mathbb{R}^N} G_t(x - y)u_0(y)dy,$$

is the unique solution of the heat equation

$$\begin{cases} \partial_t u - \Delta u = 0 & \text{in } (0, \infty) \times \mathbb{R}^N \\ \lim_{t \rightarrow 0^+} u(t) = u_0 & \text{in } L^1(\mathbb{R}^N). \end{cases} \quad (2.1)$$

Now, by Young's inequality for convolution between Lebesgue spaces $L^p(\mathbb{R}^N)$ and $L^q(\mathbb{R}^N)$, it is clear that provided $1 \leq r \leq \infty$ we have

$$\|G_t * u_0\|_r \leq \|G_t\|_p \|u_0\|_q, \quad \text{with } \frac{1}{r} := \frac{1}{p} + \frac{1}{q} - 1. \quad (2.2)$$

Hence, since $(p-1)/p = (1/q) - (1/r)$ and $\|G_t\|_p = p^{-N/2p} (4\pi t)^{-N(p-1)/2p}$, (here $1 \leq p \leq \infty$) one sees that the semigroup $S_0(t)$ defined by $S_0(t)u_0 := u(t) = G_t * u_0$ is ultracontractive and that for $1 \leq q \leq r \leq \infty$ it satisfies

$$\text{for all } t > 0, \quad \|S(t)u_0\|_r \leq (4\pi t)^{-\beta} \|u_0\|_q, \quad \text{where } \beta := \frac{N}{2} \left(\frac{1}{q} - \frac{1}{r} \right). \quad (2.3)$$

It should be noted that instead of a convolution between $L^p(\mathbb{R}^N)$ and $L^q(\mathbb{R}^N)$ we could have used a convolution between the Marcinkiewicz (or weak- L^p) space $M^p(\mathbb{R}^N)$ (or even between Lorentz spaces $L^{p_0, p_1}(\mathbb{R}^N)$) and $L^q(\mathbb{R}^N)$. However since $\|G_t\|_{M^p} = c(p, N)t^{-N(p-1)/2p}$, in terms of ultracontractivity of the heat semigroup, there is no gain in doing so, and moreover the convolution between $M^p(\mathbb{R}^N)$ and $L^s(\mathbb{R}^N)$ requires $1 < r < \infty$. Nevertheless one should bear in mind that upon using slightly better results concerning convolutions between Lorentz spaces, one may carry out the same kind of analysis and obtain more precise results regarding regularity of solutions to elliptic equations when the data are supposed to be in such spaces. However in these notes we restrict ourselves to the more classical Lebesgue spaces.

Observe also that if $u_0 \geq 0$ and does not vanish identically, then $S(t)u_0 > 0$, that is we have the parabolic maximum principle, or the comparison principle, if

$u_0 \neq v_0$,

$$u_0 \geq v_0 \implies S(t)u_0 > S(t)v_0.$$

There is another interesting property of the heat semigroup on \mathbb{R}^N , which can be obtained quite easily: if $\mathbf{g} \in (L^{q_1}(\mathbb{R}^N))^N$ for some $1 < q_1 < \infty$, then $\operatorname{div}(\mathbf{g}) \in W^{-1,q_1}(\mathbb{R}^N)$ and one can define $S_0(t)(\operatorname{div}(\mathbf{g}))$. Actually, after a standard regularization process on \mathbf{g} , one can see that (here we denote by $\xi \cdot \eta$ the Euclidian scalar product of $\xi, \eta \in \mathbb{R}^N$):

$$S_0(t)(\operatorname{div}(\mathbf{g})) = - \sum_{j=1}^N (\partial_j G_t) * \mathbf{g}_j = \int_{\mathbb{R}^N} \frac{(x-y)}{2t} G_t(x-y) \cdot \mathbf{g}(y) dy.$$

One concludes that, provided $(p-1)/p = (1/q_1) - (1/r) \geq 0$, for $t > 0$ we have $S_0(t)(\operatorname{div}(\mathbf{g})) \in L^p(\mathbb{R}^N)$, and that

$$\|S_0(t)(\operatorname{div}(\mathbf{g}))\|_r \leq c(N, r, q_1) t^{-\beta_1} \|\mathbf{g}\|_{q_1} \quad \text{where } \beta_1 := \frac{N}{2} \left(\frac{1}{q_1} - \frac{1}{r} \right) + \frac{1}{2}. \tag{2.4}$$

This means that the heat semigroup on \mathbb{R}^N has also a *regularizing property* which consists in mapping Sobolev spaces with negative exponents, W^{-1,q_1} , into Lebesgue spaces L^{q_1} , with a norm of order $t^{-1/2}$. This feature is related to the analyticity of the semigroup, and we shall consider below other cases of analytic heat semigroups, although in those cases the proof of this property is not as elementary as the one just described.

Now consider the case of a potential $V_0 \in L^1_{\text{loc}}(\mathbb{R}^N)$ such that $V_0 \geq 0$. Then one can show that for $u_0 \in L^1(\mathbb{R}^N)$ and $u_0 \geq 0$ the heat equation

$$\begin{cases} \partial_t u - \Delta u + V_0 u = 0 & \text{in } (0, \infty) \times \mathbb{R}^N \\ \lim_{t \rightarrow 0^+} u(t) = u_0 & \text{in } L^1(\mathbb{R}^N), \end{cases} \tag{2.5}$$

has a unique solution $u(t)$ in $L^1(\mathbb{R}^N)$ and that, by the parabolic maximum principle, one has $0 \leq u(t) \leq S_0(t)u_0$. By splitting an initial data u_0 into $u_0 = u_0^+ - u_0^-$ (where, as usual, $z^+ := \max(z, 0)$ and $z^- := \max(-z, 0)$) it follows that for any $u_0 \in L^1(\mathbb{R}^N)$ equation (2.5) has a unique solution $u(t)$ which satisfies $|u(t)| \leq S_0(t)|u_0|$ and therefore, if we denote by $S_{V_0}(t)u_0 := u(t)$, then for $1 \leq q \leq r \leq \infty$ we have

$$\|S_{V_0}(t)u_0\|_r \leq (4\pi t)^{-\beta} \|u_0\|_q, \quad \text{with } \beta := \frac{N}{2} \left(\frac{1}{q} - \frac{1}{r} \right). \tag{2.6}$$

All this means to us is that, as far as we are concerned with the ultracontractivity of the heat semigroup, the adjunction of a nonnegative potential to the elliptic operator does not change the picture.

One can also consider the case of an operator $u \mapsto -\Delta u + Vu$ where the potential $V \in L^1_{\text{loc}}(\mathbb{R}^N)$ satisfies $V \geq -\omega$, for some $\omega \geq 0$. In this case the ultracontractivity of the heat semigroup holds, except that (2.6) should be replaced with

$$\|S_V(t)u_0\|_r \leq e^{\omega t} (4\pi t)^{-\beta} \|u_0\|_q, \quad \text{with } \beta := \frac{N}{2} \left(\frac{1}{q} - \frac{1}{r} \right). \tag{2.7}$$

However in our approach to the proof of the regularity of solutions to elliptic equations we will not use this and, as we shall see below, we treat negative parts of the potentials in a more ad hoc way (and in fact we shall require that $V^- \in L^\infty(\Omega) + L^q(\Omega)$ for some $q > N/2$).

Now consider the case of a locally Lipschitz domain Ω and, for a nonnegative potential $V_0 \in L^1_{\text{loc}}(\Omega)$, the heat equation

$$\begin{cases} \partial_t u - \Delta u + V_0 u = 0 & \text{in } (0, \infty) \times \Omega \\ u(t, \sigma) = 0 & \text{on } (0, \infty) \times \partial\Omega \\ \lim_{t \rightarrow 0^+} u(t) = u_0 & \text{in } L^1(\Omega). \end{cases} \tag{2.8}$$

Again, using the maximum principle, one may show that $t \mapsto u(t)$ defines a continuous semigroup which is ultracontractive. Indeed for a function f defined on Ω denote by \tilde{f} its extension over all \mathbb{R}^N by zero, i.e. $\tilde{f}(x) = f(x)$ for $x \in \Omega$ and $\tilde{f}(x) = 0$ otherwise. Then the solution w of

$$\begin{cases} \partial_t w - \Delta w + \tilde{V}_0 w = 0 & \text{in } (0, \infty) \times \mathbb{R}^N \\ \lim_{t \rightarrow 0^+} w(t) = |\tilde{u}_0| & \text{in } L^1(\mathbb{R}^N), \end{cases} \tag{2.9}$$

is a super-solution to (2.8), and $|u(t, x)| \leq w(t, x)$. Since according to (2.7) we have $\|w(t)\|_r \leq (4\pi t)^{-\beta} \|\tilde{u}_0\|_q$, finally if we denote by $S(t)u_0 := u(t)$, we have that for $1 \leq q \leq r \leq \infty$

$$\|S(t)u_0\|_r \leq (4\pi t)^{-\beta} \|u_0\|_q, \quad \text{with } \beta := \frac{N}{2} \left(\frac{1}{q} - \frac{1}{r} \right). \tag{2.10}$$

As we may see, up to this point, the ultracontractivity of the semigroup generated by $-\Delta + V_0$ on $L^q(\Omega)$ for $1 \leq q \leq \infty$ is obtained by quite elementary use of the maximum principle. Now for semigroups generated by more general self-adjoint elliptic operators, the regularizing property (2.4) and the ultracontractivity property hold, but their proofs involve more sophisticated techniques (see J. Nash [11], D. Aronson [1], E.B. Davies [6], Th. Coulhon, L. Saloff-Coste & N.T. Varopoulos [5], P. Auscher [2]).

The results mentioned in the above papers can easily be adapted to cover non self-adjoint operators, and for the sake of completeness and for the reader's convenience we treat this case below. In the remainder of this paper we shall consider a Lipschitz domain $\Omega \subset \mathbb{R}^N$ (which may be bounded or not) and an operator L defined on $H^1_0(\Omega)$ by:

$$Lu := -\text{div}(a\nabla u) + \text{div}(\mathbf{b}u) + \mathbf{c} \cdot \nabla u + V_0 u, \tag{2.11}$$

where the coefficients $a, \mathbf{b}, \mathbf{c}$ and V_0 satisfy the following conditions:

$$\begin{aligned} a &:= (a_{ij})_{1 \leq i, j \leq N} \in (L^\infty(\Omega))^{N \times N}, \\ \exists \gamma_* > 0, \forall \xi \in \mathbb{R}^N, \quad a(x)\xi \cdot \xi &\geq \gamma_* |\xi|^2 \end{aligned} \tag{2.12}$$

$$\mathbf{b}, \mathbf{c} \in (L^N(\Omega) + L^\infty(\Omega))^N \text{ if } N \geq 3 \tag{2.13}$$

$$\mathbf{b}, \mathbf{c} \in (L^{p_1}(\Omega) + L^\infty(\Omega))^N \text{ for some } p_1 > 2, \text{ if } N = 2 \tag{2.14}$$

$$V_0 \in L^1_{\text{loc}}(\Omega), \quad V_0 \geq 0 \tag{2.15}$$

The following is a special case of Gårding’s inequality (see, for instance, G. Stampacchia [13], or K. Yosida [16]):

Lemma 2.1. *Assume that the coefficients $a, \mathbf{b}, \mathbf{c}$ and V_0 satisfy (2.12)–(2.15), then there exists $\omega_0 \geq 0$ such that the operator $L + \omega_0 I$ satisfies, for all $\varphi \in C_c^\infty(\Omega)$,*

$$\langle (L + \omega_0 I)\varphi, \varphi \rangle = \langle L\varphi, \varphi \rangle + \omega_0 \|\varphi\|_2^2 \geq \frac{\gamma_*}{2} \|\nabla\varphi\|_2^2 + \int_\Omega V_0(x)\varphi(x)^2 dx. \quad (2.16)$$

When $N \geq 3$, denoting by c_* the best constant in the Sobolev inequality $\|\varphi\|_{2^*} \leq c_* \|\nabla\varphi\|_2$, and writing $\mathbf{c} - \mathbf{b} = \mathbf{b}_1 + \mathbf{b}_0$ with $\mathbf{b}_1 \in (L^\infty(\Omega))^N$ and $\mathbf{b}_0 \in (L^N(\Omega))^N$, the parameter ω_0 depends only on γ_* , $\|\mathbf{b}_1\|_\infty$ and on $\lambda > 0$ such that $c_* \|\mathbf{b}_0 \mathbf{1}_{\{|\mathbf{b}_0| > \lambda\}}\|_N < \gamma_*/4$.

Proof. Assume that $N \geq 3$. For $\varphi \in C_c^\infty(\Omega)$ we have

$$\langle L\varphi, \varphi \rangle = \int_\Omega a(x)\nabla\varphi(x) \cdot \nabla\varphi(x) dx + \int_\Omega V_0(x)\varphi(x)^2 dx + E_1, \quad (2.17)$$

where E_1 is defined to be

$$\begin{aligned} E_1 &:= \int_\Omega \varphi(x)(\mathbf{c}(x) - \mathbf{b}(x)) \cdot \nabla\varphi(x) dx \\ &= \int_\Omega \varphi(x) \mathbf{b}_0(x) \cdot \nabla\varphi(x) dx + \int_\Omega \varphi(x) \mathbf{b}_1(x) \cdot \nabla\varphi(x) dx. \end{aligned}$$

Since we assume that $\mathbf{c} - \mathbf{b} = \mathbf{b}_1 + \mathbf{b}_0$ with $\mathbf{b}_1 \in (L^\infty(\Omega))^N$ and $\mathbf{b}_0 \in (L^N(\Omega))^N$, upon applying Hölder’s inequality and using the Sobolev inequality $\|\varphi\|_{2^*} \leq c_* \|\nabla\varphi\|_2$, we can write for any $\lambda > 0$:

$$\begin{aligned} |E_1| &\leq \int_{\{|\mathbf{b}_0| > \lambda\}} |\mathbf{b}_0(x)| |\nabla\varphi(x)| |\varphi(x)| dx + (\lambda + \|\mathbf{b}_1\|_\infty) \|\nabla\varphi\|_2 \|\varphi\|_2 \\ &\leq c_* \|\mathbf{b}_0 \mathbf{1}_{\{|\mathbf{b}_0| > \lambda\}}\|_N \|\nabla\varphi\|_2^2 + (\lambda + \|\mathbf{b}_1\|_\infty) \|\nabla\varphi\|_2 \|\varphi\|_2 \\ &\leq (c_* \|\mathbf{b}_0 \mathbf{1}_{\{|\mathbf{b}_0| > \lambda\}}\|_N + \varepsilon) \|\nabla\varphi\|_2^2 + \frac{1}{4\varepsilon} (\lambda + \|\mathbf{b}_1\|_\infty)^2 \|\varphi\|_2^2. \end{aligned}$$

Therefore, using this in (2.17), we obtain

$$\langle L\varphi, \varphi \rangle \geq (\gamma_* - \gamma(\varepsilon, \lambda)) \|\nabla\varphi\|_2^2 - \omega(\varepsilon, \lambda) \|\varphi\|_2^2 + \int_\Omega V_0(x)\varphi(x)^2 dx,$$

where we have set

$$\gamma(\varepsilon, \lambda) := c_* \|\mathbf{b}_0 \mathbf{1}_{\{|\mathbf{b}_0| > \lambda\}}\|_N + \varepsilon, \quad \omega(\varepsilon, \lambda) := \frac{1}{4\varepsilon} (\lambda + \|\mathbf{b}_1\|_\infty)^2.$$

Since we have

$$\lim_{\lambda \rightarrow \infty} \|\mathbf{b}_0 \mathbf{1}_{\{|\mathbf{b}_0| > \lambda\}}\|_N = 0,$$

upon fixing $\lambda := \lambda_0 > 0$ large enough so that

$$c_* \|\mathbf{b}_0 \mathbf{1}_{\{|\mathbf{b}_0| > \lambda_0\}}\|_N < \frac{\gamma_*}{4}$$

and then taking $\varepsilon := \varepsilon_0 := \gamma_*/4$, we have $\gamma(\varepsilon_0, \lambda_0) < \gamma_*/2$. The result of the lemma follows with $\omega_0 := \omega(\varepsilon_0, \lambda_0)$.

The proof of the lemma in the case $N = 2$ is analogous, the only difference being that instead of the Sobolev inequality one has to use the Gagliardo–Nirenberg inequality $\|\varphi\|_{p'} \leq c_* \|\varphi\|_2^\theta \|\nabla\varphi\|_2^{1-\theta}$ where $p' = 2/\theta < \infty$ and $0 < \theta < 1$, while p is chosen so that $1 < p < p_1$. □

Remark 2.2. Note that when $N = 2$, or when $N \geq 3$ and $\mathbf{c} - \mathbf{b} := \mathbf{b}_0 + \mathbf{b}_1$ with $\mathbf{b}_1 \in (L^\infty(\Omega))^N$ and $\mathbf{b}_0 \in (L^{p_1}(\Omega))^N$, for some $p_1 > N$, one may prove that ω_0 depends only on γ_* and the norms $\|\mathbf{b}_1\|_\infty$ and $\|\mathbf{b}_0\|_{p_1}$. Indeed, with the notations of the above proof we have $\text{meas}(\{|\mathbf{b}_0| > \lambda\}) \leq \lambda^{-p_1} \|\mathbf{b}_0\|_{p_1}^{p_1}$, and so

$$\begin{aligned} \|\mathbf{b}_0 1_{\{|\mathbf{b}_0| > \lambda\}}\|_N &\leq (\text{meas}(\{|\mathbf{b}_0| > \lambda\}))^{(p_1 - N)/N p_1} \|\mathbf{b}_0\|_{p_1} \\ &\leq \lambda^{-(p_1 - N)/N} \|\mathbf{b}_0\|_{p_1}^{p_1/N}. \end{aligned}$$

Therefore one sees that in order to have

$$c_* \|\mathbf{b}_0 1_{\{|\mathbf{b}_0| > \lambda_0\}}\|_N < \frac{\gamma_*}{4},$$

it is enough to choose $\lambda := \lambda_0 > 0$ large enough so that

$$c_* \lambda_0^{-(p_1 - N)/N} \|\mathbf{b}_0\|_{p_1}^{p_1/N} < \frac{\gamma_*}{4},$$

and clearly λ_0 depends only on γ_* , c_* and $\|\mathbf{b}_0\|_{p_1}$. Consequently ω_0 depends only on γ_* , c_* , $\|\mathbf{b}_0\|_{p_1}$ and $\|\mathbf{b}_1\|_\infty$.

Remark 2.3. When the operator L is of the form

$$Lu := -\text{div}(a\nabla u) + \text{div}(\mathbf{b}u) + \mathbf{c} \cdot \nabla u + V_0 u - Vu,$$

where $V \in L^{N/2}(\Omega) + L^\infty(\Omega)$ and $V \geq 0$, while $a, \mathbf{b}, \mathbf{c}$ and V_0 are as in Lemma 2.1, one can show that for some $\omega_0 \in \mathbb{R}$ and all $\varphi \in C_c^\infty(\Omega)$ one has

$$\langle L\varphi + \omega_0, \varphi \rangle \geq \frac{\gamma_*}{2} \int_\Omega |\nabla\varphi(x)|^2 dx + \int_\Omega V_0(x)\varphi(x)^2 dx. \tag{2.18}$$

Indeed the only extra term in $\langle L\varphi, \varphi \rangle$ is

$$E_2 := - \int_\Omega V(x)\varphi(x)^2 dx,$$

which can be bounded, upon assuming that $V = V_1 + V_2$ with $V_1 \in L^{N/2}(\Omega)$ and $V_2 \in L^\infty(\Omega)$, by

$$|E_2| \leq (\lambda + \|V_2\|_\infty) \|\varphi\|_2^2 + c_*^2 \|V_1 1_{\{V_1 > \lambda\}}\|_{N/2} \|\nabla\varphi\|_2^2.$$

Therefore, using the estimates obtained in the proof of Lemma 2.1, one sees that

$$\langle L\varphi, \varphi \rangle \geq (\gamma_* - \tilde{\gamma}(\varepsilon, \lambda)) \|\nabla\varphi\|_2^2 - \tilde{\omega}(\varepsilon, \lambda) \|\varphi\|_2^2 + \int_\Omega V_0(x)\varphi(x)^2 dx,$$

where we have set

$$\begin{aligned} \tilde{\gamma}(\varepsilon, \lambda) &:= c_*^2 \|V_1 1_{\{|V_1|>\lambda}\}\|_{N/2} + c_* \|b_0 1_{\{|b_0|>\lambda}\}\|_N + \varepsilon \\ \tilde{\omega}(\varepsilon, \lambda) &:= \lambda + \|V_2\|_\infty + \frac{1}{4\varepsilon} (\lambda + \|b_1\|_\infty)^2. \end{aligned}$$

It is clear that for $\lambda > 0$ large enough (2.18) follows. Note also that when $V_1 \in L^q(\Omega)$ for some $q > N/2$, the parameter ω_0 depends only on γ_* , c_* , $\|b_0\|_{p_1}$, $\|b_1\|_\infty$, $\|V_1\|_q$ and $\|V_2\|_\infty$.

Remark 2.4. Since $\exp(-tL) = e^{\omega_0 t} \exp(-t(L + \omega_0 I))$, as far as we are concerned with the ultracontractivity and regularizing properties of the heat semigroup $\exp(-tL)$, at the cost of replacing V_0 by $V_0 + \omega_0$, there is no loss of generality in assuming that L satisfies

$$\text{for all } \varphi \in C_c^\infty(\Omega), \quad \langle L\varphi, \varphi \rangle \geq \frac{\gamma_*}{2} \|\nabla\varphi\|_2^2 + \int_\Omega V_0(x)\varphi(x)^2 dx. \tag{2.19}$$

and by a density argument we can assume that

$$\langle Lu, u \rangle \geq \frac{\gamma_*}{2} \|\nabla u\|_2^2 + \int_\Omega V_0(x)u(x)^2 dx$$

for all $u \in H_0^1(\Omega)$ such that $\int_\Omega V_0(x)|u(x)|^2 dx < \infty$.

In order to show that the heat semigroup $S(t) := \exp(-tL)$ generated by L is ultracontractive, we shall need a further assumption on the coefficient \mathbf{c} : in our approach this assumption is needed in order to show that $S(t)$ can be regarded as a continuous semigroup on $L^1(\Omega)$.

Lemma 2.5. *Assume that assumptions (2.12)–(2.15) are satisfied and that moreover for some $\omega_1 \in \mathbb{R}$ one has*

$$\operatorname{div}(\mathbf{c}) \leq \omega_1 + V_0 \quad \text{in the sense of } \mathfrak{D}'(\Omega). \tag{2.20}$$

Then for all $u_0 \in L^1(\Omega)$ and $t > 0$ one has

$$\|S(t)u_0\|_1 \leq e^{\omega_1 t} \|u_0\|_1.$$

Proof. Consider an initial data $u_0 \in D(L) \cap L^1(\Omega)$ which has a compact support and $u_0 \geq 0$, and assume first that Ω is bounded and $V_0 \in L^1(\Omega)$. Then if $\omega \geq \omega_1$ and $u(t)$ satisfies Dirichlet boundary conditions and is solution to

$$\partial_t u - \operatorname{div}(a\nabla u) + \operatorname{div}(\mathbf{b}u) + \mathbf{c} \cdot \nabla u + (\omega + V_0)u = 0, \quad u(0) = u_0, \tag{2.21}$$

we have $u(t, x) \geq 0$ and $u \in C^1([0, \infty), L^2(\Omega))$. Thanks to the fact that $u(t, \cdot) \geq 0$ in Ω while $u(t, \cdot) = 0$ on the boundary $\partial\Omega$ and to the assumption (2.12) we have that $(a\nabla u) \cdot \mathbf{n} \leq 0$ on $\partial\Omega$. Therefore, integrating (2.21) over Ω , after an integration by parts we have that

$$\frac{d}{dt} \int_\Omega u(t, x) dx \leq \frac{d}{dt} \int_\Omega u(t, x) dx - \langle \operatorname{div}(\mathbf{c}), u(t, \cdot) \rangle + \int_\Omega (\omega + V_0(x))u(t, x) dx \leq 0,$$

which means that

$$\int_{\Omega} u(t, x) dx \leq \int_{\Omega} u_0(x) dx.$$

For the general case, that is when Ω is unbounded or V_0 is only in $L^1_{\text{loc}}(\Omega)$, denote by $(\Omega_n)_n$ an increasing sequence of Lipschitz open subsets of Ω such that $\Omega_n \subset \subset \Omega_{n+1} \subset \subset \Omega$ and $\Omega = \cup_{n \geq 1} \Omega_n$. Now for n large enough so that $\text{supp}(u_0) \subset \Omega_n$, denoting by $u^{(n)}$ the corresponding solution of (2.21) on Ω_n , with $u^{(n)}(t, \cdot) = 0$ on $\partial\Omega_n$, we have $u^{(n)}(t, \cdot) \leq u^{(n+1)}(t, \cdot)$, thanks to the parabolic maximum principle. One can easily see that $u^{(n)}(t, \cdot) \uparrow u(t, \cdot)$ as $n \rightarrow \infty$, and since $\int_{\Omega} u^{(n)}(t, x) dx$ is bounded by $\int_{\Omega} u_0(x) dx$, by the monotone convergence theorem it converges to $\int_{\Omega} u(t, x) dx$ and finally we have that

$$\int_{\Omega} u(t, x) dx = \lim_{n \rightarrow +\infty} \int_{\Omega} u^{(n)}(t, x) dx \leq \int_{\Omega} u_0(x) dx.$$

By a density argument we see that the result of the lemma holds for all nonnegative $u_0 \in L^1(\Omega)$. For a general data $u_0 \in L^1(\Omega)$, upon writing $u_0 = u_0^+ - u_0^-$, it is easy to conclude the proof. \square

Remark 2.6. In particular Lemma 2.2 means that if $\omega \geq \omega_1$ and $u(t)$ satisfies Dirichlet boundary conditions and is solution to

$$\partial_t u + Lu + \omega u = 0, \quad u(0) = u_0,$$

then for $t > 0$ we have $\|u(t)\|_1 \leq \|u_0\|_1$. Note also that the (formal) adjoint of L being defined by

$$L^* u = -\text{div}(a^* \nabla u) - \text{div}(\mathbf{c} u) - \mathbf{b} \cdot \nabla u + V_0 u,$$

if we assume that $-\text{div}(\mathbf{b}) \leq \omega_2 + V_0$ in $\mathfrak{D}'(\Omega)$, then according to the above lemma we have

$$\| \exp(-tL^*) u_0 \|_1 \leq e^{\omega_2 t} \| u_0 \|_1.$$

Therefore if one assumes that $\omega \geq \omega_2$ and $v(t)$ satisfies Dirichlet boundary conditions and is solution to

$$\partial_t v + L^* v + \omega v = 0, \quad v(0) = u_0,$$

then for $t > 0$ we have $\|v(t)\|_1 \leq \|u_0\|_1$.

Next we show the ultracontractivity of the heat semigroup $\exp(-tL)$.

Lemma 2.7. *Let L be defined by (2.11) and let the assumptions (2.12)–(2.15) be satisfied. Assume moreover that for some $\omega_1, \omega_2 \in \mathbb{R}$ we have*

$$\text{div}(\mathbf{c}) \leq \omega_1 + V_0 \quad \text{and} \quad -\text{div}(\mathbf{b}) \leq \omega_2 + V_0 \quad \text{in the sense of } \mathfrak{D}'(\Omega). \quad (2.22)$$

Then the semigroup $S(t) := \exp(-tL)$ is ultracontractive, more precisely there exists a constant $c > 0$ depending only on γ_ such that if $\omega := \max(\omega_0, \omega_1, \omega_2)$, for $1 \leq s \leq r \leq \infty$ and all $t > 0$ and $u_0 \in L^s(\Omega)$ one has*

$$\|S(t)u_0\|_r \leq ct^{-\beta} e^{\omega t} \|u_0\|_s \quad \text{where } \beta := \frac{N}{2} \left(\frac{1}{s} - \frac{1}{r} \right). \quad (2.23)$$

Proof. Let $u_0 \in L^1(\Omega) \cap D(L)$ be given and let $u(t) := e^{-\omega t} e^{-tL} u_0$ be the solution of

$$\partial_t u + Lu + \omega u = 0, \quad u(0) = u_0.$$

Note that since $\omega \geq \omega_1$, thanks to Lemma 2.2 we have $\|u(t)\|_1 \leq \|u_0\|_1$. Then if we define $\varphi(t) := \|u(t)\|_2^2$, we have

$$\varphi'(t) = -2(Lu + \omega u|u).$$

Now, since according to Lemma 2.1 we have $(Lu + \omega u|u) \geq \gamma_* \|\nabla u\|_2^2/2$, using Nash's inequality $\|u\|_2^{(2N+4)/N} \leq c \|\nabla u\|_2^2 \|u\|_1^{4/N}$ (where $c > 0$ is a constant depending only on N), we conclude that

$$\begin{aligned} \|u(t)\|_2^{(2N+4)/N} &\leq \frac{2c}{\gamma_*} (Lu(t) + \omega u(t)|u(t)) \|u(t)\|_1^{4/N} \\ &\leq \frac{2c}{\gamma_*} (Lu(t) + \omega u(t)|u(t)) \|u_0\|_1^{4/N}, \end{aligned}$$

where in the last step we have used the fact that $\|u(t)\|_1 \leq \|u_0\|_1$. Finally we have

$$-\varphi'(t) = 2(Lu + \omega u|u) \geq \gamma_* \left(c \|u_0\|_1^{4/N}\right)^{-1} \varphi(t)^{(N+2)/N}$$

that is

$$\frac{d}{dt} \varphi(t)^{-2/N} \geq \frac{2\gamma_*}{N} \left(c \|u_0\|_1^{4/N}\right)^{-1},$$

and after an integration over the interval $[0, t]$ one sees that for some constant c_1 depending only on γ_* we have

$$\|u(t)\|_2 \leq c_1 t^{-N/4} \|u_0\|_1.$$

This means that $\|\exp(-tL)u_0\|_2 \leq c_1 e^{\omega t} t^{-N/4} \|u_0\|_1$. On the other hand the (formal) adjoint of L is given by

$$L^*u = -\operatorname{div}(a^* \nabla u) - \operatorname{div}(\mathbf{c} u) - \mathbf{b} \cdot \nabla u + V_0 u,$$

and since (2.22) holds, we may also conclude that Lemma 2.2 holds for the semigroup $\exp(-tL^*)$, and, arguing as above, we have that $\exp(-tL^*)$ maps $L^1(\Omega)$ into $L^2(\Omega)$ and in fact

$$\|\exp(-tL^*)u_0\|_2 \leq c_1 e^{\omega t} t^{-N/4} \|u_0\|_1.$$

From this, by duality, we infer that $\exp(-tL)$ maps $L^2(\Omega)$ into $L^\infty(\Omega)$, that is

$$\|\exp(-tL)u_0\|_\infty \leq c_1 e^{\omega t} t^{-N/4} \|u_0\|_2.$$

Therefore, since $\exp(-tL) = S(t) = S(t/2)S(t/2)$ we conclude that for some constant $c > 0$ depending only on γ_* we have

$$\|S(t)u_0\|_\infty \leq c e^{\omega t} t^{-N/2} \|u_0\|_1,$$

which means that the semigroup $S(t)$ is ultracontractive. Finally noting that

$$\|S(t)u_0\|_1 \leq \|u_0\|_1 \quad \text{and} \quad \|S^*(t)u_0\|_1 \leq \|u_0\|_1,$$

one sees that $\|S(t)u_0\|_\infty \leq \|u_0\|_\infty$ and (2.23) follows by interpolation. \square

Our aim is the proof of regularity results for solutions to the elliptic equation

$$\begin{cases} -\operatorname{div}(a\nabla u) + \operatorname{div}(\mathbf{b}u) + \mathbf{c} \cdot \nabla u + V_0u &= Vu + f & \text{in } \Omega \\ u &= 0 & \text{on } \partial\Omega, \end{cases} \tag{2.24}$$

where the coefficients $a, \mathbf{b}, \mathbf{c}$ and the potential V_0 satisfy the assumptions (2.12)–(2.15) and (2.22), while $V \in L^q(\Omega) + L^\infty(\Omega)$ is a nonnegative potential with $q > N/2$.

Since we have some information on the norm $\|u\|_r$ for some $r \geq 1$ (for instance if $u \in H_0^1(\Omega)$, then $r = 2^*$ if $N \geq 3$, or any finite r if $N = 2$), we can write equation (2.24) in the form

$$\begin{cases} Lu &= Vu + \omega u + f & \text{in } \Omega \\ u &= 0 & \text{on } \partial\Omega. \end{cases} \tag{2.25}$$

where, for $\omega := \max(\omega_0, \omega_1, \omega_2)$, the elliptic operator L is defined to be

$$Lu := -\operatorname{div}(a\nabla u) + \operatorname{div}(\mathbf{b}u) + \mathbf{c} \cdot \nabla u + V_0u + \omega u, \tag{2.26}$$

with a domain $D(L)$ which is defined as being

$$D(L) := \left\{ u \in H_0^1(\Omega) ; \int_{\Omega} V_0(x)u(x)^2 dx < \infty, \text{ and } Lu \in L^2(\Omega) \right\}.$$

In this way the new operator L satisfies the coercivity condition

$$\begin{aligned} \forall u \in H_0^1(\Omega) \text{ such that } \int_{\Omega} V_0(x)|u(x)|^2 dx < \infty, \\ \langle Lu, u \rangle \geq \frac{\gamma_*}{2} \|\nabla u\|^2 + \int_{\Omega} V_0(x)u(x)^2 dx \end{aligned} \tag{2.27}$$

and finally what we have just proved boils down to the following proposition:

Proposition 2.8. *Let $\Omega \subset \mathbb{R}^N$ be a locally Lipschitz domain and assume that the coefficients $a, \mathbf{b}, \mathbf{c}$ and V_0 satisfy conditions (2.12)–(2.15), and (2.22). Let L be defined by (2.26) and $\omega := \max(\omega_0, \omega_1, \omega_2)$, then the heat semigroup $S(t) := \exp(-tL)$ satisfies the following properties:*

1. For any $r \in [1, \infty]$, $S(t)$ is a contraction on $L^r(\Omega)$, that is $\|S(t)f\|_r \leq \|f\|_r$.
2. For $1 \leq s \leq r \leq \infty$ there exists a constant $k_0(s, r) > 0$ such that for any $t > 0$ and $f \in L^s(\Omega)$ one has

$$\|S(t)f\|_r \leq k_0(s, r)t^{-\beta} \|f\|_s, \quad \text{with } \beta := \frac{N}{2} \left(\frac{1}{s} - \frac{1}{r} \right),$$

where $k_0(s, r) := (k_0(1, \infty))^\theta$ and $\theta := 2\beta/N$, and $k_0(1, \infty)$ depends only on γ_* . Moreover when $L = -\Delta + V_0$ one may take $k_0(1, \infty) = (4\pi)^{-N/2}$.

Remark 2.9. There are many other cases for which $\exp(-tL)$ is an ultracontractive semi-group, in particular situations in which the underlying L^p spaces are weighted Lebesgue spaces (see for instance [10] where operators of the form $Lu := -\operatorname{div}(K\nabla u)$ are considered in Lebesgue spaces $L^p(\mathbb{R}^N, K(x)dx)$ with the weight $K(x) := \exp(\pm k(x))$ and $k(x) \geq 0$ having different type of behaviour as

$|x| \rightarrow \infty$). See also [9] for the case of a semigroup shown to be ultracontractive in a situation in which the weight is different in each of the L^p spaces under consideration. In these situations the parameter N in the definition of β is not necessarily the *dimension* of $\Omega \subset \mathbb{R}^N$ and may be any positive real number. There are also cases in which one may show that the semigroup $\exp(-tL)$ is ultracontractive, even though there is no maximum principle (this is the case for instance for the Stokes semigroup acting on divergence free vector valued functions defined on \mathbb{R}^N). In such cases, one can show regularity results for solutions of elliptic equations such as $Lu = f$, exactly as we do in the next sections but the parameter N and the norms of Lebesgue spaces should be replaced appropriately. \square

In a few occasions we may be led to use the following interpolation theorem of Marcinkiewicz-Zygmund (see for instance M. Cotlar & R. Cignoli [4, chapter VI, theorem 3.1.2], or E.M. Stein [14, Appendix B]). For $1 \leq p \leq \infty$ let $M^p(\Omega)$ denote the Marcinkiewicz (or weak- L^p) space, that is the class of measurable functions f such that for some fixed constant k and for all $\lambda > 0$ one has

$$\text{meas}(\{|f| > \lambda\}) \leq k^p \lambda^{-p}.$$

The lower bound on all such k 's is not a norm but is equivalent to the norm of $M^p(\Omega)$, which is defined as

$$\|f\|_{M^p(\Omega)} := \sup \left\{ \text{meas}(E)^{-(p-1)/p} \int_E |f(x)| dx ; E \text{ measurable, } E \subset \Omega \right\}.$$

Theorem 2.10 (Marcinkiewicz-Zygmund Theorem). *Let, for $j = 1, 2$, the linear (or sub-linear) operator B map continuously $L^{p_j}(\Omega)$ into $M^{r_j}(\Omega)$ with a norm denoted by b_j , where $1 \leq p_j \leq r_j \leq \infty$. Then if $r_2 \neq r_1$, and if for $0 < \theta < 1$ we set*

$$\frac{1}{p} = \frac{1-\theta}{p_1} + \frac{\theta}{p_2}, \quad \frac{1}{r} = \frac{1-\theta}{r_1} + \frac{\theta}{r_2},$$

B maps continuously $L^p(\Omega)$ into $L^r(\Omega)$ with a norm b bounded by $b \leq c(r_1, r, r_2) \cdot b_1^{1-\theta} b_2^\theta$ where

$$c(r_1, r, r_2) := \left(\frac{2r}{r-r_1} + \frac{2r}{r_2-r} \right)^{1/r}.$$

3. L^p regularity of solutions of elliptic equations

We assume that

$$\text{the elliptic operator } L \text{ is such that Proposition 2.4 holds,} \tag{3.1}$$

and we consider $u \in H_0^1(\Omega)$ solution to the equation

$$\begin{cases} Lu = Vu + f & \text{in } \Omega \\ u = 0 & \text{on } \partial\Omega, \end{cases} \tag{3.2}$$

where $f \in L^{q_0}(\Omega)$ and $V \in L^q(\Omega) + L^\infty(\Omega)$ for some $q > N/2$. As we pointed out in § 1, we write this equation in the form

$$u = S(t)u + \int_0^t S(t - \tau)Vu \, d\tau + \int_0^t S(t - \tau)f \, d\tau,$$

and we see that in order to obtain regularity results via the ultracontractivity of the heat semigroup, assuming that f is in a certain class of functions, the main point is to estimate terms such as $\int_0^t S(t - \tau)f \, d\tau$, or $\int_0^t S(t - \tau)Vu \, d\tau$ in various norms. To this end we denote by B_t and M_t the linear operators defined by:

$$B_t(f) := \int_0^t S(t - \tau)f \, d\tau = \int_0^t S(\tau)f \, d\tau \tag{3.3}$$

$$M_t(V, u) = \int_0^t S(t - \tau)Vu \, d\tau = \int_0^t S(\tau)Vu \, d\tau = B_t(Vu), \tag{3.4}$$

and we study the boundedness of these operators in appropriate L^p spaces.

We begin by establishing the continuity of B_t as an operator mapping $L^{q_0}(\Omega)$ into certain $L^r(\Omega)$, where the range of admissible r 's depends on q_0 .

Lemma 3.1. *For $q_0 > N/2$ and $q_0 \leq r \leq \infty$ there exists a constant $c_1(q_0, r) > 0$ depending only on γ_* such that for all $f \in L^{q_0}(\Omega)$ we have $B_t(f) \in L^r(\Omega)$ for $t > 0$ and*

$$\|B_t(f)\|_r \leq c_0(q_0, r) t^{1-\beta_0} \|f\|_{q_0}, \quad \text{with } \beta_0 := \frac{N}{2} \left(\frac{1}{q_0} - \frac{1}{r} \right) < 1. \tag{3.5}$$

Proof. Indeed by property 2. of Proposition 2.4 we have that

$$\|B_t(f)\|_r \leq \int_0^t \|S(\tau)f\|_r \, d\tau \leq k_0(q_0, r) \int_0^t \tau^{-\beta_0} \, d\tau \|f\|_{q_0},$$

which yields the lemma, provided $\beta_0 < 1$, which is the case when $q_0 > N/2$. □

Remark 3.2. When Ω is sufficiently smooth and for instance $L := -\Delta + V_0$, one can show that if $f \in L^{q_0}(\Omega)$, for $\tau > 0$ one has $S(\tau)f \in C_0(\overline{\Omega})$, and so for any $\varepsilon > 0$ with $\varepsilon < t$ the integral $g_\varepsilon := \int_\varepsilon^t S(\tau)f \, d\tau \in C_0(\overline{\Omega})$. As $\varepsilon \rightarrow 0^+$ (while $t > 0$ is fixed), one checks easily that $g_\varepsilon \rightarrow B_t(f)$ in L^∞ norm, provided one assumes $q_0 > N/2$, and so $B_t(f) \in C_0(\overline{\Omega})$. □

In the next lemma we treat the *critical* case $q_0 = N/2$, that is we study the operator B_t on $L^{N/2}(\Omega)$.

Lemma 3.3. *Assume that $N/2 \leq r < \infty$. Then there exists a constant $c_1(r) > 0$ depending only on γ_* so that if $f \in L^{q_0}(\Omega)$ with $q_0 = N/2$, we have $B_t(f) \in L^r(\Omega)$ for $t > 0$ and*

$$\|B_t(f)\|_r \leq c_2(r) t^{1-\beta_0} \|f\|_{N/2}, \quad \text{with } \beta_0 := 1 - \frac{N}{2r} < 1. \tag{3.6}$$

More precisely, there exist two positive constants $\mu_ := N/(2k_0(N/2, \infty))$ depending only on N and γ_* , and c_* , depending only on N , such that for $0 < \mu < \mu_*$ and*

$t > 0$,

$$\int_{\Omega} \left[\exp\left(\frac{\mu|B_t(f)(x)|}{\|f\|_{N/2}}\right) - \sum_{0 \leq k \leq [N/2]} \frac{1}{k!} \left(\frac{\mu|B_t(f)(x)|}{\|f\|_{N/2}}\right)^k \right] dx \leq \frac{c_*}{\mu_* - \mu} t^{N/2}. \tag{3.7}$$

Proof. Since B_t is linear, without loss of generality, we can assume that $\|f\|_{N/2} = 1$. Let $\alpha > 1$ be a parameter which will be fixed later on, and set

$$g := \int_0^{t/\alpha} S(\tau)f \, d\tau, \quad h := \int_{t/\alpha}^t S(\tau)f \, d\tau, \quad v := B_t(f) = g + h. \tag{3.8}$$

We have, using the fact that $S(\tau)$ maps $L^{N/2}(\Omega)$ into $L^\infty(\Omega)$, with a norm not greater than $k_0(N/2, \infty)\tau^{-1}$:

$$\|h\|_\infty \leq k_0(N/2, \infty) \int_{t/\alpha}^t \tau^{-1} \|f\|_{N/2} d\tau = k_0(N/2, \infty) \log \alpha. \tag{3.9}$$

Now, for $\lambda > 0$ given, we may fix $\alpha > 1$ such that $\lambda/2 = k_0(N/2, \infty) \log \alpha$, that is we may set

$$\alpha := \exp\left(\frac{2\mu_*\lambda}{N}\right), \quad \text{with } \mu_* := \frac{N}{2k_0(N/2, \infty)}.$$

This implies that $\|h\|_\infty \leq \lambda/2$. Since we have $v = g + h$, clearly $\{|v| > \lambda\} \subset \{|g| > \lambda/2\}$ and therefore

$$\text{meas}(\{|v| > \lambda\}) \leq \text{meas}(\{|g| > \lambda/2\}) \leq \left(\frac{\lambda}{2}\right)^{-N/2} \|g\|_{N/2}^{N/2}.$$

Using the fact that $S(\tau)$ is a contraction on $L^{N/2}(\Omega)$, we have $\|g\|_{N/2} \leq t\alpha^{-1}\|f\|_{N/2} = t\alpha^{-1}$, and henceforth with the above choice of α :

$$\text{meas}(\{|B_t(f)| > \lambda\}) = \text{meas}(\{|v| > \lambda\}) \leq (2t)^{N/2} \lambda^{-N/2} \exp(-\mu_*\lambda). \tag{3.10}$$

Recall that $\|v\|_{N/2} = \|B_t(f)\|_{N/2} \leq t\|f\|_{N/2} = t$, and that if $r > N/2$ is finite we have

$$\begin{aligned} \int_{\Omega} |v(x)|^r dx &= r \int_0^\infty \lambda^{r-1} \text{meas}(\{|v| > \lambda\}) d\lambda \\ &\leq (2t)^{N/2} r \int_0^\infty \lambda^{r-1} \lambda^{-N/2} \exp(-\mu_*\lambda) d\lambda = c(r, N)t^{N/2}. \end{aligned}$$

This proves that $\|B_t(f)\|_r \leq c(r, N)t^{N/2r}\|f\|_{N/2} = c(r, N)t^{N/2r}$ when $N/2 \leq r < \infty$, that is (3.6).

In order to see that the more precise estimate (3.7) holds, assuming that $\|f\|_{N/2} = 1$, denote by $[m]$ the integer part of $m > 0$ and for $s \geq 0$ set

$$G(s) := \exp(\mu s) - \sum_{k=0}^{[N/2]} \frac{\mu^k s^k}{k!}.$$

Since $G(s) \geq 0$ and $G'(s) \geq 0$ on $(0, \infty)$, using (3.10) we have

$$\begin{aligned} \int_{\Omega} G(|v(x)|) dx &= \int_0^\infty G'(\lambda) \text{meas}(\{|v| > \lambda\}) d\lambda \\ &\leq (2t)^{N/2} \int_0^\infty \lambda^{-N/2} \exp(-\mu_* \lambda) G'(\lambda) d\lambda \\ &\leq \frac{c_*(N)}{\mu_* - \mu} t^{N/2}, \end{aligned}$$

where we have used the fact that $\mu < \mu_*$ and that $0 \leq e^s - \sum_{k=0}^{n-1} s^k/k! \leq c(n)s^n e^s$, for $s \geq 0$ and any integer $n \geq 1$. □

Remark 3.4. After having obtained the estimate (3.10), in order to prove (3.6) we could have used the Marcinkiewicz-Zygmund interpolation theorem. Indeed it is clear that for $r \geq N/2$ there exists a constant $c(r, N)$ such that for all $s > 0$ we have $s^{-N/2} \exp(-Ns/4) \leq c(r, N)s^{-r}$, where as a matter of fact

$$c(r, N) := ((4r - 2N)/N)^{(2r-N)/2} \exp(-(2r - N)/2).$$

Finally it follows that for $N/2 \leq r < \infty$ we have

$$\|B_t(f)\|_{M^r(\Omega)} \leq c(r, N)^{1/r} (2t)^{N/2r} \|f\|_{N/2}.$$

This means that B_t maps continuously $L^{N/2}(\Omega)$ into the Marcinkiewicz space $M^{r_j}(\Omega)$ for any r_0, r_1 satisfying $N/2 \leq r_0 < r_1 < \infty$. Using the Marcinkiewicz-Zygmund interpolation theorem (with $p_0 = p_1 = N/2$ and for some $N/2 \leq r_0 < r < r_1 < \infty$), we conclude that $B_t : L^{N/2}(\Omega) \rightarrow L^r(\Omega)$ is a continuous operator for $N/2 \leq r < \infty$, with a norm as stated in the lemma. However the previous proof is rather more elementary. □

Remark 3.5. In the estimate (3.7), since for $N/2 \leq r \leq (N + 2)/2$ we have $B_t(f) \in L^r(\Omega)$, the term under the integral sign on the left hand side can be replaced by

$$\exp\left(\frac{\mu|B_t(f)(x)|}{\|f\|_{N/2}}\right) - \sum_{0 \leq k < N/2} \frac{1}{k!} \left(\frac{\mu|B_t(f)(x)|}{\|f\|_{N/2}}\right)^k,$$

in which case the right hand side of (3.7) would be replaced by $c(N) \max(t, t^{N/2}/(\mu_* - \mu))$. Note also that when Ω has finite measure one can just say that for $0 < \mu < \mu_*$, the function $\exp(\mu|B_t(f)|/\|f\|_{N/2})$ belongs to $L^1(\Omega)$. □

Remark 3.6. It is well known that the result of Lemma 3.2 is optimal. Indeed if $\Omega := B(0, e)$ and $u(x) := \log(|\log(|x|)|)$, then $-\Delta u = f$ where

$$f(x) := \frac{1}{|x|^2(\log|x|)^2} - \frac{N-2}{|x|^2 \log(|x|)}.$$

Clearly $f \in L^{q_0}(\Omega)$ (with $q_0 := N/2$), but $u \notin L^\infty(\Omega)$. □

Next we consider the case of the subcritical exponent $q_0 < N/2$. By the Sobolev imbedding theorems it is well known that if Ω is sufficiently smooth one has $W^{2,q_0}(\Omega) \subset L^{q_0^{**}}(\Omega)$ where

$$\frac{1}{q_0^{**}} := \frac{1}{q_0} - \frac{2}{N}.$$

If one knew that the solution $u \in H_0^1(\Omega)$ of $Lu = f$ belongs to $W^{2,q_0}(\Omega)$ then the following result would have been a consequence of the above mentioned Sobolev imbedding. However when the coefficients $a, \mathbf{b}, \mathbf{c}$ are non smooth, in general the solution u does not have any *better* regularity (in terms of Sobolev spaces) than belonging to $H_0^1(\Omega)$. In this sense the fact that $u \in L^{q_0^{**}}(\Omega)$ has to be proved directly.

Lemma 3.7. *For $1 < q_0 < N/2$ and $q_0 \leq r \leq q_0^{**}$, where we have set $q_0^{**} := q_0 N / (N - 2q_0)$, there exists a constant $c_2(q_0, r)$ such that for $f \in L^{q_0}(\Omega)$ we have $B_t(f) \in L^r(\Omega)$ for $t > 0$ and*

$$\|B_t(f)\|_r \leq c_2(q_0, r) t^{1-\beta_0} \|f\|_{q_0}, \quad \text{with } \beta_0 := \frac{N}{2} \left(\frac{1}{q_0} - \frac{1}{r} \right) \leq 1. \quad (3.11)$$

Proof. It is clear that for $1 \leq r < q_0^{**}$ we have

$$\|B_t(f)\|_r \leq k_0(q_0, r) \int_0^t \tau^{-\beta_0} d\tau \|f\|_{q_0} \quad \text{with } \beta_0 := \frac{N}{2} \left(\frac{1}{q_0} - \frac{1}{r} \right) < 1,$$

and this yields (3.11).

The proof of the limiting case $r = q_0^{**}$ is more delicate. Let q be any number such that $1 < q < N/2$. We begin by showing that B_t maps $L^q(\Omega)$ into the Marcinkiewicz space $M^{q^{**}}(\Omega)$, with $q^{**} := qN / (N - 2q)$, and then we apply the interpolation Theorem 2.5.

For a fixed q such that $1 < q < N/2$, assuming $\|f\|_q = 1$, we write again, as in (3.8), for $\alpha > 0$

$$v := B_t(f) := g + h \quad \text{where } g := \int_0^{\min(t,t/\alpha)} S(\tau)f d\tau, \quad h := \int_{\min(t,t/\alpha)}^t S(\tau)f d\tau. \quad (3.12)$$

(Note that if $\alpha \leq 1$ then $h \equiv 0$). One easily sees that

$$\|g\|_q \leq \int_0^{\min(t,t/\alpha)} \|S(\tau)f\|_q d\tau \leq \int_0^{\min(t,t/\alpha)} \|f\|_q d\tau = \min(t, t/\alpha),$$

and also clearly we have $h \in L^\infty(\Omega)$ and if $\alpha > 1$

$$\|h\|_\infty \leq \int_t^\infty \|S(\tau)f\|_\infty d\tau \leq k_0(q, \infty) \int_{t/\alpha}^\infty \tau^{-N/2q} d\tau =: c(q, N) \left(\frac{t}{\alpha} \right)^{(2q-N)/2q}.$$

If a given $\lambda > 0$ is so that there exists $\alpha > 1$ satisfying $\lambda/2 = c(q, N)(t/\alpha)^{(2q-N)/2q}$, i.e. if

$$\alpha_* := t \left(\frac{\lambda}{2c(q, N)} \right)^{2q/(N-2q)} > 1,$$

then we choose $\alpha := \alpha_*$ so that we have $\|h\|_\infty \leq \lambda/2$ and since $\min(t, t/\alpha_*) = t/\alpha_*$

$$\|g\|_q \leq c \frac{t}{\alpha_*} = c \lambda^{-2q/(N-2q)} = c \lambda^{-2q/(N-2q)}.$$

Otherwise, that is if the number α_* defined above is not greater than one, we have $h \equiv 0$ and $t \leq (\lambda/2c(q, N))^{-2q/(N-2q)}$, so finally in this case for a constant $c > 0$ depending on q, N we have

$$\|g\|_q \leq ct \leq c \lambda^{-2q/(N-2q)}.$$

In both cases, whatever the value of α_* may be, using the fact that $\{|v| > \lambda\} \subset \{|g| > \lambda/2\}$, we have

$$\text{meas}(\{|v| > \lambda\}) \leq \text{meas}(\{|g| > \lambda/2\}) \leq 2^q \lambda^{-q} \|g\|_q^q \leq c \lambda^{-Nq/(N-2q)} = c \lambda^{-q^{**}}.$$

This means that $\|v\|_{M^{q^{**}}(\Omega)} \leq c(q, N) \|f\|_q$, that is for any $1 < q < N/2$ the linear operator B_t is continuous from $L^q(\Omega)$ into $M^{q^{**}}(\Omega)$. Upon taking $1 < q_1 < q_0 < q_2 < N/2$, we have that $B_t : L^{q_j}(\Omega) \rightarrow M^{q_j^{**}}(\Omega)$ is continuous for $j = 1, 2$, and therefore using the Marcinkiewicz-Zygmund interpolation Theorem 2.5, we conclude that if $0 < \theta < 1$ is such that

$$\frac{1}{q_0} = \frac{1-\theta}{q_1} + \frac{\theta}{q_2}$$

then B_t maps continuously $L^{q_0}(\Omega)$ into $L^r(\Omega)$ where

$$\frac{1}{r} := \frac{1-\theta}{q_1^{**}} + \frac{\theta}{q_2^{**}} = \frac{1}{q_0^{**}},$$

and the proof of the lemma is done. □

Remark 3.8. It is noteworthy to observe that if we denote $B_\infty(f) := \int_0^\infty S(\tau)f \, d\tau$, the same procedure yields that if $f \in L^{q_0}(\Omega)$ then $B_\infty(f) \in L^{q_0^{**}}(\Omega)$ and as a matter of fact $\|B_\infty(f)\|_{q_0^{**}} \leq c \|f\|_{q_0}$. Indeed, for $1 < q < N/2$ and $f \in L^q(\Omega)$, upon setting:

$$v := B_\infty(f) := g + h \quad \text{where} \quad g := \int_0^t S(\tau)f \, d\tau, \quad h := \int_t^\infty S(\tau)f \, d\tau,$$

one easily sees that h is well defined and $h \in L^\infty(\Omega)$:

$$\|h\|_\infty \leq \int_t^\infty \|S(\tau)f\|_\infty \, d\tau \leq k_0(q, \infty) \int_t^\infty \tau^{-N/2q} \, d\tau =: c(q, N) t^{(2q-N)/2q}.$$

For a given $\lambda > 0$ choose $t > 0$ so that $\lambda/2 = c(q, N) t^{(2q-N)/2q}$, i.e.

$$t := c \lambda^{2q/(2q-N)},$$

so that we have $\|h\|_\infty \leq \lambda/2$ and $\|g\|_q \leq c(q, N) t = c(q, N) \lambda^{2q/(2q-N)}$. As before noting that $\{|v| > \lambda\} \subset \{|g| > \lambda/2\}$, and

$$\text{meas}(\{|v| > \lambda\}) \leq \text{meas}(\{|g| > \lambda/2\}) \leq 2^q \lambda^{-q} \|g\|_q^q \leq c \lambda^{-Nq/(N-2q)} = c \lambda^{-q^{**}},$$

and the reader is convinced that the remainder of the argument is exactly as above.

Now we consider a potential V and for a given function u and $t > 0$ we denote by $M_t(V, u)$ the operator

$$M_t(V, u) := \int_0^t S(\tau)Vu \, d\tau. \tag{3.13}$$

We are going to state in which functional spaces M_t is well defined and what are the assumptions needed to impose on V and u .

Lemma 3.9. *Let $N \geq 3$ and $V \in L^q(\Omega)$ for some $q \in (N/2, \infty]$. Let $r_0 \in (1, \infty)$ be such that*

$$\frac{1}{s_0} := \frac{1}{q} + \frac{1}{r_0} < 1.$$

Then for $t > 0$, the operator $u \mapsto M_t(V, u)$ maps $L^{r_0}(\Omega)$ into $L^{r_1}(\Omega)$, with:

- (i) $s_0 \leq r_1 \leq \infty$, if $s_0 > N/2$;
- (ii) $N/2 \leq r_1 < \infty$, if $s_0 = N/2$;
- (iii) $s_0 \leq r_1 \leq s_0^{**}$, if $1 < s_0 < N/2$.

More precisely, there exists a constant $c_3(r_0, q, r_1)$ depending on γ_ such that*

$$\|M_t(V, u)\|_{r_1} \leq c_3(r_0, q, r_1) t^{1-\beta} \|V\|_q \|u\|_{r_0}, \quad \text{with } \beta := \frac{N}{2} \left(\frac{1}{s_0} - \frac{1}{r_1} \right) < 1.$$

Proof. With the above definition of s_0 it is enough to notice that $Vu \in L^{s_0}(\Omega)$ by Hölder inequality and that $\|Vu\|_{s_0} \leq \|V\|_q \|u\|_{r_0}$. Hence, according to the value of s_0 with respect to $N/2$ using either of the Lemmas 3.1, 3.2 or 3.3 we have that

$$\|M_t(V, u)\|_{r_1} \leq \int_0^t \|S(\tau)Vu\|_{r_1} \leq c t^{1-\beta} \|Vu\|_{s_0} \leq c t^{1-\beta} \|V\|_q \|u\|_{r_0},$$

where $\beta = (N/2s_0) - (N/2r_1)$. □

Remark 3.10. Note that if $Vu \in L^{N/2}(\Omega)$, then according to Lemma 3.2 we have $M_t(V, u) = B_t(Vu) \in L^r(\Omega)$ for all $r \in [N/2, \infty)$, and in fact some functional of $|M_t(V, u)|$, having an exponential growth at infinity, is in $L^1(\Omega)$. The same is true if $Vu \in L^{s_0}(\Omega)$ for some $s_0 > N/2$, since Lemma 3.1 implies that $M_t(V, u) \in L^\infty(\Omega) \cap L^{s_0}(\Omega)$.

In the case of dimension $N = 2$, if we assume that $V \in L^q(\Omega)$ for some $q > 1$, then for any $u \in H_0^1(\Omega)$ we have $Vu \in L^{s_0}(\Omega)$ for any $1 < s_0 < q$, since by the Sobolev imbedding theorem we have $u \in L^{r_0}(\Omega)$ for any $r_0 \in [2, \infty)$ (to see this just define $s_0^{-1} := q^{-1} + r_0^{-1}$). Therefore in this case we have immediately $M_t(V, u) \in L^{r_1}(\Omega)$ for any $r_1 \in [s_0, \infty]$, and according to Lemma

$$\|M_t(V, u)\|_{r_1} \leq c t^{1-\beta} \|V\|_q \|u\|_{r_0},$$

where with $\beta := s_0^{-1} - r_1^{-1} = q^{-1} + r_0^{-1} - r_1^{-1} < 1$. □

We will need the following lemma in which a certain (finite) sequence of pairs (s, r) is constructed in order to use a bootstrap argument later on.

Lemma 3.11. *Let $N \geq 3$ and $q > N/2$ be given and denote by $r_0 > q'$ a finite positive number. Define s_0 and $\delta > 0$ by*

$$\frac{1}{s_0} := \frac{1}{q} + \frac{1}{r_0} < 1, \quad \delta := \frac{2}{N} - \frac{1}{q} > 0.$$

Then there exist a finite integer $m \geq 1$ and a sequence (s_k, r_k) for $0 \leq k \leq m$ defined by the following procedure:

(i) *If $s_k < N/2$, then set*

$$\frac{1}{r_{k+1}} := \frac{1}{s_k^{**}} := \frac{1}{s_k} - \frac{2}{N} = \frac{1}{r_k} - \delta, \quad \frac{1}{s_{k+1}} := \frac{1}{q} + \frac{1}{r_{k+1}}.$$

(ii) *If $s_k = N/2$, then set $m := k + 1$ and $r_{k+1} \in (\delta^{-1}, \infty)$ is any finite number larger than $1/\delta$ and*

$$\frac{1}{s_{k+1}} := \frac{1}{q} + \frac{1}{r_{k+1}} < \frac{2}{N}.$$

(iii) *If $s_k > N/2$ then set $m := k + 1$ and $(s_{k+1}, r_{k+1}) := (q, \infty)$.*

Proof. The only point to verify in this lemma is that after a finite number of steps one has indeed $s_k \geq N/2$. This is clear since whenever $s_k < N/2$ then

$$\frac{1}{s_{k+1}} = \frac{1}{q} + \frac{1}{r_{k+1}} = \frac{1}{s_k} - \delta,$$

and therefore, since $\delta > 0$ is fixed, after a finite number of steps m one has $s_{k+1} \geq N/2$ (actually m is the smallest integer larger than $(\delta r_0)^{-1}$). \square

Now we are in a position to prove a regularity result concerning solutions of general elliptic equations.

Theorem 3.12. *Let the coefficients $a, \mathbf{b}, \mathbf{c}$ and V_0 satisfy the conditions (2.12)–(2.15) and (2.22). Assume that $u \in H_0^1(\Omega)$ solves*

$$-\operatorname{div}(a\nabla u) + \operatorname{div}(\mathbf{b}u) + \mathbf{c} \cdot \nabla u + V_0 u = Vu + f, \tag{3.14}$$

and that

$$V \in L^q(\Omega) + L^\infty(\Omega), \quad f \in L^{q_0}(\Omega),$$

with $\min(q, q_0) > N/2$. Then $u \in L^\infty(\Omega)$ and there exist positive constants c, c_0 depending on q, q_0 and polynomially on $t > 0$ such that:

$$\|u\|_\infty \leq c(t^{-1})\|\nabla u\|_2 + c_0(t)\|f\|_{q_0}. \tag{3.15}$$

Proof. We give the details of the proof for the case $N \geq 3$, since the case $N = 2$ is handled in much the same way. We write

$$V = V_1 + V_2 \quad \text{where} \quad V_1 \in L^q(\Omega) \quad \text{and} \quad V_2 \in L^\infty(\Omega). \tag{3.16}$$

Let $\omega := \max(\omega_0, \omega_1, \omega_2)$ and denote by $S(t)$ the heat semigroup generated by $u \mapsto Lu$ where

$$Lu := -\operatorname{div}(a\nabla u) + \operatorname{div}(\mathbf{b}u) + \mathbf{c} \cdot \nabla u + V_0 u + \omega u,$$

and write the equation (3.14) in the form $v(t, x) := u(x)$

$$\partial_t v + Lv = Vv + \omega v + f, \quad v(0, x) = u(x), \quad v(t, \sigma) = 0 \text{ on } \partial\Omega,$$

so that $u = v$ is solution to the mild version of this evolution equation, that is

$$\begin{aligned} u &= S(t)u + \int_0^t S(\tau)(V_1 u + (\omega + V_2)u + f) d\tau \\ &= S(t)u + M_t(V_1, u) + M_t(\omega + V_2, u) + B_t(f), \end{aligned} \tag{3.17}$$

where B_t and M_t are defined in (3.3) and (3.13) respectively. Since $u \in H_0^1(\Omega)$, we have that $S(t)u$ is in $L^r(\Omega)$ for $2^* \leq r \leq \infty$ and following Proposition 2.4 (with $(s, r) := (2^*, r)$):

$$\|S(t)u\|_r \leq k_0(2^*, r)t^{-\alpha} \|u\|_{2^*}, \quad \text{with } \alpha := \alpha(r) := \frac{N}{2} \left(\frac{1}{2^*} - \frac{1}{r} \right). \tag{3.18}$$

In the same manner, using Lemma 3.1 we have

$$\|B_t(f)\|_r \leq c(q_0, r)t^{1-\gamma_1} \|f\|_{q_0}, \quad \text{with } \gamma_1 := \gamma_1(r) := \frac{N}{2} \left(\frac{1}{q_0} - \frac{1}{r} \right) < 1. \tag{3.19}$$

Since $V_2 \in L^\infty(\Omega)$, if we have $u \in L^{r_k}(\Omega)$ for some $r_k > N/2$ (this is so for instance when $N \leq 5$ with $k = 0$, that is $r_0 := 2^*$, given that $u \in H_0^1(\Omega) \subset L^{2^*}(\Omega)$), noting that $M_t(\omega + V_2, u) = B_t((\omega + V_2)u)$ and $(\omega + V_2)u \in L^{r_0}(\Omega)$, by Lemma 3.1 we may assert that $M_t(\omega + V_2, u) \in L^r(\Omega)$ for $N/2 < r_k \leq r \leq \infty$ and

$$\|M_t(\omega + V_2, u)\|_r \leq c(r_k, r)t^{1-\gamma_3} (\omega + \|V_2\|_\infty) \|u\|_{r_k}, \quad \text{with } \gamma_3 := \frac{N}{2} \left(\frac{1}{r_k} - \frac{1}{r} \right) < 1. \tag{3.20}$$

Analogously, if $u \in L^{r_k}(\Omega)$ and $r_k = N/2$, then $(\omega + V_2)u \in L^{r_k}(\Omega)$ and according to Lemma 3.2 for $N/2 \leq r < \infty$ we have

$$\|M_t(\omega + V_2, u)\|_r \leq c(r_k, r)t^{1-\gamma_3} (\omega + \|V_2\|_\infty) \|u\|_{r_k}, \quad \text{with } \gamma_3 := 1 - \frac{N}{2r} < 1. \tag{3.21}$$

Finally if $u \in L^{r_k}(\Omega)$ and $1 < r_k < N/2$, then according to Lemma 3.3 for $N/2 \leq r \leq r_k^{**}$ we have

$$\|M_t(\omega + V_2, u)\|_r \leq c(r_k, r)t^{1-\gamma_3} (\omega + \|V_2\|_\infty) \|u\|_{r_k}, \quad \text{with } \gamma_3 := \frac{N}{2} \left(\frac{1}{r_k} - \frac{1}{r} \right) \leq 1. \tag{3.22}$$

Now it remains to estimate the term $M_t(V_1, u)$, and to this end we are going to use a bootstrap argument. In what follows we use the notations of Lemma 3.6, that is we consider the finite sequence $r_0 := 2^* < r_1 < \dots < r_m$. Assuming that $u \in L^{r_k}(\Omega)$ (which is the case for $k = 0$) thanks to Lemma 3.6 and Lemma 3.5, we conclude that $M_t(V_1, u) \in L^{r_{k+1}}(\Omega)$ and

$$\|M_t(V_1, u)\|_{r_{k+1}} \leq c(r_k, r_{k+1})t^{1-\beta} \|V_1\|_q \|u\|_{r_k}, \quad \text{with } \beta := \frac{N}{2} \left(\frac{1}{s_k} - \frac{1}{r_{k+1}} \right) < 1. \tag{3.23}$$

Next the equality (3.17) together with the estimates (3.18)–(3.22) (setting $r := r_{k+1}$) yield that $u \in L^{r_{k+1}}(\Omega)$ and that for some constant $c := c(r_k, r_{k+1}, q_0, q_1)$ we have

$$\begin{aligned} \|u\|_{r_{k+1}} \leq & c \left(t^{-\alpha(r_{k+1})} + t^{1-\gamma_3(r_{k+1})}(\omega + \|V_2\|_\infty) + t^{1-\beta(r_k, r_{k+1})}\|V_1\|_q \right) \|u\|_{r_k} \\ & + c t^{1-\gamma_1(r_{k+1})}\|f\|_{q_0}. \end{aligned} \tag{3.24}$$

It is clear that after a finite number of steps this argument shows that $u \in L^\infty(\Omega)$ and that the estimate (3.15) holds (actually as soon as one has $u \in L^{r_{k_0}}(\Omega)$ and $s_{k_0}^{-1} := q^{-1} + r_{k_0}^{-1} < N/2$ for some $k_0 \leq m$, then $V_1 u \in L^{s_{k_0}}(\Omega)$ and therefore $M_t(V_1, u) = B_t(Vu) \in L^\infty(\Omega)$, according to Lemma 3.1). \square

Theorem 3.13. *With the notations and assumptions of Theorem 3.7 on the coefficients $a, \mathbf{b}, \mathbf{c}$ and V_0, V , assume that $f \in L^{q_0}(\Omega)$ with $q_0 = N/2$. Then there exist $\mu_* > 0$ depending only on γ_* , and a constant $c > 0$ depending on $\omega, \|V_1\|_q, \|V_2\|_\infty$ and μ , such that for $0 < \mu < \mu_*$ one has*

$$\int_\Omega \left[\exp\left(\frac{\mu|u(x)|}{\|f\|_{N/2}}\right) - \sum_{0 \leq k \leq [N/2]} \frac{1}{k!} \left(\frac{\mu|u(x)|}{\|f\|_{N/2}}\right)^k \right] dx \leq c.$$

Proof. Assume that $\|f\|_{N/2} = 1$. The only change in the above proof is that the estimate (3.19) holds provided $r_0 \leq r < \infty$, and in fact since (3.18) and either of (3.20)–(3.22) hold for this range of the exponent r , the estimate (3.24) may be replaced by

$$\|u\|_r \leq c \left(t^{-\alpha(r)} + t^{1-\gamma_3(r)}(\omega + \|V_2\|_\infty) + t^{1-\beta(r_k, r)}\|V_1\|_q \right) \|u\|_{r_k} + c t^{1-\gamma_1(r)}\|f\|_{q_0}, \tag{3.25}$$

provided $r := r_{k+1}$ if $r_{k+1} < \infty$, or else any $r < \infty$. This yields that $u \in L^r(\Omega)$ for $\max(2, N/2) \leq r < \infty$.

Now, since $Vu \in L^s(\Omega)$ for some $s > N/2$ (in fact $s^{-1} := q^{-1} + r^{-1}$ for some large enough r), then Lemma 3.1 implies that $M_t(V, u) = B_t(Vu) \in L^r(\Omega)$ for all $s \leq r \leq \infty$. On the other hand, since $u \in L^2(\Omega)$, we have $Vu \in L^{2q/(q+2)}(\Omega)$ and so finally

$$M_t(V, u) \in L^\infty(\Omega) \cap L^2(\Omega), \quad \text{and} \quad S(t)u \in L^\infty(\Omega) \cap L^2(\Omega).$$

Now, μ_* being as in Lemma 3.2, for $0 < \mu < \mu_*$ and $s \geq 0$ denote by $G(s)$ the function

$$G(s) := \exp(\mu s) - \sum_{k=0}^{[N/2]} \frac{(\mu s)^k}{k!},$$

and set $z := S(t)u + M_t(V, u) \in L^\infty(\Omega)$. If $\lambda_0 := \lambda_0(t) := \|z\|_\infty$, then for $\lambda > 2\lambda_0$, since $u = z + B_t(f)$ and $\|z\|_\infty < \lambda/2$ we have $\{|u| > \lambda\} \subset \{|B_t(f)| > \lambda/2\}$. Also,

setting $n - 1 := [N/2]$, since $G(s) \leq c(\mu s)^n e^{\mu s}$ for $s \geq 0$, we have that

$$\begin{aligned} \int_0^{2\lambda_0} G'(\lambda) \text{meas}([|u| > \lambda]) \, d\lambda &\leq c \mu^n e^{2\mu\lambda_0} \int_0^{2\lambda_0} \lambda^n \text{meas}([|u| > \lambda]) \, d\lambda \\ &\leq c \mu^n e^{2\mu\lambda_0} \int_0^\infty \lambda^n \text{meas}([|u| > \lambda]) \, d\lambda \\ &= c \mu^n e^{2\mu\lambda_0} \|u\|_{n+1}^{n+1}. \end{aligned}$$

Therefore according to the estimate (3.10), and using the above estimate, we have

$$\begin{aligned} \int_\Omega G(|u(x)|) dx &= \int_0^\infty G'(\lambda) \text{meas}([|u| > \lambda]) \, d\lambda \\ &= \int_0^{2\lambda_0} G'(\lambda) \text{meas}([|u| > \lambda]) \, d\lambda + \int_{2\lambda_0}^\infty G'(\lambda) \text{meas}([|u| > \lambda]) \, d\lambda \\ &\leq c \mu^n e^{2\mu\lambda_0} \|u\|_{n+1}^{n+1} + c t^{N/2} \int_{2\lambda_0}^\infty \lambda^{-N/2} \lambda^n e^{-(\mu_* - \mu)\lambda} \, d\lambda \\ &\leq c \mu^n e^{2\mu\lambda_0} \|u\|_{n+1}^{n+1} + \frac{c}{\mu_* - \mu} t^{N/2}, \end{aligned}$$

and thus the theorem is proved. □

Remark 3.14. It is important to note that when $V \in L^{N/2}(\Omega) + L^\infty(\Omega)$, it is not anymore true that for $f \in L^{q_0}(\Omega)$ with $q_0 > N/2$ one has $u \in L^\infty(\Omega)$. For instance, for $N \geq 3$ let $\Omega := B(0, 1)$ and choose $\varphi \in C_0^\infty(\mathbb{R}^N)$ such that $0 \leq \varphi \leq 1$ and

$$\varphi(x) = \begin{cases} 1 & \text{for } |x| \leq 1/4 \\ 0 & \text{for } |x| \geq 3/4. \end{cases}$$

Then $u(x) := \varphi(x) \log(|x|)$ satisfies $u \in H_0^1(\Omega)$

$$-\Delta u = Vu + f,$$

with

$$V(x) := \frac{(N - 2)}{|x|^2 |\log(|x|)|}, \quad f(x) := (-\Delta\varphi) \log(|x|) - \frac{2x \cdot \nabla\varphi(x)}{|x|^2}.$$

Clearly $f \in C_c^\infty(\Omega)$ and $V \in L^{N/2}(\Omega)$ while $u \notin L^\infty(\Omega)$. For the case of L being essentially the Laplacian, a result due to H. Brezis & T. Kato [3] states that if $-\Delta u + V_0 u = Vu + f$, with $V \in L^{N/2}(\Omega) + L^\infty(\Omega)$ (and for instance $V \geq 0$, while V_0 is as in (2.15)), then if $f \in L^p(\Omega)$ for all $p \in [2, \infty)$, one has $u \in L^p(\Omega)$ for all $p \in [2, \infty)$. Unfortunately at this point we are unable to show this result using only the ultracontractivity of the underlying semigroup. □

4. The case of a data in divergence form

Let the coefficients $a, \mathbf{b}, \mathbf{c}$ and V_0 satisfy the conditions (2.12)–(2.15) and (2.22) and assume that $u \in H_0^1(\Omega)$ solves

$$-\text{div}(a\nabla u) + \text{div}(\mathbf{b}u) + \mathbf{c} \cdot \nabla u + V_0 u = Vu + f + \text{div}(\mathbf{g}), \tag{4.1}$$

and that

$$V \in L^q(\Omega) + L^\infty(\Omega), \quad f \in L^{q_0}(\Omega), \quad \mathbf{g} \in (L^{q_1}(\Omega))^N.$$

Then using the analyticity of heat semigroups such as $\exp(-tL)$ one can show regularity results for u . According to what we have already proved in the previous section, it is clear that we need only to study the regularity of the mapping

$$\mathbf{g} \mapsto \int_0^t S(\tau)(\operatorname{div}(\mathbf{g})) \, d\tau$$

from $L^{q_1}(\Omega)$ into some appropriate L^p space.

Under the assumptions and notations of Proposition 2.4 it is known that $\exp(-tL)$ and $\exp(-tL^*)$ are analytic groups on $(0, \infty)$ acting on $L^2(\Omega)$ (see for instance K. Yosida [16], or A. Pazy [12]), and that in particular for $t > 0$ and $u_0 \in L^2(\Omega)$ we have

$$u(t) := \exp(-tL)u_0 \in D(L) \quad \text{and} \quad v(t) := \exp(-tL^*)u_0 \in D(L^*),$$

and that one has the estimates

$$\|Lu(t)\|_2 \leq \frac{c}{t} \|u_0\|_2 \quad \text{and} \quad \|L^*v(t)\|_2 \leq \frac{c}{t} \|u_0\|_2.$$

Then using the coercivity property (2.27) we see that $\exp(-tL)$ and $\exp(-tL^*)$ are continuous linear operators from $L^2(\Omega)$ into $H_0^1(\Omega)$ and that

$$\|u(t)\|_{H_0^1(\Omega)}^2 \leq c \|Lu(t)\|_2 \|u(t)\|_2 \leq \frac{c}{t} \|u_0\|_2^2,$$

and analogously $\|v(t)\|_{H_0^1(\Omega)} \leq ct^{-1/2} \|u_0\|_2$. As a consequence we see that $\exp(-tL)$, and $\exp(-tL^*)$ are bounded operators mapping $H^{-1}(\Omega)$ into $L^2(\Omega)$ with a norm not greater than $ct^{-1/2}$, and in particular for any $\mathbf{g} \in (L^2(\Omega))^N$ we have

$$\|\exp(-tL)(\operatorname{div}(\mathbf{g}))\|_2 \leq ct^{-1/2} \|\mathbf{g}\|_2 \quad \text{and} \quad \|\exp(-tL^*)(\operatorname{div}(\mathbf{g}))\|_2 \leq ct^{-1/2} \|\mathbf{g}\|_2.$$

From this one can show that Proposition 2.4 can be completed with the following (see A. Pazy [12]):

Proposition 4.1. *Under the hypotheses of Proposition 2.4, for given $1 \leq s \leq r \leq \infty$, there exists a constant $k_1(s, r) = (k_1(1, \infty))^\theta > 0$ such that for $\mathbf{g} \in (L^s(\Omega))^N$ one has*

$$\|S(t)(\operatorname{div}(\mathbf{g}))\|_r \leq k_1(s, r)t^{-\beta} t^{-1/2} \|\mathbf{g}\|_s, \quad \text{with } \beta := \frac{N}{2} \left(\frac{1}{s} - \frac{1}{r} \right).$$

Lemma 4.2. *Assume that $\mathbf{g} \in (L^{q_1}(\Omega))^N$ for some $q_1 > N$. Then if $q_1 \leq r \leq \infty$ we have $B_t(\operatorname{div}(\mathbf{g})) \in L^r(\Omega)$ for $t > 0$ and*

$$\|B_t(\operatorname{div}(\mathbf{g}))\|_r \leq c(q_1, r) t^{(1-2\beta_1)/2} \|\mathbf{g}\|_{q_1}, \quad \text{where } \beta_1 := \frac{N}{2} \left(\frac{1}{q_1} - \frac{1}{r} \right) < \frac{1}{2}.$$

Proof. We use the semigroup property of $S(t)$ to write

$$B_t(\operatorname{div}(\mathbf{g})) = \int_0^t S(\tau/2)S(\tau/2)(\operatorname{div}(\mathbf{g})) \, d\tau.$$

Now by Proposition 4.1 we have

$$\|S(\tau/2)(\operatorname{div}(\mathbf{g}))\|_{q_1} \leq k_1(q_1)(\tau/2)^{-1/2}\|\mathbf{g}\|_{q_1},$$

and therefore applying Proposition 2.4, this time its property 2) with $(s, r) = (q_1, r)$ and f replaced with $S(\tau/2)\operatorname{div}(\mathbf{g})$:

$$\|B_t(\operatorname{div}(\mathbf{g}))\|_r \leq k_1(q_1)\sqrt{2}2^{\beta_1}k_0(q_1, r) \int_0^t \tau^{-\beta_1-\frac{1}{2}} \, d\tau \|\mathbf{g}\|_{q_1},$$

which yields the result of the lemma, provided $\beta_1 = (N/2q_1) - (N/2r) < 1/2$. \square

Remark 4.3. When Ω is sufficiently smooth and for instance $L := -\Delta + V_0$, one can show that if $\mathbf{g} \in (L^{q_1}(\Omega))^N$, for $\tau > 0$ one has $S(\tau/2)(\operatorname{div}(\mathbf{g})) \in L^{q_1}(\Omega)$ and that

$$S(\tau)(\operatorname{div}(\mathbf{g})) = S(\tau/2)S(\tau/2)(\operatorname{div}(\mathbf{g})) \in C_0(\overline{\Omega}),$$

and so for $0 < \varepsilon < t$ the integral $g_\varepsilon := \int_\varepsilon^t S(\tau)(\operatorname{div}(\mathbf{g})) \, d\tau \in C_0(\overline{\Omega})$. As $\varepsilon \rightarrow 0^+$ (while $t > 0$ is fixed), one checks easily that $g_\varepsilon \rightarrow B_t(\operatorname{div}(\mathbf{g}))$ in L^∞ norm, provided one assumes $q_1 > N$, and so $B_t(\operatorname{div}(\mathbf{g})) \in C_0(\overline{\Omega})$. \square

Next consider the *critical case* in which $\mathbf{g} \in (L^N(\Omega))^N$.

Lemma 4.4. *Assume that $\mathbf{g} \in (L^{q_1}(\Omega))^N$ with $q_1 := N$. Then for $N \leq r < \infty$ we have $B_t(\operatorname{div}(\mathbf{g})) \in L^r(\Omega)$ for all $t > 0$ and*

$$\|B_t(\operatorname{div}(\mathbf{g}))\|_r \leq c(r) t^{(1-2\beta_1)/2} \|\mathbf{g}\|_N, \quad \text{where } \beta_1 := \frac{1}{2} - \frac{N}{2r} < \frac{1}{2}. \tag{4.2}$$

More precisely, there exist two constants $\mu_ := N/(8k_1(N, \infty))$, depending only on N and γ_* , and c_* , depending only on N , such that for $0 < \mu < \mu_*$ and $t > 0$*

$$\int_\Omega \left[\exp\left(\frac{\mu|B_t(\operatorname{div}(\mathbf{g}))(x)|}{\|\mathbf{g}\|_N}\right) - \sum_{0 \leq k \leq N} \frac{1}{k!} \left(\frac{\mu|B_t(\operatorname{div}(\mathbf{g}))(x)|}{\|\mathbf{g}\|_N}\right)^k \right] dx \leq \frac{c_*}{\mu_* - \mu} t^N. \tag{4.3}$$

Proof. We follow the lines of the proof of Lemma 3.2. Assuming that $\|\mathbf{g}\|_N = 1$, let $\alpha > 1$ be a parameter which will be fixed later on, and set

$$f := \int_0^{t/\alpha} S(\tau)\operatorname{div}(\mathbf{g}) \, d\tau, \quad h := \int_{t/\alpha}^t S(\tau)\operatorname{div}(\mathbf{g}) \, d\tau, \quad v := B_t(\operatorname{div}(\mathbf{g})) = f + h. \tag{4.4}$$

Since for $(s, r) := (N, \infty)$ in Proposition 4.1 we have

$$\|S(\tau/2)(\operatorname{div}(\mathbf{g}))\|_\infty \leq 2\tau^{-1}k_1(N, \infty)\|\mathbf{g}\|_N = 2\tau^{-1}k_1(N, \infty),$$

we can write $h = \int_{t/\alpha}^t S(\tau/2)S(\tau/2)\operatorname{div}(\mathbf{g}) d\tau$ and hence

$$\|h\|_\infty \leq 2k_1(N, \infty) \int_{t/\alpha}^t \tau^{-1} \|\mathbf{g}\|_N d\tau = 2k_1(N, \infty) \log \alpha. \tag{4.5}$$

As we did above, for $\lambda > 0$ given we may fix $\alpha > 1$ such that $\lambda/2 = 2k_1(N, \infty) \log \alpha$, that is we may set

$$\alpha := \exp\left(\frac{2\mu_*\lambda}{N}\right), \quad \text{with } \mu_* := \frac{N}{8k_1(N, \infty)},$$

so that $\|h\|_\infty \leq \lambda/2$. Since $\{|v| > \lambda\} \subset \{|f| > \lambda/2\}$ we conclude that

$$\operatorname{meas}(\{|v| > \lambda\}) \leq \operatorname{meas}(\{|f| > \lambda/2\}) \leq \left(\frac{\lambda}{2}\right)^{-N} \|f\|_N^N.$$

Using the fact that by Proposition 4.1:

$$\|f\|_N \leq \int_0^{t/\alpha} \|S(\tau)(\operatorname{div}(\mathbf{g}))\|_N d\tau \leq k_1(N, N) \int_0^{t/\alpha} \tau^{-1/2} d\tau = k_1(N, N) \left(\frac{t}{\alpha}\right)^{1/2}$$

with the above choice of α we obtain

$$\operatorname{meas}(\{|v| > \lambda\}) \leq c t^{N/2} \lambda^{-N} \exp(-\mu_*\lambda). \tag{4.6}$$

Since by Proposition 4.1 we have $\|v\|_N = \|B_t(\operatorname{div}(\mathbf{g}))\|_N \leq k_1(N, N)t^{1/2}\|\mathbf{g}\|_N = k_1(N, N)t^{1/2}$, it remains to see that if $r > N$ is finite we have $B_t(\operatorname{div}(\mathbf{g})) \in L^r(\Omega)$. Indeed

$$\begin{aligned} \int_\Omega |v(x)|^r dx &= r \int_0^\infty \lambda^{r-1} \operatorname{meas}(\{|v| > \lambda\}) d\lambda \\ &\leq c t^{N/2} r \int_0^\infty \lambda^{r-N-1} \exp(-\mu_*\lambda) d\lambda = c(r, N) t^{N/2}. \end{aligned}$$

This proves that $\|B_t(\operatorname{div}(\mathbf{g}))\|_r \leq c(r, N) t^{N/2r} \|\mathbf{g}\|_N$ when $N < r < \infty$.

To obtain estimate (4.3), assuming that $\|\mathbf{g}\|_N = 1$, for $s \geq 0$ set

$$G(s) := \exp(\mu s) - \sum_{k=0}^N \frac{\mu^k s^k}{k!},$$

so that $G(s) \geq 0$ and $G'(s) \geq 0$ on $(0, \infty)$. Then using (4.6) we have

$$\begin{aligned} \int_\Omega G(|v(x)|) dx &= \int_0^\infty G'(\lambda) \operatorname{meas}(\{|v| > \lambda\}) d\lambda \\ &\leq c(N) t^{N/2} \int_0^\infty \lambda^{-N} \exp(-\mu_*\lambda) G'(\lambda) d\lambda \\ &\leq \frac{c_*(N)}{\mu_* - \mu} t^{N/2} \end{aligned}$$

where in the last step we have used the estimate $0 \leq e^s - \sum_{k=0}^N s^k/k! \leq c(N)s^{N+1}e^s$, for $s \geq 0$ and the fact that $\mu < \mu_*$. □

The *subcritical* case is considered in the next lemma.

Lemma 4.5. *Assume that $\mathbf{g} \in (L^{q_1}(\Omega))^N$ with $1 < q_1 < N$. Then for $q_1 \leq r \leq q_1^*$, where $q_1^* := Nq_1/(N - q_1)$, we have $B_t(\operatorname{div}(\mathbf{g})) \in L^r(\Omega)$ for $t > 0$ and*

$$\|B_t(\operatorname{div}(\mathbf{g}))\|_r \leq c(q_1, r) t^{(1-2\beta_1)/2} \|\mathbf{g}\|_{q_1}, \quad \text{where } \beta_1 := \frac{N}{2} \left(\frac{1}{q_1} - \frac{1}{r} \right) \leq \frac{1}{2}. \quad (4.7)$$

Proof. According to Proposition 4.1 it is clear that for $q_1 \leq r < q_1^*$ we have

$$\|B_t(\operatorname{div}(\mathbf{g}))\|_r \leq k_1(q_1, r) \int_0^t \tau^{-\beta_1} \tau^{-1/2} \|\mathbf{g}\|_{q_1} d\tau \quad \text{with } \beta_1 := \frac{N}{2} \left(\frac{1}{q_1} - \frac{1}{r} \right) < \frac{1}{2},$$

and this yields (4.7).

The proof of the limiting case $r = q_1^*$ is more delicate and follows the same lines of the proof of Lemma 3.3. We consider $1 < q < N$ and for some $\mathbf{g} \in (L^q(\Omega))^N$ we want to show that the operator $\mathbf{g} \mapsto B_t(\operatorname{div}(\mathbf{g}))$ is bounded from $(L^q(\Omega))^N$ into $M^{q^*}(\Omega)$. We write again, as in (4.4), assuming $\|\mathbf{g}\|_q = 1$,

$$v := B_t(\operatorname{div}(\mathbf{g})) := f + h$$

where for $\alpha > 0$ we have set

$$f := \int_0^{\min(t, t/\alpha)} S(\tau)(\operatorname{div}(\mathbf{g})) d\tau, \quad h := \int_{\min(t, t/\alpha)}^t S(\tau)(\operatorname{div}(\mathbf{g})) d\tau. \quad (4.8)$$

(Note that if $\alpha \leq 1$ then $h \equiv 0$). One easily sees that

$$\begin{aligned} \|f\|_N &\leq \int_0^{\min(t, t/\alpha)} \|S(\tau)(\operatorname{div}(\mathbf{g}))\|_N d\tau \\ &\leq c(N) \int_0^{\min(t, t/\alpha)} \tau^{-1/2} d\tau = c(\min(t, t/\alpha))^{1/2}, \end{aligned}$$

and that $h \in L^\infty(\Omega)$, and if $\alpha > 1$,

$$\begin{aligned} \|h\|_\infty &\leq \int_{t/\alpha}^\infty \|S(\tau)(\operatorname{div}(\mathbf{g}))\|_\infty d\tau \\ &\leq k_1(q, \infty) \int_{t/\alpha}^\infty \tau^{-N/2q} \tau^{-1/2} d\tau = c(q, N) \left(\frac{t}{\alpha} \right)^{(q-N)/2q}. \end{aligned}$$

If a given $\lambda > 0$ is so that there exists $\alpha > 1$ satisfying $\lambda/2 = c(q, N)(t/\alpha)^{(q-N)/2q}$, i.e. if

$$\alpha_* := t \left(\frac{\lambda}{2c(q, N)} \right)^{2q/(N-q)} > 1,$$

then we choose $\alpha := \alpha_*$ in such a way that we have $\|h\|_\infty \leq \lambda/2$ and

$$\|f\|_q \leq c(t\alpha^{-1})^{1/2} = c\lambda^{-q/(N-q)}.$$

Otherwise, that is if the number α_* defined above is not greater than one, we have $h \equiv 0$ and for some constant $c > 0$ depending on N, q we have $t \leq c\lambda^{-2q/(N-q)}$, so that finally

$$\|f\|_q \leq ct^{1/2} \leq c\lambda^{-q/(N-q)}.$$

In both cases, using the fact that $[|v| > \lambda] \subset [|f| > \lambda/2]$, we have

$$\text{meas}(|v| > \lambda) \leq \text{meas}(|f| > \lambda/2) \leq 2^q \lambda^{-q} \|f\|_q^q \leq c \lambda^{-Nq/(N-q)} = c \lambda^{-q^*}.$$

This means that $\|v\|_{M^{q^*}(\Omega)} \leq c(q, N) \|g\|_q$. Upon taking $1 < q_0 < q_1 < q_2 < N$, we have that $B_t : (L^{q_j}(\Omega))^N \rightarrow M^{q_j^*}(\Omega)$ for $j = 0$ and $j = 2$, is continuous, and therefore using the Marcinkiewicz-Zygmund interpolation Theorem 2.5, we conclude that if $0 < \theta < 1$ is such that

$$\frac{1}{q_1} = \frac{1-\theta}{q_0} + \frac{\theta}{q_2}$$

then B_t maps continuously $L^{q_1}(\Omega)$ into $L^r(\Omega)$ where

$$\frac{1}{r} := \frac{1-\theta}{q_0^*} + \frac{\theta}{q_1^*} = \frac{1}{q_1^*},$$

and the proof of the lemma is done. □

Remark 4.6. It is noteworthy to observe that if we denote $B_\infty(\text{div}(g)) := \int_0^\infty S(\tau)(\text{div}(g)) d\tau$, the same procedure yields that $B_\infty(\text{div}(g)) \in L^{q^*}(\Omega)$ and as a matter of fact $\|B_\infty(\text{div}(g))\|_{q^*} \leq c \|g\|_q$. Indeed assuming that $\|g\|_q = 1$, and upon setting:

$$v := B_\infty(\text{div}(g)) := f + h \quad \text{where}$$

$$f := \int_0^t S(\tau)(\text{div}(g)) d\tau, \quad h := \int_t^\infty S(\tau)(\text{div}(g)) d\tau,$$

one easily sees that h is well defined and $h \in L^\infty(\Omega)$: indeed according to Proposition 4.1 with $(s, r) := (q, \infty)$ we have

$$\begin{aligned} \|h\|_\infty &\leq \int_t^\infty \|S(\tau)(\text{div}(g))\|_\infty d\tau \\ &\leq k_1(q, \infty) \int_t^\infty \tau^{-1/2} \tau^{-N/2q} d\tau = c(q, N) t^{-(N-q)/2q}. \end{aligned}$$

For a given $\lambda > 0$ choose $t > 0$ so that $\lambda/2 = c(q, N) t^{-(N-q)/2q}$, i.e. set

$$t := \left(\frac{\lambda}{2c(q, N)} \right)^{-2q/(N-q)},$$

so that we have $\|h\|_\infty \leq \lambda/2$. On the other hand again by Proposition 4.1 we have

$$\|f\|_q \leq k_1(q, q) \int_0^t \tau^{-1/2} d\tau = c t^{1/2} = c \lambda^{-q/(N-q)}.$$

As before $[|v| > \lambda] \subset [|f| > \lambda/2]$, and

$$\text{meas}(|v| > \lambda) \leq \text{meas}(|f| > \lambda/2) \leq 2^q \lambda^{-q} \|f\|_q^q \leq c \lambda^{-Nq/(N-q)} = c \lambda^{-q^*},$$

and the reader is convinced that the remainder of the argument is exactly as above. □

References

- [1] D. Aronson, Bounds for fundamental solutions of a parabolic equation, *Bull. Amer. Math. Soc.* **73** (1967), 890–896.
- [2] P. Auscher, Regularity theorems and heat kernels for elliptic operators, *J. London Math. Soc.* (2) **54** (1996), 284–296.
- [3] H. Brezis and T. Kato, Remarks on the Schrödinger operator with complex potentials, *J. Math. Pures & Appl.* **58** (1979), n° 2, 137–151.
- [4] M. Cotlar and R. Cignoli, *An Introduction to Functional Analysis*, North-Holland Texts in Advanced Mathematics, Amsterdam, 1974.
- [5] Th. Coulhon, L. Saloff-Coste and N.T. Varopoulos, *Analysis and Geometry on Groups*, Cambridge Tracts in Mathematics # 100, Cambridge University Press, 1992.
- [6] E.B. Davies, *Heat Kernels and Spectral Theory*, Cambridge Tracts in Mathematics # **92**, Cambridge University Press, 1989.
- [7] E.B. Fabes and D.W. Strook, A new proof of Moser’s parabolic Harnack inequality via the old ideas of Nash, *Arch. Rat. Mech. Analysis* **96** (1986), 327–338.
- [8] M. Fukushima, On an L^p estimate of resolvents of Markov processes, *Research Inst. Math. Science, Kyoto Univ.* **13** (1977), 277–284.
- [9] O. Kavian, Remarks on the Kompaneets equation, a simplified model of the Fokker-Planck equation. In: *Nonlinear Partial Differential Equations and their Applications*, Collège de France Seminar, D. Cioranescu and J.L. Lions, editors, vol. 14, pp. 467–487. In *Studies in Mathematics and its Applications*, vol. 31, North-Holland Elsevier, July 2002.
- [10] O. Kavian, G. Kerkycharian and B. Roynette, Quelques remarques sur l’ultracontractivité, *J. of Functional Analysis*, **111** (1993), 155–196.
- [11] J. Nash, Continuity of solutions of parabolic and elliptic equations, *Amer. J. Math.* **80** (1958), 931–954.
- [12] A. Pazy, *Semigroups of Linear Operators and Applications to Partial Differential Equations*, vol. 44 of *Applied Mathematical Sciences series*, Springer, New York, 1983.
- [13] G. Stampacchia, *Équations Elliptiques du Second Ordre à Coefficients Discontinus*, Presses de l’Université de Montréal, série “Séminaires de Mathématiques Supérieures”, #16, Montréal, 1965.
- [14] E.M. Stein, *Singular Integral Operators and Differentiability of Functions*, Princeton University Press, Princeton, 1970.
- [15] N.Th. Varopoulos, Hardy-Littlewood theory for semigroups, *J. Func. Analysis* **63** (1985), 240–260.
- [16] K. Yosida, *Functional Analysis*, Springer-Verlag, “Die Grundlehren der Mathematischen Wissenschaften”, #123, New York, 1974.

Otared Kavian
Laboratoire de Mathématiques Appliquées
Université de Versailles
45 avenue des Etats Unis
78035 Versailles cedex
France
e-mail: kavian@math.uvsq.fr

2d Ladyzhenskaya–Solonnikov Problem for Inhomogeneous Fluids

Farid Ammar Khodja and Marcelo M. Santos

Abstract. We consider the Ladyzhenskaya–Solonnikov problem [5] for a stationary inhomogeneous incompressible fluid in a 2d domain. Given arbitrary fluxes for the velocity and momentum fields, we prove the existence of a weak solution.

Mathematics Subject Classification (2000). 35Q30, 76D05.

Keywords. Stationary Navier–Stokes equations, domain with an unbounded boundary, incompressible flow, inhomogeneous fluid.

1. Introduction

In this paper we consider a stationary inhomogeneous incompressible fluid in a domain $\Omega = \cup_{i=0}^2 \Omega_i$ of the plane with two infinity channels Ω_1 and Ω_2 (described more precisely below), where ‘inhomogeneous’ stands for variable density. The mass density, velocity, pressure and given constant viscosity of the fluid are denoted, respectively, by ρ , $\mathbf{v} = (v_1, v_2)$, p , and μ . The stationary Navier–Stokes equations describing such a fluid are the following:

$$\begin{cases} \mu \Delta \mathbf{v} = \rho(\mathbf{v} \cdot \nabla) \mathbf{v} + \nabla p \\ \nabla \cdot \mathbf{v} = 0, \quad \nabla \cdot (\rho \mathbf{v}) = 0. \end{cases} \quad (1)$$

The first equation represents the conservation of momentum and the second and third equations represent the incompressibility of the fluid and the conservation of mass, respectively. We solve (1) adjoined with any prescribed values for the fluxes of the velocity \mathbf{v} and momentum $\rho \mathbf{v}$ through the cross sections of Ω_1 and Ω_2 ; Theorem 1 below. Throughout the paper, we also assume the non slip boundary condition $\mathbf{v} = 0$ on $\partial\Omega$.

Inhomogeneous fluids are important to be investigated in both mathematical and physical aspects. They can model, for instance, stratified fluids (see e.g. [6])

and the meeting of fluids coming from different regions with distinct densities, e.g. sewerage, water-works, the meeting of two or more rivers, and junctions of channels as, for instance, occurs more recently in devices in the area of engineering called MEMS (Micro-Electro-Mechanical Systems). From the mathematical point of view, challenging questions are pertinent even for the case of a constant density. For instance, the solvability of the nonlinear Leray's problem under no restriction on the velocity flux through the cross sections of the channels is an important open question. It consists in finding a solution of (1), with ρ identically equal to a constant, such that \mathbf{v} tends to given Poiseuille flows (i.e. parallel flows) at large distances in the channels Ω_i , $i = 1, 2$. This, of course, makes sense only in the case that the channels Ω_1 and Ω_2 are straight. However, without the assumption of smallness on the velocity flux, up to now there is no proof of the existence of a solution for such problem. Assuming that the velocity flux is sufficiently small, it was proved by Amick [1] that Leray's problem admits a solution. Attempts have been made by important mathematicians to remove that assumption without success [4]. Leray's problem seems to have been proposed to Olga A. Ladyzhenskaya by Jean Leray in the 1950s; cf. [1, p. 476]. In [5], Ladyzhenskaya and V. A. Solonnikov change the problem proposing to find a solution of (1), still in the case of a constant density, such that the velocity field has a prescribed arbitrary flux through the cross sections of the channels, but not demanding that the velocity field tends to parallel flows at large distance in the channels. It happens that the problem formulated this way gains generality since it is not necessary the channels to be straight in order the problem make sense. Besides, they were able to prove the existence of a solution for such problem, for an arbitrary given velocity flux, and with the only restriction on the channels that they have bounded cross sections, from below and above. Furthermore, their solution recovers Amick's solution when the channels are straight and the velocity flux is sufficiently small. It remains an open question whether Ladyzhenskaya–Solonnikov's solution tends to a Poiseuille flow at large distances when the channels are straight and the velocity flux is not sufficiently small.

For inhomogeneous fluids, ρ not being a constant, Leray's problem was treated in [3]. As far as we know, Ladyzhenskaya–Solonnikov problem was not proposed for inhomogeneous fluid up to now. In this paper, we formulate and solve Ladyzhenskaya–Solonnikov problem for inhomogeneous fluid (1), given arbitrary value for the velocity flux and, which is a new issue, given arbitrary value for the momentum flux as well.

The restriction on the dimension, Ω a subset of the plane \mathbb{R}^2 , is essential for us, since our approach depends on the streamline formulation $\rho = \omega(\psi)$, $\mathbf{v} = \nabla^\perp \psi$, where $\omega \in C_b(\mathbb{R})$; see Notations below. To prove Theorem 1 we solve first (Theorem 2) the equation $\mu \Delta \mathbf{v} = \omega(\psi)(\mathbf{v} \cdot \nabla) \mathbf{v} + \nabla p$, $\mathbf{v} = \nabla^\perp \psi$, which is in fact a nonlinear equation for the biharmonic operator Δ^2 , since applying the *curl* operator to this equation ($\text{curl} = \partial_y - \partial_x$) it becomes $\mu \Delta^2 \psi = \text{curl}(\omega(\psi)(\mathbf{v} \cdot \nabla) \mathbf{v})$, $\mathbf{v} = \nabla^\perp \psi$. We use Amick's [1] and Ladyzhenskaya–Solonnikov's [5] ideas combined with Galerkin method. That is, write $\mathbf{v} = \mathbf{u} + \mathbf{a}$ where \mathbf{u} is the new unknown with zero flux and

\mathbf{a} is a special constructed function, depending only on the domain Ω , and with the given velocity flux. Then we cut the domain, use Galerkin method to solve the problem in the cut domain, and obtain very careful estimates with respect to the cut domain. We perform all estimates we need in details, yielding the explicit dependence on the L^∞ -norm of the density. To obtain a solution satisfying the given momentum flux, we take profit from the freedom of choice of ω . Specifically, we take $\omega \in C_b(\mathbb{R})$ such that $\int_{-\alpha}^0 \omega(s) ds = \beta$, where α and β are, respectively, the given velocity flux and momentum flux; see (40).

To end this section, we give below the main notations we shall use.

Notations:

- Γ : the boundary of Ω ;
- $W^{k,p}(\Omega)$: the Sobolev space of order k modeled in $L^p(\Omega)$;
- $W_0^{k,p}(\Omega)$: the space of functions in $W^{k,p}(\Omega)$ whose derivatives up to order $k - 1$ have null trace on Γ ;
- $H_k(\Omega)$: the space of functions in $W_0^{k,2}(\Omega)$ that are divergent free in Ω , i.e. $\nabla \cdot \mathbf{v} = 0$ in Ω ;
- $W_{loc}^{k,p}(\overline{\Omega})$: the space of functions in $W^{k,p}(\Omega')$ for any bounded open subset Ω' of Ω ;
- $H_{k,loc}(\overline{\Omega})$: the space of functions in $W^{k,2}(\Omega')$ for any bounded open subset Ω' of Ω that are divergent free and whose derivatives up to order $k - 1$ have null trace on Γ ;
- \mathcal{V} : the space of functions in $C^\infty(\Omega)$ with compact support in Ω and that are divergence free in Ω ;
- (\cdot, \cdot) : the inner product of $L^2(\Omega)$;
- $\nabla^\perp \psi$: the rotated gradient $\nabla^\perp = (-\partial_y, \partial_x)$ acting on a scalar function $\psi = \psi(x, y)$ defined in Ω ,
i.e. $\nabla^\perp \psi \stackrel{\text{def}}{=} (-\partial_y \psi, \partial_x \psi)$;
- $C_b(X)$: the space of functions defined on X that are continuous and bounded, where X is an open set of \mathbb{R}^n ,
endowed with the supremum norm $\|f\|_{C_b(X)} = \sup_{x \in X} |f(x)|$
- $C_b^\infty(X)$: $C^\infty(X) \cap C_b(X)$;
- c : some constant that does not depend on the unknowns.

The functions in the aforementioned spaces may be either scalar or vector-valued functions. We have that $H_k(\Omega)$ equals to the closure of \mathcal{V} in $W_0^{k,2}(\Omega)$, in virtue of the shape of our domain Ω , described precisely in Section 2. Besides, since Ω has dimension two and functions in $H_1(\Omega)$ vanish on Γ , we have also $H_1(\Omega) = \{\nabla^\perp \psi : \psi \in W^{2,2}(\Omega) \text{ and } \nabla \psi|_\Gamma = 0\}$.

Besides this introduction, this paper contains the next section in which we formulate and solve the Ladyzhenskaya–Solonnikov problem for equations (1).

2. 2d Ladyzhenskaya–Solonnikov problem for inhomogeneous fluids

In this section we formulate and solve the Ladyzhenskaya–Solonnikov problem for equations (1). We start describing precisely our domain Ω .

Let Ω be an open and simply connected set of the plane \mathbb{R}^2 with a smooth boundary, denoted by Γ , such that $\Omega = \cup_{i=0}^2 \Omega_i$, where Ω_0 is a bounded open set and, in possibly different cartesian coordinate systems,

$$\Omega_1 = \{(x, y) \in \mathbb{R}^2 : x < 0, -d_1(x) < y < d_1(x)\}$$

and

$$\Omega_2 = \{(x, y) \in \mathbb{R}^2 : x > 0, -d_2(x) < y < d_2(x)\}$$

with $d_i(x) > 0, i = 1, 2$, being smooth functions uniformly bounded with respect to x , from above and below.

Ladyzhenskaya–Solonnikov problem: To equations (1) we adjoin the non slip boundary condition

$$\mathbf{v} = 0 \quad \text{on } \partial\Omega \tag{2}$$

and the flux conditions for the velocity and momentum

$$\int_{\Sigma} v_1(x, y) dy = \alpha, \tag{3}$$

$$\int_{\Sigma} \rho v_1(x, y) dy = \beta, \tag{4}$$

where $\Sigma \equiv \Sigma(x)$ denotes the cross sections of Ω_i at x ($i = 1, 2$) i.e. $\Sigma(x) \stackrel{\text{def}}{=} \{(x, y) : -d_i(x) < y < d_i(x)\}$ ($x < 0$ if $i = 1$ and $x > 0$ if $i = 2$) and, α and β are given arbitrary constants in \mathbb{R} (see Remark 1 below).

We look for a weak solution of (1)–(4) according to the following definition.

Definition 1. A pair $(\rho, \mathbf{v}) \in C_b(\Omega) \times H_{1,loc}(\overline{\Omega})$ is said to be a weak solution of Problem (1)–(4) whenever

- i. (3) and (4) are satisfied in the trace sense;
- ii.

$$\int_{\Omega} \rho \mathbf{v} \cdot \nabla \varphi dx = 0, \tag{5}$$

for all φ in $C_0^\infty(\Omega)$ and

- iii.

$$\mu \int_{\Omega} \nabla \mathbf{v} \cdot \nabla \Phi dx = \int_{\Omega} \rho (\mathbf{v} \cdot \nabla \Phi) \cdot \mathbf{v} dx, \tag{6}$$

for all $\Phi = (\Phi_1, \Phi_2)$ in \mathcal{V} , where $\nabla \mathbf{v} \cdot \nabla \Phi \stackrel{\text{def}}{=} \nabla v_1 \cdot \nabla \Phi_1 + v_2 \cdot \nabla \Phi_2$ and $\mathbf{v} \cdot \nabla \Phi \stackrel{\text{def}}{=} (\mathbf{v} \cdot \nabla \Phi_1, \mathbf{v} \cdot \nabla \Phi_2)$.

Remark 1. If $\mathbf{v} \in W_{loc}^{1,2}(\overline{\Omega})$, it is classical that \mathbf{v} has a trace on the cross section $\Sigma \equiv \Sigma(x)$, for each $x \in \mathbb{R}$, so (3) is well defined in the trace sense for $\mathbf{v} \in H_{1,loc}(\overline{\Omega})$. The same conclusion holds true for the equation (4), but here we use that $\rho\mathbf{v}$ belongs to $L_{loc}^2(\overline{\Omega})$ and $\nabla \cdot \rho\mathbf{v} = 0$ in the sense of distributions (see (5)), then $\rho\mathbf{v}$ has a normal trace on each cross section Σ , see e.g. [7, Theorem I.1.2]. Moreover, since $\nabla \cdot \mathbf{v} = \nabla \cdot \rho\mathbf{v} = 0$, the fluxes $\int_{\Sigma} v_1(x, y) dy$ and $\int_{\Sigma} \rho v_1(x, y) dy$ are independent of x .

Equations (5) and (6) are just the weak formulations (in the sense of distributions) of the conservation of mass and momentum equations, respectively, i.e. multiply these equations by the test functions indicated in (5) and (6) and formally integrate by parts. Cf. [1, Def. 3.1]. In equation (6) the pressure p is canceled out because the (vector valued) test functions Φ are divergence free. It is classical that we can recover the pressure from (6); see e.g. [7, Propositions I.1.1 and I.1.2, p. 14]. The incompressibility equation is inserted in the space $\mathbf{H}_{1,loc}(\overline{\Omega})$.

Remark 2. As it is observed in [5], if α is different from zero and \mathbf{v} verifies the above definition, then the Dirichlet integral $\int_{\Omega} |\nabla \mathbf{v}|^2$ is infinite. In fact, it grows at least linearly with x ; indeed, from Hölder and Poincaré inequalities we have

$$\alpha^2 \leq 2d \int_{\Sigma} v_1(x, y)^2 dy \leq 2d^3 \int_{\Sigma} v_{1y}(x, y)^2 dy,$$

so

$$\alpha^2(x_2 - x_1) \leq 2d^3 \int_{x_1}^{x_2} \int_{\Sigma} v_{1y}(x, y)^2 dy dx.$$

Remark 3. We remark that when $\mathbf{v} = \nabla^{\perp} \psi$ and $\rho = \omega(\psi)$ for some $\psi \in W_{loc}^{2,2}(\overline{\Omega})$ and $\omega \in C_b(\mathbb{R})$, the equation $\nabla \cdot (\rho\mathbf{v}) = 0$ is automatically satisfied in the weak sense (i.e. we have (5)) if $\omega \in C_b(\mathbb{R})$ and $\psi \in W_{loc}^{2,2}(\overline{\Omega})$. Indeed, for a smooth ω , it is straightforward to obtain $\nabla \cdot (\omega(\psi)\nabla^{\perp} \psi) = 0$ in the classical sense, and for $\omega \in C_b(\mathbb{R})$, we can obtain the result by passing to the limit in (5) with $\rho = \omega^{\epsilon}(\psi)$ and $\mathbf{v} = \nabla^{\perp} \psi$, with ϵ tending to zero, where ω^{ϵ} is a sequence of standard mollifications of ω . In this passage to the limit we use the compact imbedding of $W^{2,2}(\Omega')$ into $C(\Omega')$ for a bounded domain Ω' in Ω containing the support of the test function $\varphi \in C_0^{\infty}(\Omega)$.

We shall look for a solution of Problem (1)–(4) in the form $\mathbf{v} = \mathbf{u} + \mathbf{a}$, $\rho = \omega(\psi)$, where $\omega \in C_b(\mathbb{R})$, ψ is a streamline function of \mathbf{v} , i.e. $\nabla^{\perp} \psi \stackrel{\text{def}}{=} (-\psi_y, \psi_x) = \mathbf{v}$, and \mathbf{a} is a vector field that is constructed below. We will need the following remark.

Remark 4. Notice that $\psi|_{\Gamma}$ must be constant on each component of Γ , because $\mathbf{v}|_{\Gamma} \equiv 0$. In particular, $\psi(x, d_i(x))$ is independent of x and $i = 1, 2$, as well as $\psi(x, -d_i(x))$. We may fix arbitrarily the constant value $\psi(x, -d_i(x))$, since \mathbf{v} does not change by modifying ψ by a constant. We set $\psi(x, -d_i(x)) \equiv 0$. Then from condition (3) we must have $\psi(x, d_i(x)) = \psi(x, -d_i(x)) - \alpha = -\alpha$.

Before stating our main result, we set the following additional notations, where $0 \leq x_1 < x_2$, $\eta \geq 1$ and $t > 0$:

$$\begin{aligned}
 d &= \max_{i=1,2} \{ \sup_{x < 0} d_1(x), \sup_{x > 0} d_2(x) \} \\
 \Omega_{1,x_1,x_2} &= \{ (x, y) \in \Omega_1 : -x_2 < x < -x_1 \} \\
 \Omega_{2,x_1,x_2} &= \{ (x, y) \in \Omega_2 : x_1 < x < x_2 \} \\
 \Omega_i^\eta &= \Omega_{i,\eta-1,\eta}, \quad i = 1, 2 \\
 \Omega_t &= \Omega_0 \cup \Omega_{1,0,t} \cup \Omega_{2,0,t} \\
 \Omega_{i,t,\infty} &= \Omega_t^c \cap \Omega_i, \quad i = 1, 2.
 \end{aligned} \tag{7}$$

Next we state our main result.

Theorem 1. *For any α, β in \mathbb{R} , Problem (1)–(4) admits a weak solution.*

The proof of Theorem 1 employs the construction of a smooth vector field $\mathbf{a} = (a_1, a_2) = \mathbf{a}(\delta, \Omega)$ that depends only on Ω and a positive parameter δ sufficiently small but arbitrary. This field has the following properties; see [5, Section 3]:

- a₁) $\mathbf{a} \in H_{1,loc}(\overline{\Omega})$;
- a₂) $\int_{\Sigma} a_1(x, y) dy = \alpha, \quad \forall x \in \mathbb{R}$;
- a₃) There exists a constant $\tilde{c}_{\mathbf{a}}$ independent of $\eta \geq 1$ such that

$$\int_{\Omega_i^\eta} |\nabla \mathbf{a}|^2 \leq \tilde{c}_{\mathbf{a}}, \quad \forall \eta \geq 1, \quad i = 1, 2;$$

and

- a₄)
$$\int_{\Omega_t} |\mathbf{a}|^2 |\Phi|^2 \leq \delta^2 \int_{\Omega_t} |\nabla \Phi|^2, \quad \forall \Phi \in \mathcal{V}, \quad \forall t > 0.$$

From property a₃) it follows that $\|\nabla \mathbf{a}\|_{L^2(\Omega_{i,x_1,x_2})}^2 \leq \tilde{c}_{\mathbf{a}}(x_2 - x_1 + 1)$, for all $x_1 < x_2 \in [0, \infty)$, $i = 1, 2$, thus

$$\|\nabla \mathbf{a}\|_{L^2(\Omega_t)}^2 \leq c_{\mathbf{a}}(t + 1) \tag{8}$$

for all $t > 0$, where $c_{\mathbf{a}} = 2\tilde{c}_{\mathbf{a}} + \|\nabla \mathbf{a}\|_{L^2(\Omega_0)}^2$.

First we look for a weak solution of (1)–(3). We reformulate this problem in the following way: Given $\omega \in C_b(\mathbb{R})$ and a vector field \mathbf{a} satisfying a₁)–a₄) (δ will be chosen such that $\delta\|\omega\|_{C_b(\mathbb{R})} < \mu$; see (15) below), find $\mathbf{u} = \nabla^\perp \psi - \mathbf{a} \in H_{1,loc}(\overline{\Omega})$, $\psi \in W_{loc}^{2,2}(\overline{\Omega})$, such that

$$\int_{\Sigma} u_1(x, y) dy = 0 \tag{9}$$

and

$$\mu \int_{\Omega} \nabla(\mathbf{u} + \mathbf{a}) \cdot \nabla \Phi dx = \int_{\Omega} \omega(\psi) ((\mathbf{u} + \mathbf{a}) \cdot \nabla \Phi) \cdot (\mathbf{u} + \mathbf{a}) dx, \quad \forall \Phi \in \mathcal{V}. \tag{10}$$

In fact, we are going to prove Theorem 2 below. Theorem 1 will follow easily from Theorem 2, but with a right choice of ω , as we shall see. This approach has not appeared in the literature yet, as far as we know.

Theorem 2. *Given any ω in $C_b(\mathbb{R})$, equation (9)–(10) has a solution $\psi \in W_{loc}^{2,2}(\overline{\Omega})$ ($\mathbf{u} = \nabla^\perp \psi - \mathbf{a}$).*

Proof. First we assume that ω belongs to $C_b^\infty(\mathbb{R})$ and make the proof in two steps. The first step will be to solve the problem in the bounded domain $\Omega_T, T > 0$, with homogeneous Dirichlet boundary condition in the whole boundary $\partial\Omega_T$. This will yield a sequence of functions (ρ^T, u^T) defined in Ω_T , where $\rho^T = \omega(\psi^T)$ with $\nabla^\perp \psi^T = \mathbf{u}^T + \mathbf{a}|_{\Omega_T}$ and \mathbf{u}^T will have null flux on the sections $\{(x, y) : y \in \Sigma(x)\}$ for all x such that $|x| < T$. The second step will consist in estimating the sequence $\{\rho^T, u^T\}$ in Ω_t with $t > 0$ fixed and $T > t + 1$. This estimate will be accomplished from the fact that $\{\rho^T\}$ is uniformly bounded in $L^\infty(\Omega_t)$ (a simple consequence of $\omega \in L^\infty$) and, most importantly, by using a “reverse type Gronwall lemma”, due to Ladyzhenskaya and Solonnikov [5, Lemma 2.3]; we quote it below. After this second step we will end the proof by showing how to pass to the case $\omega \in C_b(\mathbb{R})$ from the case $\omega \in C_b^\infty(\mathbb{R})$.

Ladyzhenskaya–Solonnikov’s lemma [5, Lemma 2.3]. *Let $z, \varphi : \mathbb{R} \rightarrow \mathbb{R}$ be smooth non-negative and non-decreasing functions satisfying the inequalities $z(t) \leq \Psi(z'(t)) + (1 - \delta_1)\varphi(t)$ and $\varphi(t) \geq \frac{1}{\delta_1}\Psi(\varphi'(t))$, for some $\delta_1 \in (0, 1)$ and for all t on a interval $[0, T], T > 0$, where $\Psi : \mathbb{R} \rightarrow \mathbb{R}$ is a smooth increasing function such that $\Psi(0) = 0$ and $\lim_{\tau \rightarrow \infty} \Psi(\tau) = \infty$. Suppose that $z(T) \leq \varphi(T)$. Then $z(t) \leq \varphi(t)$ for all $t \in [0, T]$.*

Generalized solution in the bounded domain Ω_T : We deal in this subsection with the equation

$$\mu \Delta(\mathbf{u}^T + \mathbf{a}) = \omega(\psi^T)(\mathbf{u}^T + \mathbf{a}) \cdot \nabla(\mathbf{u}^T + \mathbf{a}) + \nabla p^T, \quad \mathbf{u}^T \in H_1(\Omega_T) \tag{11}$$

where $\nabla^\perp \psi^T = \mathbf{u}^T + \mathbf{a}|_{\Omega_T}$ and p^T is the pressure function associated with \mathbf{u}^T . Recall that according to our notations, $H_1(\Omega_T)$ denotes the space of functions in $W_0^{1,2}(\Omega_T)$ that are divergence free in Ω_T . Besides, since $\mathbf{u}^T \in W_0^{1,2}(\Omega_T)$ implies $\mathbf{u}^T|_{\partial\Omega_T} = 0$, we have in particular that $u_1^T = 0$ on the cross sections $\Sigma((-1)^i T) = \{((-1)^i T, y) : -d_i(T) < y < d_i(T)\}, i = 1, 2$, then from $\nabla \cdot \mathbf{u}^T = 0$ and the divergence theorem, we have $\int_\Sigma u_1^T(x, y) dy = 0$ for all $x \in (-T, T)$.

Let $\{\Phi_k\}_{k \geq 1}$ be an orthonormal basis of $H_1(\Omega_T)$ with respect to the inner product $\int_{\Omega_T} \nabla \mathbf{u} \cdot \nabla \mathbf{v}$. We then solve the following “approximate” problem:

$$\begin{cases} \mathbf{u}_m = \sum_{k=1}^m \xi_{km} \Phi_k, & \mathbf{u}_m + \mathbf{a} = \nabla^\perp \psi_m; & \xi_{1m}, \dots, \xi_{mm} \in \mathbb{R} \\ \mu \int_{\Omega_T} \nabla(\mathbf{u}_m + \mathbf{a}) \cdot \nabla \Phi_k = \int_{\Omega_T} \omega(\psi_m)((\mathbf{u}_m + \mathbf{a}) \cdot \nabla \Phi_k) \cdot (\mathbf{u}_m + \mathbf{a}), & \\ k = 1, 2, \dots, m. \end{cases} \tag{12}$$

From now on we set

$$l \stackrel{\text{def}}{=} \|\omega\|_{C_b(\mathbb{R})}.$$

For each $m \in \mathbb{R}^m$, (12) is a system of nonlinear algebraic equations for the unknown $\xi = (\xi_{1m}, \dots, \xi_{1m}) \in \mathbb{R}^m$. It has a solution if δ is appropriately chosen; see (15) below. This can be inferred from Brouwer’s fixed point theorem. Indeed, if we set

$$F_k(\xi) = \mu \int_{\Omega_T} \nabla(\mathbf{u}_m + \mathbf{a}) \cdot \nabla \Phi_k - \int_{\Omega_T} \omega(\psi_m)((\mathbf{u}_m + \mathbf{a}) \cdot \nabla \Phi_k) \cdot (\mathbf{u}_m + \mathbf{a})$$

then (12) becomes the problem of finding a singular point of the vector field $\mathbf{F} \stackrel{\text{def}}{=} (F_1, \dots, F_m)$ in \mathbb{R}^m , i.e. find $\xi \in \mathbb{R}^m$ such that $\mathbf{F}(\xi) = 0$. Besides, we have the estimate

$$\begin{aligned} \mathbf{F}(\xi) \cdot \xi &= \mu |\xi|_{\mathbb{R}^m}^2 + \mu \int_{\Omega_T} \nabla \mathbf{a} \cdot \nabla \mathbf{u}_m - \int_{\Omega_T} \omega(\psi_m)((\mathbf{u}_m + \mathbf{a}) \cdot \nabla) \mathbf{u}_m \cdot \mathbf{a} \\ &\geq \mu |\xi|_{\mathbb{R}^m}^2 - \mu \|\nabla \mathbf{a}\|_{L^2(\Omega_T)} |\xi|_{\mathbb{R}^m} \\ &\quad - l (\|\mathbf{u}_m \mathbf{a}\|_{L^2(\Omega_T)} |\xi|_{\mathbb{R}^m} + \|\mathbf{a}\|_{L^4(\Omega_T)}^2 |\xi|_{\mathbb{R}^m}) \\ &\geq (\mu - \delta l) |\xi|_{\mathbb{R}^m}^2 - \left(\mu \|\nabla \mathbf{a}\|_{L^2(\Omega_T)} + l \|\mathbf{a}\|_{L^4(\Omega_T)}^2 \right) |\xi|_{\mathbb{R}^m} \end{aligned} \tag{13}$$

where we used the identity

$$\int_{\Omega_T} \omega(\psi_m) ((\mathbf{u}_m + \mathbf{a}) \cdot \nabla \mathbf{u}_m) \cdot \mathbf{u}_m = 0 \tag{14}$$

(remind that $\nabla \cdot (\omega(\psi_m)(\mathbf{u}_m + \mathbf{a})) = 0$) and for the last inequality we used property a_4) of the vector field \mathbf{a} . Thus, by choosing $\delta > 0$ such that

$$\delta l < \mu, \tag{15}$$

we obtain $\mathbf{F}(\xi) \cdot \xi > 0$ for all ξ sufficiently large. Therefore, as a corollary of Brouwer’s fixed point theorem, we infer that \mathbf{F} has a singular point. See e.g. the proof of [7, Lemma II.1.4]. The corresponding solution $\mathbf{u}_m = \sum_{k=1}^m \xi_{km} \Phi_k$ of (12) satisfies the estimate

$$\|\nabla \mathbf{u}_m\|_{L^2(\Omega_T)} \leq \frac{\mu \|\nabla \mathbf{a}\|_{L^2(\Omega_T)} + l \|\mathbf{a}\|_{L^4(\Omega_T)}^2}{\mu - \delta l}, \tag{16}$$

for all $m \geq 1$, what can be seen by taking $\mathbf{F}(\xi) = 0$ in (13). We then find a subsequence $(u_{m'})$ that converges weakly in $H_1(\Omega_T)$ and strongly in $L^2(\Omega_T)$ to some function $\mathbf{u}^T \in H_1(\Omega_T)$. As a consequence, $(\psi_{m'})$ converges weakly to some function ψ^T in $W^{2,2}(\Omega_T)$, such that $\nabla^\perp \psi^T = \mathbf{u}^T + \mathbf{a}|_{\Omega_T}$. Noting that $W^{2,2}(\Omega_T)$ is compactly embedded in $C(\overline{\Omega_T})$, we deduce that $\omega(\psi_{m'})$ converges to $\omega(\psi^T)$ in $C(\overline{\Omega_T})$ and then, by a routine argument, that $\mathbf{u}^T = \nabla^\perp \psi^T - \mathbf{a}|_{\Omega_T}$ verifies (10) for all Φ in \mathcal{V} , which means that $\mathbf{u} = \mathbf{u}^T$ is a weak solution of (11) with $\psi = \psi^T$. Moreover,

$$\|\nabla \mathbf{u}^T\|_{L^2(\Omega_T)}^2 \leq (\mu - \delta l)^{-2} \mathcal{F}(T) \tag{17}$$

where

$$\mathcal{F}(T) \stackrel{\text{def}}{=} (\mu \|\nabla \mathbf{a}\|_{L^2(\Omega_T)} + l \|\mathbf{a}\|_{L^4(\Omega_T)}^2)^2.$$

From the estimate

$$\|\mathbf{a}\|_{L^4(\Omega_T)}^2 \leq c_0 \|\nabla \mathbf{a}\|_{L^2(\Omega_T)}^2, \tag{18}$$

where $c_0 = c_0(\Omega_0, d)$ (see [2, Lemma XI.2.1]) and from (8), we have

$$\mathcal{F}(T) \leq c_a^2(\mu + lc_0)^2(T + 1)^2, \tag{19}$$

where we assume $c_a \geq 1$, without loss of generality.

Convergence of $(\rho^T, \mathbf{u}^T) = (\omega(\psi^T), \mathbf{u}^T)$ to a solution (ρ, \mathbf{u}) of (10): Let

$$y(t) \stackrel{\text{def}}{=} \int_{\Omega_t} |\nabla \mathbf{u}^T|^2.$$

From properties $a_1)$ – $a_4)$ of the field \mathbf{a} we shall obtain the estimate

$$y(t) \leq \hat{c}(t + 1)^2 + \tilde{c}, \quad \forall T \geq t + 1, \tag{20}$$

where \hat{c} and \tilde{c} are constants with respect to \mathbf{u}^T ; see (37) and (38) below. To shorten notation, let us write for a while, $\mathbf{u} = \mathbf{u}^T$, $\mathbf{v} = \mathbf{u}^T + \mathbf{a}|_{\Omega_T} = \nabla \psi^T$, $\rho = \rho^T = \omega(\psi^T)$ and $p = p^T$. Since ω is smooth, from classical results on regularity of Navier–Stokes equations, we have that $\mathbf{u} = \mathbf{u}^T$ is a strong solution of (11), then we can multiply equation (11) by \mathbf{u} and integrate by parts on Ω_t , with $T > t + 1$, to get

$$\begin{aligned} \mu y(t) = & \int_{\Omega_t} \rho(\mathbf{v} \cdot \nabla \mathbf{u}) \cdot \mathbf{a} - \mu \nabla \mathbf{u} \cdot \nabla \mathbf{a} \\ & + \int_{\Gamma_t} \mu \frac{\partial \mathbf{v}}{\partial \mathbf{n}} \cdot \mathbf{u} - \frac{1}{2} \rho(\mathbf{v} \cdot \mathbf{n})|\mathbf{u}|^2 - \rho(\mathbf{v} \cdot \mathbf{n})(\mathbf{a} \cdot \mathbf{u}) - p(\mathbf{u} \cdot \mathbf{n}), \end{aligned} \tag{21}$$

where $\Gamma_t \stackrel{\text{def}}{=} \Sigma_t \cup \Sigma_{-t}$, $\Sigma_{\pm t} \stackrel{\text{def}}{=} \Sigma(\pm t)$. Notice that because $\mathbf{u} = \mathbf{a} = 0$ on $\partial\Omega$, the boundary integral above occurs only on the set Γ_t . First we estimate the interior integral in (21):

$$\begin{aligned} & \int_{\Omega_t} \rho(\mathbf{v} \cdot \nabla \mathbf{u}) \cdot \mathbf{a} - \mu \nabla \mathbf{u} \cdot \nabla \mathbf{a} \\ = & \int_{\Omega_t} \rho(\mathbf{u} \cdot \nabla \mathbf{u}) \cdot \mathbf{a} + \rho(\mathbf{a} \cdot \nabla \mathbf{u}) \cdot \mathbf{a} - \mu \nabla \mathbf{u} \cdot \nabla \mathbf{a} \\ \leq & l\delta y(t) + (\mathcal{F}(t)y(t))^{1/2} \leq (\delta l + \gamma)y(t) + \frac{1}{4\gamma}\mathcal{F}(t) \end{aligned} \tag{22}$$

where, in the first inequality we used property $a_4)$, and in the last inequality, γ is a positive constant that will be fixed; see (34) below. From (21) and (22), we have

$$(\mu - \delta l - \gamma) y(t) \leq \frac{1}{4\gamma}\mathcal{F}(t) + \int_{\Gamma_t} \dots, \tag{23}$$

where $\int_{\Gamma_t} \dots$ stands for the boundary integral in (21). To estimate $\int_{\Gamma_t} \dots$ we integrate (23) with respect to t , for $\eta - 1 < t < \eta$, where $1 \leq \eta \leq T$, and set

$$z(\eta) \stackrel{\text{def}}{=} \int_{\eta-1}^{\eta} y(t) dt.$$

From (23) and (19) we obtain

$$z(\eta) \leq c_1(\eta + 1)^2 + (\mu - \delta l - \gamma)^{-2} \int_{\eta-1}^{\eta} \int_{\Gamma_t} \dots, \tag{24}$$

for $\gamma < \mu - \delta l$, where

$$c_1 = \frac{c_{\mathbf{a}}^2(\mu + lc_0)^2}{4\gamma(\mu - \delta l - \gamma)}. \tag{25}$$

Before proceeding, two claims are in order:

(i) $y(\eta - 1) \leq z(\eta) \leq y(\eta)$;

(ii) $z'(\eta) = y(\eta) - y(\eta - 1) = \int_{\Omega_1^\eta \cup \Omega_2^\eta} |\nabla \mathbf{u}|^2 = \int_{\eta-1}^\eta \int_{\Gamma_t} |\nabla \mathbf{u}|^2$.

These two claims hold for all $\eta \in [1, T]$. Claim (i) implies that to estimate y is equivalent to estimate z . The estimate for z will be attained first by estimating each term in the integral $\int_{\eta-1}^\eta \int_{\Gamma_t} \dots$ by $|\nabla \mathbf{u}|^2$ to some power times some constant. Once we have these estimates, by claim (ii) and (24) we will have

$$z(\eta) \leq c_1(\eta + 1)^2 + \Psi(z'(\eta)), \tag{26}$$

for some function Ψ ; see (32) below. Then using Ladyzhenskaya–Solonnikov’s lemma and (17) we will obtain

$$z(\eta) \leq c_1(\eta + 1)^2 + \tilde{c}_1, \tag{27}$$

for some constant \tilde{c}_1 ; see (36) below. Thus, in view of claim (i), we will have the desired estimate (20).

The first term in the integral $\int_{\eta-1}^\eta \int_{\Gamma_t} \dots$ is easily estimated by using Hölder and Poincaré inequalities, and property a_3):

$$\begin{aligned} \left| \int_{\eta-1}^\eta \int_{\Gamma_t} \mu \frac{\partial \mathbf{v}}{\partial \mathbf{n}} \cdot \mathbf{u} \right| &= \left| \int_{\eta-1}^\eta \int_{\Gamma_t} \mu \frac{\partial \mathbf{u}}{\partial \mathbf{n}} \cdot \mathbf{u} + \int_{\eta-1}^\eta \int_{\Gamma_t} \mu \frac{\partial \mathbf{a}}{\partial \mathbf{n}} \cdot \mathbf{u} \right| \\ &\leq \mu d \int_{\eta-1}^\eta \int_{\Gamma_t} |\nabla \mathbf{u}|^2 + \mu \tilde{c}_{\mathbf{a}}^{1/2} \left(\int_{\eta-1}^\eta \int_{\Gamma_t} |\nabla \mathbf{u}|^2 \right)^{1/2} \\ &\leq \mu dz'(\eta) + \mu \tilde{c}_{\mathbf{a}}^{1/2} z'(\eta)^{1/2}. \end{aligned} \tag{28}$$

Analogously, for the second and third terms, using the inequality

$$\|\mathbf{a}\|_{L^4(\Omega_\eta^\eta)}^2 \leq \kappa \|\nabla \mathbf{a}\|_{L^2(\Omega_\eta^\eta)}^2, \quad i = 1, 2, \quad \eta \geq 1, \tag{29}$$

where $\kappa = \kappa(d)$ ([2, Lemma XI.2.1] or [5, p.759]), we have

$$\begin{aligned} &\left| \int_{\eta-1}^\eta \int_{\Gamma_t} \frac{1}{2} \rho(\mathbf{v} \cdot \mathbf{n}) |\mathbf{u}|^2 - \rho(\mathbf{v} \cdot \mathbf{n})(\mathbf{a} \cdot \mathbf{u}) \right| \\ &= \left| \int_{\eta-1}^\eta \int_{\Gamma_t} \frac{1}{2} \rho(\mathbf{u} \cdot \mathbf{n}) |\mathbf{u}|^2 + \frac{1}{2} \rho(\mathbf{a} \cdot \mathbf{n}) |\mathbf{u}|^2 - \rho(\mathbf{u} \cdot \mathbf{n})(\mathbf{a} \cdot \mathbf{u}) - \rho(\mathbf{a} \cdot \mathbf{n})(\mathbf{a} \cdot \mathbf{u}) \right| \\ &\leq \frac{1}{2} d \kappa z'(\eta)^{3/2} + \frac{1}{2} d \tilde{c}_{\mathbf{a}}^{1/2} \kappa z'(\eta) + l d \tilde{c}_{\mathbf{a}}^{1/2} \kappa z'(\eta) + l \kappa \tilde{c}_{\mathbf{a}} dz'(\eta)^{1/2}. \end{aligned} \tag{30}$$

The last term is more tricky and requires to solve the equation $\nabla \cdot \mathbf{w} = \mathbf{u} \cdot \mathbf{n}$ for $\mathbf{w} \in W_0^{1,2}(\Omega_1^\eta \cup \Omega_2^\eta)$ with the estimate

$$\|\nabla \mathbf{w}\|_{L^2(\Omega_\eta^\eta)} \leq M_1 \|\mathbf{u}\|_{L^2(\Omega_\eta^\eta)}, \quad i = 1, 2,$$

where M_1 is a universal constant (in particular, independent of η); see [5, (2.7)] or [2, Lemma III.3.1]. Substituting this equation in the last term in the integral $\int_{\eta-1}^{\eta} \int_{\Gamma_t} \dots$, integrating by parts, and using equation (11), we have

$$\begin{aligned}
 & - \int_{\eta-1}^{\eta} \int_{\Gamma_t} p(\mathbf{u} \cdot \mathbf{n}) = - \int_{\eta-1}^{\eta} \int_{\Gamma_t} p \nabla \cdot \mathbf{w} = \int_{\eta-1}^{\eta} \int_{\Gamma_t} \nabla p \cdot \mathbf{w} \\
 & = \int_{\eta-1}^{\eta} \int_{\Gamma_t} (\mu \Delta \mathbf{v} - \rho \mathbf{v} \cdot \nabla \mathbf{v}) \cdot \mathbf{w} \\
 & = \int_{\eta-1}^{\eta} \int_{\Gamma_t} -\mu \nabla \mathbf{v} \cdot \nabla \mathbf{w} + \rho (\mathbf{v} \cdot \nabla \mathbf{w}) \cdot \mathbf{v} \\
 & \leq \left(\mu \left(\int_{\eta-1}^{\eta} \int_{\Gamma_t} |\nabla \mathbf{v}|^2 \right)^{1/2} + l \left(\int_{\eta-1}^{\eta} \int_{\Gamma_t} |\mathbf{v}|^4 \right)^{1/2} \right) \left(\int_{\eta-1}^{\eta} \int_{\Gamma_t} |\nabla \mathbf{w}|^2 \right)^{1/2} \tag{31} \\
 & \leq \left(\mu \left(\int_{\eta-1}^{\eta} \int_{\Gamma_t} |\nabla \mathbf{u}|^2 \right)^{1/2} + \mu \tilde{c}_{\mathbf{a}}^{1/2} + l\kappa \left(\int_{\eta-1}^{\eta} \int_{\Gamma_t} |\mathbf{u}|^2 \right) + l\kappa \tilde{c}_{\mathbf{a}} \right) \\
 & \qquad M_1 \left(\int_{\eta-1}^{\eta} \int_{\Gamma_t} |\mathbf{u}|^2 \right)^{1/2} \\
 & \leq M_1 \left((\mu \tilde{c}_{\mathbf{a}}^{1/2} + l\kappa \tilde{c}_{\mathbf{a}}) z'(\eta)^{1/2} + \mu z'(\eta) + l\kappa z'(\eta)^{3/2} \right).
 \end{aligned}$$

From (24), (28)–(31), we obtain

$$z(\eta) \leq \frac{1}{2} \varphi(\eta) + \Psi(z'(\eta)),$$

where

$$\varphi(\eta) \stackrel{\text{def}}{=} 2c_1(\eta + 1)^2$$

and

$$\Psi(\tau) \stackrel{\text{def}}{=} c_2 c \left(\tau^{1/2} + \tau + \tau^{3/2} \right), \tag{32}$$

with

$$c_2 = \frac{1 + l}{\mu - \delta l - \gamma}$$

and $c = c(\delta, \Omega, \mu)$. Now we are almost ready to use Ladyzhenskaya–Solonnikov’s lemma. To this end, first we would like to have

$$z(T) \leq \varphi(T). \tag{33}$$

Since from (17) and (19),

$$z(T) \leq y(T) \leq \frac{c_{\mathbf{a}}^2 (\mu + lc_0)^2}{(\mu - \delta l)^2} (T + 1)^2,$$

and $\varphi(T) = 2c_1(T + 1)^2$, where c_1 is given in (25), to have (33) it is enough to set

$$\gamma = \frac{\mu - \delta l}{2}. \tag{34}$$

Indeed, with this choice we have precisely

$$2c_1 = \frac{c_{\mathbf{a}}^2 (\mu + lc_0)^2}{(\mu - \delta l)^2}$$

and so

$$z(T) = 2c_1(T + 1)^2 = \varphi(T).$$

Secondly, we would like to have the estimate $\frac{1}{2}\Psi(\varphi'(\eta)) \leq \varphi(\eta)$ for all $\eta \geq 1$, i.e.

$$c \frac{1+l}{\mu-\delta l} \left((4c_1(\eta+1))^{1/2} + 4c_1(\eta+1) + (4c_1(\eta+1))^{3/2} \right) \leq 2c_1(\eta+1)^2. \quad (35)$$

This inequality is perhaps false for values of η not large, so we modify $\varphi(\eta)$ by adding a positive constant \tilde{c}_1 to it; notice that this modification does not affect the inequality (33). Since

$$\Psi(\varphi'(\eta)) \leq 3cc_2(4c_1(\eta+1))^{3/2},$$

to have the desired inequality

$$\frac{1}{2}\Psi(\varphi'(\eta)) \leq \varphi(\eta) + \tilde{c}_1$$

satisfied, for all $\eta \geq 1$, it is enough to choose \tilde{c}_1 such that

$$\frac{3}{2}cc_2(4c_1(\eta+1))^{3/2} \leq \varphi(\eta) + \tilde{c}_1, \quad \forall \eta \geq 1;$$

but

$$\frac{3}{2}cc_2(4c_1(\eta+1))^{3/2} \leq \frac{1}{2}\varphi(\eta) = 2c_1(\eta+1)^2$$

iff $\eta + 1 \geq 36c^2c_2^2c_1 \equiv \eta_0 + 1$, then we choose

$$\tilde{c}_1 = \frac{3}{2}cc_2(4c_1(\eta+1))^{3/2}|_{\eta=\eta_0}$$

i.e.

$$\tilde{c}_1 = cc_2^4c_1^3$$

where c is a new constant $c = c(\delta, \Omega, \mu)$; more precisely,

$$\tilde{c}_1 = c \frac{(1+l)^4(\mu+lc_0)^6}{(\mu-\delta l)^7}. \quad (36)$$

With this value of \tilde{c}_1 fixed, we have

$$\frac{1}{2}\Psi(\varphi'(\eta)) \leq 3cc_2(4c_1(\eta+1))^{3/2} \leq \varphi(\eta) + \tilde{c}_1, \quad \forall \eta \geq 1.$$

Therefore, by Ladyzhenskaya-Solonnikov's lemma we have (27), for all $\eta \in [1, T]$, and so, using that $y(\eta-1) \leq z(\eta)$ (claim (i) above) we obtain estimate (20) with

$$\hat{c} = 3c_1 = \frac{3c_a^2(\mu+lc_0)^2}{(\mu-\delta l)^2} \quad (37)$$

and

$$\tilde{c} = c_1 + \tilde{c}_1 = \frac{c_a^2(\mu+lc_0)^2}{(\mu-\delta l)^2} + c \frac{(1+l)^4(\mu+lc_0)^6}{(\mu-\delta l)^7}. \quad (38)$$

We recall that the constants c_a , c_0 and c depend only on δ , Ω and μ .

With estimate (20), we take a sequence $t_1 < t_2 < \dots \rightarrow \infty$, and by passing to subsequences of subsequences of (\mathbf{u}^T) , we obtain a solution $\mathbf{u} \in H_{1,loc}(\overline{\Omega})$ of (10), which satisfies

$$\int_{\Omega_{t_i}} |\nabla \mathbf{u}|^2 \leq \hat{c}(t_i + 1)^2 + \tilde{c}. \tag{39}$$

Passage to the case $\omega \in C_b(\mathbb{R})$: We consider the convolution $\omega^\epsilon \stackrel{\text{def}}{=} \omega * j_\epsilon$, where (j_ϵ) is a family of mollifiers. For a $\delta > 0$ satisfying (15), let \mathbf{a} be a smooth vector field having the properties a₁)-a₄) above. Since $l_\epsilon \stackrel{\text{def}}{=} \|\omega^\epsilon\|_{C_b(\mathbb{R})} \leq \|\omega\|_{C_b(\mathbb{R})} = l$, we have (15) satisfied with l_ϵ in place of l for all ϵ . Then we take the corresponding solution $\mathbf{v}^\epsilon = \mathbf{u}^\epsilon + \mathbf{a} = \nabla^\perp \psi^\epsilon$ of (10) satisfying (39), with ω^ϵ in place of ω . From (37)-(39) we get the uniform estimate with respect to ϵ :

$$\int_{\Omega_{t_i}} |\nabla \mathbf{u}^\epsilon|^2 \leq \hat{c}(t_i + 1)^2 + \tilde{c},$$

$i = 1, 2, \dots$. Therefore, for each $i = 1, 2, \dots$ we can extract a subsequence $\{\epsilon_{i+1}^k\}_{k=1}^\infty \subset \{\epsilon_i^k\}_{k=1}^\infty$ such that for some function $\mathbf{u} \in H_{1,loc}(\overline{\Omega})$, we have that $(\mathbf{u}^{\epsilon_i^k})$ converges to $\mathbf{u}|_{\Omega_{t_i}}$ in $H_1(\Omega_{t_i})$ as k goes to infinity. It is easy to check that \mathbf{u} is a solution of (10). Indeed, given a function $\Phi \in \mathcal{V}$, taking $t_i > 0$ such that $\text{spt. } \Phi \subset \Omega_{t_i}$, we have

$$\begin{aligned} & \int_{\Omega} \omega^{\epsilon_i^k}(\psi^{\epsilon_i^k})(\mathbf{v}^{\epsilon_i^k} \cdot \nabla \Phi) \cdot \mathbf{v}^{\epsilon_i^k} \\ &= \int_{\Omega_{t_i}} \omega^{\epsilon_i^k}(\psi^{\epsilon_i^k})(\mathbf{v}^{\epsilon_i^k} \cdot \nabla \Phi) \cdot \mathbf{v}^{\epsilon_i^k} \xrightarrow{k \rightarrow 0} \int_{\Omega_{t_i}} \omega(\psi)(\mathbf{v} \cdot \nabla \Phi) \cdot \mathbf{v} \\ &= \int_{\Omega} \omega(\psi)(\mathbf{v} \cdot \nabla \Phi) \cdot \mathbf{v}, \end{aligned}$$

since $\psi^{\epsilon_i^k} \xrightarrow{k \rightarrow 0} \psi$ in $C(\Omega_{t_i})$, $\omega^{\epsilon_i^k} \xrightarrow{k \rightarrow 0} \omega$ in $C(K)$ for each compact subset K of \mathbb{R} , and $\mathbf{v}^{\epsilon_i^k} \xrightarrow{k \rightarrow 0} \mathbf{v}$ in $L^4(\Omega_{t_i})$. □

Proof of Theorem 1. Let $\omega \in C_b(\mathbb{R})$ such that

$$\int_{-\alpha}^0 \omega(s) ds = \beta. \tag{40}$$

From Theorem 2, there exists a $\mathbf{v} = (v_1, v_2) \in H_{1,loc}(\overline{\Omega})$, $\mathbf{v} = \mathbf{u} + \mathbf{a}$, such that equation (10) is satisfied and $\int_{\Sigma} v_1(x, y) dy = \alpha$, i.e. equation (3) is also satisfied.

From Remark 3 and (10)/Theorem 2, equations (5) and (6) are satisfied with $\mathbf{v} = \mathbf{u} + \mathbf{a}$ and $\rho = \omega(\psi)$. Conditions $\nabla \cdot \mathbf{v} = 0$ and $\mathbf{v}|_{\partial\Omega} = 0$ are included in the definition of $H_{1,loc}(\overline{\Omega})$ (see Notations).

It remains to check equation (4). Let $W(s) \stackrel{\text{def}}{=} \int_0^s \omega(r) dr$. Using Remark 4, we have

$$\begin{aligned}
 \int_{\Sigma} \rho v_1(x, y) dy &= - \int_{-d_i(x)}^{d_i(x)} \omega(\psi) \psi_y(x, y) dy \\
 &= - \int_{-d_i(x)}^{d_i(x)} \partial_y W(\psi(x, y)) dy \\
 &= W(\psi(x, -d_i(x))) - W(\psi(x, d_i(x))) \\
 &= \int_{\psi(x, d_i(x))}^{\psi(x, -d_i(x))} \omega(s) ds = \int_{-\alpha}^0 \omega(s) ds = \beta. \quad \square
 \end{aligned} \tag{41}$$

References

- [1] C.J. Amick, *Steady solutions of the Navier–Stokes equations in unbounded channels and pipes*, Ann. Scuola Norm. Sup. Pisa Cl.Sci. (4), **4**(3) (1977) 473–513.
- [2] G.P. Galdi, *An Introduction to the Mathematical Theory of the Navier–Stokes Equations*, v. I & II, Springer-Verlag (1994).
- [3] F. Ammar-Khodja and M.M. Santos, *2d density-dependent Leray’s problem for inhomogeneous fluids*, Mat. Contemp., to appear.
- [4] O.A. Ladyzhenskaya, *Stationary motion of a viscous incompressible fluid in a pipe*, Dokl. Akad. Nauk. SSSR, **124** (1959) 551–553.
- [5] O.A. Ladyzhenskaya and V.A. Solonnikov, *Determination of solutions of boundary value problems for steady-state Stokes and Navier–Stokes equations in domains having an unbounded Dirichlet integral*, Zap. Nauchn. Sem. Leningrad Otdel. Mat. Inst. Steklov (LOMI), **96**, 117–160; English Transl.: J. Soviet Math. **21** (1983) 728–761.
- [6] J. Pedlosky, *Geophysical Fluid Dynamics*, Springer-Verlag (1984).
- [7] R. Temam, *Navier–Stokes equations. Theory and Numerical Analysis*. Studies in Mathematics and its Applications, Vol. 2. North-Holland Publishing Co., Amsterdam–New York–Oxford (1979)

Farid Ammar Khodja

Département de Mathématiques & UMR 6623, Université de Franche-Comté

16, route de Gray, 25030 Besancon Cedex

France

e-mail: ammar@math.univ-fcomte.fr

Marcelo M. Santos¹

Departamento de Matemática, IMECC–UNICAMP

Cx. Postal 6065, 13081-970 Campinas, SP,

Brazil

e-mail: msantos@ime.unicamp.br

¹Partially supported by Pronex/CNPq/Brazil/27697100500.

Generalization of a Well-known Inequality

YanYan Li and Louis Nirenberg

Dedicated to Djairo De Figueiredo on his seventieth birthday

Section 1.

The well-known inequality refers to a nonnegative C^2 function u defined on an interval $(-R, R)$. The inequality is in:

Proposition 1. *Assume*

$$|\ddot{u}| \leq M.$$

Then,

$$|\dot{u}(0)| \leq \sqrt{2u(0)M} \quad \text{if } M \geq \frac{2u(0)}{R^2} \quad (1)$$

$$|\dot{u}(0)| \leq \frac{u(0)}{R} + \frac{R}{2}M \quad \text{if } M < \frac{2u(0)}{R^2}. \quad (2)$$

This is sometimes called Glaeser's inequality, see [2]; there it is attributed to Malgrange. It was used by Nirenberg and Treves in [3], where it is said that the inequality was probably known to Cauchy.

Here is the simple

Proof. For x in $(-R, R)$,

$$u(x) = u(0) + x\dot{u}(0) + \int_0^x (x-y)\ddot{u}(y)dy.$$

So

$$|\dot{u}(0)| \leq \frac{u(0)}{|x|} + \frac{|x|}{2}M. \quad (3)$$

If $R \geq \sqrt{\frac{2u(0)}{M}}$, minimize the right hand side of (3) for $|x|$ on $(0, R)$. This yields (1). If $R < \sqrt{\frac{2u(0)}{M}}$, simply take $|x| = R$ — to get (2). \square

The function $u = (x + R)^2$ shows that the constant $\sqrt{2}$ in (1) cannot be improved. We present here several generalizations to higher dimensions. Our first

generalization is for C^2 , nonnegative function u defined on a ball $B_R = \{|x| \leq R\}$ in \mathbb{R}^n .

Proposition 2. *Assume*

$$\max |\Delta u| = M.$$

Then there is a constant C depending only on n such that

$$|\nabla u(x)| \leq C\sqrt{u(0)M} \quad \text{if } R \geq \sqrt{\frac{u(0)}{M}} \geq 2|x|, \tag{4}$$

$$|\nabla u(x)| \leq C\left(\frac{u(0)}{R} + RM\right) \quad \text{if } 2|x| \leq R < \sqrt{\frac{u(0)}{M}}. \tag{5}$$

Question 1. *What is the best constant C in (4) for $x = 0$?*

Proof of Proposition 2. For $0 < r < R$, let v be the function which is harmonic in $|x| \leq r$, with

$$v = u \quad \text{on } |x| = r.$$

Then $w = u - v$ satisfies

$$\begin{aligned} |\Delta w| = |\Delta u| &\leq M \quad \text{in } B_r, \\ w &= 0 \quad \text{on } \partial B_r. \end{aligned}$$

A standard inequality is

$$r|\nabla w(x)| + |w(x)| \leq CMr^2, \quad \forall |x| \leq \frac{r}{2}. \tag{6}$$

Here, and from now on in this proof, C represents different positive constants depending only on n . Now, by the gradient estimates and the Harnack inequality,

$$r|\nabla v(x)| \leq C \sup_{B_{\frac{3r}{4}}} v \leq Cv(0), \quad \forall |x| \leq \frac{r}{2}. \tag{7}$$

Combining (6) and (7) we find

$$r|\nabla u(x)| \leq C(Mr^2 + v(0)) \leq C(Mr^2 + u(0) + CMr^2), \quad \forall |x| \leq \frac{r}{2}.$$

Thus

$$|\nabla u(x)| \leq C\left(\frac{u(0)}{r} + Mr\right), \quad \forall |x| \leq \frac{r}{2}.$$

If $R \geq \sqrt{\frac{u(0)}{M}}$, we take $r = \sqrt{\frac{u(0)}{M}}$, and we obtain (4). If $R < \sqrt{\frac{u(0)}{M}}$, we take $r = R$, and we obtain (5). □

Section 2.

Here is another simple generalization for $u \geq 0$ in B_R .

Proposition 3. *Suppose*

$$\|\Delta u\|_{L^p(B_R)} = M \quad \text{for some } p > n.$$

Then

$$|\nabla u(x)| \leq C u(0)^{\frac{p-n}{2p-n}} M^{\frac{p}{2p-n}} \quad \text{if } R \geq \left(1 - \frac{n}{p}\right)^{\frac{p}{n-2p}} \left(\frac{u(0)}{M}\right)^{\frac{p}{2p-n}} \geq 2|x|, \quad (8)$$

$$|\nabla u(x)| \leq C \left(\frac{u(0)}{R} + MR^{1-\frac{n}{p}}\right) \quad \text{if } 2|x| \leq R < \left(1 - \frac{n}{p}\right)^{\frac{p}{n-2p}} \left(\frac{u(0)}{M}\right)^{\frac{p}{2p-n}}. \quad (9)$$

Here C is a constant depending only on n and p .

Proof. For $0 < r < R$, let v and w be defined in B_r as in the preceding proof. First we have

$$r|\nabla v(x)| \leq C \sup_{B_{\frac{3}{4}r}} v \leq Cv(0), \quad \forall |x| \leq \frac{r}{2}.$$

Next, by standard estimates, for $p > n$,

$$r|\nabla w(x)| + |w(x)| \leq CMr^{2-\frac{n}{p}}, \quad \forall |x| \leq \frac{r}{2}. \quad (10)$$

Here $C = C(n, p)$. Hence

$$r|\nabla u(x)| \leq CMr^{2-\frac{n}{p}} + Cv(0) \leq CMr^{2-\frac{n}{p}} + Cu(0), \quad \forall |x| \leq \frac{r}{2}$$

i.e.

$$|\nabla u(x)| \leq C \left(\frac{u(0)}{r} + Mr^{1-\frac{n}{p}}\right), \quad \forall |x| \leq \frac{r}{2}. \quad (11)$$

The minimum of the right hand side of (11), with respect to r , is achieved when

$$-\frac{u(0)}{r^2} + \left(1 - \frac{n}{p}\right)Mr^{-\frac{n}{p}} = 0$$

i.e. when

$$r = \left(1 - \frac{n}{p}\right)^{\frac{p}{n-2p}} \left(\frac{u(0)}{M}\right)^{\frac{p}{2p-n}}.$$

Arguing then as before, we obtain (8) and (9). □

Section 3.

What can we say if $u \geq 0$ and

$$M = \|\Delta u\|_{L^p(B_R)} \quad \text{for some } p \leq n? \quad (12)$$

If $p \in (\frac{n}{2}, n)$ we can obtain a Hölder continuity result with exponent

$$\alpha = 2 - \frac{n}{p} \quad (13)$$

in a form like (9). Namely we have

Proposition 4. *Suppose $u \geq 0$ in B_R and (12) holds with some $p \in (\frac{n}{2}, n)$. Then, for $x, y \in B_{R/2}$, $x \neq y$, and $\alpha = 2 - \frac{n}{p}$,*

$$\frac{|u(x) - u(y)|}{|x - y|^\alpha} \leq C\left(\frac{u(0)}{R^\alpha} + MR^{2-\frac{n}{p}-\alpha}\right) \tag{14}$$

where C depends on n and p .

Proof. Let v and w be defined as before, but in the entire ball B_R . By standard elliptic estimates and the Harnack inequality, since $\frac{n}{2} < p < n$, we have, for $x \neq y$ in $B_{R/2}$,

$$R^\alpha \frac{|v(x) - v(y)|}{|x - y|^\alpha} \leq C \sup_{B_{\frac{3R}{4}}} v \leq Cv(0).$$

Also

$$|w(0)| + R^\alpha \frac{|w(x) - w(y)|}{|x - y|^\alpha} \leq CMR^{2-\frac{n}{p}}. \tag{15}$$

Combining these, we find, as before,

$$R^\alpha \frac{|u(x) - u(y)|}{|x - y|^\alpha} \leq CMR^{2-\frac{n}{p}} + Cu(0),$$

namely, (14). □

Remark 1. *More generally, suppose $p > \frac{n}{2}$. Let $0 < \alpha < 1$ be such that $p > \frac{n}{2-\alpha}$. Then the inequality (15) still holds, with $C = C(n, p, \alpha)$. Thus we find that for $u \geq 0$ in B_R and*

$$\|\Delta u\|_{L^p(B_R)} = M, \quad p > \frac{n}{2}$$

then, in B_R ,

$$\frac{|u(x) - u(y)|}{|x - y|^\alpha} \leq C\left(\frac{u(0)}{R^\alpha} + MR^{2-\frac{n}{p}-\alpha}\right),$$

where $C = C(n, p, \alpha)$.

Section 4.

We extend Proposition 2 from Δ to second order elliptic operators with continuous coefficients. Consider

$$L = a_{ij}(x)\partial_{ij} + b_i(x)\partial_i + c(x),$$

where a_{ij}, b_i, c are continuous functions in the unit ball B_1 of \mathbb{R}^n , $c(x) \leq 0$ for all $|x| < 1$, and, for some constants $0 < \lambda \leq \Lambda < \infty$,

$$\lambda|\xi|^2 \leq a_{ij}(x)\xi^i\xi^j \leq \Lambda|\xi|^2, \quad \forall |x| < 1, \forall \xi \in \mathbb{R}^n.$$

The extension of Proposition 2 concerns some $W^{2,p}$, $p > 1$, nonnegative function u defined on $B_R \subset \mathbb{R}^n$ for some $R \leq \frac{1}{2}$.

Proposition 5. *Assume the above and*

$$\max |Lu| = M.$$

Then there is a constant C depending only on $n, \lambda, \Lambda, \|b_i\|_{L^\infty(B_{\frac{3}{4}})}, \|c\|_{L^\infty(B_{\frac{3}{4}})}$, and the modulus of continuity of $a_{ij}(x)$ in $B_{\frac{3}{4}}$ such that (4) and (5) hold.

Proof. For $0 < r \leq R$, let v be the solution of

$$Lv = 0 \text{ in } B_r, \quad v = u \text{ on } \partial B_r.$$

Then $w = v - u$ satisfies

$$|Lw| \leq M \text{ in } B_r, \quad w = 0 \text{ on } \partial B_r.$$

By the $W^{2,p}$ estimates, (6) holds, where, and from now on in the proof, C denotes various positive constants depending only on $n, \lambda, \Lambda, \|b_i\|_{L^\infty(B_{\frac{3}{4}})}, \|c\|_{L^\infty(B_{\frac{3}{4}})}$, and the modulus of continuity of $a_{ij}(x)$ in $B_{\frac{3}{4}}$. Estimate (7) follows from the Harnack inequality of Krylov and Safonov, see [1]. The rest of the proof is identical to the corresponding part of the proof of Proposition 2. \square

Section 5.

We extend Proposition 4 from Δ to operators L in Section 4. We assume $u \geq 0$ and

$$M = \|Lu\|_{L^p(B_R)}. \tag{16}$$

Proposition 6. *Let L be the operator in Section 4, we suppose $u \geq 0$ in B_R for some $R \leq \frac{1}{2}$ and (16) holds with some $p \in (\frac{n}{2}, n)$. Then for $x, y \in B_{\frac{R}{2}}, x \neq y$, and $\alpha = 2 - \frac{n}{p}$,*

$$\frac{|u(x) - u(y)|}{|x - y|^\alpha} \leq C \left(\frac{u(0)}{R^\alpha} + MR^{2 - \frac{n}{p} - \alpha} \right) \tag{17}$$

where C depends on $n, p, \lambda, \Lambda, \|b_i\|_{L^\infty(B_{\frac{3}{4}})}, \|c\|_{L^\infty(B_{\frac{3}{4}})}$, and the modulus of continuity of $a_{ij}(x)$ in $B_{\frac{3}{4}}$.

Proof. It is similar to that of Proposition 4, with the help of $W^{2,p}$ estimates for L and the Harnack inequality of Krylov and Safonov. \square

Remark 2. *If we take $p = n$ in Proposition 6, then by using the Hölder continuity estimate of Krylov and Safonov instead of the $W^{2,p}$ estimates in the proof of Proposition 6, inequality (17) holds for some positive constants α and C which depend on $n, p, \lambda, \Lambda, \|b_i\|_{L^\infty(B_{\frac{3}{4}})}$, and $\|c\|_{L^\infty(B_{\frac{3}{4}})}$, but independent of the modulus of continuity of a_{ij} .*

References

- [1] D. Gilbarg and N.S. Trudinger, *Elliptic partial differential equations of second order*, Reprint of the 1998 edition, Classics in Mathematics, Springer-Verlag, Berlin, 2001.
- [2] G. Glaeser, Racine carrée d'une fonction différentiable, *Ann. Inst. Fourier* **13** (1963), 203-207.
- [3] L. Nirenberg and F. Trèves, Solvability of a first order linear partial differential equation, *Comm. Pure Appl. Math.* **16** (1963), 331-351.

YanYan Li¹

Department of Mathematics
Rutgers University
110 Frelinghuysen Road
Piscataway, NJ 08854
USA

Louis Nirenberg
Courant Institute
251 Mercer Street
New York, NY 10012
USA

¹Partially supported by NSF grant DMS-0401118.

Nonexistence of Nontrivial Solutions for Supercritical Equations of Mixed Elliptic-Hyperbolic Type

Daniela Lupo, Kevin R. Payne and Nedyu I. Popivanov

Dedicated to Djairo de Figueiredo on the occasion of his 70th birthday

Abstract. For semilinear partial differential equations of mixed elliptic-hyperbolic type with various boundary conditions, the nonexistence of nontrivial solutions is shown for domains which are suitably star-shaped and for nonlinearities with supercritical growth in a suitable sense. The results follow from integral identities of Pohožaev type which are suitably calibrated to an invariance with respect to anisotropic dilations in the linear part of the equation. For the Dirichlet problem, in which the boundary condition is placed on the entire boundary, the technique is completely analogous to the classical elliptic case as first developed by Pohožaev [34] in the supercritical case. At critical growth, the nonexistence principle is established by combining the dilation identity with another energy identity. For “open” boundary value problems in which the boundary condition is placed on a proper subset of the boundary, sharp Hardy-Sobolev inequalities are used to control terms in the integral identity corresponding to the lack of a boundary condition as was first done in [23] for certain two dimensional problems.

1. Introduction

It is well known, starting from the seminal paper of Pohožaev [34], that the homogeneous Dirichlet problem for semilinear elliptic equations such as $\Delta u + u|u|^{p-2} = 0$ in Ω a bounded subset of \mathbf{R}^n , with $n \geq 3$, will permit only the trivial solution $u \equiv 0$ if the domain is star-shaped, the solution is sufficiently regular, and $p > 2^*(n) = 2n/(n-2)$ the critical exponent in the Sobolev embedding of $H_0^1(\Omega)$ into $L^p(\Omega)$ for $p \leq 2^*(n)$, which fails to be compact at the critical exponent. There are a vast number of extensions of this *nonexistence principle* to other elliptic equations and systems which forms an important part of nonlinear analysis with fruitful

links to concentration phenomena, blow-up arguments, and questions of compactness in variational problems (cf. [26] and the extensive bibliography therein). We mention explicitly only the pioneering work of de Figueiredo-Mitidieri on elliptic systems [8] and Brezis-Nirenberg [6] on the recovery of solutions at critical growth via a suitable linear perturbation. In dimension $n = 2$, the critical nonlinearity is of exponential type and strongly related to the Trudinger-Moser inequality (cf. [7] and the references therein). On the other hand, it has been shown by the first two authors in [23] that this nonexistence principle also holds for certain two dimensional problems of mixed elliptic-hyperbolic type. The point of this note is to show that the principle is valid for a large class of such problems even in higher dimensions.

In particular, we consider the nonexistence principle for boundary value problems of the form

$$Lu + F'(u) = 0 \quad \text{in } \Omega \quad (1.1)$$

$$u = 0 \quad \text{on } \Sigma \subseteq \partial\Omega \quad (1.2)$$

with $\Omega \subset \mathbf{R}^{N+1}$ a bounded open set with piecewise C^1 boundary, $F'(0) = 0$, and L a mixed type operator of Gellerstedt type

$$L = K(y)\Delta_x + \partial_y^2 \quad (1.3)$$

where $K(y) = y|y|^{m-1}$, $m > 0$ is a pure power type change function having the sign of y and $x \in \mathbf{R}^N$ with $N \geq 1$. In dimension 2 (where $N = 1$), such operators have a long standing connection with transonic fluid flow, a connection first established by Frankl' [11]. In addition, the operator (1.3) is related to problems of embedding manifolds whose curvature changes sign [17] and the operator has an associated singular metric of mixed Riemannian-Lorentzian signature which has been analyzed in [33]. Mixed signature metrics are of interest in the context of general relativity and quantum cosmology [14]. All such operators are invariant with respect to a certain anisotropic dilation which defines a suitable notion of star-shapedness by using the flow of the vector field which is the infinitesimal generator of the invariance.

We will consider both "open" and "closed" boundary value problems in the sense that Σ is either a proper subset or all of $\partial\Omega$ respectively. The nonexistence principle can, of course, be regarded as a uniqueness theorem for the trivial solution and it is well known that the presence of hyperbolicity in the equation (1.1) tends to overdetermine even linear problems with classical regularity. Hence, the nonexistence principle should be relatively easy in the case of the "closed" Dirichlet problem. We show this to be true in section 2 for general dimension $n = N + 1 \geq 2$. The argument follows closely that of the original argument in [34] for elliptic problems in which one: multiplies the equation by Mu where M generates the dilation invariance, integrates by parts over the domain, and controls the signs of the various volume and surface integrals. In addition, the result holds at critical growth by combining the dilation identity with another energy identity coming from the multiplier $Mu = u_y$. We note only the need for an additional

(and natural) geometric hypothesis on the boundary; namely, one needs that the hyperbolic portion of the boundary is *sub-characteristic* for the operator L (cf. formula (2.4)). The condition is natural for applications such as transonic flow in two dimensions where the hyperbolic boundary is the image under a hodograph transformation of either the physical boundary in the supersonic region or of a free boundary at the exit of a transonic nozzle, for example (cf. [4]).

For an “open” boundary value problem, the situation is more difficult. If Ω is star-shaped, one might suspect that the principle should hold for any Σ in which the linear problem has a uniqueness theorem. We have no counterexample as yet to this idea. In sections 3 and 4, we extend the results of [23] to various situations in which one knows such a uniqueness result; namely for the Frankl’ and Guderley-Morawetz problem in \mathbf{R}^2 and for the Protter problem in \mathbf{R}^{N+1} with $N \geq 2$. The results hold true for domains which are suitably star-shaped and whose boundary splits as $\Sigma_+ \cup \Sigma_- \cup \Gamma$ where the boundary condition is placed on the entire elliptic boundary Σ_+ and a proper subset Σ_- of the hyperbolic boundary which must be also sub-characteristic. The set Γ on which no data is placed is a piece of a characteristic surface. The lack of a boundary condition on Γ complicates the control of the corresponding boundary integral in the Pohožaev argument, but if Γ is characteristic and tangential to the dilation flow, a sharp Hardy-Sobolev inequality ensures that the contribution along Γ has the right sign, as was first done in [23].

In all cases, for the operator L in (1.3) the critical exponent phenomenon is of pure power type where p agrees with a critical Sobolev exponent in the embedding of a suitably weighted version of $H_0^1(\Omega)$ into $L^p(\Omega)$. This holds also in dimension $n = N + 1 = 2$ unlike the purely elliptic case, where $n > 2$. The point here is that the critical exponent associated to (1.3) feels the so-called *homogeneous dimension* $Q = 1 + (m + 2)N/2$ which is always larger than two for $m > 0$ and $N \geq 1$ (cf. section 3 of [24]).

Finally, in section 5, we consider the operator

$$L = K(y)\partial_{x_1}^2 + \partial_{x_2}^2 + \partial_y^2 \tag{1.4}$$

in \mathbf{R}^3 which was introduced by Bitsadze [5] in domains which are unbounded with respect to x_2 (in the Tricomi case where $K(y) = y$). In this way, one can think of x_2 as an auxiliary time variable and one can try to approach the 2-dimensional Gellerstedt equation as a steady state in a second order evolution equation. The operator (1.4) degenerates in a slightly different way with respect to the 3-dimensional Gellerstedt operator. The lack of a certain transversality property with respect to the type change surface $\{(x_1, x_2, y) \in \mathbf{R}^3 : y = 0\}$ allows us to verify the nonexistence principle only for exponents strictly larger than the critical Sobolev exponent in problems with an open boundary condition. On the other hand, for the (closed) Dirichlet problem, one does have the nonexistence principle with respect to the critical Sobolev exponent.

At the end of each section there are a few complementary remarks concerning comparisons with existence results. In section 6, we briefly discuss the critical

growth case for open boundary conditions and the regularity assumptions which gives an indication to further work along these lines.

2. The Dirichlet problem

In this section we show that the closed Dirichlet problem for the supercritical semi-linear Gellerstedt equation admits only the trivial solution. That is, we consider the problem

$$Lu + F'(u) = 0 \text{ in } \Omega \tag{2.1}$$

$$u = 0 \text{ on } \partial\Omega \tag{2.2}$$

where L is the Gellerstedt operator

$$L = K(y)\Delta_x + \partial_y^2, \quad K(y) = y|y|^{m-1}, \quad m > 0 \tag{2.3}$$

and Ω is an open, bounded, and connected subset of \mathbf{R}^{N+1} with piecewise C^1 boundary that is a *mixed type domain*; that is, $\Omega \cap \mathbf{R}_\pm^{N+1} \neq \emptyset$ where $\mathbf{R}_\pm^{N+1} = \{(x, y) \in \mathbf{R}^N \times \mathbf{R} : \pm y > 0\}$ are the *elliptic/hyperbolic half-spaces* for L . We will denote by $\Omega_\pm = \Omega \cap \mathbf{R}_\pm^{N+1}$, the *elliptic/hyperbolic regions*.

We begin by recalling a few notions which will be used throughout this work. The hyperbolic boundary $\Sigma_- = \partial\Omega \cap \mathbf{R}_-^{N+1}$ will be called *sub-characteristic* for the operator L if one has

$$K(y)|\nu_x|^2 + \nu_y^2 \geq 0, \text{ on } \Sigma_- \tag{2.4}$$

where $\nu = (\nu_x, \nu_y)$ is the (external) normal field on the boundary. Since $\partial\Omega$ is piecewise C^1 the normal field is well defined with the possible exception of a finite number of sets of zero surface measure which will create no essential difficulty in all that follows. If the inequality (2.4) holds in the strict sense, we will call Σ_- *strictly sub-characteristic* which just means that Σ_- is a piece of a *spacelike hypersurface* for the operator L which is hyperbolic for $y < 0$. The operator L in (2.3) is invariant with respect to the anisotropic dilation whose infinitesimal generator is

$$V = - \sum_{j=1}^N (m+2)x_j \partial_{x_j} - 2y \partial_y \tag{2.5}$$

(cf. section 2 of [24]). This dilation will be used to define a class of admissible domains for the nonexistence principle in the following way. Given a Lipschitz continuous vector field $V = - \sum_{j=1}^N \alpha_j(x, y) \partial_{x_j} - \beta(x, y) \partial_y$ on \mathbf{R}^{N+1} , one says that Ω is *V-star-shaped* if for every $(x_0, y_0) \in \overline{\Omega}$ the time t flow of (x_0, y_0) along V lies in $\overline{\Omega}$ for each $t \in [0, +\infty]$. If Ω is *V-star-shaped* then $\partial\Omega$ will be *V-star-like* in the sense that on $\partial\Omega$ one has

$$(\alpha, \beta) \cdot \nu \geq 0 \tag{2.6}$$

where $\alpha = (\alpha_1, \dots, \alpha_N)$ and ν is the external unit normal to $\partial\Omega$ (cf. Lemma 2.2 of [23]). If the inequality (2.6) holds in the strict sense, we will say that $\partial\Omega$ is *strictly V-star-like*. The differential operator L is also invariant with respect to

translations in the x variables, so one may normalize a given problem by assuming a particular location of the origin without loss of generality.

The dilation generated by V in (2.5) also gives rise to a critical exponent

$$2^*(N, m) = \frac{2[N(m + 2) + 2]}{N(m + 2) - 2} \tag{2.7}$$

for the embedding of the weighted Sobolev space $H_0^1(\Omega; m)$ into $L^p(\Omega)$ where

$$\|u\|_{H_0^1(\Omega; m)}^2 := \int_{\Omega} (|y|^m |\nabla_x u|^2 + u_y^2) \, dx dy \tag{2.8}$$

defines a natural norm for which to begin the search for weak solutions (cf. Proposition 2.4 of [23] and section 3 of [24]). More precisely, this norm is the natural norm for variational solutions where one notes that the equation (2.1) is the Euler-Lagrange equation associated to the functional $J(u) = \int_{\Omega} (\mathcal{L}(y, \nabla u) + F(u)) \, dx dy$ where

$$\mathcal{L}(y, \nabla u) = \frac{1}{2}(K(y)|\nabla_x u|^2 + u_y^2) \tag{2.9}$$

is the Lagrangian associated to L . With these preliminaries we can state the following result.

Theorem 2.1. *Let Ω be a mixed type domain which is star-shaped with respect to the generator V of the dilation invariance defined in (2.5) and whose hyperbolic boundary is sub-characteristic in the sense (2.4). Let $u \in C^2(\overline{\Omega})$ be a solution to (2.1)–(2.3) with $F'(u) = u|u|^{p-2}$. If $p > 2^*(N, m)$ the critical Sobolev exponent (2.7), then $u \equiv 0$. If, in addition, the noncharacteristic part of $\partial\Omega$ is strictly V -star-like, then the result holds also for $p = 2^*(N, m)$.*

Proof. Consider the primitive F satisfying $F(0) = 0$. One multiplies (2.1) by $Mu = -Vu$, integrates by parts, and uses the boundary condition $u = F(u) = 0$ on $\partial\Omega$ to find the Pohožaev type identity calibrated to the dilation invariance

$$\int_{\Omega} \left[(N(m + 2) + 2)F(u) - \frac{(N(m + 2) - 2)}{2} uF'(u) \right] \, dx dy = \int_{\partial\Omega} W \cdot \nu \, d\sigma \tag{2.10}$$

where

$$W = [(m + 2)x \cdot \nabla_x u + 2yu_y](K\nabla_x u, u_y) - \mathcal{L}((m + 2)x, 2y) \tag{2.11}$$

and \mathcal{L} is the Lagrangian defined in (2.9).

Assume that there exists a solution which is not identically zero. For the pure power nonlinearity $F'(u) = u|u|^{p-2}$ the integrand of the volume integral is negative if $p > 2^*(N, m)$. On the other hand, the surface integral is non-negative since $\partial\Omega$ is star-like in the sense (2.6) with $(\alpha, \beta) = ((m + 2)x, 2y)$, Σ_- is sub-characteristic, and $u = 0$ on $\partial\Omega$. In fact, the boundary condition implies that $\nabla u = (\partial u / \partial \nu)\nu$ on $\partial\Omega$ where $u_\nu = (\partial u / \partial \nu)$ is the normal derivative. One verifies easily that

$$W \cdot \nu = \frac{1}{2} u_\nu^2 (K|\nu_x|^2 + \nu_y^2) ((m + 2)x\nu_x + 2y\nu_y) \tag{2.12}$$

which is non-negative since Ω is star-shaped and Σ_- is sub-characteristic. This completes the proof for the supercritical case $p > 2^*(N, m)$.

In the critical case $p = 2^*(N, m)$, the volume integral in (2.10) vanishes while the integrand in surface integral is given by the nonnegative expression (2.12) which then must vanish. If one assumes that the noncharacteristic part of Ω is strictly V -star-like then (2.12) shows that

$$u_\nu^2 (K|\nu_x|^2 + \nu_y^2) = 0 \quad \text{on } \partial\Omega, \tag{2.13}$$

which implies, in particular, that the normal derivative u_ν vanishes on the elliptic boundary and at points of the hyperbolic boundary that are strictly sub-characteristic. This together with the vanishing of u on the boundary yields $u \equiv 0$ on $\bar{\Omega}$. In fact, using the $Mu = u_y$ multiplier identity (3.7) of [24] one has

$$\int_{\partial\Omega} \left(Ku_y \nabla_x u, \frac{1}{2}(u_y^2 - K|\nabla_x u|^2) + F(u) \right) \cdot \nu \, d\sigma = -\frac{m}{2} \int_{\Omega} |y|^{m-1} |\nabla_x u|^2 \, dx dy. \tag{2.14}$$

Using the boundary condition and $F(0) = 0$, the integrand of the surface integral in (2.14) becomes

$$\frac{1}{2} \nu_y u_\nu^2 (K|\nu_x|^2 + \nu_y^2)$$

which vanishes by (2.13). From (2.14) it then follows that $\nabla_x u = 0$ on Ω but since $u = 0$ on the boundary, one concludes $u \equiv 0$. □

Remarks:

1. As is usual, in place of the pure power nonlinearity $F(u) = |u|^p/p$ it suffices to have F satisfying $F(0) = 0$ and

$$(N(m + 2) + 2)F(u) - \frac{(N(m + 2) - 2)}{2} uF'(u) < 0 \quad \text{for } u > 0 \tag{2.15}$$

This is also the case in all of the results which follow, but will not be mentioned explicitly again.

2. It is clear that the arguments used above yield analogous results hold for degenerate hyperbolic operator $L = -|y|^m \Delta_x + \partial_y^2$ and for the degenerate elliptic operator $L = |y|^m \Delta_x + \partial_y^2$. In the degenerate elliptic case, the supercritical results are already known (cf. [31]) and extend to more general classes of degenerate elliptic operators with poly-homogeneous coefficients [27]. Many complementary results in the purely degenerate hyperbolic case are contained in [25]

3. As for the existence of solutions to the Dirichlet problem for subcritical growth, we only know what happens in the linear case ($Lu = f(x, y)$) for dimension two ($N = 1$) where the problem is weakly well-posed in $H_0^1(\Omega; m)$ for $f \in L^2(\Omega; |K|^{-1/2} dx dy)$ as is shown in the forthcoming paper [18].

3. Open boundary value problems in dimension 2

In this section, we give some simple extensions of the main results in [23] on the nonexistence principle for two dimensional problems of mixed type where the boundary condition is placed on a suitable proper subset of the boundary. More precisely, we consider the two dimensional version of problem (2.1)–(2.3)

$$K(y)u_{xx} + u_{yy} + F'(u) = 0 \text{ in } \Omega \tag{3.1}$$

$$u = 0 \text{ on } \Sigma \tag{3.2}$$

where $K(y) = y|y|^{m-1}$ with $m > 0$, Ω is a mixed type domain in the plane and $\Sigma \subset \partial\Omega$. In [23] we have proved the nonexistence principle for the *Tricomi problem* in which $\partial\Omega = \Sigma \cup \Gamma$ with $\Sigma = \sigma \cup AC$ and $\Gamma = BC$ where σ is an arc in the elliptic region and AC/BC are characteristics of L with negative/positive slopes respectively that meet in $C = (x_C, y_C)$; that is, with $x_A < x_B$,

$$AC := \{(x, y) \in \mathbf{R}^2 : y_C \leq y \leq 0; (m + 2)(x - x_A) = 2(-y)^{(m+2)/2}\} \tag{3.3}$$

$$BC := \{(x, y) \in \mathbf{R}^2 : y_C \leq y \leq 0; (m + 2)(x - x_B) = -2(-y)^{(m+2)/2}\}. \tag{3.4}$$

Now we consider two other problems which possess a uniqueness theorem for the linear equation. The first is the *Frankl' problem* in which one characteristic arc, say AC , is replaced by a sub-characteristic arc Γ_1 connecting A to some point, which we will still call C , on the characteristic of positive slope through B . We call such a domain a *Frankl' domain*. Since the operator $L = y|y|^{m-1}\partial_x^2 + \partial_y^2$ is invariant with respect to translations in x , we may assume, without loss of generality, that the point $B = (x_B, 0) \in \bar{\Omega}$ with maximal x -coordinate on the parabolic segment is situated at the origin; that is, $B = (0, 0)$. The following result contains Theorem 4.2 of [23] in the case that $\Gamma_1 = AC$ is everywhere characteristic.

Theorem 3.1. *Let $\Omega \subset \mathbf{R}^2$ be a Frankl' domain with boundary $\sigma \cup \Gamma_1 \cup BC$ with Γ_1 sub-characteristic for L . Assume that Ω is star-shaped with respect to the generator V of the dilation invariance for L . Let $u \in C^2(\bar{\Omega})$ be a solution to (3.1)–(3.2) with $\Sigma = \sigma \cup \Gamma_1$ and $F'(u) = u|u|^{p-2}$. If $p > 2^*(1, m) = 2(m + 4)/m$ the critical Sobolev exponent, then $u \equiv 0$.*

Proof. The proof is exactly like that for the Tricomi problem (Theorem 4.2 of [23]), but for completeness we briefly sketch the proof. We remark that the flow of V is tangential to the characteristic BC and hence the hypothesis that Ω is V -star-shaped imposes a restriction only on $\sigma \cup \Gamma_1$. Consider the primitive F with $F(0) = 0$. The Pohožaev identity calibrated to the dilation invariance in this case is (cf. Theorem 3.1 of [23]):

$$\int_{\Omega} \left[(m + 4)F(u) - \frac{m}{2}uF'(u) \right] dx dy = \int_{\sigma \cup \Gamma_1} W_1 \cdot \nu ds + \int_{BC} (W_1 + W_2) \cdot \nu ds \tag{3.5}$$

where

$$W_1 = [(m + 2)xu_x + 2yu_y](Ku_x, u_y) - \frac{1}{2}[Ku_x^2 + u_y^2]((m + 2)x, 2y) \tag{3.6}$$

$$W_2 = F(u)((m + 2)x, 2y) + \frac{m}{2}u(Ku_x, u_y). \tag{3.7}$$

For supercritical p , the area integral is negative for a non trivial u . As for the boundary integrals, the W_1 terms are the usual ones corresponding to (2.11) while the W_2 term is “new” and reflects the fact that the boundary condition is not imposed on BC . The integral over $\sigma \cup \Gamma_1$ is non negative since the formula (2.12) applies on $\sigma \cup \Gamma_1$. After choosing the parametrization $\gamma(t)$ of the characteristic BC defined in (3.4) with t equals y as parameter, integration by parts shows that

$$\int_{BC} (W_1 + W_2) \cdot \nu \, ds = \int_{y_C}^0 \left[4(-t)^{(m+2)/2} \psi'(t)^2 - \frac{m^2}{4} (-t)^{(m-2)/2} \psi^2(t) \right] dt \tag{3.8}$$

where $\psi(t) := u(\gamma(t)) \in C^2((y_C, 0)) \cap C^1([y_C, 0])$. The non-negativity of (3.8) is equivalent to the validity of a Hardy-Sobolev inequality for ψ of the form

$$\int_{y_C}^0 \psi^2(t)w(t) \, dt \leq C_L^2 \int_{y_C}^0 (\psi'(t))^2v(t) \, dt \tag{3.9}$$

with weights $w(t) = (-t)^{(m-2)/2}$ and $v(t) = (-t)^{(m+2)/2}$ where one also needs that the best constant C_L in the inequality satisfies $C_L^2 \leq 16/m^2$. Lemma 4.3 of [23] provides exactly this result which is a transcription of a result of Opic and Kufner (Theorem 1.14 of [32]). This completes the proof. \square

The same proof works for the *Guderley-Morawetz problem* in which one takes a simply bounded open and connected set $\tilde{\Omega}$ (containing the origin, say) and removes the *solid backward light cone with vertex at the origin*

$$\bar{K}(0) = \{(x, y) \in \mathbf{R}^2 : (m + 2)^2x^2 \leq 4(-y)^{m+2}, y \leq 0\} \tag{3.10}$$

Call Ω the resulting *Guderley-Morawetz domain*. Its boundary will consist of $\sigma \cup \Gamma_1 \cup \Gamma_2 \cup BC_1 \cup BC_2$ where σ is the elliptic boundary which joins A_1 to A_2 on the parabolic line, Γ_j are sub-characteristic arcs descending from A_j which meet the characteristics BC_j forming the boundary of (3.10) at the points C_j . The boundary value problem is to solve (3.1) – (3.2) where $\Sigma = \sigma \cup \Gamma_1 \cup \Gamma_2$. The result is the following theorem which contains Theorem 3.1 in the limit when A_2 tends to B .

Theorem 3.2. *Let $\Omega \subset \mathbf{R}^2$ be a Guderley-Morawetz domain with boundary $\sigma \cup \Gamma_1 \cup \Gamma_2 \cup BC_1 \cup BC_2$, where Γ_1, Γ_2 are sub-characteristic. Assume that Ω is star-shaped with respect to the generator V of the dilation invariance for L . Let $u \in C^2(\bar{\Omega})$ be a solution to (3.1)–(3.2) with $\Sigma = \sigma \cup \Gamma_1 \cup \Gamma_2$ and $F'(u) = u|u|^{p-2}$. If $p > 2^*(1, m) = 2(m + 4)/m$ the critical Sobolev exponent, then $u \equiv 0$.*

Remarks:

1. These boundary value problems (Tricomi, Frankl’, and Guderley-Morawetz) in the linear case are the classical boundary value problems that appear in hodograph plane for 2-D transonic potential flows (cf. Section 6 of [24], [4], [30]). The first two for flows in nozzles and jets and the third as an approximation in flows about airfoils (the real problem is the closed Dirichlet problem). Existence

of *weak solutions* and uniqueness of *strong solutions* in weighted Sobolev spaces for the Guderley-Morawetz problem were first established by Morawetz [29] by reducing the problem to a first order system which then give rise to solutions to the scalar equation in the presence of sufficient regularity. Such regularity comes from the work of Lax and Philips [16] who also established that the weak solutions of Morawetz are strong (see also the discussion at the end of section 6). All these linear problems have suitable uniqueness theorems that we have shown give rise to a Pohožaev nonexistence principle for supercritical nonlinear variants if the domains are suitably star-shaped. The key ingredient is that the curves on which the boundary condition is not imposed are characteristics which are tangential to the flow generated by the dilation invariance.

2. With respect to existence, one knows that weak solutions exist for the linear problem under suitable hypotheses on Σ . In particular, one has weak existence and uniqueness in $H^1(\Omega)$ ($H^1(\Omega; m)$ with norm (2.8)) for *angular (normal)* domains in which the elliptic arc meets the parabolic line in acute (right) angles since the technique of Didenko [9] employed in [19] ([20]) for angular (normal) Tricomi problems carries over without substantial changes to these problems with open boundary conditions. Moreover, for certain sub-critical nonlinearities $F'(u)$ the first two authors have shown the existence of weak solutions for the semi-linear Tricomi problem (cf. [22]). Some of these results depend on spectral information [21] on the linear part which in turn depends on a variant [20] (compatible with a weak existence theory) of the classical maximum principle of Agmon, Nirenberg and Protter [1]. The proof of this classical maximum principle requires that the part of the hyperbolic boundary carrying the boundary data be characteristic. Hence one could extend the existence results of [22] which are independent of the maximum principle to the semi-linear Frankl' and Guderley-Morawetz problems.

4. The Protter problem in higher dimensions

In this section, we consider a generalization of the semi-linear Guderley-Morawetz problem to higher dimensions. More precisely, we consider the problem

$$Lu + F'(u) = 0 \text{ in } \Omega \tag{4.1}$$

$$u = 0 \text{ on } \Sigma \tag{4.2}$$

where L is the Gellerstedt operator (2.3) on a bounded open mixed domain $\Omega \subset \mathbf{R}^{N+1}$, $N \geq 2$, and the hyperbolic part of the domain $\Omega_- = \Omega \cap \mathbf{R}_-^{N+1}$ has the particular form

$$\Omega_- = \left\{ (x, y) \in \mathbf{R}^N \times \mathbf{R} : \frac{2}{m+2}(-y)^{(m+2)/2} \leq |x| \leq R - \frac{2}{m+2}(-y)^{(m+2)/2}, y \leq 0 \right\} \tag{4.3}$$

The ‘‘lateral boundaries’’ of Ω_- are characteristic surfaces. The outer part Σ_- , where $(m+2)^2(|x|-R)^2 = 4(-y)^{m+2}$, is the boundary of the domain of dependence

of the point $(0, -((m+2)R/2)^{2/(m+2)})$ while the inner part Γ , where $(m+2)^2|x|^2 = 4(-y)^{m+2}$, is the boundary of the backward light cone with vertex at the origin. Such a domain will be called a *Protter domain* and the Protter problem consists in putting boundary data on the entire elliptic boundary Σ_+ and the portion Σ_- of the hyperbolic boundary. Protter proposed these boundary conditions in three dimensions (when $N = 2$) for the linear equation (cf. [39]) as an analog to the planar Guderley-Morawetz problem, but even in the linear case a general understanding is not at hand (see the remarks at the end of the section). Here we show that the nonexistence principle is valid for the semi-linear Protter problem for the Gellerstedt equation in general dimension.

Theorem 4.1. *Let $\Omega \subset \mathbf{R}^{N+1}$ be a Protter domain with boundary $\Sigma_+ \cup \Sigma_- \cup \Gamma$. Assume that Ω is star-shaped with respect to the generator V of the dilation invariance for L . Let $u \in C^2(\bar{\Omega})$ be a solution to (4.1)–(4.2) with $\Sigma = \Sigma_+ \cup \Sigma_-$ and $F'(u) = u|u|^{p-2}$. If $p > 2^*(N, m)$ the critical Sobolev exponent (2.7), then $u \equiv 0$.*

Proof. The argument is a simple modification of the proofs already given. We note that the hyperbolic region is automatically V -star-shaped and so there are restrictions only on the geometry of the boundary in the elliptic region. The Pohožaev identity calibrated to the dilation is

$$\begin{aligned} & \int_{\Omega} \left[(N(m+2) + 2)F(u) - \frac{(N(m+2) - 2)}{2} uF'(u) \right] dx dy \\ &= \int_{\Sigma} W_1 \cdot \nu d\sigma + \int_{\Gamma} (W_1 + W_2) \cdot \nu d\sigma \end{aligned} \tag{4.4}$$

where $W_1 = W$ is the expression (2.11) in the Dirichlet case and

$$W_2 = F(u)((m+2)x, 2y) + \frac{N(m+2) - 2}{2} u(K\nabla_x u, u_y) \tag{4.5}$$

is the expression analogous to (3.7) coming from the lack of the boundary condition on Γ . The volume integral is negative for p supercritical and the integral over Σ is non-negative just as in the Dirichlet case where in fact the contribution coming from the characteristic surface Σ_- is zero (see formula (2.12)). This leaves the integral over the characteristic surface Γ where no boundary condition has been imposed. Using that the dilation flow is tangential to Γ one sees that on Γ

$$W_1 + W_2 = \left[(m+2)(x \cdot \nabla_x u) + 2yu_y + \frac{N(m+2) - 2}{2} u \right] (K\nabla_x u, u_y).$$

Writing Γ as a graph

$$y = g(x) = - \left[\frac{m+2}{2} |x| \right]^{2/(m+2)}, \quad x \in B_{R/2}(0),$$

where $B_{R/2}(0)$ is the ball of radius $R/2$ centered in the origin, and using that the dilation flow is tangential along Γ one finds that the integrand in (4.4) is

$$(W_1 + W_2) \cdot \nu d\sigma = \left[(m + 2)(x \cdot \nabla_x u) + 2yu_y + \frac{N(m + 2) - 2}{2}u \right] [(K\nabla_x u \cdot \nabla g) - u_y] dx$$

where K, u and the derivatives of u are evaluated in $(x, g(x))$. Setting $\varphi(x) = u(x, g(x))$ and $r = |x|$, one sees that the radial derivative $\varphi_r := (x \cdot \nabla \varphi)/|x|$ satisfies

$$(m + 2)r\varphi_r = (m + 2)(x \cdot \nabla_x u) + 2yu_y$$

and then using polar coordinates and Fubini's theorem gives

$$\int_{\Gamma} (W_1 + W_2) \cdot \nu d\sigma = \left(\frac{m + 2}{2} \right)^{m/(m+2)} \int_{S^{N-1}} \left(\int_0^{R/2} ((m + 2)r^\alpha \varphi_r^2 + C_{N,m} r^{\alpha-1} \varphi \varphi_r) dr \right) d\omega_{N-1} \tag{4.6}$$

where ω_{N-1} is surface measure on the sphere S^{N-1} and

$$\alpha = \frac{N(m + 2) + m}{m + 2}, \quad C_{N,m} = \frac{N(m + 2) - 2}{2}. \tag{4.7}$$

Hence it suffices to show that for each direction on S^{N-1} the inner integral in (4.6) is non-negative. An integration by parts in the $\varphi \varphi_r$ term plus the change of variables $t = -r$ with $\psi(t) = \varphi(-t)$ shows that the non negativity of the inner integral is equivalent to the inequality

$$\int_{-R/2}^0 (-t)^{\alpha-2} \psi^2(t) dt \leq \frac{4}{(\alpha - 1)^2} \int_{-R/2}^0 (-t)^\alpha \psi'(t)^2 dt \tag{4.8}$$

with α given by (4.7) and $\psi \in C^2((-R/2, 0)) \cap C^1([-R/2, 0])$ vanishing at the left hand endpoint. This is precisely the aforementioned Hardy-Sobolev inequality (3.9) with α playing the role of $(m + 2)/2$ in that formula. This completes the proof. \square

Remarks:

1. From the proof, it is clear that one has the nonexistence principle for the Protter problem in a slightly more general class of domains. Namely, take a mixed domain $\tilde{\Omega}$ which contains the origin and is star-shaped with respect to the dilation flow. Remove the solid backward light cone with vertex at the origin $\bar{\mathcal{K}}(0)$ from $\tilde{\Omega}$ and call the difference Ω which has boundary $\Sigma \cup \Gamma$. The hypersurface Σ which carries the boundary data splits into an elliptic and hyperbolic part $\Sigma_+ \cup \Sigma_-$ and instead of assuming that Σ_- is characteristic, we now assume that Σ_- is a sub-characteristic graph; that is, $y = h(x)$ for $x \in D$ with

$$K(h(x))|\nabla_x h(x)|^2 + 1 \geq 0, \quad x \in D. \tag{4.9}$$

The integral over the characteristic surface Γ in polar coordinates then yields the expression (4.6) with some function $R(\omega)$ in place of $R/2$ where $\omega \in S^{N-1}$. The Hardy-Sobolev inequality for each ω fixed would then finish the proof.

2. Even in the linear case, the question of well posedness is surprisingly subtle and not completely resolved (see [38] and [2] and the references cited therein). One has uniqueness results for *quasi-regular* solutions [3], a class of solutions introduced by Protter, but there are real obstructions to existence in this class. For example, consider the problem in \mathbf{R}^3 which is the natural analog to the two dimensional degenerate hyperbolic Darboux problem; that is consider $\Omega = \Omega_-$ in which the domain consists only of its hyperbolic part. It was shown in [36] that the homogeneous adjoint problem admits infinitely many nontrivial classical solutions $v_n \in C^n(\bar{\Omega})$, $n \in \mathbf{N}$. This implies that for classical solvability of the linear Protter problem in a hyperbolic domain $\Omega = \Omega_-$ there are an infinite number of side conditions of the form $f \perp v_n$ which must be satisfied by the right hand side f in the equation. The concept of a *generalized solution* with a possible singularity on the inner cone Γ was introduced in [38] and results in weak well-posedness in this class when $\Omega = \Omega_-$. In addition, [38] contains the construction of a sequence of unique generalized solutions u_n with $Lu_n \in C^n(\bar{\Omega})$ but which presents a strong singularity at the vertex of the cone Γ . The order of the strong singularity of u_n grows with n to infinity. Despite the introduction of numerous techniques, such as nonlocal regularization (cf. [10] and the references therein), the problem of existence of weak solutions for a large class of f in a mixed elliptic-hyperbolic domain remains open. It is also an open question if the strong ill-posedness described above for a hyperbolic domain $\Omega = \Omega_-$ is also present in mixed elliptic-hyperbolic domains. Finally, we note that uniqueness for the Protter problem with $\Omega_- \subset \mathbf{R}^4$ in the case of the wave equation has been shown by Garabedian [13].

5. Lateral degeneration: a model problem in dimension 3

In this section, we will discuss the nonexistence principle for a semi-linear problem (1.1) – (1.2) in three dimensions involving the differential operator

$$L = K(y)\partial_{x_1}^2 + \partial_{x_2}^2 + \partial_y^2 \tag{5.1}$$

introduced in (1.4) where as always $K(y) = y|y|^{m-1}$ with $m > 0$. Before proceeding with the results, we discuss the essential differences between this operator and the class previously considered. The operator in (5.1) is again of mixed elliptic-hyperbolic type where $y = 0$ again gives the type change interface. However, the degeneration in (5.1) is qualitatively different from that of the Gellerstedt operator $L_G = K(y)[\partial_{x_1}^2 + \partial_{x_2}^2] + \partial_y^2$. By denoting $t = y$ one can rewrite L_G as

$$L_G = \partial_t^2 + K(t)(\partial_{x_1}^2 + \partial_{x_2}^2) \tag{5.2}$$

which for $t = y < 0$ is a wave operator with variable speed $c = [-K(t)]^{1/2}$, which tends to 0 as $t \rightarrow 0^-$. So the type change surface is transversal to the axis of the time-like variable $t = y$. The form (5.2) is a canonical form for the

hyperbolic operator L_G (it has the form $\partial_t^2 - \sum_{i,j=1}^2 a_{ij}(x,t)\partial_{x_i}\partial_{x_j}$ with $[a_{ij}]$ positive definite). On the other hand, for the operator L the best we can do comes from $(x_1, x_2, t) = (y, x_2, x_1)$ yielding $L = K(x_1)\{\partial_t^2 - [-K(x_1)]^{-1}(\partial_{x_1}^2 + \partial_{x_2}^2)\}$ which is a wave operator whose speed depends on a space-like variable $x_1 = y$ and tends to infinity at the type change interface. We call this a *lateral degeneration* as the degeneration takes place with respect to a space-like coordinate and light cones are naturally oriented with respect to x as a time axis.

This lack of transversality between the type change interface and the time-like variable manifests itself in a way that complicates the nonexistence principle. For the operator (5.1) there is not a full 3-D light cone which traces back from a point P on $y = 0$ into the hyperbolic region (a domain of dependence for P). On each characteristic of L which passes through $(x_1, x_2, y) = (x'_1, x'_2, 0)$ one has $x_2 \equiv x'_2$ constant. For our proof of the nonexistence principle for an open boundary value problem, we need that the surface Γ on which the data is not placed be characteristic and tangential to a flow generated by the invariance of L with respect to dilation. This is not possible for the operator (5.1). We can, however, exploit a two dimensional dilation flow (which is not an invariance in general) to obtain the nonexistence principle for a range of exponents above the critical Sobolev exponent.

We now begin the analysis. Associated to the operator L in (5.1), which again has an associated Lagrangian, we have the natural Sobolev space $\tilde{H}_0^1(\Omega; m)$ which is the completion of $C_0^\infty(\Omega)$ with respect to the norm

$$\|u\|_{\tilde{H}_0^1(\Omega; m)}^2 = \int_{\Omega} (|K(y)|u_{x_1}^2 + u_{x_2}^2 + u_y^2) dx_1 dx_2 dy. \tag{5.3}$$

Solutions to $Lu = 0$ are invariant under the anisotropic dilation

$$u_\lambda(x_1, x_2, y) = u(\lambda^{(m+2)}x_1, \lambda^2x_2, \lambda^2y), \quad \lambda > 0 \tag{5.4}$$

whose infinitesimal generator is $\tilde{M}u = (m + 2)x_1u_{x_1} + 2x_2u_{x_2} + 2yu_y$. This invariance shows that the critical Sobolev exponent in the embedding of $\tilde{H}_0^1(\Omega; m)$ into $L^p(\Omega)$ is

$$p = 2^{**}(m) = \frac{2(m + 6)}{m + 2}. \tag{5.5}$$

Let $\Omega \subset \mathbf{R}^3$ be a bounded open set with piecewise C^1 boundary $\partial\Omega = \Sigma_+ \cup \Sigma_- \cup \Gamma$ where $\Sigma_+ = \partial\Omega \cap \mathbf{R}_+^3$ is the elliptic boundary, Γ is a piece of the characteristic surface defined by

$$(m + 2)x_1 = -2(-y)^{(m+2)/2}, \quad x'_2 \leq x_2 \leq x''_2, \quad y_1(x_2) \leq y \leq y_2(x_2), \tag{5.6}$$

where $y_1, y_2 \leq 0$ are C^1 functions of x_2 . We note the strongest result corresponds to having Γ as large as possible since no boundary condition is imposed on Γ ; that is, with $y_2 = 0$. We assume that Σ_- is a *sub-characteristic surface* with respect to L ; that is,

$$K(y)\nu_{x_1}^2 + \nu_{x_2}^2 + \nu_y^2 \geq 0 \tag{5.7}$$

holds on Σ_- where $\nu = (\nu_{x_1}, \nu_{x_2}, \nu_y)$ is the (external) field on $\partial\Omega$. Again, we will say that Σ_- is *strictly sub-characteristic* if (5.7) holds in the strict sense. We consider the problem

$$Lu + u|u|^{p-2} = 0 \text{ in } \Omega \tag{5.8}$$

$$u = 0 \text{ on } \Sigma_+ \cup \Sigma_- \tag{5.9}$$

The main result is the following nonexistence principle.

Theorem 5.1. *Let $u \in C^2(\overline{\Omega})$ be a solution of (5.8)–(5.9) with L given by (5.1). Assume that Ω is star-shaped with respect to the 2-dimensional dilation flow generated by the vector field $V = -M = -(m + 2)x_1\partial_{x_1} - 2y\partial_y$ and that Σ_- is sub-characteristic. If*

$$p \geq 2^*(m) := \frac{2m + 8}{m} \tag{5.10}$$

then $u \equiv 0$. In particular, the result holds at the critical exponent without further hypotheses on the boundary geometry.

Comparing (5.5) and (5.10) one sees that $2^*(m) > 2^{**}(m)$ and so the nonexistence holds at exponents strictly larger than what one expects in general. One notes that the gap $2^*(m) - 2^{**}(m) = 16/(m^2 + 2m)$ tends to zero as m tends to infinity, so both exponents are nearly 2 for large m . On the other hand, the exponent (5.10) is exactly the 2-D critical exponent of section 2 and hence one sees that for solutions independent of x_2 one does recover the expected result.

Proof. The Pohožaev identity using the 2-D multiplier $Mu = (m + 2)x_1u_{x_1} + 2yu_y$ and the boundary condition is

$$\begin{aligned} & \int_{\Omega} \left[(m + 4)F(u) - \frac{m}{2}uF'(u) \right] dx_1dx_2dy \\ &= \int_{\Omega} 2u_{x_2}^2 dx_1dx_2dy + \int_{\Sigma} U_1 \cdot \nu d\sigma + \int_{\Gamma} U_2 \cdot \nu d\sigma \end{aligned} \tag{5.11}$$

where $F(u) = |u|^p/p$ and

$$U_1 = [(m + 2)x_1u_{x_1} + 2yu_y](Ku_{x_1}, u_{x_2}, u_y) - \frac{1}{2}[Ku_{x_1}^2 + u_{x_2}^2 + u_y^2]((m + 2)x_1, 0, 2y) \tag{5.12}$$

$$U_2 = [(m + 2)x_1u_{x_1} + 2yu_y + mu/2](Ku_{x_1}, u_{x_2}, u_y) \tag{5.13}$$

where we have used the boundary conditions and the fact that V is tangential to Γ . Notice the presence of the volume integral on the right hand side of (5.11) which is due to the fact that M does not generate in general an invariance for L (unless $u_{x_2} \equiv 0$). This “extra term” is non-negative and hence has the correct sign. The left hand side is non positive and we claim that the boundary integrals are non-negative using the boundary conditions, the assumptions on the boundary geometry, and the sharp Hardy-Sobolev inequality on Γ (where no boundary condition is imposed). Hence from (5.11) it follows that $u_{x_2} \equiv 0$ on Ω and then that $u \equiv 0$.

It remains to prove the claim that the boundary integrals are non negative. On Σ where $u = 0$, we have $\nabla u = (\partial u / \partial \nu)\nu$ and hence

$$U_1 \cdot \nu = u_\nu^2 [(m + 2)x_1 \nu_{x_1} + 2y \nu_y] [K \nu_{x_1}^2 + \nu_{x_2}^2 + \nu_y^2] \geq 0 \text{ on } \Sigma,$$

since Σ is V -star-like and Σ_- is sub-characteristic. Now consider the directional derivative $\partial_+ u = u_y + (-y)^{m/2} u_{x_1}$ which is essentially the tangential derivative along Γ in the direction of increasing y and note that $\nu = (1 + (-y)^m)^{-1/2} (1, 0, -(-y)^{m/2})$ on Γ . By parameterizing Γ with (x_2, y) and setting $\varphi(x_2, y) = u(g(y), x_2, y) = u(-2(m + 2)^{-1}(-y)^{(m+2)/2}, x_2, y)$, one has that $\varphi_y(x_2, y) = \partial_+ u(g(y), x_2, y)$ and hence

$$\begin{aligned} \int_\Gamma U_2 \cdot \nu \, d\sigma &= \int_{x'_2}^{x''_2} \left\{ \int_{y_1(x_2)}^{y_2(x_2)} \left[4(-y)^{(m+2)/2} \varphi_y^2 - m(-y)^{m/2} \varphi \varphi_y \right] dy \right\} dx_2 \\ &= \int_{x'_2}^{x''_2} \left\{ \int_{y_1(x_2)}^{y_2(x_2)} \left[4(-y)^{(m+2)/2} \varphi_y^2 - \frac{m^2}{4} (-y)^{(m-2)/2} \varphi^2 \right] dy \right\} dx_2, \end{aligned}$$

because $\varphi(x_2, y) = 0$ on the endpoints $y = y_1(x_2)$ and $y = y_2(x_2)$. This last integral is non-negative due to the Hardy-Sobolev inequality (3.9) for each fixed x_2 . This completes the proof. \square

We conclude the results of this section by noting that the analog to Theorem 2.1 on the (closed) Dirichlet problem also holds for the operator L defined by (5.1).

Theorem 5.2. *Let Ω be mixed type domain which is star-shaped with respect to the generator $\tilde{V} = -(m + 2)x_1 \partial_{x_1} - 2x_2 \partial_{x_2} - 2y \partial_y$ of the dilation invariance defined in (5.4) and whose hyperbolic boundary is sub-characteristic in the sense (5.7). Let $u \in C^2(\bar{\Omega})$ be a solution to (5.8) with $u = 0$ on $\partial\Omega$. If $p > 2^{**}(m)$ the critical Sobolev exponent (5.5), then $u \equiv 0$. If, in addition, the noncharacteristic part of $\partial\Omega$ is strictly \tilde{V} -star-like, then the result holds also for $p = 2^{**}(m)$.*

Proof. Again selecting the primitive F with $F(0) = 0$, the Pohožaev identity calibrated to $\tilde{M}u = -\tilde{V}u$ is

$$\int_\Omega \left[(m + 6)F(u) - \frac{m + 2}{2} u F'(u) \right] dx_1 dx_2 dy = \int_{\partial\Omega} \tilde{U} \cdot \nu \, d\sigma \tag{5.14}$$

where $F(u) = |u|^p / p$ and

$$\begin{aligned} \tilde{U} &= [(m + 2)x_1 u_{x_1} + 2x_2 u_{x_2} + 2y u_y] (K u_{x_1}, u_{x_2}, u_y) \\ &\quad - \frac{1}{2} [K u_{x_1}^2 + u_{x_2}^2 + u_y^2] ((m + 2)x_1, 2x_2, 2y). \end{aligned} \tag{5.15}$$

The volume integral is now non positive for $p \geq 2^{**}(m)$. Then, using the boundary condition, one has $\nabla u = (\partial u / \partial \nu)\nu$ and hence

$$\tilde{U} \cdot \nu = \frac{1}{2} u_\nu^2 [K \nu_{x_1}^2 + \nu_{x_2}^2 + \nu_y^2] [((m + 2)x_1, 2x_2, 2y) \cdot \nu]$$

which is non negative under the boundary geometry hypotheses and the theorem follows using the ideas previously presented. \square

Remarks:

1. As for existence results in the linear case, Karatoprakliev [15] has shown the existence of weak solutions and the uniqueness of strong solutions under strong assumptions on the geometry of the boundary Σ . These boundary geometry restrictions were removed and well-posedness was established in $W_2^1(\Omega)$ by the third author [35] for both the Tricomi and Frankl' problems under the sole assumption that Σ_- is (not necessarily strictly) sub-characteristic.

2. For weakly nonlinear $F'(u)$, one has the existence and uniqueness of generalized solutions in the space $\tilde{H}_0^1(\Omega; m)$, defined by (5.3), for the semilinear problem as has been shown in [37].

6. Concluding remarks

In this section, we collect a few remarks concerning the critical growth case and the regularity of the solutions considered herein which gives an indication of possible extensions. As for the critical growth case, we note that in the classical elliptic case of the Dirichlet problem for $L = \Delta$, one uses the strictly starlike assumption on the boundary to arrive at $u = u_\nu = 0$ on the boundary and then employs a unique continuation argument to show that $u \equiv 0$ (see [40], for example). This requires some additional regularity on the boundary with respect to that needed for the validity of the dilation energy identity. Our proof for the Dirichlet problem with the Gellerstedt operator (which works equally well for the degenerate elliptic/hyperbolic operators $\partial_y^2 \pm |y|^m \Delta_x, m > 0$) uses instead the u_y multiplier identity which adds no additional requirements on the boundary regularity. It should be noted that this is a ‘hyperbolic technique’ in the sense that the u_y multiplier identity is the analog of the u_t multiplier identity for non degenerate hyperbolic equations yields the conservation of total energy along time slices. In our degenerate situation, this is not a conservation law, but it is not ‘far’ from being one and yields energy decay for increasing $y < 0$ for the Gellerstedt operator (cf. section 5 of [24]). On the other hand, for problems with open boundary conditions (such as Theorems 3.1, 3.2, and 4.1) the absence of the boundary condition on a part Γ of the boundary prevents a direct global application of the identity. One can combine the unique continuation idea in the elliptic region with a localization of the u_y identity on backward light cones to reduce the problem in two dimensions to the question of uniqueness for the Goursat (Darboux) problem (or an analog of it in higher dimensions) for the degenerate hyperbolic operator. For the nonlinearity $F'(u) = Cu|u|^{p-2}$ with $C \leq 0$ in two dimensions, the uniqueness has been established in Theorem 4.3 of [24] using the dilation variant of Morawetz's conservation laws technique [28]. Uniqueness of the trivial solution in the critical growth Goursat (Darboux) problem with $C > 0$ thus remains open. Finally, we note that in the problems for which we do not yet have the result for the pure

power critical growth $F'(u) = u|u|^{2^*-2}$, the nonexistence principle does hold for the perturbation $F'(u) = u|u|^{2^*-2} - \lambda u$ with $\lambda > 0$.

With respect to the regularity of solutions, we have assumed throughout this work that the solutions are of class $C^2(\overline{\Omega})$, which is clearly too much. In fact, even for problems with open boundary conditions one expects, in general, to have the possibility of isolated singularities in the first derivatives at parabolic boundary points. This is compatible with the weighted norms like (2.8) in which it is natural to find solutions. Moreover, for semilinear problems of the form (1.1) – (1.2) with subcritical growth and with L given by (1.3) or (1.4), known existence results are usually, but not always, for *generalized solutions* in the sense that (for (1.3) for example): there exists $u \in H^1_{\Sigma}(\Omega; m)$ for which

$$\int_{\Omega} [K(y)(\nabla_x u \cdot \nabla_x \varphi) + u_y \varphi_y + F'(u)\varphi] \, dx dy = 0 \quad \forall \varphi \in H^1_{\Sigma_1 \cup \Gamma}(\Omega; m) \quad (6.1)$$

where $\partial\Omega = \Sigma \cup \Gamma = \Sigma_1 \cup \Sigma_{\text{char}} \cup \Gamma$ with Γ a piece of a characteristic surface not carrying the boundary condition and Σ_1 the noncharacteristic part of the boundary carrying the boundary condition. The Sobolev spaces are the closures with respect to the norm (2.8) of smooth functions vanishing near the relevant boundary portion.

On the other hand, one would hope to be able to establish the nonexistence for supercritical problems in the class of *strong solutions* $u \in H^1_{\Sigma}(\Omega; m)$ in the sense that: there exists a sequence $\{u_j\} \subset C^2_{\Sigma}(\overline{\Omega})$ such that

$$\lim_{j \rightarrow +\infty} \|u_j - u\|_{H^1(\Omega; m)} = 0 = \lim_{j \rightarrow +\infty} \|Lu_j - F'(u_j)\|_{L_2(\Omega)} \quad (6.2)$$

This is the case, for example, for the results in [23]. The problem arises that the convergence asked for in (6.2) is stronger than the convergence which comes for free from the existence of generalized solutions. Real work is required to bridge this gap which would complete an important aspect of the critical growth phenomena presented here. This is essentially a problem in linear analysis of the type “weak solutions = strong solutions” as considered by Friedrichs [12], Lax-Phillips [16] and others, and is the subject of ongoing research.

References

- [1] S. Agmon, L. Nirenberg, and M. H. Protter, A maximum principle for a class of hyperbolic equations and applications to equations of mixed elliptic-hyperbolic type, *Comm. Pure Appl. Math.* **6** (1953), 455–470.
- [2] S. A. Aldashev, On the many-dimensional Dirichlet and Tricomi problems for a class of hyperbolic-elliptic equations, *Ukr. Math. J.* **49** (1997), 1783–1790.
- [3] A. K. Aziz and M. Schneider, Frankl-Morawetz problems in R^3 , *SIAM J. Math. Anal.* **10** (1979), 913–921.
- [4] L. Bers, “Mathematical Aspects of Subsonic and Transonic Gas Dynamics”, *Surveys in Applied Mathematics* **3**, John Wiley & Sons, New York, 1958.

- [5] A. V. Bitsadze, Equations of mixed type in three-dimensional regions. (Russian) *Dokl. Akad. Nauk SSSR* **143** (1962), 1017–1019.
- [6] H. Brezis and L. Nirenberg, Positive solutions of nonlinear elliptic equations involving critical Sobolev exponents, *Comm. Pure Appl. Math.* **36** (1983), 437–477.
- [7] D. G. de Figueiredo, J. M. do Ó, and B. Ruf, On an inequality by N. Trudinger and J. Moser and related elliptic equations, *Comm. Pure Appl. Math.* **55** (2002), 135–152.
- [8] D. G. de Figueiredo and E. Mitidieri, A maximum principle for an elliptic system and applications to semilinear problems, *SIAM J. Math. Anal.* **17** (1986), 836–849.
- [9] V. P. Didenko, On the generalized solvability of the Tricomi problem, *Ukrain. Math. J.* **25** (1973), 10–18.
- [10] D. E. Edmunds and N. I. Popivanov, A nonlocal regularization of some overdetermined boundary value problems I, *SIAM J. Math. Anal.* **29** (1998), 85–105.
- [11] F. I. Frankl', On the problems of Chaplygin for mixed sub- and supersonic flows, *Isv. Akad. Nauk. USSR Ser. Mat.* **9** (1945), 121–143.
- [12] K. O. Friedrichs, The identity of weak and strong extensions of differential operators, *Trans. Amer. Math. Soc.* **55** (1944), 132–151.
- [13] P. Garabedian, Partial differential equations with more than two variables in the complex domain, *J. Math. Mech.* **9** (1960), 241–271.
- [14] S. Hawking and R. Penrose, “The nature of space and time”, The Issac Newton Institute Series of Lectures, Princeton University Press, Princeton, NJ, 1996.
- [15] G. D. Karatoprakliev, On the statement and solvability of boundary-value problems for equations of mixed type in multidimensional domains, *Soviet Math. Dokl.* **19** (1978), 304–308.
- [16] P. D. Lax and R. S. Phillips, Local boundary conditions for dissipative symmetric linear differential operators, *Comm. Pure Appl. Math.* **13** (1960), 427–455.
- [17] C. S. Lin, The local isometric embedding in \mathbf{R}^3 of two-dimensional Riemannian manifolds with Gaussian curvature changing sign cleanly, *Comm. Pure Appl. Math.* **39** (1986), 867–887.
- [18] D. Lupo, C. S. Morawetz, and K. R. Payne, On closed boundary value problems for equations of mixed elliptic-hyperbolic type, Preprint **N. 624/P** Politecnico di Milano, 2005.
- [19] D. Lupo and K. R. Payne, A dual variational approach to a class of nonlocal semilinear Tricomi problems, *NoDEA Nonlinear Differential Equations Appl.* **6** (1999), 247–266.
- [20] D. Lupo and K. R. Payne, On the maximum principle for generalized solutions to the Tricomi problem, *Commun. Contemp. Math.* **2** (2000), 535–557.
- [21] D. Lupo and K. R. Payne, Existence of a principal eigenvalue for the Tricomi problem, *Electron. J. Differential Equations Conf.* **05** (2000), 173–180.
- [22] D. Lupo and K. R. Payne, Spectral bounds for Tricomi problems and application to semilinear existence and existence with uniqueness results, *J. Differential Equations* **184** (2002), 139–162.

- [23] D. Lupo and K. R. Payne, Critical exponents for semilinear equations of mixed elliptic-hyperbolic and degenerate types, *Comm. Pure Appl. Math.* **56** (2003), 403–424.
- [24] D. Lupo and K. R. Payne, Conservation laws for equations of mixed elliptic-hyperbolic type, *Duke Math. J.* **127** (2005), 251–290.
- [25] E. Mitidieri and S. I. Pohožaev, Absence of weak solutions for some degenerate and singular hyperbolic problems in \mathbf{R}_+^{n+1} , *Proc. Steklov Inst. Math.* **232** (2001), 240–259.
- [26] E. Mitidieri and S. I. Pohožaev, Apriori estimates and blow-up of solutions to nonlinear partial differential equations and inequalities, *Proc. Steklov Inst. Math.* **234** (2001), 1–362.
- [27] D. Monticelli, Identità di tipo Pohožaev e Risultati di Non Esistenza per Problemi Nonlineari, Tesi di Laurea, Università di Milano, 2002.
- [28] C. S. Morawetz, Note on a maximum principle and a uniqueness theorem for an elliptic-hyperbolic equation, *Proc. Roy. Soc., A* **236** (1956), 141–144.
- [29] C. S. Morawetz, A weak solution for a system of equations of elliptic-hyperbolic type, *Comm. Pure Appl. Math.* **11** (1958), 315–331.
- [30] C. S. Morawetz, Mixed type equations and transonic flow, *J. Hyperbolic Differ. Equ.* **1** (2004), 1–26.
- [31] M. C. Nguyen, On the Grushin equation, *Mat. Zametki* **63** (1998), 95–105; translation in *Math. Notes* **63** (1998), 84–93.
- [32] B. Opic and A. Kufner, “Hardy-type Inequalities”. Pitman Research Notes in Mathematics Series, 219. Longman, Harlow, 1990.
- [33] K. R. Payne, Singular metrics and associated conformal groups underlying differential operators of mixed and degenerate types, *Ann. Mat. Pura Appl.*, to appear.
- [34] S. I. Pohožaev, On the eigenfunctions of the equation $\Delta u + \lambda f(u) = 0$. *Soviet Math. Dokl.* **6** (1965), 1408–1411.
- [35] N. I. Popivanov, The strong solvability of multidimensional analogues of Tricomi and Frankl problems, Mathematics and Mathematical Education, Proc. 8th Spring Conf. Bulgarian Math. Soc., 1979, 472–486 (Russian)
- [36] N. I. Popivanov and M. Schneider, The Darboux problems in \mathbf{R}^3 for a class of degenerated hyperbolic equations, *C. R. Acad. Bulgare Sci.* **41(11)** (1988), 7–9.
- [37] N. I. Popivanov and M. Schneider, Boundary value problems for the nonlinear Tricomi problem in space, *Differential Equations* **27** (1991), 71–85
- [38] N. I. Popivanov and M. Schneider, The Darboux problem in \mathbf{R}^3 for a class of degenerating hyperbolic equations. *J. Math. Anal. Appl.* **175** (1993), 537–579.
- [39] M. H. Protter, New boundary value problems for the wave equation and equations of mixed type, *J. Rat. Mech. Anal.* **3** (1954), 435–446.
- [40] M. Struwe, “Variational Methods”, Springer-Verlag, Berlin, 1990.

Daniela Lupo¹

Dipartimento di Matematica “F. Brioschi”

Politecnico di Milano

Piazza Leonardo da Vinci, 32

20133 Milano

Italy

e-mail: danlup@mate.polimi.it

Kevin R. Payne²

Dipartimento di Matematica “F. Enriques”

Università di Milano

Via Saldini, 50

20133 Milano

Italy

e-mail: payne@mat.unimi.it

Nedyu I. Popivanov³

Department of Mathematics and Informatics

University of Sofia

J. Bourchier Bldg., 5

1164 Sofia

Bulgaria

e-mail: nedyu@fmi.uni-sofia.bg

¹All authors supported in part by MIUR, Project “Metodi Variazionali ed Equazioni Differenziali Non Lineari”.

²Also supported by MIUR, Project “Metodi Variazionali e Topologici nello Studio di Fenomeni Non Lineari”.

³Also supported by Bulgarian NSF Grant VU-MI-02/2005.

On the Shape of Least-Energy Solutions to a Quasilinear Elliptic Equation Involving Critical Sobolev Exponents

Everaldo S. Medeiros

Dedicated to Djairo Guedes de Figueiredo on his 70th birthday

Abstract. In this work we investigate the existence and asymptotic behavior of positive solution to the quasilinear elliptic equation

$$-\Delta_p u + \lambda |u|^{p-2} u = |u|^{p^*-2} u \quad \text{in } \Omega,$$

with homogeneous Neumann condition. Here we show the existence of least-energy solution u_λ for large λ and that the maximum of u_λ concentrates around a point of $\partial\Omega$.

Mathematics Subject Classification (2000). 35B25, 35J60, 35B33, 35B38, 31B25.

Keywords. Elliptic equations, critical exponents, asymptotic behavior, p -Laplacian.

1. Introduction

Let $\Omega \subset \mathbb{R}^N$ ($N \geq 2$) be a smooth bounded domain. Our purpose in this paper is to establish the existence of positive solution and describe the asymptotic behavior to the quasilinear elliptic problem

$$\begin{cases} -\Delta_p u + \lambda |u|^{p-2} u = |u|^{p^*-2} u & \text{in } \Omega, \\ |\nabla u|^{p-2} \frac{\partial u}{\partial \nu} = 0 & \text{on } \partial\Omega, \end{cases} \quad (1.1)$$

where $\Delta_p u := \operatorname{div}(|\nabla u|^{p-2} \nabla u)$ is the p -Laplacian operator, $1 < p < N$, $p^* := Np/(N-p)$, $\lambda > 0$ is a parameter and $\partial/\partial\nu$ is the outer normal derivative.

Research partially supported by PADCT, CAPES and the Millennium Institute for the Global Advancement of Brazilian Mathematics-IM-AGIMB.

In the special case where $p = 2$, the problem (1.1) is also known as the stationary equation of the so called Gierer-Meinhardt system in biological pattern formation (see [9] for more details).

In the last years, problem (1.1) has been extensively studied, amongst others, we can cite the papers due to Ni-Takagi [11], where was studied the case $p = 2$ in the subcritical case and by Wang [15], Adimurthi-Mancini [1] and Adimurthi-Pacella-Yadava [2], for the critical case.

It is a known phenomenon that the solutions of the above equation develop peaks when λ tends to infinity. In [6], del Pino and Flores generalize some similar results for the p-laplacian with nonlinearity with subcritical growth. In this paper we study the critical case, where the existence of solution is more delicate due to the loss of compactness of the Sobolev imbedding.

Our goal here, is to prove the existence and study the asymptotic behavior of nontrivial solution of (1.1). To show the existence, we shall establish a concentration compactness lemma using a similar argument to that given in [10], where the main tools is a Sobolev inequality due to Cherrier [4]. Since $\bar{u} \equiv \lambda^{1/(p^*-p)}$ also is a positive solution of (1.1), we need to establish a upper energy estimate that distinguishes it from those constant solutions for large λ .

Using the minimization argument we obtain the existence of a solution with least energy. To this, we consider $J_\lambda : W^{1,p}(\Omega) \rightarrow \mathbb{R}$, the functional of Euler-Lagrange, associated to the problem (1.1) defined by

$$J_\lambda(u) = \frac{1}{p} \int_{\Omega} (|\nabla u|^p + \lambda|u|^p) dx - \frac{1}{p^*} \int_{\Omega} |u|^{p^*} dx.$$

Our main results in this work are the following.

Theorem 1.1. *There exists $\lambda_0 > 0$ such that for all $\lambda \in (\lambda_0, \infty)$ problem (1.1) admits a positive solution $w_\lambda \in C^{1,\alpha}(\bar{\Omega})$ with*

$$J_\lambda(w_\lambda) < \frac{1}{2N} S^{N/p}. \quad (1.2)$$

In the next result, we shall prove that the maximum point (the peak) will converge to the boundary of Ω . Our strategy will be to use a *blow up* argument.

Theorem 1.2. *Let w_λ be the solution of problem (1.1) obtained in Theorem 1.1 and $x_\lambda \in \bar{\Omega}$ such that $w_\lambda(x_\lambda) = \max_{x \in \bar{\Omega}} w_\lambda(x)$. Then,*

$$\text{dist}(x_\lambda, \partial\Omega) \rightarrow 0, \text{ as } \lambda \rightarrow +\infty.$$

The rest of this paper is organized as follows. In Section 2, we shall establish a concentration compactness lemma using a similar argument to that given in [10] and the proof of some technical lemmata to Section 3. Section 3 is devoted to prove Theorem 1.1. In Section 4, using the blow up argument we shall prove Theorem 1.2. Finally, in Section 5 we shall establish a regularity result.

2. Preliminary results

This section is intended to establish some basic results which will be needed in what follows.

For $\lambda > 0$, denote

$$S_\lambda = \inf_{\mathcal{M}} \left\{ \int_{\Omega} (|\nabla u|^p + \lambda|u|^p) \, dx \right\},$$

where

$$\mathcal{M} = \left\{ u \in W^{1,p}(\Omega) \ : \ \int_{\Omega} |u|^{p^*} \, dx = 1 \right\}.$$

Let S be the best constant of the Sobolev imbedding $D_o^{1,p}(\Omega) \hookrightarrow L^{p^*}(\Omega)$, that is,

$$S = \inf_{D_o^{1,p}(\Omega)} \left\{ \int_{\Omega} |\nabla u|^p \, dx \ ; \ \int_{\Omega} |u|^{p^*} \, dx = 1 \right\},$$

where, $D_o^{1,p}(\Omega)$ is the completion of $C_o^\infty(\Omega)$ with respect to the norm $\|u\| = \left(\int_{\Omega} |\nabla u|^p \, dx \right)^{1/p}$. It is known that S is independent of Ω and depends only of N and is achieved in \mathbb{R}^N by the function

$$u_\epsilon(x) = C_N \epsilon^{(N-p)/p^2} (\epsilon + |x|^{p/(p-1)})^{(p-N)/p},$$

where the constant C_N are chosen in a form that

$$-\Delta_p u_\epsilon = u_\epsilon^{p^*-1} \quad \text{in } \mathbb{R}^N.$$

Proposition 2.1. *For each $\lambda \in (0, \infty)$, we have the estimate*

$$c^* < \frac{1}{2N} S^{N/p}, \tag{2.3}$$

where

$$c^* := \inf_{u \in W^{1,p}(\Omega) \setminus \{0\}} \max_{t \geq 0} J_\lambda(tu).$$

Proof. See Lemma 3.4 in [5] (see also [15, 1] for the case $p=2$). □

Corollary 2.2. *For each $\lambda \in (0, \infty)$ we have*

$$S_\lambda < \frac{S}{2^{p/N}}.$$

In particular, if u_λ is a minimizer of S_λ , then $w_\lambda = S_\lambda^{1/(p^-p)} u_\lambda$ is a solution of (1.1).*

Proof. First, observe that

$$S_\lambda = \inf \left\{ Q_\lambda(u); \quad u \in W^{1,p}(\Omega) \setminus \{0\} \right\},$$

where

$$Q_\lambda(u) := \frac{\int_{\Omega} (|\nabla u|^p + \lambda|u|^p)}{(\int_{\Omega} |u|^{p^*})^{p/p^*}} \quad u \neq 0.$$

Thus,

$$\max_{t \geq 0} J_\lambda(tu) = \frac{1}{N} \left(\frac{\int_\Omega (|\nabla u|^p + \lambda|u|^p)}{(\int_\Omega |u|^{p^*})^{p/p^*}} \right)^{N/p} \geq 1/N S_\lambda^{N/p}; \quad u \neq 0.$$

Consequently,

$$\frac{1}{N} S_\lambda^{N/p} \leq c^*. \tag{2.4}$$

Thus, the proof follows from Proposition 2.1. □

In the next result, we go on to establish a relation between S and functions in $W^{1,p}(\Omega)$.

Lemma 2.3. *Given $\delta > 0$, there exist $c(\delta) > 0$ such that for each $u \in W^{1,p}(\Omega)$*

$$\|u\|_{L^{p^*}(\Omega)}^p \leq \left(\frac{2^{p/N}}{S} + \delta\right) \|\nabla u\|_{L^p(\Omega)}^p + c(\delta) \|u\|_{L^p(\Omega)}^p. \tag{2.5}$$

This lemma is due to Cherrier [4]. The proof of this inequality follows by similar argument of [3].

Using this inequality, we shall prove a concentration compactness lemma. This result will be a fundamental step in the proof of the existence of a minimizer for S_λ .

Lemma 2.4 (Concentration-Compactness). *Let (u_n) be a sequence in $W^{1,p}(\Omega)$ converging weakly to some u and suppose that for some subsequence there exists two bounded non-negative measures μ, ν in Ω such that $|u_n|^{p^*}$ and $|\nabla u_n|^p$ converge weakly in the sense of measure to ν and μ , respectively. Then, there exists an at most numerable set $J, (x_j)_{j \in J} \in \bar{\Omega}$ and real numbers $\mu_j > 0, \nu_j > 0$ such that:*

$$\begin{cases} |u_k|^{p^*} \rightharpoonup \nu = |u|^{p^*} + \sum_{j \in J} \nu_j \delta_{x_j}, \\ |\nabla u_k|^p \rightharpoonup \mu \geq |\nabla u|^p + \sum_{j \in J} \mu_j \delta_{x_j}. \end{cases} \tag{2.6}$$

Moreover, if $x_j \in \Omega$,

$$S \nu_j^{p/p^*} \leq \mu_j,$$

and if $x_j \in \partial\Omega$,

$$\frac{S}{2^{p/n}} \nu_j^{p/p^*} \leq \mu_j.$$

Therefore,

$$\frac{S}{2^{p/n}} \nu_j^{p/p^*} \leq \mu_j.$$

Proof. The representation of the measures follows from the Sobolev inequality

$$\|u\|_{L^{p^*}(\Omega)} \leq C \|u\|_{W^{1,p}(\Omega)}$$

and Lemma 1.2 in Lions [10]. Since $x_i \in \bar{\Omega}$ we assume two cases:

Case 1: If $x_i \in \text{int}(\Omega)$, consider $\delta > 0$ such that $B(x_i, \delta) \subset \Omega$ and $\varphi \in C^\infty(\Omega)$ with $\text{supp } \varphi \subset B(x_i, \delta)$. By Sobolev imbedding

$$\begin{aligned} S^{1/p} \left(\int_{B(x_i, \delta)} |\varphi|^{p^*} |u_n|^{p^*} \right)^{1/p^*} &\leq \left(\int_{B(x_i, \delta)} |\nabla(\varphi u_n)|^p \right)^{1/p} \\ &\leq \left(\int_{B(x_i, \delta)} |\nabla \varphi|^p |u_n|^p \right)^{1/p} + \left(\int_{B(x_i, \delta)} |\varphi|^p |\nabla u_n|^p \right)^{1/p}. \end{aligned}$$

Taking the limit in n in the inequality above and using that $|u_n|^{p^*} \rightharpoonup d\nu$ and $|\nabla u_n|^p \rightharpoonup d\mu$ in the sense of measure, we obtain

$$S^{1/p} \left(\int_{B(x_i, \delta)} |\varphi|^{p^*} d\nu \right)^{1/p^*} \leq \left(\int_{B(x_i, \delta)} |\varphi|^p d\mu \right)^{1/p} + \left(\int_{B(x_i, \delta)} |\nabla \varphi|^p |u|^p \right)^{1/p}. \tag{2.7}$$

In particular, choosing $\varphi_\epsilon := \varphi(\frac{x-x_i}{\epsilon})$ in (2.7), where $\varphi \in C_0^\infty(\Omega)$ and $0 \leq \varphi \leq 1$, we get

$$\varphi(x) = \begin{cases} 1 & \text{if } |x - x_i| < \frac{\delta}{2}, \\ 0 & \text{if } |x - x_i| \geq \delta, \end{cases}$$

and taking $\epsilon \rightarrow 0$, we have

$$S^{1/p} \left(\int_{\{x_i\}} d\nu \right)^{1/p^*} \leq \left(\int_{\{x_i\}} d\mu \right)^{1/p},$$

because $\varphi_\epsilon \rightarrow \chi_{\{x_i\}}$ a.e. in Ω , where $\chi_{\{x_i\}}$ is the characteristic function of the set $\{x_i\}$. Consequently, $S\nu_j^{\frac{p}{p^*}} \leq \mu_j$.

Case 2: If $x_i \in \partial\Omega$, by Lemma 2.3, given $\delta > 0$ there exist $c(\delta)$ such that

$$\left(\int_{\Omega} |u_n|^{p^*} |\varphi|^{p^*} \right)^{1/p^*} \leq \left(\frac{2^{1/N}}{S} + \delta \right)^{1/p} \left(\int_{\Omega} |\nabla u_n \varphi|^p \right)^{1/p} + (c(\delta) \int_{\Omega} |\varphi|^p |u_n|^p)^{1/p}.$$

First we assume that $u_n \rightarrow 0$. Taking the limit in the inequality above we obtain

$$\left(\int_{\Omega} |\varphi|^{p^*} d\nu \right)^{1/p^*} \leq \left(\frac{2^{1/N}}{S} + \delta \right)^{1/p} \left(\int_{\Omega} |\varphi|^p \right)^{1/p}.$$

Taking, $\delta \rightarrow 0$ and using the same idea as in the previous case we obtain

$$\mu_i \geq \frac{S}{2^{p/N}} \nu_i^{p/p^*}.$$

The case $u \not\equiv 0$, follows considering the sequence (v_k) given by $v_k := u_k - u$ and the Brezis-Lieb lemma [16]. □

3. Existence of a positive solution

The goal of this section is the proof of Theorem 1.1. For this, we first establish some preliminary results.

Proposition 3.1. *For each $\lambda \in (0, +\infty)$, S_λ is attained.*

Proof. If $\lambda > 0$, by Corollary 2.2 we have

$$0 < S_\lambda < \frac{S}{2^{p/N}}. \tag{3.8}$$

Now, if (u_n) is a minimizing sequence for S_λ , that is,

$$S_\lambda + o_n(1) = \int_\Omega (|\nabla u_n|^p + \lambda|u_n|^p), \quad \|u_n\|_{p^*} = 1, \tag{3.9}$$

we have (u_n) is bounded in $W^{1,p}(\Omega)$. Since, $W^{1,p}(\Omega)$ is a reflexive space, by Sobolev imbedding we have

$$\begin{aligned} u_n &\rightharpoonup u && \text{in } W^{1,p}(\Omega), \\ u_n &\rightarrow u && \text{in } L^p(\Omega). \end{aligned}$$

Now we shall use Lemma 2.3 to show that $u \not\equiv 0$. Indeed, suppose that $u \equiv 0$. If (3.8) holds, we can choose $\delta > 0$ such that

$$\left(\frac{2^{p/N}}{S} + \delta\right)S_\lambda \leq a < 1. \tag{3.10}$$

It follows from Lemma 2.3 that

$$1 \leq \left(\frac{2^{p/N}}{S} + \delta\right)\left(S_\lambda + o_n(1) - \lambda \int_\Omega |u_n|^p\right) + C(\delta)\|u_n\|_p^p.$$

Since $\|u_n\|_p \rightarrow 0$, we have

$$1 \leq \left(\frac{2^{p/N}}{S} + \delta\right)S_\lambda \leq a < 1,$$

which is impossible. Thus, $u \not\equiv 0$ and

$$\int_\Omega |u|^{p^*} = \alpha \in (0, 1].$$

Suppose that $\alpha < 1$. Since $\|u_n\|_{p^*} = 1$, if ν is the weak limit of $|u_n|^{p^*}$, as in Lemma 2.4 we have

$$1 = \int_\Omega d\nu = \int_\Omega |u|^{p^*} + \sum_{j \in J} \nu_j = \alpha + \sum_{j \in J} \nu_j.$$

Thus,

$$\sum_{j \in J} \nu_j = 1 - \alpha > 0.$$

Moreover, using the fact that

$$\lim_{n \rightarrow \infty} \int_\Omega |\nabla u_n|^p + \lambda \int_\Omega |u_n|^p = S_\lambda,$$

and denoting by μ the weak limit of $|\nabla u_n|^p$, by Lemma 2.4 we obtain

$$\int_\Omega d\mu + \lambda \int_\Omega |u|^p = S_\lambda \geq \int_\Omega |\nabla u|^p + \sum_{j \in J} \mu_j + \lambda \int_\Omega |u|^p.$$

Thus,

$$\int_{\Omega} (|\nabla u|^p + \lambda|u|^p) \leq S_{\lambda} - \sum_{j \in J} \mu_j. \tag{3.11}$$

It follows from Lemma 2.4 and (3.8) that

$$\sum_{j \in J} \mu_j \geq \frac{S}{2^{p/N}} \sum_{j \in J} (\nu_j)^{p/p^*} > S_{\lambda} \sum_{j \in J} (\nu_j)^{p/p^*}.$$

This together with (3.11) implies that

$$\int_{\Omega} (|\nabla u|^p + \lambda|u|^p) < S_{\lambda} \left(1 - \sum_{j \in J} (\nu_j)^{p/p^*}\right).$$

Now, notice that

$$1 = \left(1 - \sum_{j \in J} \nu_j + \sum_{j \in J} \nu_j\right)^{p/p^*} \leq \left(1 - \sum_{j \in J} \nu_j\right)^{p/p^*} + \sum_{j \in J} (\nu_j)^{p/p^*}.$$

Therefore,

$$\int_{\Omega} (|\nabla u|^p + \lambda|u|^p) < S_{\lambda} \left(1 - \sum_{j \in J} \nu_j\right)^{p/p^*} = S_{\lambda} \alpha^{p/p^*}. \tag{3.12}$$

On other hand, by definition of S_{λ}

$$\int_{\Omega} (|\nabla u|^p + \lambda|u|^p) \geq S_{\lambda} \left(\int_{\Omega} |u|^{p^*}\right)^{p/p^*} = S_{\lambda} \alpha^{p/p^*}. \tag{3.13}$$

From (3.12)–(3.13) we obtain

$$S_{\lambda} \alpha^{p/p^*} \leq \int_{\Omega} (|\nabla u|^p + \lambda|u|^p) < S_{\lambda} \alpha^{p/p^*},$$

that is a contradiction. Thus, $\|u\|_{p^*} = 1$. Consequently,

$$S_{\lambda} \leq \int_{\Omega} (|\nabla u|^p + \lambda|u|^p).$$

By semicontinuity of norm, we obtain

$$\int_{\Omega} (|\nabla u|^p + \lambda|u|^p) \leq \lim_{n \rightarrow \infty} \int_{\Omega} (|\nabla u_n|^p + \lambda|u_n|^p) = S_{\lambda}.$$

Therefore,

$$S_{\lambda} = \int_{\Omega} (|\nabla u|^p + \lambda|u|^p), \quad \text{with } \|u\|_{p^*} = 1.$$

This proves the Proposition. □

As consequence of the Proposition 3.1, S_{λ} has the following proprieties.

Proposition 3.2. *The function S_λ is continuous, concave and nondecreasing for all $\lambda \in (0, \infty)$. Moreover,*

$$\lim_{\lambda \rightarrow 0} S_\lambda = 0 \quad \text{and} \quad \lim_{\lambda \rightarrow \infty} S_\lambda = \frac{S}{2^{p/n}}.$$

Proof. Taking $\varphi = c$ as a test function we get $S_\lambda \rightarrow 0$ as $\lambda \rightarrow 0$. Now, notice that

$$\begin{aligned} (1-t) \int_{\Omega} (|\nabla u|^p + \lambda_1 |u|^p) &+ t \left(\int_{\Omega} |\nabla u|^p + \lambda_2 |u|^p \right) \\ &= \int_{\Omega} |\nabla u|^p + \left((1-t)\lambda_1 + t\lambda_2 \right) \int_{\Omega} |u|^p. \end{aligned}$$

Thus, $(1-t)S_{\lambda_1} + tS_{\lambda_2} \leq S_{(1-t)\lambda_1 + t\lambda_2}$. Therefore, S_λ is a concave function. Moreover, S_λ is nondecreasing. In particular, S_λ is continuous with respect to λ . By Proposition 3.1 and Corollary 2.2, if $\lambda_n \rightarrow \infty$ there exist $(u_n) \subset W^{1,p}(\Omega)$ such that

$$Q_{\lambda_n}(u_n) = S_{\lambda_n} < \frac{S}{2^{p/N}}.$$

Denote by $S_\infty := \lim_{n \rightarrow \infty} S_{\lambda_n}$ and suppose that $S_\infty < \frac{S}{2^{p/N}}$. Let $\delta > 0$ be such that

$$S_\infty \left(\frac{2^{p/N}}{S} + \delta \right) = a < 1.$$

By Lemma 2.3,

$$\begin{aligned} \|\nabla u_n\|_{L^p(\Omega)}^p + \lambda_n \|u_n\|_{L^p(\Omega)}^p &= S_\lambda \|u_n\|_{L^{p^*}(\Omega)}^p \\ &\leq S_\infty \left(\frac{2^{p/N}}{S} + \delta \right) \|\nabla u_n\|_{L^p(\Omega)}^p + S_\infty c(\delta) \|u_n\|_{L^p(\Omega)}^p \\ &\leq a \|\nabla u_n\|_{L^p(\Omega)}^p + S_\infty c(\delta) \|u_n\|_{L^p(\Omega)}^p, \end{aligned}$$

that is,

$$(1-a) \|\nabla u_n\|_{L^p(\Omega)}^p + (\lambda_n - S_\infty c(\delta)) \|u_n\|_{L^p(\Omega)}^p \leq 0 \quad \text{with } u_n \neq 0,$$

which is impossible. Therefore, $\lim_{\lambda \rightarrow \infty} S_\lambda = \frac{S}{2^{p/N}}$ and the proof is thus concluded. □

Proof of Theorem 1.1. Let u_λ be a minimizer of S_λ given in Proposition 3.1. By the Lagrange multiplier theorem, we have

$$\int_{\Omega} |\nabla u_\lambda|^{p-2} \nabla u_\lambda \nabla \varphi + \lambda \int_{\Omega} |u|^{p-2} u \varphi = S_\lambda \int_{\Omega} |u|^{p^*-2} u \varphi, \tag{3.14}$$

for all $\varphi \in W^{1,p}(\Omega)$. After a variable change, we obtain that $w_\lambda = S_\lambda^{1/(p^*-p)} u_\lambda$ is a solution of (1.1). Moreover,

$$J_\lambda(w_\lambda) = \frac{1}{n} S_\lambda^{n/p} < \frac{1}{2n} S^{n/p}.$$

On the other hand, if $\bar{u}_\lambda \equiv \lambda^{1/(p^*-p)}$ we get

$$J_\lambda(\lambda^{1/(p^*-p)}) = \frac{\lambda}{p} \int_{\Omega} \lambda^{p/(p^*-p)} - \frac{1}{p^*} \int_{\Omega} \lambda^{p^*/(p^*-p)} = \frac{1}{N} \lambda^{N/p} |\Omega|.$$

Choosing,

$$\lambda \geq \frac{S}{(2|\Omega|)^{p/N}},$$

we obtain a nontrivial solution. Moreover, notice that $|u_\lambda|$ also is a minimizer of S_λ . Thus, we can assume $w_\lambda \geq 0$. Consequently,

$$-\Delta_p w_\lambda + \lambda w_\lambda^{p^*-1} = w_\lambda^{p^*-1} \geq 0.$$

Consequently,

$$\Delta_p w_\lambda \leq \lambda w_\lambda^{p-1}.$$

By the regularity result (see Theorem 2 in Lieberman [8]) we have that $u_\lambda \in C^{1,\alpha}(\bar{\Omega})$. Now, notice that the function $g(s) = \lambda s^{p-1}$ is nondecreasing, $g(0) = 0$ and

$$\int_0^1 (g(s)s)^{-1/p} = \infty.$$

Thus, Theorem 5 in Vasquez [14] yields that $u_\lambda > 0$. This completes the proof of Theorem 1.1. □

4. Asymptotic behavior

In this section, we will use a *blow up* argument to study the asymptotic behavior of positive solutions of problem (1.1). More precisely, we will prove Theorem 1.2. The key steps in the proof of this result are:

Lemma 4.1. *Let u_λ be a nontrivial positive solution of problem (1.1) and $M_\lambda := \max_\Omega u_\lambda(x)$. Then, $M_\lambda \rightarrow +\infty$ when $\lambda \rightarrow \infty$.*

Proof. Since u_λ is a solution of problem (1.1), we have

$$\int_\Omega |\nabla u_\lambda|^{p-2} \nabla u_\lambda \nabla \varphi + \lambda \int_\Omega u_\lambda^{p-1} \varphi = \int_\Omega u_\lambda^{p^*-1} \varphi, \quad \varphi \in W^{1,p}(\Omega). \tag{4.15}$$

In particular, if $\varphi \equiv 1$ we obtain

$$\int_\Omega (\lambda u_\lambda^{p-1} - u_\lambda^{p^*-1}) = 0.$$

Thus, if $u_\lambda \not\equiv \bar{u} = \lambda^{1/(p^*-p)}$ there exists $x_o \in \Omega$ such that

$$\lambda u_\lambda^{p-1}(x_o) - u_\lambda^{p^*-1}(x_o) < 0,$$

that is,

$$\lambda^{1/(p^*-p)} < u_\lambda(x_o) \leq \max_{x \in \Omega} u_\lambda(x) = M_\lambda. \tag{4.16}$$

Therefore, $\lim_{\lambda \rightarrow \infty} M_\lambda = +\infty$. □

The next lemma is also crucial in the proof of Theorem 1.2.

Lemma 4.2. *Let $u_\lambda \in W^{1,p}(\Omega)$ such that $Q_\lambda(u_\lambda) \leq \frac{S}{2^{p/N}}$ and*

$$0 < \lim_{\lambda \rightarrow \infty} \|u_\lambda\|_{p^*} \leq \overline{\lim}_{\lambda \rightarrow \infty} \|u_\lambda\|_{p^*} < \infty, \tag{4.17}$$

then

$$\lim_{\lambda \rightarrow \infty} \lambda \|u_\lambda\|_p^p = 0.$$

In particular, if u_λ is a least energy solution, we have

$$\lim_{\lambda \rightarrow \infty} \int_\Omega |\nabla u_\lambda|^p = \frac{S^{N/p}}{2}.$$

Proof. Let (λ_n) be a sequence such that $\lambda_n \rightarrow \infty$. By the above hypotheses, (u_{λ_n}) is bounded in $W^{1,p}(\Omega)$. Thus, there exist $u \in W^{1,p}(\Omega)$ such that

$$\begin{aligned} u_{\lambda_n} &\rightharpoonup u, && \text{in } W^{1,p}(\Omega), \\ u_{\lambda_n} &\rightarrow u, && \text{in } L^p(\Omega). \end{aligned}$$

This, together with (4.17) implies that $(\lambda_n \|u_{\lambda_n}\|_p^p)$ is bounded. Consequently, $u \equiv 0$. By Lemma 2.3, we have

$$1 \leq \left(\frac{2^{p/N}}{S} + \delta\right) \frac{\|\nabla u_{\lambda_n}\|_p^p}{\|u_{\lambda_n}\|_{p^*}^p} + C(\delta) \frac{\|u_{\lambda_n}\|_p^p}{\|u_{\lambda_n}\|_{p^*}^p}.$$

Thus,

$$\frac{S}{2^{p/N}} \leq \lim_{\lambda_n \rightarrow \infty} \frac{\|\nabla u_{\lambda_n}\|_p^p}{\|u_{\lambda_n}\|_{p^*}^p} \leq \lim_{\lambda_n \rightarrow \infty} Q_{\lambda_n}(u_{\lambda_n}) \leq \frac{S}{2^{p/N}},$$

that is,

$$\lim_{\lambda_n \rightarrow \infty} \frac{\|\nabla u_{\lambda_n}\|_p^p}{\|u_{\lambda_n}\|_{p^*}^p} = \frac{S}{2^{p/N}} = \lim_{\lambda_n \rightarrow \infty} Q_{\lambda_n}(u_{\lambda_n}).$$

Therefore,

$$\lim_{\lambda_n \rightarrow \infty} \lambda_n |u_{\lambda_n}|_p^p = 0.$$

If u_λ is a least energy solution, we get

$$S_{\lambda_n}^{N/p} = \int_\Omega |\nabla u_{\lambda_n}|^p + \lambda_n |u_{\lambda_n}|^p.$$

This, together with Proposition 3.2, implies

$$\frac{S^{p/N}}{2} = \lim_{\lambda_n \rightarrow \infty} S_{\lambda_n}^{N/p} = \lim_{\lambda_n \rightarrow \infty} \int_\Omega (|\nabla u_{\lambda_n}|^p + \lambda_n |u_{\lambda_n}|^p) = \lim_{\lambda_n \rightarrow \infty} \int_\Omega |\nabla u_{\lambda_n}|^p.$$

Therefore,

$$\lim_{\lambda_n \rightarrow \infty} \int_\Omega |\nabla u_{\lambda_n}|^p = \frac{S^{p/N}}{2}.$$

This finishes the proof. □

Proof of Theorem 1.2. Let (x_λ) in $\bar{\Omega}$ such that

$$\max_{x \in \bar{\Omega}} u_\lambda(x) = u_\lambda(x_\lambda).$$

Since $\bar{\Omega}$ is bounded, there exists a subsequence (x_{λ_n}) and $x_o \in \bar{\Omega}$, such that $x_{\lambda_n} \rightarrow x_o$. We claim that $x_o \in \partial\Omega$. Indeed, suppose that $x_o \in \text{int}(\Omega)$. Then, $\text{dist}(x_{\lambda_n}, \partial\Omega) \geq \alpha > 0$ for some α and n large. This together with Lemma 4.1 implies

$$\lim_{n \rightarrow \infty} \text{dist}(x_{\lambda_n}, \partial\Omega) M_{\lambda_n}^{N/p} = \infty.$$

From (4.16) we have that the sequence (ϵ_n) defined by:

$$\lambda_n \epsilon_n^p := \frac{\lambda_n}{M_{\lambda_n}^{p^* - p}},$$

is bounded. Thus, we can assume $\lambda_n \epsilon_n^p \rightarrow a \geq 0$. Defining,

$$v_{\lambda_n}(x) := \epsilon_n^{(N-p)/p} u_{\lambda_n}(\epsilon_n^{p/(p-1)} x + x_{\lambda_n}) \text{ in } \Omega_{\lambda_n},$$

where $\Omega_{\lambda_n} := (\Omega - \{x_{\lambda_n}\})/\epsilon_n$, we obtain

$$-\Delta_p v_{\lambda_n} + \lambda_n \epsilon_n^p v_{\lambda_n}^{p-1} = v_{\lambda_n}^{p^* - 1} \text{ in } \Omega_{\lambda_n}, \tag{4.18}$$

$$\frac{\partial v_{\lambda_n}}{\partial \eta} = 0 \text{ on } \partial\Omega_{\lambda_n},$$

and

$$v_{\lambda_n}(0) = 1, \quad 0 < v_{\lambda_n}(x) \leq 1 \text{ in } \Omega_{\lambda_n}.$$

By Lemma 5.2 below and regularity results in Lieberman [8], $v_{\lambda_n} \in C_{loc}^{1,\alpha}(\Omega_{\lambda_n})$. Since

$$\lim_{n \rightarrow \infty} \frac{\text{dist}(\partial\Omega, x_{\lambda_n})}{\epsilon_n} = \infty,$$

for each $R > 0$ there exists $n_o \in \mathbb{N}$ such that $B_R(x_o) \subset \Omega_{\lambda_n}$ for $n \geq n_o$. Thus, $\Omega_{\lambda_n} \rightarrow \mathbb{R}^N$. By Theorem 1 in [13]

$$\|v_{\lambda_n}\|_{C^{1,\alpha}(B_R)} \leq K, \quad n \geq n_o. \tag{4.19}$$

On the other hand, by the Ascoli-Arzelà Theorem and (4.19) there exists $w \in C^1(\bar{\Omega})$ and a subsequence v_{λ_n} such that $v_{\lambda_n} \rightarrow w$ in $C^1(\bar{B}_R)$. Taking limit in (4.18), we obtain

$$\int_{B_R} |\nabla w|^{p-2} \nabla w \nabla \varphi + \int_{B_R} w^{p-1} w \varphi + \int_{B_R} w^{p^* - 1} w \varphi, \quad \varphi \in C_c^\infty(B_R).$$

Moreover, observing that

$$0 \leq w \leq 1, \quad w(0) = 1,$$

by the Maximum Principle in Vasquez [14], $w > 0$. Using a diagonal argument, we can see

$$-\Delta_p w + a w^{p-1} = w^{p^* - 1} \text{ in } \mathbb{R}^N.$$

Then, by Pohozaev variational identity (see Pucci and Serrin [12]), $a = 0$. Therefore,

$$\int_{\mathbb{R}^N} |\nabla w|^p = \int_{\mathbb{R}^N} w^{p^*}. \tag{4.20}$$

By Fatou Lemma, we have

$$\begin{aligned} \int_{\mathbb{R}^N} |\nabla w|^p &\leq \liminf_{n \rightarrow \infty} \int_{\Omega_{\lambda_n}} |\nabla v_{\lambda_n}|^p = \liminf_{n \rightarrow \infty} \int_{\Omega} |\nabla u_{\lambda_n}|^p < \infty, \\ \int_{\mathbb{R}^N} |w|^{p^*} &\leq \liminf_{n \rightarrow \infty} \int_{\Omega_n} |v_{\lambda_n}|^{p^*} = \liminf_{n \rightarrow \infty} \int_{\Omega} |u_{\lambda_n}|^{p^*} < \infty. \end{aligned}$$

From (4.20) and Lemma 4.2, we get

$$S^{N/p} \leq \int_{\mathbb{R}^N} |\nabla w|^p \leq \liminf_{n \rightarrow \infty} \int_{\Omega} |\nabla u_{\lambda_n}|^p = \frac{S^{N/p}}{2},$$

which is a contradiction. This completes the proof of Theorem 1.2. □

5. Regularity of solutions

In this section, our goal is to prove the regularity of the weak solution of problem (1.1). To this, by a regularity result due to Lieberman [8], it is sufficient to show a estimate L^∞ . Since $u \in W^{1,p}(\Omega)$, let us start with the following result.

Lemma 5.1. *We will denote by $\bar{B} = B_1 \cap \{x_n > h(x')\}$, where B_1 is the unitary ball in \mathbb{R}^N , $h(x')$ is a function defined in the set $\{x' \in \mathbb{R}^N; |x'| < 1\}$ with $h(0) = 0$ and $\nabla h(0) = 0$. Then, for $u \in H^1(B_1)$ with $\text{supp}(u) \subset B_1$, we have:*

(1) *If $h \equiv 0$,*

$$\int_{\bar{B}} |\nabla u|^p \geq 2^{-p/n} S \left(\int_{\bar{B}} |u|^{p^*} dx \right)^{p/p^*}. \tag{5.21}$$

(2) *For any $\epsilon > 0$, there exists $\delta > 0$ dependent only on ϵ , such that if $|\nabla h| \leq \delta$, then*

$$\int_{\bar{B}} |\nabla u|^p \geq (2^{-p/n} S - \epsilon) \left(\int_{\bar{B}} |u|^{p+1} dx \right)^{p/p^*}. \tag{5.22}$$

Proof. Let \tilde{u} be defined by $\tilde{u}(x', x_n) := u(x', -x_n)$ if $x_n < 0$. Now, notice that

$$\begin{aligned} \int_{\bar{B}} |\nabla u|^p &= \frac{1}{2} \int_{\bar{B}_1} |\nabla \tilde{u}| dx \\ &\geq \frac{1}{2} S \left(\int_{\bar{B}_1} |\tilde{u}|^{p^*} dx \right)^{p/p^*} \\ &= 2^{-p/n} S \left(\int_{\bar{B}} |u|^{p^*} dx \right)^{p/p^*}. \end{aligned}$$

Taking the coordinate transformation $y' = x', y_n = x_n - h(x')$, (5.22) follows immediately from (5.21) □

Lemma 5.2. *Let $u \in W^{1,p}(\Omega)$ be a nonnegative weak solution of problem*

$$\begin{cases} -\Delta_p u = a(x)u^{p-1} & \text{in } \Omega, \\ \frac{\partial u}{\partial \eta} = 0 & \text{on } \partial\Omega, \end{cases} \tag{5.23}$$

with $a \in L^{n/p}(\Omega)$. Then $u \in L^\infty(\Omega)$.

Proof. Fixed $\beta > 1$ and $k > 0$, define $G_k \in C^1([0, +\infty), \mathbb{R})$ by: $G_k(t) = t^\beta$ for $0 \leq t \leq k$ and $G_k(t) = k^{\beta-1}t$ for $t > k$. If u is a solution of (5.23) then, $G_k(u), G'_k(u)$ and $F_k(u) = \int_0^u |G_k(s)|^p ds$ belong to $W^{1,p}(\Omega)$. Now, we can see that G_k and F_k have the following properties:

- (i) $F_k(u) \leq uF'_k(u) = u|G_k(u)|^p$,
- (ii) $u^{p-1}F_k(u) \leq C_1G_k^p(u)$, where C_1 is independent of k ,
- (iii) $G'_k(u)u \leq \beta G_k(u)$.

Taking $v = F_k(u)\eta^p$ as test function in

$$\int_{\Omega} |\nabla u|^{p-2} \nabla u \nabla v = \int_{\Omega} a(x)u^{p-1}v,$$

where η will be chosen later, we have

$$\int_{\Omega} |\nabla u|^p |G'_k(u)|^p \eta^p \leq p \int_{\Omega} |\nabla u|^{p-1} \eta^{p-1} |\nabla \eta| F_k(u) + \int_{\Omega} |a(x)|(u^{p-1}F_k(u))\eta^p.$$

This together with (ii) implies

$$\int_{\Omega} |\nabla u|^p |G'_k(u)|^p \eta^p \leq p \int_{\Omega} |\nabla u|^{p-1} \eta^{p-1} |\nabla \eta| F_k(u) + C_1 \int_{\Omega} |a(x)|G_k^p(u)\eta^p. \tag{5.24}$$

Using the Young's inequality, (i) and (iii) we obtain

$$\begin{aligned} \int_{\Omega} |\nabla u|^{p-1} \eta^{p-1} |\nabla \eta| F_k(u) &\leq \int_{\Omega} |\nabla u|^{p-1} \eta^{p-1} |\nabla \eta| (u|G'_k(u)|^p) \\ &\leq \int_{\Omega} \left(\epsilon |\nabla u|^p \eta^p + c(\epsilon) |\nabla \eta|^p u^p \right) |G'_k(u)|^p \\ &= \epsilon \int_{\Omega} |\nabla u|^p |G'_k(u)|^p \eta^p + c(\epsilon) \int_{\Omega} |\nabla \eta|^p u^p |G'_k(u)|^p \\ &\leq \epsilon \int_{\Omega} |\nabla u|^p |G'_k(u)|^p \eta^p + c(\epsilon) \beta^p \int_{\Omega} |\nabla \eta|^p |G_k(u)|^p. \end{aligned} \tag{5.25}$$

From (5.24)–(5.25) we get

$$\int_{\Omega} |\nabla u|^p |G'_k(u)|^p \eta^p \leq C_2 \beta^p \int_{\Omega} |\nabla \eta|^p G_k^p(u) + C_3 \int_{\Omega} |a(x)|(G_k(u)\eta)^p. \tag{5.26}$$

Now, notice that

$$\begin{aligned} \int_{\Omega} |\nabla(G_k(u)\eta)|^p &= \int_{\Omega} |G'_k(u)\nabla(u\eta) + G_k(u)\nabla\eta|^p \\ &\leq C \int_{\Omega} |\nabla u|^p |G'_k(u)|^p \eta^p + C \int_{\Omega} |\nabla \eta|^p G_k^p(u). \end{aligned} \tag{5.27}$$

Thus, from (5.26)–(5.27) we have

$$\int_{\Omega} |\nabla(G_k(u)\eta)|^p \leq C_3\beta^p \int_{\Omega} |\nabla\eta|^p G_k^p(u) + C_4 \int_{\Omega} |a(x)|(G_k(u)\eta)^p. \tag{5.28}$$

Fix $x_o \in \bar{\Omega}$, let $\eta \geq 0$ be a smooth function with $\text{supp } \eta \subset B(x_o, \delta)$ and $\eta(x) = 1$ for $x \in B(x_o, \frac{\delta}{2})$ where δ sufficiently small. By Lemma 5.1, we obtain

$$\int_{\Omega} |\nabla v|^p > \frac{1}{2^p} S \left[\int_{\Omega} |v|^{p^*} \right]^{p/p^*}, \tag{5.29}$$

for all $v \in W^{1,p}(\Omega)$ with $\text{supp } v \subset B(x_o, \delta) \cap \bar{\Omega}$. Since $a \in L^{n/p}(\Omega)$, we can choose δ sufficiently small such that

$$\|a\|_{L^{n/p}(B(x_o, \delta))} \leq \frac{S}{2^{p+1}C_4}.$$

Using Hölder’s inequality and (5.29) we have

$$\begin{aligned} \int_{\Omega} |a(x)|^p G_k^p(u)\eta^p &\leq \|a\|_{L^{n/p}(B(x_o, \delta))} \|G_k(u)\eta\|_{p^*}^p \\ &\leq \frac{1}{2C_4} \|\nabla(G_k(u)\eta)\|_p^p. \end{aligned} \tag{5.30}$$

This together with (5.28)–(5.30) implies

$$\int_{\Omega} |\nabla u|^p |G'_k(u)|^p \eta^p \leq C_3\beta^p \int_{\Omega} |\nabla\eta|^p G_k^p(u) + \frac{1}{2} \int_{\Omega} |\nabla(G_k(u)\eta)|^p, \tag{5.31}$$

that is

$$\int_{\Omega} |\nabla(G_k(u)\eta)|^p \leq C\beta^p \int_{\Omega} |\nabla\eta|^p G_k^p(u), \tag{5.32}$$

where C is independent of δ and k . We get from (5.29)–(5.32) that

$$\left(\int_{\Omega} (G_k(u)\eta)^{p^*} \right)^{p/p^*} \leq C\beta^p \int_{\Omega} |\nabla\eta|^p G_k^p(u). \tag{5.33}$$

Taking $k \rightarrow \infty$ in (5.33) we have

$$\left(\int_{\Omega} u^{\beta p^*} \eta^{p^*} \right)^{p/p^*} \leq C\beta^p \int_{\Omega} |\nabla\eta|^p u^{\beta p}, \tag{5.34}$$

because $\beta > 1$. Since $x_o \in \bar{\Omega}$ arbitrary, we have

$$\left(\int_{\Omega} u^{\beta p^*} \right)^{p/p^*} \leq C\beta^p \int_{\Omega} u^{\beta p}, \text{ for } \beta > 1. \tag{5.35}$$

Now, define the sequence $\beta_i = (p^*/p)^i$ for $i \geq 1$ and observe that (β_i) is a increasing sequence and $\beta_i \rightarrow \infty$ as $i \rightarrow \infty$. Using induction we can see that

$$\int_{\Omega} |u|^{\beta_i p^*} \leq MC^{(\beta_1 + \dots + \beta_i)} (\beta_1^p)^{\beta_i} (\beta_2^p)^{\beta_{i-1}} \dots (\beta_{i-1}^p)^{\beta_2} (\beta_i^p)^{\beta_1},$$

where $M = \|u\|_{p^*}^{\beta^*}$. Therefore,

$$\begin{aligned} \|u\|_{L^{\beta_i p^*}(\Omega)} &\leq M^{1/p^*} C^{(\beta_1 + \dots + \beta_i)/\beta_i p^*}(\beta_1) \frac{p(i\beta_1 + (i-1)\beta_1^2 + \dots + 1\beta_1^i)}{\beta_1^i p^*} \\ &= \|u\|_{p^*} C^{a_i}(\beta_1)^{b_i}, \end{aligned} \tag{5.36}$$

where $a_i = (\beta_1 + \beta_1^2 + \dots + \beta_1^i)/p^* \beta_1^i$ and $b_i = \sum_{j=1}^i \frac{j p}{p^* \beta_1^{j-1}}$. Since $\beta_1 > 1$, the sequence $(b_i)_{i \in \mathbb{N}}$ is convergent. Taking limit in (5.36), we get $\|u\|_{\infty} \leq C_1 \|u\|_{p^*}$. This completes the proof of the Lemma. \square

Acknowledgements. The author wishes to thank Jianfu Yang for his suggestions in the study of this problem, and also to thank João Marcos Bezerra do Ó for the corrections in the writing of this text.

References

- [1] Adimurthi and G. Mancini, *The Neumann problem for elliptic equations with critical nonlinearity*. Nonlinear analysis, 9–25, Quaderni, Scuola Norm. Sup., Pisa, 1991.
- [2] Adimurthi, Filomena Pacella and S.L. Yadava, *Interaction between the geometry of the boundary and positive solutions of a semilinear Neumann problem with critical nonlinearity*. J. Funct. Anal. **113** (1993), no. 2,
- [3] T. Aubin, *Nonlinear Analysis on Monge-Ampère Equations*, Springer-Verlag, New York, (1982).
- [4] P. Cherrier, *Meilleures constantes dans des inégalités relatives aux espaces de Sobolev. (French) [Best constants in inequalities involving Sobolev spaces]*. Bull. Sci. Math. (2) **108** (1984) 225–262.
- [5] E.A.M. de Abreu, J.M.B do Ó and E.S. Medeiros, *Multiplicity of positive solutions for a class of quasilinear nonhomogeneous Neumann problems*. Nonlinear Analysis **60** (2005) 1443–1471.
- [6] M. del Pino and C. Flores, *Asymptotics of Sobolev embeddings and singular perturbations for the p -Laplacian*. Proc. Amer. Math. Soc. **130** (2002) 2931–2939.
- [7] E.F. Keller and L.A. Segal, *Initiation of Slime mold aggregation viewed as an instability*, J. Theory. Biol., **26** (1970) 399–415.
- [8] M.G. Lieberman, *Boundary regularity for solutions of degenerate elliptic equations*. Nonlinear Anal. **12** (1988) 1203–1219.
- [9] C.S. Lin, W.M. Ni and I. Takagi, *Large amplitude stationary solutions to a chemotaxis system*. J. Differential Equations **72** (1988) 1–27.
- [10] P.L. Lions, *The Concentration Compactness principle in the Calculus of Variations*, The limit case (Part 1 and Part 2), Rev. Mat. Iberoamericana **1** (1985) 145–201, 45–121.
- [11] W.M. Ni and I. Takagi, *On the shape of least-energy solutions to a semilinear Neumann problem*. Comm. Pure Appl. Math. **44** (1991) 819–851.

- [12] P. Pucci and J. Serrin, *A general variational identity*. Indiana Univ. Math. J. **35** (1986) 681–703.
- [13] P. Tolksdorf, *Regularity for a More General Class of Quasilinear Elliptic Equations*, J. Diff. Equations **51** (1984) 126–150.
- [14] J.L. Vázquez, *A strong maximum principle for some quasilinear elliptic equations*. Appl. Math. Optim. **12** (1984) 191–202.
- [15] X.J. Wang, *Neumann problems of semilinear elliptic equations involving critical Sobolev exponents*. J. Differential Equations **93** (1991) 283–310.
- [16] M. Willem, *Minimax theorems*, Birkhäuser Boston, Inc., Boston, 1996.

Everaldo S. Medeiros
Departamento de Matemática
Univ. Fed. Paraíba
58059-900 João Pessoa, PB
Brazil
e-mail: everaldo@mat.ufpb.br

A-priori Bounds and Positive Solutions to a Class of Quasilinear Elliptic Equations

Marcelo Montenegro and Francisco O. V. de Paiva

This note is dedicated to Djairo G. de Figueiredo on the occasion of his 70th birthday.

Abstract. We prove a-priori estimates for positive solutions u of the equation $-div(|\nabla u|^{p-2}\nabla u) = f(u)$ on a bounded domain Ω with $u = 0$ on $\partial\Omega$ and $1 < p < 2$. Whenever $f(u) = u^q$ our results include the range $p-1 < q < p^* - 1$ and nonconvex domains.

Mathematics Subject Classification (2000). 35J65, 35B45, 35J20, 35J60.

1. Introduction

Let $u \in C^{1,\alpha}(\overline{\Omega})$ be a positive solution of

$$\begin{cases} -\Delta_p u = f(u) & \text{in } \Omega \\ u = 0 & \text{on } \partial\Omega \end{cases} \quad (1)$$

where $\Omega \subset \mathbb{R}^N$, $N \geq 2$, is a smooth bounded domain, $-\Delta_p u = -div(|\nabla u|^{p-2}\nabla u)$, $1 < p < \infty$. The function $f : \mathbb{R} \rightarrow [0, \infty)$ is locally Lipschitz continuous and satisfying the following assumptions:

$$f(s) \geq c_1 s^q \quad \forall s \geq 0 \quad \text{for } c_1 > 0 \text{ and } q > p - 1, \quad (2)$$

$$\exists k > 0 \text{ such that } f(s) \leq c_2 s^{p-1} \quad \text{for } 0 \leq s \leq k \quad \text{where } c_2 > 0, \quad (3)$$

$$\lim_{s \rightarrow \infty} \frac{f(s)}{s^{p^*-1}} = 0 \quad \text{where } p^* = \frac{pN}{N-p} \text{ and } p < N, \quad (4)$$

$$\limsup_{s \rightarrow \infty} \frac{s f(s) - \tau F(s)}{s^{\frac{p(N-p+1)}{N}} f(s)^{\frac{p}{N}}} \leq 0 \quad \text{for some } 0 \leq \tau < p^*. \quad (5)$$

Condition (5) is immediately satisfied in the purely power case whenever $f(u) = u^q$ with $p - 1 < q < p^* - 1$. Moreover, by (11) in the proof of Theorem 2.1 one concludes that we may allow $c_1 u^q \leq f(u) \leq c_2 u^q$ without assuming (5), provided $c_1 p^* > c_2(q + 1)$. This makes $\|\nabla u\|_{L^p}$ bounded, then we proceed as in (12). These

a-priori bounds are important to prove existence of positive solutions, see Theorem 2.3, see also [2, 5, 6].

The blow-up technique of [6] was employed in [2] to ensure that u is a-priori bounded, provided Ω is strictly convex (i.e. $\forall x, y \in \overline{\Omega}, tx+(t-1)y \in \Omega, \forall t \in (0, 1)$), $1 < p < 2$ and $c_1u^q \leq f(u) \leq c_2u^q$ with $p - 1 < q \leq \frac{N(p-1)}{N-p}$ and $c_1, c_2 > 0$. This result was improved in [10] to $1 < p < N$ without the convexity assumption. In the present note we follow the approach of [5] to establish stronger results, including a more general function $f, p - 1 < q < p^* - 1$ and nonconvex domains Ω .

2. Statements and proofs

Theorem 2.1. *Let $u \in C^{1,\alpha}(\overline{\Omega})$ be a positive solution of (1). Assume Ω is strictly convex, $1 < p < 2$, (2), (3), (4) and (5). Then $\|u\|_{C^0(\overline{\Omega})}$ is a-priori bounded.*

Proof. Here $C > 0$ are various constants independent of u and that may change from place to place. By Picone’s identity [1] and (2) we obtain

$$c_1 \int_{\Omega} u^{q-p+1} \varphi_1^p \leq \int_{\Omega} \frac{f(u)}{u^{p-1}} \varphi_1^p \leq \lambda_1 \int_{\Omega} \varphi_1^p, \tag{6}$$

where λ_1 is the first eigenvalue of $-\Delta_p$ and $\varphi_1 \in W_0^{1,p}(\Omega)$ is the corresponding eigenfunction.

We proceed to prove that $u(x) \leq C$ on a thin strip $S_{\delta} = \{x \in \overline{\Omega} : \text{dist}(x, \partial\Omega) < \delta\}$ for some $\delta > 0$. For this aim it is used the moving planes argument as in [2, 3, 5]. There are constants $\gamma > 0$ and $\delta > 0$, depending only on Ω , such that for every $x \in S_{\delta}$ there is a measurable set I_x with the properties: $|I_x| \geq \gamma, I_x \subset \{z \in \Omega : \text{dist}(z, \partial\Omega) > \delta/2\}$ and $u(y) \geq u(x), \forall y \in I_x$. Joining these properties with (6) we obtain

$$u(x)^{q-p+1} \gamma \left(\min_{y \in I_x} \varphi_1^p(y)\right) \leq \int_{I_x} u(y)^{q-p+1} \varphi_1(y) dy \leq C.$$

Consequently,

$$u(x) \leq C, \forall x \in S_{\delta}. \tag{7}$$

We are ready to obtain an a-priori bound of $|\nabla u|$ on a thinner strip Σ than S_{δ} . The interior $C^{1,\alpha}$ estimates of [4] imply

$$\|u\|_{C^{1,\alpha}(\Omega_0)} \leq C \quad \text{where } \Omega_0 = \{z \in \Omega : \frac{\delta}{3} < \text{dist}(z, \partial\Omega) < \frac{\delta}{2}\}.$$

By virtue of the $C^{1,\alpha}$ estimates up to the boundary due to [8], we conclude that

$$\|u\|_{C^{1,\alpha}(\overline{\Sigma})} \leq C \quad \text{where } \Sigma = \{z \in \Omega : \text{dist}(z, \partial\Omega) < \frac{5\delta}{12}\}. \tag{8}$$

The previous estimates allows us to get an a-priori bound for $\|\nabla u\|_{L^p}$. Hypothesis (3) and (7) imply $f(u(x)) \leq Cu(x)^{p-1}$ for every $x \in S_{\delta}$, therefore

$$\int_{\Omega} \frac{f(u)}{u^{p-1}} \leq C, \tag{9}$$

since the integral of $f(u)/u^{p-1}$ over $\Omega - S_\delta$ is bounded by (6). By Sobolev imbedding, (9) and Hölder inequality one obtains

$$\begin{aligned} \int_{\Omega} |\nabla u|^p &\geq C \left(\int_{\Omega} u^{\frac{pN}{N-p}} \right)^{\frac{N-p}{N}} \geq C \left(\int_{\Omega} u^{\frac{pN}{N-p}} \right)^{\frac{N-p}{N}} \left(\int_{\Omega} \frac{f(u)}{u^{p-1}} \right)^{\frac{p}{N}} \\ &\geq C \int_{\Omega} u^p \left(\frac{f(u)}{u^{p-1}} \right). \end{aligned} \tag{10}$$

We shall use the Pohozaev identity and (8) to obtain

$$(p - N) \int_{\Omega} |\nabla u|^p + pN \int_{\Omega} F(u) = (p - 1) \int_{\partial\Omega} |\nabla u|^p (x \cdot \nu) d\sigma \leq C. \tag{11}$$

Estimates (10) and (11) together with condition (5) imply

$$\begin{aligned} \int_{\Omega} u f(u) &\leq \tau \int_{\Omega} F(u) + \varepsilon \int_{\Omega} u^{\frac{p}{N}(N-p+1)} f(u)^{\frac{p}{N}} + C_\varepsilon \\ &\leq \left(\frac{N-p}{pN} \right) \tau \int_{\Omega} f(u) u + \varepsilon C \int_{\Omega} f(u) u + C_\varepsilon, \end{aligned}$$

where $\varepsilon > 0$ can be assumed to be very small and $C_\varepsilon > 0$ is a large constant depending only on ε . Then $\|\nabla u\|_{L^p} \leq C$. Multiplying equation (1) by u^α with $\alpha > 1$ to be chosen later, we obtain

$$\alpha \left(\frac{p}{\alpha + p - 1} \right)^p \int_{\Omega} |\nabla (u^{\frac{\alpha+p-1}{p}})|^p = \int_{\Omega} f(u) u^\alpha. \tag{12}$$

Estimating the left hand side by Sobolev inequality and using (4) yields

$$\left(\int_{\Omega} u^{\frac{(\alpha+p-1)N}{N-p}} \right)^{\frac{N-p}{N}} \leq \varepsilon C \int_{\Omega} u^{p^*-p} u^{\alpha-1+p} + C_\varepsilon \leq \varepsilon C \left(\int_{\Omega} u^{p^*} \right)^{\frac{p}{N}} \left(\int_{\Omega} u^s \right)^{\frac{N-p}{N}} + C_\varepsilon$$

where $s = \frac{(\alpha-1+p)N}{N-p}$. Thus $\int_{\Omega} f(u)^{\frac{s}{p^*-1}} \leq C$. An estimate of Moser type, see for instance [9], says that $\|u\|_{C^0(\overline{\Omega})} \leq C$ if $s > \frac{N(p^*-1)}{p}$, so we take α large enough in order to comply this condition. \square

The convexity assumption on Ω could be removed at the price of a restriction on the growth of f . For this aim we need the Hardy-Sobolev inequality in the form stated in [7]:

$$\left\| \frac{u}{\varphi_1^\theta} \right\|_{L^s} \leq C \|\nabla u\|_{L^r} \quad \text{where } \frac{1}{s} = \frac{1}{r} - \frac{1-\theta}{N} \text{ and } u \in W_0^{1,r}(\Omega), \tag{13}$$

the constant C depends only on θ, s, r, Ω and N .

Theorem 2.2. *Let $\Omega = \Omega_2 \setminus \overline{\Omega}_1$ with Ω_2 strictly convex and Ω_1 a star-shaped subdomain of Ω_2 . Assume $1 < p < 2$, (2), (3), (4) and*

$$\limsup_{s \rightarrow \infty} \frac{s f(s) - \tau F(s)}{s^{\frac{p(N+2-p)}{N+1}} f(s)^{\frac{p}{N}}} \leq 0 \quad \text{for some } 0 \leq \tau < p^*. \tag{14}$$

Then $\|u\|_{C^0(\overline{\Omega})}$ is a-priori bounded.

Proof. We use inequality (13) and proceed as in (10), we just need the estimate

$$\int_{\Omega} |\nabla u|^p \geq C \left(\int_{\Omega} \frac{u^q}{\varphi_1^{\frac{\theta q}{q}}} \right)^{\frac{p}{q}} \left(\int_{\Omega} \frac{f(u)}{u^{p-1}} \varphi_1 \right)^{\frac{p-q}{q}} \geq C \int_{\Omega} \frac{u^p}{\varphi_1^{p\theta}} \left(\frac{f(u)}{u^{(p-1)\frac{q-p}{q}}} \right)^{\frac{q-p}{q}} \varphi_1^{\frac{q-p}{q}}.$$

To finish the proof use (14) with $q = \frac{pN}{N-p-p\theta}$, $\theta = \frac{1}{N+1}$ and Pohozaev identity (11) taking into account the integral over $\partial\Omega_1$ and $\partial\Omega_2$. \square

The following result for $p = 2$ was proved in [5]. Our approach is similar, we define a sequence of approximated problems. We use a-priori estimates to obtain $W_0^{1,p}$ and L^∞ bounds for the sequence of solutions and then pass to the limit.

Theorem 2.3. *Let the assumptions of Theorems 2.1 or 2.2 hold, except (5) or (14). Moreover, assume that*

$$\limsup_{s \rightarrow 0} \frac{f(s)}{s^{p-1}} < \lambda_1, \tag{15}$$

then the problem (1) has a nontrivial solution.

Proof. Let s_n be a sequence of numbers such that $s_n \geq 1$ and $s_n \rightarrow \infty$. Define $\mu_n = f(s_n)/s_n^{-q}$ and a modified function $f_n : \mathbb{R}^+ \rightarrow \mathbb{R}^+$ by

$$f_n(s) = \begin{cases} f(s) & \text{for } 0 \leq s \leq s_n \\ f(s_n) + \mu_n(s - s_n)^q & \text{for } s \geq s_n, \end{cases}$$

where q is given in (2). Let $F_n(s) = \int_0^s f_n(t) dt$, then there exists θ_n with $0 \leq \theta_n < 1/p$ and s'_n such that

$$F_n(s) \leq \theta_n s f_n(s) \text{ for } s \geq s'_n. \tag{16}$$

Step 1: For each n there exists $b_n > 0$ and $u_n \in C^2(\overline{\Omega})$ such that

$$\begin{aligned} -\Delta_p u_n &= f_n(u_n) & \text{in } \Omega \\ u_n &> 0 & \text{on } \partial\Omega \\ u_n &= 0 & \text{on } \partial\Omega, \end{aligned} \tag{17}$$

and $F_n(u_n) = b_n$.

Indeed, consider the functional

$$\Phi_n(v) = \frac{1}{p} \int_{\Omega} |\nabla v|^p dx - \int_{\Omega} F_n(v) dx, \quad v \in W_0^{1,p}.$$

We observe that Φ_n satisfies the hypothesis of the mountain pass theorem. In fact, by (16) Φ_n satisfies the Palais-Smale condition. We proceed to prove that Φ_n possesses the geometry of mountain pass theorem.

Φ_n has a local minimum at 0: By (15) and (4) we have that there exists $\ell < \lambda_1$ and a constant C such that

$$f(s) \leq \ell s^{p-1} + C s^{p^*-1} \text{ for all } s \in \mathbb{R}^+;$$

moreover, we can suppose that

$$f(s) \leq C s^{p^*-1} \text{ for all } s \geq 1.$$

Consequently

$$f_n(s) \leq \ell s^{p-1} + C s^{p^*-1} \text{ for all } s \leq s_n.$$

For $s \geq s_n$, we have

$$\begin{aligned} f_n(s) &= f_n(s_n) + \frac{f_n(s_n)}{s_n^q} (s - s_n)^q \\ &\leq C s_n^{p^*-1} + C s_n^{p^*-1-q} s^q \\ &\leq 2C s^{p^*-1}. \end{aligned}$$

Thus

$$f_n(s) \leq \ell s^{p-1} + C s^{p^*-1} \text{ for all } n \text{ and } s \in \mathbb{R}^+;$$

and we get

$$F_n(s) \leq \ell s^p + C s^{p^*} \text{ for all } n \text{ and } s \in \mathbb{R}^+.$$

Then

$$\begin{aligned} \Phi_n(v) &= \frac{1}{2} \int_{\Omega} |\nabla v|^p dx - \int_{\Omega} F_n(v) dx \\ &\geq \frac{1}{2} \int_{\Omega} |\nabla v|^p dx - \ell \int_{\Omega} v^p + C \int_{\Omega} v^{p^*} \\ &\geq \frac{1}{2} \left(1 - \frac{\ell}{\lambda_1}\right) \|v\|_{W_0^{1,p}}^p - C \|u\|_{W_0^{1,p}}^{p^*}, \end{aligned}$$

so there exists $\rho > 0$ and $\eta > 0$ such that $\Phi_n(v) \geq \eta$ for $\|v\|_{W_0^{1,p}} = \rho$.

There exists $w \in W_0^{1,p}$ such that $\Phi_n(w) \leq 0$ for all n : We will show that there exists a constant c such that for all n

$$\frac{f_n(s)}{s^q} \geq c \text{ for all } s \in \mathbb{R}^+.$$

Indeed, by (2) and the definition of f_n , for $s \leq s_n$ we have that $f_n(s)/s^p \geq c_1$. For $s > s_n$, we distinguish three cases:

Case $q > 1$: We have that

$$\begin{aligned} \frac{f_n(s)}{s^q} &= \frac{f_n(s_n)}{s^q} + \frac{f_n(s_n)}{s_n^q} \frac{(s - s_n)^q}{s^q} \\ &= \frac{f_n(s_n)}{s_n^q} \left(\frac{s_n^q}{s^q} + \frac{(s - s_n)^q}{s^q} \right) \\ &\geq c_1 \left(\frac{s_n^q}{s^q} + \frac{(s - s_n)^q}{s^q} \right) \end{aligned}$$

Consider the real function $h : [s_n, \infty) \rightarrow \mathbb{R}^+$

$$h(s) = \frac{s_n^q}{s^q} + \frac{(s - s_n)^q}{s^q},$$

since $q > 1$ this function satisfies $2/2^q \leq h(s) \leq 1$. Thus

$$\frac{f_n(s)}{s^q} \geq \frac{2}{2^q} c_1 \text{ for all } s \in \mathbb{R}^+.$$

Case $q < 1$: In this case $h(s) \geq 1$, thus

$$\frac{f_n(s)}{s^q} \geq c_1 \text{ for all } s \in \mathbb{R}^+.$$

Case $q = 1$: Observe that

$$\begin{aligned} \frac{f_n(s)}{s} &= \frac{f_n(s_n)}{s} + \frac{f_n(s_n)}{s_n} \frac{(s - s_n)}{s} \\ &= \frac{f_n(s_n)}{s_n} \\ &\geq c_1. \end{aligned}$$

Therefore

$$F_n(s) \geq \frac{c}{q+1} s^{q+1} \text{ for all } s \in \mathbb{R}^+.$$

Let φ_1 be the positive eigenfunction associated with λ_1 . We have

$$\begin{aligned} \Phi_n(r\varphi_1) &= \frac{r^p}{2} \int_{\Omega} |\nabla \varphi_1|^p dx - \int_{\Omega} F_n(r\varphi_1) dx \\ &\leq \frac{\lambda_1 r^p}{2} \int_{\Omega} \varphi_1^p dx - \frac{r^{p+1}c}{p+1} \int_{\Omega} \varphi_1^{q+1}, \end{aligned}$$

and since, $p < q + 1$, we can choose $R > 0$ such that $\Phi_n(R\varphi_1) \leq 0$ for all n .

Let $\Gamma = \{\gamma \in C([0, 1], W_0^{1,p}); \gamma(0) = 0 \text{ and } \gamma(1) = w\}$ and set

$$b_n = \inf_{\gamma \in \Gamma} \sup_{t \in [0,1]} \Phi_n(\gamma(t)).$$

Then $b_n \geq \eta$ and there exists $u_n \in C^1(\bar{\Omega})$ solution of problem (17) with $\Phi_n(u_n) = b_n$. Moreover, it follows that b_n is bounded from above.

Step 2: There exist positive constants C_1 and C_2 such that $C_1 \leq \|u_n\|_{L^\infty} \leq C_2$.

We first obtain that $\{\|u_n\|_{W_0^{1,p}}\}$ is bounded. Let C such that $b_n \leq C$. Now, observing that f_n satisfies (4) uniformly in n and using the proof of Theorem 2.1, we obtain

$$|\nabla u_n(x)| \leq C, \text{ for all } x \in \partial\Omega_1.$$

By the Pohozaev identity

$$(p - N) \int_{\Omega} |\nabla u_n|^p dx + pN \int_{\Omega} F_n(u_n) dx = (p - 1) \int_{\partial\Omega} |\nabla u|^p(x \cdot \nu) d\sigma \leq C.$$

But

$$b_n = \frac{1}{p} \int_{\Omega} |\nabla u_n|^p dx - \int_{\Omega} F_n(u_n) dx \leq C,$$

therefore $\|u_n\|_{W_0^{1,p}}^p \leq C$, and it implies that $\|u_n\|_{L^\infty} \leq C$ (by the same arguments as in the proof of Theorem 2.1). It implies that u_n is a critical point of Φ for all n , where

$$\Phi(v) = \frac{1}{p} \int_{\Omega} |\nabla v|^p dx - \int_{\Omega} F(v) dx, \quad v \in W_0^{1,p}.$$

And so we have

$$0 = \Phi'(u_n)u_n = \int_{\Omega} |\nabla u_n|^p - \int_{\Omega} f(u_n)u_n,$$

thus $C \leq \|u_n\|_{W_0^{1,p}}^p \leq \ell \|u_n\|_{L^\infty}^p + C \|u_n\|_{L^\infty}^{p^*}$, and so we have that $C \leq \|u_n\|_{L^\infty}$.

The proof of Theorem 2.3 follows from the fact that the weak limit of u_n is nontrivial. \square

Acknowledgement. Marcelo Montenegro was partially supported by CNPq 478896/2003-4 and FAPESP 04/06678-0. F. O. V de Paiva was supported by Prodoc-CAPES.

References

- [1] W. Allegretto and Y. X.Huang, *A Picone's identity for the p -Laplacian and applications*, *Nonlinear Anal.* **32** (1998) 819–830.
- [2] C. Azizieh and P. Clément, *A-priori estimates and continuation methods for positive solutions of p -Laplace equations*, *J. Differential Equations* **179** (2002), 213–245.
- [3] L. Damascelli and F. Pacella, *Monotonicity and symmetry of solutions of p -Laplace equations, $1 < p < 2$, via the moving plane method*, *Ann. Scuola Norm. Sup. Pisa Cl. Sci.* (4) **26** (1998) 689–707.
- [4] E. DiBenedetto *$C^{1+\alpha}$ local regularity of weak solutions of degenerate elliptic equations*, *Nonlinear Anal.* **7** (1983), 827–850.
- [5] D. G. de Figueiredo, P.-L. Lions and R. Nussbaum, *A-priori estimates and existence of positive solutions of semilinear elliptic equations*, *J. Math. Pures Appl.* **61** (1982), 41–63.
- [6] B. Gidas and J. Spruck, *A-priori bounds for positive solutions of nonlinear elliptic equations*, *Comm. Partial Differential Equations* **6** (1981), 883–901.
- [7] O. Kavian, *Inégalité de Hardy-Sobolev*, *C. R. Acad. Sci. Paris Sér. A-B* **286** (1978), 779–781.
- [8] G. Lieberman, *Boundary regularity for solutions of degenerate elliptic equations*, *Nonlinear Anal.* **12** (1988), 1203–1219.
- [9] M. Ôtani, *Existence and nonexistence of nontrivial solutions of some nonlinear degenerate elliptic equations*, *J. Funct. Anal.* **76** (1988) 140–159.
- [10] D. Ruiz, *A-priori estimates and existence of positive solutions for strongly nonlinear problems*, *J. Differential Equations* **199** (2004) 96–114.

Marcelo Montenegro and Francisco O. V. de Paiva
 Universidade Estadual de Campinas, IMECC
 Departamento de Matemática
 Caixa Postal 6065
 CEP 13083-970, Campinas, SP
 Brazil
 e-mail: msm@ime.unicamp.br
 odair@ime.unicamp.br

The Role of the Equal-Area Condition in Internal and Superficial Layered Solutions to Some Nonlinear Boundary Value Elliptic Problems

Arnaldo Simal do Nascimento and Renato José de Moura

Dedicated to Prof. Djairo G. de Figueiredo on his seventieth birthday.

Mathematics Subject Classification (2000). 35B25, 35B35, 35K57, 35R35.

Keywords. Reaction-diffusion equation, internal and superficial transition layers, equal-area condition, nonlinear boundary condition.

1. Introduction

Somehow we have become acquainted with the so called equal-area condition (or rule) in the set of hypotheses whenever one wishes to show existence of a family of solutions to scalar semilinear elliptic equation with Neumann boundary condition which develops internal transition layers, as a certain parameter varies. Sometimes the equal-area condition also appears in a disguised form by requiring that the potential in a typical energy functional is of the type double-well.

The reader is referred to [6], where some examples requiring the equal-area condition are collected from the vast literature on the subject. See also [4], [3] and [7].

For each phenomenon the mathematical problem models there is a physical mechanism of balance underlying the equal-area condition whenever internal transition layer is created.

In [5] for a singularly perturbed scalar elliptic problem and in [6] for a class of reaction-diffusion systems, we proved that when there is no explicit space-variable dependency, the equal-area condition is actually a necessary hypothesis if a family

of solutions is to develop internal transition layer. In both cases we had the zero Neumann boundary condition.

It is our purpose herein to prove that in order for a typical singularly perturbed elliptic problem with nonlinear Neumann boundary condition to develop internal and superficial transition layers the equal-area condition must hold not only for the reaction term on the domain but for the reaction term on its boundary as well.

The elliptic nonlinear boundary value problem which will be the focus of our attention is

$$\begin{cases} \varepsilon \operatorname{div}(a(x)\nabla v_\varepsilon) + f(x, v_\varepsilon) = 0, & x \in \Omega \\ \varepsilon a(x) \frac{\partial v_\varepsilon}{\partial \hat{n}} = g(x, v_\varepsilon), & x \in \partial\Omega, \end{cases} \tag{1.1}$$

where $\Omega \subset \mathbb{R}^N$ ($N \geq 2$) is a bounded domain with C^2 boundary, \hat{n} the exterior normal vector field on $\partial\Omega$, $a \in C^1(\overline{\Omega})$, $a > 0$ and $f : \Omega \times \mathbb{R} \rightarrow \mathbb{R}$ and $g : \partial\Omega \times \mathbb{R} \rightarrow \mathbb{R}$ are of class C^1 .

Loosely speaking our main result may be stated as follows for $N = 3$. Suppose that there are functions $\alpha, \beta \in C^1(\overline{\Omega})$ with $\alpha(x) < \beta(x)$, $\forall x \in \overline{\Omega}$, and a family $\{u_\varepsilon\} \in C^1(\overline{\Omega})$ of solutions to (1.1) which, as $\varepsilon \rightarrow 0$, jumps from values close to α to values close to β across a 2-dimensional surface $S \subset \Omega$ (internal interface) and also across the closed curve $\partial S \subset \partial\Omega$ (superficial interface).

Then necessarily

$$\int_{\alpha(x)}^{\beta(x)} f(x, \xi) d\xi = 0, \quad \forall x \in S \quad \text{and} \quad \int_{\alpha(y)}^{\beta(y)} g(y, \xi) d\xi = 0, \quad \forall y \in \partial S.$$

For the special case that α and β are constants and f and g do not depend explicitly on the spatial variable, we obtain the two equal-area conditions, i.e., $\int_{\alpha}^{\beta} f(\xi) d\xi = \int_{\alpha}^{\beta} g(\xi) d\xi = 0$. Actually in [2], under these two equal-area conditions, existence of a family of solutions to (1.1) as above has been proved for $N = 3$, $a \equiv 1$ and $f(x, v) = f(v)$ and $g(x, v) = g(v)$ having two zeros α and β .

In [11] problem (1.1) was considered with $N = 2$, $a \equiv 1$, $f \equiv 0$ and $g(y, u) = u(1 - u)(c(y) - u)$. Here $c \in C^1(\partial\Omega)$, $0 < c(y) < 1$ is such that $\Sigma \stackrel{\text{def}}{=} \{y \in \partial\Omega : c(y) = 1/2\} \neq \emptyset$ and it satisfies a transversality condition on Σ . In this case our result states that a necessary condition for the existence of a family of solutions concentrating around 0 and 1 on $\partial\Omega$ with interface at a point y in the closed curve $\partial\Omega$ is that

$$0 = \int_0^1 (\xi(1 - \xi)(c(y) - \xi)) d\xi = \frac{1}{6}(c(y) - \frac{1}{2}),$$

i.e., $y \in \Sigma$. Indeed under the above hypotheses the existence of such solutions has been proved in [11].

The point here is that Σ cannot be empty if the existence of a superficial transition layer is to be proved. It is also worth mentioning the fact that the location of any possible boundary interface is usually difficult to determine. But in these results, it is known a-priori.

2. The meaning of internal and superficial transition layer

We want our notion of transition layers to be local in space thus allowing for other type of concentration phenomena to take place in the domain. But this requires some care while defining a convenient neighborhood of the surface which will give rise to the interface.

Let S be a $(N - 1)$ -dimensional surface of class C^2 , with boundary, which partitions Ω into two nonempty open disjoint subsets Ω_α and Ω_β . Moreover suppose that $\Sigma \stackrel{\text{def}}{=} \partial S$, the boundary of S , is a $(N - 2)$ -dimensional compact surface of class C^2 without boundary satisfying $\Sigma = \overline{S} \cap \partial\Omega$ and that \overline{S} intersect $\partial\Omega$ transversally.

Let W be any open neighborhood of \overline{S} and setting

$$V_l \stackrel{\text{def}}{=} (W \cap \Omega_l) \setminus S, \quad l \in \{\alpha, \beta\} \tag{2.1}$$

we define

$$V \stackrel{\text{def}}{=} V_\alpha \cup S \cup V_\beta \quad (\subset \Omega).$$

Regarding the boundary of Ω we set

$$M_l \stackrel{\text{def}}{=} (\partial V_l \cap \partial\Omega) \setminus \Sigma, \quad l \in \{\alpha, \beta\}$$

and define

$$M \stackrel{\text{def}}{=} M_\alpha \cup \Sigma \cup M_\beta \quad (\subset \partial\Omega).$$

Finally let $\alpha, \beta \in C^1(\overline{\Omega})$ satisfying $\alpha(x) < \beta(x)$ in $\overline{\Omega}$ and define a function v_0 in \overline{V} by

$$v_0(x) = \alpha(x)\chi_{V_\alpha \cup M_\alpha} + \beta(x)\chi_{V_\beta \cup M_\beta} \tag{2.2}$$

where χ_A denotes the characteristic function of a set A .

Definition 2.1. A family $\{v_\varepsilon\}$ of solutions to (1.1) in $C^2(\Omega) \cap C^1(\overline{\Omega})$ is said to develop an internal and superficial transition layer, as $\varepsilon \rightarrow 0$, with interfaces S and Σ , respectively, if

$$(v_\varepsilon|_V, v_\varepsilon|M) \xrightarrow{\varepsilon \rightarrow 0} (v_0|_V, v_0|M) \text{ in } L^1(V) \times L^1(M),$$

with v_0 given by (2.2).

In particular we may have $V = \Omega$ and $M = \partial\Omega$.

Remark 2.2. Our main result would still remain valid had the convergence in $L^1(V) \times L^1(M)$ in Definition 2.1 been replaced with uniform convergence on compact sets in $V \setminus S$ and $M \setminus \Sigma$ or with $L^p(V) \times L^p(M)$ ($p \geq 2$).

The proof still goes through without any modification and the only reason the $L^1(V) \times L^1(M)$ -convergence was chosen is that for this case we do have an example that realizes Definition 2.1 for $N \geq 2$ and f and g not identically zero. See [2], for this matter.

Remark 2.3. Regarding Definition 2.1, the question might be raised as to whether the requirement on the convergence of the solutions on $\partial\Omega$ is redundant in the sense that once the convergence on Ω is required the convergence on $\partial\Omega$ would follow by continuity of the trace operator acting from $W^{1,p}(\Omega)$ ($p \geq 2$) to $W^{1-1/p,p}(\partial\Omega)$. However since v_0 does not belong to $W^{1,p}(\Omega)$ the convergence $v_\varepsilon \rightarrow v_0$ cannot take place in any of this spaces.

On the other hand since $v_0 \in BV(\Omega)$ (the space of functions of bounded variation in Ω) it would make sense to require convergence only in $BV(\Omega)$ once the trace operator is continuous from $BV(\Omega)$ to $L^1(\partial\Omega)$. However even in this case there would be no guarantee that the traces of the solutions converged to $v_0|_{\partial\Omega}$ in $L^1(\partial\Omega)$. One is referred to [1] for a discussion on this matter.

Remark 2.4. In Definition 2.1 we could have suppressed either the internal interface S or the superficial interface Σ thus obtaining the equal-area condition for g when $f \equiv 0$ and for f when $g \equiv 0$, respectively.

3. Main result

Theorem 3.1. *Let $\{v_\varepsilon\}_{0 < \varepsilon \leq \varepsilon_0}$ be a family of $C^2(\Omega) \cap C^1(\bar{\Omega})$ solutions to (1.1), uniformly bounded in $\bar{\Omega}$ with respect to ε , which develops an internal and superficial transition layer, as $\varepsilon \rightarrow 0$, with interfaces S and Σ (in the sense of Definition 2.1). Then*

$$\int_{\alpha(x)}^{\beta(x)} f(x, \xi) d\xi = 0, \quad \forall x \in S \quad \text{and} \quad \int_{\alpha(y)}^{\beta(y)} g(y, \zeta) d\zeta = 0, \quad \forall y \in \Sigma. \quad (3.1)$$

Moreover $f(x, v_0(x)) = 0, \forall x \in V \setminus S$, and $g(y, v_0(y)) = 0, \forall y \in (\partial V \cap \partial\Omega) \setminus \Sigma$.

The following equalities will be useful in the proof of Theorem 3.1.

Lemma 3.2. *Let $X = (X_1, \dots, X_N) \in C^1(\bar{\Omega}, \mathbb{R}^N)$, $a \in C^1(\bar{\Omega})$ and $v \in C^2(\Omega) \cap C^1(\bar{\Omega})$. Then the following hold:*

- (i) $\operatorname{div}[(X \cdot \nabla) v a(x) \nabla v] = X \cdot \nabla v \operatorname{div}(a(x) \nabla v) + a(x) \nabla v \cdot \nabla(X \cdot \nabla v)$.
- (ii) $a(x) \nabla v \cdot \nabla(X \cdot \nabla v) = a(x) X \cdot \nabla \left(\frac{|\nabla v|^2}{2} \right) + a(x) \left[\sum_{i,j=1}^N \frac{\partial X_i}{\partial x_j} \left(\frac{\partial v}{\partial x_i} \frac{\partial v}{\partial x_j} \right) \right]$.
- (iii) $\operatorname{div}(a X (\frac{|\nabla v|^2}{2})) = a X \cdot \nabla(\frac{|\nabla v|^2}{2}) + \frac{|\nabla v|^2}{2} (a \operatorname{div} X + X \cdot \nabla a)$.
- (iv) *There exists a constant $C = C(a, X, N) > 0$ such that*

$$\left| a(x) \sum_{i,j=1}^N \frac{\partial X_i}{\partial x_j} \left(\frac{\partial v}{\partial x_i} \frac{\partial v}{\partial x_j} \right) \right| < C |\nabla v|^2, \quad \forall x \in \bar{\Omega}.$$

All the proofs can be accomplished with some straightforward computations.

Having in mind a future application of the co-area formula we rather take the neighborhood V considered in Section 2 in the following way. With $\text{dist}(\cdot, \bar{S})$ denoting the usual distance function and S as above, let $W = \{x \in \mathbb{R}^n : d(x) = \text{dist}(x, \bar{S}) \leq \delta\}$ with δ small enough so that the surfaces $K_\alpha \stackrel{\text{def}}{=} d^{-1}\{\delta\} \cap \bar{\Omega}_\alpha$ and $K_\beta \stackrel{\text{def}}{=} d^{-1}\{\delta\} \cap \bar{\Omega}_\beta$ intersect $\partial\bar{\Omega}$ transversally.

Remark that K_α and K_β are C^2 $(N - 1)$ -dimensional surfaces whose boundaries denoted by C_α and C_β , respectively, are $(N - 2)$ -dimensional smooth surfaces.

With this notation $\partial V_l = M_l \cup S \cup K_l$ and $\partial M_l = C_l \cup \Sigma$ where $l \in \{\alpha, \beta\}$.

We will denote by \hat{n}_l and \hat{n}_S the exterior normal vector field on ∂V_l , $l \in \{\alpha, \beta\}$ and S , respectively. Note that $\hat{n}_\alpha = \hat{n}_S$ and $\hat{n}_\beta = -\hat{n}_S$.

Proof of Theorem 3.1. Assume for a while that $f(x, v_0(x)) = 0$, $x \in V \setminus S$, and $g(y, v_0(y)) = 0$, $y \in (\partial V \cap \partial\Omega) \setminus \Sigma$.

Let $X \in C^1(\bar{\Omega}, \mathbb{R}^N)$ be a vector field such that $X_y \in T_y\partial\Omega$, $y \in \partial\Omega$, where $T_y\partial\Omega$ denotes the tangent space to $\partial\Omega$ at y . Multiplying equation (1.1) by $X \cdot \nabla v$, using Lemma 3.2 and integrating over V we obtain

$$\begin{aligned} & -\varepsilon \int_V \text{div}(X \cdot \nabla v_\varepsilon a(x) \nabla v_\varepsilon) dx - \varepsilon \int_V \frac{|\nabla v_\varepsilon|^2}{2} (a \text{div} X + X \cdot \nabla a) dx \\ & + \varepsilon \int_V \text{div}(a(x) X (\frac{|\nabla v_\varepsilon|^2}{2})) dx + \varepsilon \int_V a(x) \left[\sum_{i,j=1}^N \frac{\partial X_i}{\partial x_j} \left(\frac{\partial v_\varepsilon}{\partial x_i} \frac{\partial v_\varepsilon}{\partial x_j} \right) \right] dx \\ & = \int_V X \cdot \nabla v_\varepsilon f(x, v_\varepsilon) dx. \end{aligned}$$

An application of the Divergence Theorem yields

$$\begin{aligned} & - \varepsilon \int_{K_\alpha} \left(X \cdot \nabla v_\varepsilon a(x) \nabla v_\varepsilon \cdot \hat{n}_\alpha - a(x) \frac{|\nabla v_\varepsilon|^2}{2} X \cdot \hat{n}_\alpha \right) d\sigma \\ & - \varepsilon \int_{K_\beta} \left(X \cdot \nabla v_\varepsilon a(x) \nabla v_\varepsilon \cdot \hat{n}_\beta - a(x) \frac{|\nabla v_\varepsilon|^2}{2} X \cdot \hat{n}_\beta \right) d\sigma \\ & - \varepsilon \int_V \frac{|\nabla v_\varepsilon|^2}{2} (a(x) \text{div} X + X \cdot \nabla a(x)) dx \\ & + \varepsilon \int_V a(x) \left[\sum_{i,j=1}^N \frac{\partial X_i}{\partial x_j} \left(\frac{\partial v_\varepsilon}{\partial x_i} \frac{\partial v_\varepsilon}{\partial x_j} \right) \right] dx \\ & = \int_V X \cdot \nabla v_\varepsilon f(x, v_\varepsilon) dx + \int_{\partial V \cap \partial\Omega} X \cdot \nabla v_\varepsilon g(x, v_\varepsilon) d\sigma \tag{3.2} \end{aligned}$$

on the accounts that $K_l = \partial V \cap \Omega_l$ and $X \cdot \hat{n}_l = 0$ in $\partial V_l \cap \partial\Omega$ ($l = \alpha, \beta$). Here σ denotes the $(N - 1)$ -dimensional surface measure.

Let us call Φ_ε the expression on the left-hand side of the above equality. Consequently the equation becomes

$$\begin{aligned} \Phi_\varepsilon &= \int_{V_\alpha \cup V_\beta} X \cdot \nabla_x F(x, v_\varepsilon) dx - \int_{V_\alpha \cup V_\beta} \left(\int_\theta^{v_\varepsilon(x)} X \cdot \nabla_x f(x, \xi) d\xi \right) dx \\ &+ \int_{M_\alpha \cup M_\beta} X \cdot \nabla_x G(x, v_\varepsilon) d\sigma - \int_{M_\alpha \cup M_\beta} \left(\int_\rho^{v_\varepsilon(x)} X \cdot \nabla_x g(x, \zeta) d\zeta \right) d\sigma, \end{aligned} \tag{3.3}$$

where $G(x, v_\varepsilon) = \int_\rho^{v_\varepsilon} g(x, \zeta) d\zeta$ and $F(x, v_\varepsilon) = \int_\theta^{v_\varepsilon} f(x, \xi) d\xi$, with ρ and θ arbitrary constants and ∇_x is the gradient with respect x . Also $\sigma(\Sigma) = 0$ and $|S| = 0$, where $|\cdot|$ stands for the Lebesgue measure.

We claim that Φ_ε tends to zero as $\varepsilon \rightarrow 0$. As the proof involves technical arguments it will be provided afterwards.

Applying the Divergence Theorem once again we have for $l \in \{\alpha, \beta\}$,

$$\begin{aligned} \int_{V_l} X \cdot \nabla_x F(x, v_\varepsilon) dx &= \int_S F(x, v_\varepsilon) X \cdot \hat{n}_l d\sigma + \int_{K_l} F(x, v_\varepsilon) X \cdot \hat{n}_l d\sigma \\ &- \int_{V_l} F(x, v_\varepsilon) \operatorname{div} X dx \end{aligned} \tag{3.4}$$

because $X \cdot \hat{n}_l = 0$ in $\partial V_l \cap \partial\Omega$.

Since $\hat{n}_\alpha = \hat{n}_S$ in $\partial V_\alpha \cap S$ and $\hat{n}_\beta = -\hat{n}_S$ in $\partial V_\beta \cap S$ it follows

$$\begin{aligned} \int_{V_\alpha \cup V_\beta} X \cdot \nabla_x F(x, v_\varepsilon) dx &= \int_{K_\alpha} F(x, v_\varepsilon) X \cdot \hat{n}_\alpha d\sigma + \int_{K_\beta} F(x, v_\varepsilon) X \cdot \hat{n}_\beta d\sigma \\ &- \int_{V_\alpha \cup V_\beta} F(x, v_\varepsilon) \operatorname{div} X dx. \end{aligned} \tag{3.5}$$

For each $x \in M_l$ ($l = \alpha, \beta$),

$$\nabla_x G(x, v_\varepsilon) = \nabla^{M_l} G(x, v_\varepsilon) + \langle \nabla_x G(x, v_\varepsilon), \hat{n} \rangle \hat{n},$$

where $\langle \cdot, \cdot \rangle$ denotes the usual internal product and $\nabla^{M_l} G$ the gradient relative to M_l of the function G . Hence

$$\begin{aligned} X \cdot \nabla_x G(x, v_\varepsilon) &= X \cdot \nabla^{M_l} G(x, v_\varepsilon) + \langle \nabla_x G(x, v_\varepsilon), \hat{n} \rangle X \cdot \hat{n} \\ &= X \cdot \nabla^{M_l} G(x, v_\varepsilon), \end{aligned} \tag{3.6}$$

and the Divergence Theorem on surfaces gives

$$\begin{aligned} \int_{M_l} X \cdot \nabla_x G(x, v_\varepsilon) d\sigma &= \int_{\partial M_l} G(x, v_\varepsilon) X \cdot \nu_l d\tau - \int_{M_l} G(x, v_\varepsilon) \operatorname{div}_{M_l} X d\sigma \\ &= \int_{C_l} G(x, v_\varepsilon) X \cdot \nu_l d\tau + \int_\Sigma G(x, v_\varepsilon) X \cdot \nu_l d\tau \\ &- \int_{M_l} G(x, v_\varepsilon) \operatorname{div}_{M_l} X d\sigma, \end{aligned} \tag{3.7}$$

where ν_l is the outward vector co-normal at ∂M_l , that is, $|\nu_l| = 1$, $\nu_l(y) \in T_y \partial\Omega$, $y \in \partial\Omega$, with $\partial M_l = C_l \cup \Sigma$ ($l = \alpha, \beta$). In $\partial M_\alpha \cap \Sigma$ the co-normal, denoted by

ν_Σ , satisfies $\nu_\alpha = \nu_\Sigma$. Consequently $\nu_\beta = -\nu_\Sigma$ in $\partial M_\beta \cap \Sigma$. Here τ denotes the (N-2)-dimensional surface measure. It follows that

$$\int_{M_\alpha \cup M_\beta} X \cdot \nabla_x G(x, v_\varepsilon) d\sigma = \int_{C_\alpha} G(x, v_\varepsilon) X \cdot \nu_\alpha d\tau + \int_{C_\beta} G(x, v_\varepsilon) X \cdot \nu_\beta d\tau - \int_{M_\alpha \cup M_\beta} G(x, v_\varepsilon) \operatorname{div}_{M_\alpha} X d\sigma. \tag{3.8}$$

Since $\{v_\varepsilon\}_{0 < \varepsilon \leq \varepsilon_0}$ is uniformly bounded in $\overline{\Omega}$ with respect to ε , F and G are C^1 , the sequences $\{F(x, v_\varepsilon)\}_{0 < \varepsilon \leq \varepsilon_0}$ and $\{G(x, v_\varepsilon)\}_{0 < \varepsilon \leq \varepsilon_0}$ are bounded in Ω and $\partial\Omega$, respectively, uniformly in ε . Moreover (up to a subsequence) $v_\varepsilon \xrightarrow{\varepsilon \rightarrow 0} v_0$ a.e. in V and $v_\varepsilon|_{\partial V \cap \partial\Omega} \xrightarrow{\varepsilon \rightarrow 0} v_0|_{\partial V \cap \partial\Omega}$ a.e. in $\partial V \cap \partial\Omega$. The use of Lebesgue theorem in the equations (3.5) and (3.8) yields

$$\begin{aligned} & \lim_{\varepsilon \rightarrow 0} \left(\int_{V_\alpha} X \cdot \nabla F(x, v_\varepsilon) dx + \int_{V_\beta} X \cdot \nabla F(x, v_\varepsilon) dx \right) \\ &= \int_{K_\alpha} F(x, \alpha) X \cdot \hat{n}_\alpha d\sigma + \int_{K_\beta} F(x, \beta) X \cdot \hat{n}_\beta d\sigma \\ & \quad - \int_{V_\alpha} F(x, \alpha) \operatorname{div} X dx - \int_{V_\beta} F(x, \beta) \operatorname{div} X dx \end{aligned} \tag{3.9}$$

and

$$\begin{aligned} & \lim_{\varepsilon \rightarrow 0} \left(\int_{M_\alpha} X \cdot \nabla_x G(x, v_\varepsilon) d\sigma + \int_{M_\beta} X \cdot \nabla_x G(x, v_\varepsilon) d\sigma \right) \\ &= \int_{C_\beta} G(x, \beta) X \cdot \nu_\beta d\tau + \int_{C_\alpha} G(x, \alpha) X \cdot \nu_\alpha d\tau - \int_{M_\alpha} G(x, \alpha) \operatorname{div}_{M_\alpha} X d\sigma \\ & \quad - \int_{M_\beta} G(x, \beta) \operatorname{div}_{M_\beta} X d\sigma. \end{aligned} \tag{3.10}$$

Since $f(x, v_0(x)) = 0$ in $V \setminus S$,

$$\begin{aligned} & \lim_{\varepsilon \rightarrow 0} \int_{V_l} \left[\int_\theta^{v_\varepsilon(x)} X \cdot \nabla_x f(x, \xi) d\xi \right] dx = \int_{V_l} X \cdot \nabla_x F(x, v_0(x)) dx \\ &= \int_{\partial V_l} F(x, v_0) X \cdot \hat{n}_l d\sigma - \int_{V_l} F(x, v_0) \operatorname{div} X dx. \end{aligned}$$

Similarly since $g(x, v_0(x)) = 0$ in $(\partial V \cap \partial\Omega) \setminus S$ then

$$\begin{aligned} \lim_{\varepsilon \rightarrow 0} \int_{M_l} \left[\int_\rho^{v_\varepsilon(x)} X \cdot \nabla_x g(x, \zeta) d\zeta \right] d\sigma &= \int_{M_l} X \cdot \nabla_x G(x, v_0) d\sigma \\ &= \int_{M_l} X \cdot \nabla^{M_l} G(x, v_0) d\sigma. \end{aligned}$$

Using that $\operatorname{div}_{M_l}(XG(x, v_0)) = G(x, v_0)\operatorname{div}_{M_l}X + X \cdot \nabla^{M_l}G(x, v_0)$ and applying Divergence Theorem once more we obtain

$$\int_{M_l} X \cdot \nabla^{M_l}G(x, v_0) d\sigma = \int_{\partial M_l} G(x, v_0)X \cdot \nu_l d\tau - \int_{M_l} G(x, v_0)\operatorname{div}_{M_l}X d\sigma \quad (l = \alpha, \beta). \tag{3.11}$$

Recalling that $X \cdot \widehat{n}_l = 0$ in $\partial V_l \cap \partial\Omega$, $\partial V_l = S \cup M_l \cup K_l$ ($l = \alpha, \beta$), $\widehat{n}_\alpha = \widehat{n}_S$ in $\partial V_\alpha \cap S$ and $\widehat{n}_\beta = -\widehat{n}_S$ in $\partial V_\beta \cap S$ and also $\partial M_l = C_l \cup \Sigma$ ($l = \alpha, \beta$), $\nu_\alpha = \nu_\Sigma$ in $\partial M_\alpha \cap \Sigma$ and $\nu_\beta = -\nu_\Sigma$ in $\partial M_\beta \cap \Sigma$, passing to limit in (3.3), as $\varepsilon \rightarrow 0$, and using (3.9) to (3.11) we conclude that

$$0 = \int_S \left[\int_{\alpha(x)}^{\beta(x)} f(x, \xi) d\xi \right] X \cdot \widehat{n}_S d\sigma + \int_\Sigma \left[\int_{\alpha(x)}^{\beta(x)} g(x, \zeta) d\zeta \right] X \cdot \nu_\Sigma d\tau. \tag{3.12}$$

In order to verify that the last expression implies (3.1) we consider the functional $\Lambda : C^1(\mathbb{R}^N, \mathbb{R}^N) \rightarrow \mathbb{R}$ defined by

$$\Lambda(X) = \int_S \left[\int_{\alpha(x)}^{\beta(x)} f(x, \xi) d\xi \right] X \cdot \widehat{n}_S d\sigma + \int_\Sigma \left[\int_{\alpha(x)}^{\beta(x)} g(x, \zeta) d\zeta \right] X \cdot \nu_\Sigma d\tau.$$

Then for any $\overline{X} \in \Upsilon = \{X \in C^1(\mathbb{R}^N, \mathbb{R}^N) : X(y) \in T_y\partial\Omega\}$ we have

$$\Lambda(\overline{X}) = 0, \tag{3.13}$$

by (3.12).

It is easy to see that once $X \in C^1(\mathbb{R}^N, \mathbb{R}^N)$ is fixed

$$\Lambda'(X)Y = \int_S \left[\int_{\alpha(x)}^{\beta(x)} f(x, \xi) d\xi \right] Y \cdot \widehat{n}_S d\sigma + \int_\Sigma \left[\int_{\alpha(x)}^{\beta(x)} g(x, \zeta) d\zeta \right] Y \cdot \nu_\Sigma d\tau,$$

for any $Y \in C^1(\mathbb{R}^N, \mathbb{R}^N)$.

Thus if $\overline{X} \in \Upsilon$ and $Y \in C^1(\mathbb{R}^N, \mathbb{R}^N)$ with $\operatorname{supp} Y \subset \Omega$, we have $\overline{X} + tY \in \Upsilon, \forall t \in \mathbb{R}$. Thus (3.13) implies

$$0 = \Lambda'(\overline{X})Y = \int_S \left[\int_{\alpha(x)}^{\beta(x)} f(x, \xi) d\xi \right] Y \cdot \widehat{n}_S d\sigma,$$

since $Y|_{\partial\Omega} = 0$.

Now suppose by contradiction that there exists $x_0 \in S$ such that $\int_{\alpha(x_0)}^{\beta(x_0)} f(x_0, \xi) d\xi \neq 0$. Then there exists an open set $A \subset \mathbb{R}^N$ such that

$$\int_{\alpha(x)}^{\beta(x)} f(x, \xi) d\xi > 0, \quad \forall x \in A \cap S.$$

Choose $\bar{Y} \in C^1(\mathbb{R}^N, \mathbb{R}^N)$ so that $\bar{Y}|_S = \hat{n}_S$. Take an open set $U \in \mathbb{R}^N$ so that $U \subset A \cap \Omega$, $U \cap S \neq \emptyset$ and $\eta \in C_c^2(U) = \{\phi \in C^2(U) : \text{supp}(\phi) \subset U\}$ satisfying $0 \leq \eta \leq 1$ and $\eta \equiv 1$ in $B \subset \subset U$, $B \cap S \neq \emptyset$.

If $Y = \eta \bar{Y}$ then $Y \in C^1(\mathbb{R}^N, \mathbb{R}^N)$, $\text{supp } Y \subset \Omega$ and so

$$\begin{aligned} 0 &= \Lambda'(\bar{X})Y = \int_S \left[\int_\alpha^\beta f(x, \xi) d\xi \right] Y \cdot \hat{n}_S d\sigma \\ &= \int_{U \cap S} \left[\int_\alpha^\beta f(x, \xi) d\xi \right] \eta \bar{Y} \cdot \hat{n}_S d\sigma \\ &\geq \int_{B \cap S} \left[\int_\alpha^\beta f(x, \xi) d\xi \right] \eta d\sigma = \int_{B \cap S} \left[\int_\alpha^\beta f(x, \xi) d\xi \right] d\sigma > 0, \end{aligned}$$

which is a contradiction. Hence

$$\int_{\alpha(x)}^{\beta(x)} f(x, \xi) d\xi = 0, \quad \forall x \in S.$$

Consequently

$$\Lambda'(\bar{X})Y = \int_\Sigma \left[\int_\alpha^\beta g(x, \zeta) d\zeta \right] Y \cdot \nu_\Sigma d\tau = 0,$$

$\forall \bar{X} \in \Upsilon$ and $Y \in C^1(\mathbb{R}^N, \mathbb{R}^N)$.

Similarly we prove that $\int_{\alpha(x)}^{\beta(x)} g(x, \zeta) d\zeta = 0, \forall x \in \Sigma$.

Our goal now is to show that $f(x, v_0(x)) = 0$ in $V \setminus S$ and $g(x, v_0(x)) = 0$ in $(\partial V \cap \partial \Omega) \setminus \Sigma$. We claim that for each $x \in \Omega \setminus S$

$$\varepsilon |\nabla v_\varepsilon(x)| \rightarrow 0, \text{ as } \varepsilon \rightarrow 0. \tag{3.14}$$

Indeed let $x_0 \in \Omega \setminus S$. We may suppose $x_0 = 0$. As $x_0 \in \text{int}(\Omega)$ there exists $\rho > 0$ such that $B_{2\rho} = B(x_0, 2\rho) \subset \subset \Omega \setminus S$. Define

$$w_\varepsilon(z) = v_\varepsilon(\varepsilon^{1/2}z), \quad z \in \bar{B}_{\rho/\varepsilon^{1/2}}.$$

Then for ε small enough, w_ε satisfies $B_{\rho/\varepsilon^{1/2}}$,

$$\tilde{a}(z)\Delta w_\varepsilon(z) + \nabla_z \tilde{a}(z) \cdot \nabla_z w_\varepsilon(z) = \tilde{f}(z, w_\varepsilon(z)),$$

where $\tilde{a}(z) = a(\varepsilon^{1/2}z)$ and $\tilde{f}(z, w_\varepsilon(z)) = -f(\varepsilon^{1/2}z, w_\varepsilon(\varepsilon^{1/2}z))$.

For each $0 < \varepsilon < \varepsilon_0$ we have $B_{\rho/\varepsilon_0^{1/2}} \subset \subset B_{\rho/\varepsilon^{1/2}}$. As $\{v_\varepsilon\}_{0 < \varepsilon \leq \varepsilon_0}$ is continuous and uniformly bounded in ε , it follows that $\{w_\varepsilon\}_{0 < \varepsilon \leq \varepsilon_0}$ is also continuous and uniformly bounded in $B_{\rho/\varepsilon_0^{1/2}}$. In addition, $\tilde{a}(z), \nabla_z \tilde{a}(z)$ and \tilde{f} are uniformly bounded in $B_{\rho/\varepsilon_0^{1/2}}$, due to the hypotheses on a and f . Therefore by Corollary (6.3) in [8], $\exists C > 0$, independent of w_ε , so that $|\nabla_z w_\varepsilon(z)| \leq C, \forall z \in B_{\rho/2\varepsilon_0^{1/2}}$. But

$$|\nabla_z w_\varepsilon(z)| = |\nabla_z w_\varepsilon(x\varepsilon^{-1/2})| = \varepsilon^{1/2} |\nabla_x v_\varepsilon(x)| \leq C,$$

$\forall x \in B_{\rho/2}$. Then $\varepsilon |\nabla v_\varepsilon(x_0)| \rightarrow 0, \text{ as } \varepsilon \rightarrow 0$.

It is well known (see [12], for instance) that there exists a constant $C > 0$ (independent of ε) so that

$$\varepsilon |\nabla v_\varepsilon| \leq C, \quad \forall x \in \overline{\Omega}. \tag{3.15}$$

In order to show that $f(x, v_0(x)) = 0$ on $x \in V \setminus S$ we argue by contradiction and suppose that there exists $x_0 \in V \setminus S$ such that $f(x_0, \beta(x_0)) > 0$, for instance. The continuity of f and β implies the existence of $\delta > 0$ so that $f(x, \beta(x)) > 0 \quad \forall x \in B(x_0, \delta)$.

By integrating the first equation in (1.1) on $B(x_0, \delta)$ and using the Divergence Theorem we obtain

$$\varepsilon \int_{\partial B(x_0, \delta)} a(x) \nabla v_\varepsilon \cdot \hat{n}_B \, d\sigma = - \int_{B(x_0, \delta)} f(x, v_\varepsilon) \, dx.$$

where \hat{n}_B is the outward vector normal unitary at $B(x_0, \delta)$.

Taking a subsequence, if necessary, then taking the limit as $\varepsilon \rightarrow 0$, using (3.14) and (3.15) yield $\int_{B(x_0, \delta)} f(x, \beta(x)) \, dx = 0$, which amounts to a contradiction.

In the same way, taking a convenient neighborhood in $(\partial V \cap \partial\Omega) \setminus \Sigma$, it can be shown that $g(x, v_0(x)) = 0$ on $(\partial V \cap \partial\Omega) \setminus \Sigma$.

It remains to show that $\Phi_\varepsilon \rightarrow 0$, as $\varepsilon \rightarrow 0$, where Φ_ε is given in (3.2).

To that end it suffices to show that

$$\varepsilon \int_{K_l} |\nabla v_\varepsilon|^2 \, d\sigma \xrightarrow{\varepsilon \rightarrow 0} 0 \quad (l = \alpha, \beta) \tag{3.16}$$

and

$$\varepsilon \int_V |\nabla v_\varepsilon|^2 \, dx \xrightarrow{\varepsilon \rightarrow 0} 0. \tag{3.17}$$

Let us first show (3.17). Multiplying equation (1.1) by v_ε and integrating by parts in V we obtain for some $C > 0$,

$$\begin{aligned} \varepsilon \int_V |\nabla v_\varepsilon|^2 \, dx \leq C & \left[\int_V |v_\varepsilon| |f(x, v_\varepsilon)| \, dx + \int_{\partial V \cap \partial\Omega} |v_\varepsilon| |g(x, v_\varepsilon)| \, d\sigma \right. \\ & \left. + \varepsilon \int_{K_\alpha \cup K_\beta} |v_\varepsilon| |\nabla v_\varepsilon| \, d\sigma \right]. \end{aligned}$$

Since by hypothesis $\{v_\varepsilon\}_{0 < \varepsilon \leq \varepsilon_0}$ is uniformly bounded in $\overline{\Omega}$ and f and g are continuous, it follows that $\{f(x, v_\varepsilon)\}_{0 < \varepsilon < \varepsilon_0}, \{g(x, v_\varepsilon)\}_{0 < \varepsilon < \varepsilon_0}$ are uniformly bounded in $\overline{\Omega}$.

In addition $v_\varepsilon \xrightarrow{\varepsilon \rightarrow 0} v_0$ a.e in V and on $\partial V \cap \partial\Omega$. Thus, $f(x, v_\varepsilon) \xrightarrow{\varepsilon \rightarrow 0} f(x, v_0) = 0$, $g(x, v_\varepsilon) \xrightarrow{\varepsilon \rightarrow 0} g(x, v_0) = 0$ a.e in V and on $\partial V \cap \partial\Omega$, respectively. In this way utilizing (3.14) and (3.15) along with the Bounded Convergence Theorem we obtain (3.17).

Let us now show (3.16) when $l = \alpha$, the other case being alike.

Recall that $W = \{x \in \mathbb{R}^n : d(x) = \text{dist}(x, H) \leq \delta\}$.

Then d is Lipschitz continuous and, for $\delta > 0$ small enough, $|\nabla d| = 1$ a.e. in W . Recall also that $K_\alpha = d^{-1}\{\delta\} \cap \overline{\Omega}_\alpha$ and for each $t \in (0, \delta)$ the set

$$K^t \stackrel{\text{def}}{=} \{x \in V_\alpha : d(x) = t\}$$

is a smooth $(N-1)$ -dimensional surface.

Hence the co-area formula (see [10], [9]) along with (3.17) yield

$$\begin{aligned} \int_0^\delta \left\{ \varepsilon \int_{K^t} |\nabla v_\varepsilon|^2 d\sigma \right\} dt &= \varepsilon \int_{V_\alpha} |\nabla v_\varepsilon|^2 |\nabla d| dx = \varepsilon \int_{V_\alpha} |\nabla v_\varepsilon|^2 dx \\ &\leq \varepsilon \int_V |\nabla v_\varepsilon|^2 dx \xrightarrow{\varepsilon \rightarrow 0} 0. \end{aligned}$$

By consequence

$$\varepsilon \int_{K^t} |\nabla v_\varepsilon|^2 d\sigma \xrightarrow{\varepsilon \rightarrow 0} 0, \text{ a.e. in } (0, \delta),$$

and we may choose a suitable $\bar{t} \in (0, \delta)$ so that $K^{\bar{t}} = K_\alpha$, by taking δ smaller if necessary, and (3.16) is satisfied. □

4. Different diffusibility on Ω and $\partial\Omega$

In this section we present a corollary to Theorem 3.1 which applies to (1.1) when different diffusion coefficient scalings in Ω and $\partial\Omega$ are considered, namely,

$$\begin{cases} \varepsilon^2 \operatorname{div}(a(x)\nabla v_\varepsilon) + f(x, v_\varepsilon) = 0, & x \in \Omega \\ \varepsilon^2 a(x) \frac{\partial v_\varepsilon}{\partial \hat{n}} = \lambda_\varepsilon g(x, v_\varepsilon), & x \in \partial\Omega. \end{cases} \tag{4.1}$$

where Ω , a , f and g satisfy the hypotheses considered in the beginning.

Corollary 4.1. *Let $\{v_\varepsilon\}_{0 < \varepsilon \leq \varepsilon_0}$ be a family of solutions to (4.1), uniformly bounded in $\overline{\Omega}$ with respect to ε , which develops internal and superficial transition layer with interfaces S and Σ , in the sense of Definition 2.1. Then:*

- (i) $\int_{\alpha(x)}^{\beta(x)} f(x, \xi) d\xi = 0$ as long as $\lim_{\varepsilon \rightarrow 0} \lambda_\varepsilon = 0$
- (ii) $\int_{\alpha(x)}^{\beta(x)} g(x, \zeta) d\zeta = 0$ as long as $\lim_{\varepsilon \rightarrow 0} \lambda_\varepsilon = \infty$
- (iii) $\int_{\alpha(x)}^{\beta(x)} f(x, \xi) d\xi = \int_{\alpha(x)}^{\beta(x)} g(x, \zeta) d\zeta = 0$ as long as $\lim_{\varepsilon \rightarrow 0} \lambda_\varepsilon = k$, where $0 < k < \infty$.

Although we do not care here the same conclusions about α and β being zeros of f and g hold, i.e., in (i) it holds that α and β are zeros of f , in (ii) they are zeros of g and in (iii) they are zeros of f and g simultaneously, in suitable neighborhoods of the interface S .

The demonstration of each item can be achieved by following *ipsis literis* the proof of Theorem 3.1 and using the hypotheses on the scaling at the end.

The reason such scaling has been chosen relies on the fact that for each item above we do have an example of a family of solutions to (4.1) which realizes Definition 2.1.

Indeed $\lambda_\varepsilon = \sqrt{\varepsilon}$ for (i), $\lambda_\varepsilon = \varepsilon^{-1}$ for (ii) and $\lambda_\varepsilon = k > 0$ for (iii) are examples of scalings considered in [2], where existence of a family of solutions to (4.1) satisfying the hypotheses of Corollary 4.1 is proved.

5. Reaction-diffusion and advection

Reaction-diffusion problems with an advection (transport) term are also of interest as far as formation of internal layers is concerned. Let us consider the problem

$$\begin{cases} \varepsilon \operatorname{div}(a(x)\nabla v_\varepsilon) + \varepsilon \mathbf{b}(x) \cdot \nabla v_\varepsilon + f(x, v_\varepsilon) = 0, & x \in \Omega \\ \varepsilon a(x) \frac{\partial v_\varepsilon}{\partial \hat{n}} = g(x, v_\varepsilon), & x \in \partial\Omega, \end{cases} \quad (5.1)$$

where in addition to the hypotheses of the Introduction, \mathbf{b} is a smooth vector field on $\bar{\Omega}$. The advection term in (5.1) can be easily handled by using estimate (3.17). Indeed the only contribution due to the advection term in the proof of Theorem 3.1 is $\varepsilon \int_\Omega X \cdot \nabla v_\varepsilon \mathbf{b}(x) \cdot \nabla v_\varepsilon$. This term, except for a multiplicative constant, is bounded from above by $\varepsilon |\nabla v_\varepsilon|^2$, which by (3.17) approaches zero as $\varepsilon \rightarrow 0$.

Therefore Theorem 3.1 still holds true for (5.1).

Acknowledgements. This work is part of the second author doctoral thesis at Universidade Federal de São Carlos under the supervision of the first author.

References

- [1] G. Alberti, E. Bouchitté, and P. Seppecher, *Phase Transition with the Line-Tension Effect*, Arch.Rational Mech. Anal. **144** (1998), 1-46.
- [2] A.S. do Nascimento and R. J. de Moura, *On existence and non-existence of patterns in a reaction-diffusion equation with nonlinear Neumann boundary condition* (preprint).
- [3] A.S. do Nascimento, *Stable stationary solutions induced by spatial inhomogeneity via Γ -convergence*, Bulletin of the Brazilian Mathematical Society **29** No. 1 (1998), 75-97.
- [4] A.S. do Nascimento, *Stable transition layers in a semilinear diffusion equation with spatial inhomogeneities in N -dimensional domains*, J. Diff. Eqns. **190**, (2003), 16-38.
- [5] A.S. do Nascimento, *Internal transitions layers in a elliptic boundary value problem: a necessary condition*, Nonlinear Analysis: T., M. & A. **44** (2001), 487-497.
- [6] A.S. do Nascimento and J. Crema, *On the role of the equal-area condition in internal layer stationary solutions to a class of reaction-diffusion systems*, Electronic J. Diff. Eqns. **99** (2004), 1-13.
- [7] A.S. do Nascimento and J. Crema, *A geometric sufficient condition for existence of stable transition layers in a class of spatial heterogeneous diffusion equations*, Matemática Contemporânea, Fifth Workshop on Nonlinear Differential Equations, volume **27** (2004), 53-73.

- [8] D. Gilbarg and N.S. Trudinger, *Elliptic Partial Differential Equations of Second Order*, A Series of Comp. Stud. in Math, **224**, Springer-Verlag, 1983.
- [9] L. C. Evans, *Partial Differential Equations*, American Mathematical Society, Providence, Rhode Island, 1998.
- [10] L. C. Evans and R. F. Gariepy, *Measure Theory and Fine Properties of Functions*, CRC Press, Boca Raton, 1992.
- [11] J. Arrieta, N. Cónsul and A. Rodríguez-Bernal, *Stable boundary layers in a diffusion problem with nonlinear reaction at the boundary* Z. Angew. Math. Phys. **55** No. 1 (2004), 1-14.
- [12] O. A. Ladyzhenskaya and N. N. Ural'tseva, *Linear and Quasilinear Elliptic Equations*, Academic Press, New York, 1968.

Arnaldo Simal do Nascimento and Renato José de Moura
Universidade Federal de S. Carlos, D.M.
13565-905 – São Carlos, S.P.
Brazil

Some Recent Results Regarding Symmetry and Symmetry-breaking Properties of Optimal Composite Membranes

Renato H.L. Pedrosa

Dedicated to Djairo G. de Figueiredo on the occasion of his 70th birthday

Keywords. Composite membranes, minimizing eigenvalues, symmetry, symmetry-breaking.

1. Composite membranes: motivation and some preliminary results

The study of vibrating membranes is a classical subject in mathematical physics, and is at the origin of many important developments in the theory of partial differential equations. Among the most studied aspects of the subject is the relationship between the geometry of the membrane and properties of the frequencies of its natural modes of vibration, given by the eigenvalues of 2nd order elliptic operators, in particular of the Laplacian. Classic references on the subject are the books by Lord Rayleigh ([19]), by Courant and Hilbert ([10]) and by Pólya and Szegő ([18]). A general source for problems on eigenvalues and membranes is [1].

The purpose of this note is to present a survey of recent results on symmetry properties (and lack of them) of domains in \mathbb{R}^n which have minimal first Dirichlet eigenvalue, when the domain represents a vibrating membrane composed by materials of two distinct densities (*a composite membrane*). We discuss both the bounded and the 1-periodic cases. There are partial symmetry and symmetry-breaking results. The main technique for the symmetry results is that of rearrangements of functions. For the symmetry-breaking results, one uses eigenvalue estimates which follow from elliptic theory and classical orthogonal polynomial theory (Jacobi polynomials). We present various results and include proofs for the 1-periodic case. The main sources for the results presented below are [4], [7] and [17]. We end with a list of open problems.

The *composite membrane eigenvalue problem, with Dirichlet boundary condition*, is

$$(*)_{\Omega, \alpha, D} \begin{cases} -\Delta u + \alpha \chi_D u = \lambda u & \text{in } \Omega \\ u = 0 & \text{in } \partial\Omega \end{cases},$$

where Δ is the Laplacian, $\Omega \subset \mathbb{R}^n$ is a bounded domain, $D \subset \Omega$ is closed of positive measure and $\alpha > 0$ a specified real constant (χ_D is the characteristic function of D).

To see how this relates to a vibrating membrane made of materials of distinct mass densities, recall that a membrane, with fixed contour and made of a material of varying mass density distribution, is modelled by a domain $\Omega \subset \mathbb{R}^n$ and by the wave equation, which, upon separation of the space and time variables, leads us to the Dirichlet eigenvalue problem:

$$(*)_{\Omega, \rho} \begin{cases} -\Delta u = \lambda \rho u & \text{in } \Omega \\ u = 0 & \text{in } \partial\Omega \end{cases},$$

where $\rho > 0$ is the mass distribution function. The membrane has a rest shape given by Ω , the graph of u represents the membrane off the resting position for the natural vibrating mode and λ is the square of the frequency of vibration.

One may also consider the 1-periodic case, i.e., $\Omega = \mathbb{R} \times \Omega'$, with $\Omega' \subset \mathbb{R}^{n-1}$ bounded, and restrict the analysis to mass distribution and solutions which are periodic in the first variable, for some fixed value of period. All the basic discussion below extends to that case. A natural way of looking at the periodic situation is to consider the domain as the submanifold $S^1 \times \Omega' \subset \mathbb{R}^{n+1}$, where S^1 is the circle of radius $2\pi/T$ (T is the period). Adding the boundary, we again obtain a compact manifold as in the case of a bounded domain and $\partial\Omega$ is given, then, by the compact set $S^1 \times \partial\Omega'$. We will call $S^1 \times \Omega'$ the *compact model* for Ω , and denote it also by Ω .

In what follows, every time, in the 1-periodic case, that we consider integrals over Ω , including those furnishing volumes, we will be doing calculations in the compact model.

Assume that Ω is sufficiently regular (e.g. has finite perimeter, which, in the periodic case, means that the compact model has finite perimeter) and take ρ in $L^\infty(\Omega)$. The spectral theorem gives a positive denumerable sequence of eigenvalues

$$(0 <) \lambda_1 < \lambda_2 \leq \lambda_3 \leq \dots$$

for problem $(*)_{\Omega, \rho}$, and associated set of eigenfunctions u_i , which may be taken mutually orthogonal and normalized, with respect to the (ρ -weighted) L^2 -inner product in Ω . It is a complete set of functions, in the sense that any sufficiently regular function $v : \Omega \rightarrow \mathbb{R}$ such that $v = 0$ at $\partial\Omega$ may be written as the (Fourier) series

$$v = \sum_{i=1}^{\infty} \langle v, u_i \rangle u_i.$$

The first eigenvalue, λ_1 , is called the fundamental frequency or pitch of the membrane. It is simple (1-dimensional eigenspace). In the 1-periodic case, all the eigenfunctions are periodic for the given period.

Lord Rayleigh studied the values of λ_1 as a function of $\Omega \subset \mathbb{R}^2$, for constant ρ , once the area of Ω is fixed. He observed that λ_1 for the round disk $D(r) = \{(x, y) \in \mathbb{R}^2 : x^2 + y^2 < r^2\}$ of radius r had, among all domains for which he could calculate λ_1 explicitly, the least value possible. He conjectured that as a property characterizing the round disk. It is worth quoting his exact phrasing of the problem ([19], Vol. 1, p. 339):

We have seen that the gravest tone of a membrane, whose boundary is approximately circular, is nearly the same as that of a mechanically similar membrane in the form of a circle of the same mean radius or area. If the area of a membrane be given, there must evidently be some form of the boundary for which the pitch (of the principal tone) is the gravest possible, and this can be no other than the circle.

Rayleigh's conjecture was proved true in the mid 1920's by Faber and Krahn, independently, now known as the Faber–Krahn inequality, a prototypical result on the symmetry of optimal membranes:

Theorem 1 (Faber–Krahn inequality). *Consider ρ constant and fixed. For all bounded domains $\Omega \subset \mathbb{R}^n$ of a given volume $v > 0$, one has*

$$\lambda_1(\Omega) \geq \lambda_1(B(r)),$$

where $B(r)$ is the round ball of radius r (centered at the origin), with r such that its volume is v . If equality occurs, Ω must be a round ball (maybe centered at some other point).

The less studied case of variable mass distribution also raises interesting variational problems for the eigenvalues. The one which leads to the composite membrane problem is when one considers Ω given, fixes the total mass

$$M = \int_{\Omega} \rho \, dx$$

and asks which mass distribution ρ satisfying these conditions gives the least λ_1 possible. Usually, one also assumes the (natural) restriction that the density function is bounded by two positive values, i.e., $0 < \rho_1 \leq \rho \leq \rho_2 < \infty$.

Various authors have considered this problem, starting with the early work on the 1-dimensional case by Krein [15], then Cox and McLaughlin [11], Cox [12] and, recently, Chanillo *et al* [7, 8], Blank [5], Assunção *et al* [4] and the author [17].

The first (and somewhat surprising) result we mention is that the distribution function ρ which minimizes λ_1 becomes discontinuous. Explicitly, one has:

Theorem 2. *Let Ω , $0 < \rho_1 < \rho_2 < \infty$ and $M > 0$ be given. The distribution function ρ which minimizes λ_1 in problem $(*)_{\Omega,\rho}$, for fixed total mass M and $0 < \rho_1 \leq \rho \leq \rho_2 < \infty$ is given by*

$$\rho = \rho_1 \chi_D + \rho_2 \chi_{D^c},$$

where D is a (closed) subset of Ω and D^c its complement. More over, if u is the first eigenfunction associated to λ_1 for this configuration, D is a sublevel set of u , i.e.,

$$D = \{x \in \Omega : u(x) \leq c\},$$

for some $c > 0$.

The possible values of M are restricted to the interval $[\rho_1|\Omega|, \rho_2|\Omega|]$ ($|\cdot|$ is the measure of a set). This result is due to Krein ([15]) in the line and to Chanillo *et al* ([7]) in higher dimension, both in the bounded domain case. The proof for the 1-periodic case follows along the same lines.

The resulting optimal membrane is what is called a *composite membrane*: it is made of two materials, distinguished by their mass densities. So, it is possible to turn this situation around and consider vibrating membranes having this type of distribution of mass and the associated variational problem for its first eigenvalue. This eigenvalue problem is the one given by problem $(*)_{\Omega,\alpha,D}$ at the beginning of this section, for a certain range of values of α (see below). In general, one does not put any restriction on the configuration, like the one that says that the lower density part is attached to the boundary. This comes up only in the minimizing situation.

To understand further how the variational problems for the first eigenvalues of both equations relate to each other, observe that, once Ω is given, the condition of fixed total mass, in the presence of the bounds on ρ , becomes a condition on fixed volume of D , given by

$$|D| = \frac{\rho_2|\Omega| - M}{\rho_2 - \rho_1}. \tag{1}$$

If one lets D vary among subsets of Ω of a given volume, then the configuration which provides the minimal first eigenvalue for problem $(*)_{\Omega,\alpha,D}$ is the same as the one given by Theorem 2, with volume given by (1). The constant $\alpha > 0$ is related to the values of ρ_1, ρ_2 and the volume of D (or the total mass), up to a maximal value of α , which occurs when α is equal to the minimal eigenvalue, given Ω and the volume of D . We will denote this special value of α by $\bar{\alpha}_{\Omega,\delta}$, where $\delta = |D|/|\Omega|$. The physically relevant situation is when α is less than the minimal eigenvalue, i.e., when the minimization problems for variable density and composite membranes are strictly equivalent (for details, see [7]).

From now on, we will consider only the problem of minimizing the first eigenvalue of composite membranes. Denote the first eigenvalue of $(*)_{\Omega,\alpha,D}$ by $\lambda_{\Omega,\alpha}(D)$.

Variational problem for $\lambda_{\Omega,\alpha}(D)$: *fix Ω and $\alpha > 0$. For each $\delta \in (0, 1)$, minimize $\lambda_{\Omega,\alpha}(D)$ among all $D \subset \Omega$ such that $|D| = \delta|\Omega|$.*

We will say that the pair (u, D) is an *optimal pair for α and δ in Ω* if $|D|/|\Omega| = \delta$, u is the first eigenfunction for problem $(*)_{\Omega, \alpha, D}$ and the first eigenvalue realizes the minimum for the volume considered. The resulting configuration (Ω, D) is called an (α, δ) -*optimal composite membrane in Ω* or just an *optimal composite membrane*.

Before we move on to the symmetry and symmetry-breaking properties of optimal membranes, we state existence and regularity results of optimal configurations. Since D is a sublevel set of the first eigenfunction u in the optimal situation, the regularity of u and its properties are relevant issues. Observe that one cannot expect u to be even C^2 , since Δu is discontinuous.

The main existence and regularity result, in this form due to Chanillo *et al* [7] (but see also [15, 11, 12]), is:

Theorem 3. *For any $\alpha > 0$ and $\delta \in [0, 1]$, there exists an optimal pair (u, D) for α, δ in Ω . Moreover, it satisfies:*

1. $u \in C^{1, \sigma}(\Omega) \cap H^2(\Omega) \cap C^\gamma(\overline{\Omega})$ for some $\gamma > 0$ and every $\sigma < 1$.
2. Let c be such that $D = \{u \leq c\}$; every level set $u = s$, $s \geq 0$, has measure zero (except possibly for a special case of α and for $s = c$).

The special case mentioned occurs when $\alpha = \overline{\alpha}_{\Omega, \delta}$, the critical value mentioned above. Recently, Chanillo and Kenig [9] have improved the regularity of u to $C^{1,1}(\Omega)$ in 1. above.

2. Symmetry and symmetry-breaking for optimal bounded composite membranes

In this section we restrict ourselves to the case where Ω is bounded. The first symmetry result we have is as follows. One says that a set $A \subset \mathbb{R}^n$ is convex with respect to a hyperplane $\pi \subset \mathbb{R}^n$ if the intersection of A with every line perpendicular to π is a segment.

Theorem 4 (Symmetry with convexity). *If Ω is bounded, symmetric and convex with respect to a hyperplane $\pi \subset \mathbb{R}^n$, then an optimal pair (u, D) is symmetric and D^c is convex with respect to π . As a special case, if Ω is a round ball, solutions are radially symmetric (D is an annulus attached to the boundary of the disk and u is radial).*

The result for the ball was conjectured by Krein [15] in two dimensions. This theorem is due to Chanillo *et al* [7] (an incomplete proof is found in [12]). The proof follows from Steiner symmetrization plus a fine argument regarding the equality case.

They also proved that the convexity property is essential for full symmetry, by showing that if Ω is the 2-dimensional annulus, depending on the geometry (ratio between the two radii) and on the parameters (α and δ), the minimizing configuration may fail to be circularly symmetric. The result was extended to $n \geq 3$ by the author [17], and it reads as follows:

Theorem 5 (Symmetry-breaking for n -dimensional annuli). *Let*

$$\Omega = \{x \in \mathbb{R}^n : a < \|x\| < a + 1\}.$$

For any $\alpha, \delta > 0$ there is a constant $a_{n,\alpha,\delta} > 0$, depending only on n, α and δ , such that, if $a \geq a_{n,\alpha,\delta}$, then, optimal pairs (u, D) for α and δ in Ω are not $O(n)$ -symmetric.

The proof for $n \geq 3$ is similar to the one for $n = 2$, involving eigenvalue estimates. For $n \geq 3$, one substitutes the trigonometric testing functions used for $n = 2$ in [7] by some special cases of the classical Jacobi polynomials. For the 3-dimensional case, these are the classical Legendre polynomials with a changed variable. In the next section, we present the general argument for the 1-periodic case, which is essentially the same (but even simpler) as the one in this case.

In [7], they also construct 2-dimensional dumbbell configurations where the symmetry is broken due to the nonconvexity of the domain.

One interesting aspect of the numerical examples presented in [7] which give the non-circular optimal configurations for the annulus is that, apparently, one still gets line-symmetry (for some line through the center of the annulus). This motivated the author to find out if this was a property of annular minimizers. In fact, the result below includes that result, and extends it to more general domains, those which are symmetric under an orthogonal subgroup of the isometries of \mathbb{R}^n .

Observe that in the 2-dimensional annular case, the annulus is $O(2)$ -symmetric and $O(1)(= \mathbb{Z}_2)$ -symmetry corresponds to a line reflection.

Let $O(l)$ be the l -orthogonal group acting linearly on \mathbb{R}^l . Let $k < n$. $\Omega \subset \mathbb{R}^n$ is invariant under $O(k+1)$ if there is subgroup $H \subset O(n)$, isomorphic to $O(k+1)$ and acting linearly on \mathbb{R}^n , taking Ω to itself. The optimal pair (u, D) is $O(k)$ -symmetric if D is invariant under K and if $u(gx) = u(x)$ for all elements $g \in K$, where $K \subset H$ is of type $O(k)$. The following result is from [17].

Theorem 6 (Partial spherical symmetry). *Let $\Omega \subset \mathbb{R}^n$ be a bounded domain which is invariant under $O(k+1)$, $k < n$. Then, there is an optimal pair (u, D) which is $O(k)$ -symmetric. Moreover,*

1. *In case $\alpha \leq \bar{\alpha}_{\Omega,\delta}$, every optimal pair is $O(k)$ -symmetric.*
2. *In all cases, the intersection of D (and of D^c) with a k -sphere which is an orbit of $O(k+1)$ is always a geodesic disk in the sphere.*

Thus, together, Theorems 5 and 6 put the situation for annuli in \mathbb{R}^n in clear terms: the best one can hope for minimizers, namely, $O(n-1)$ -symmetry, actually occurs, at least in the physically relevant situation.

Remarks. 1. It is sufficient that merely a translation of Ω is $O(k+1)$ -invariant.

Then, the subgroups may be taken to act after such translation.

2. The proof requires extending the usual estimates involving the Dirichlet integral to some general partial rearrangement setting.
3. The restriction involving the range of α does seem artificial, but at this point the author does not know how to avoid it. The difficulty appears in

the analysis of the equality case, when one has a configuration (u, D) which gives the minimal eigenvalue, and one tries to show that it must be $O(k)$ -symmetric. This case has a more complicated analytical structure than the one considered in [7]. But we note that, as mentioned above, $\alpha < \bar{\alpha}_{\Omega, \delta}$ is the physically relevant situation of the actual two-materials membrane.

4. For the equality case in rearrangement problems, see [14] in general, [6] for a sharp result in the spherically decreasing symmetrization case and [17] for the partial spherical symmetrization case used in the proof of Theorem 6.

3. Symmetry and symmetry-breaking for optimal 1-periodic composite membranes

We now present some new results concerning the 1-periodic case. The symmetry-breaking phenomenon for this case was treated by Assunção, Bronzi and Chumakova [4] in the 2-dimensional case, i.e., when $\Omega = \mathbb{R} \times (0, 1)$, and was the result of a NSF Research Experience for Undergraduates (REU) Institute held at Unicamp (Brazil) in July of 2004, under the supervision of the author. We will present a simple reflection symmetry result and the symmetry-breaking case in all dimensions.

So, we consider a domain $\Omega \subset \mathbb{R}^n$ given by

$$\Omega = \{(x, y) \in \mathbb{R}^n : x \in \mathbb{R}, y \in \Omega' \subset \mathbb{R}^{n-1}\},$$

where Ω' is a (sufficiently regular) bounded domain. We will restrict the configurations and functions involved to periodic ones in the x direction. In other words, all the eigenfunctions, test functions and D considered will be taken of some given period T in the x variable.

Even though Ω is not bounded, once one fixes the period T , it is possible to consider the compact model $S^1 \times \Omega' \subset \mathbb{R}^{n+1}$, where S^1 is the circle in \mathbb{R}^2 of radius $2\pi/T$ as the domain Ω , as mentioned before. In case $n = 2$, when $\Omega' = (0, 1)$, we get the piece of the cylinder (see Figure 1 below):

$$x^2 + (z - R)^2 = R^2, \quad 0 < y < 1, \quad \text{where } R = \frac{T}{2\pi}.$$

All the general properties of minimizers given for the bounded case apply here, including existence and regularity and the symmetry results when applied to Ω' . For example, if Ω' is convex and symmetric with respect to some hyperplane $\pi' \subset \mathbb{R}^{n-1}$, then minimizers are symmetric with respect to $\pi = \mathbb{R} \times \pi'$, analogously if Ω' is $O(k + 1)$ -invariant, and so on.

A simple but nontrivial partial symmetry result is that there must be a reflectional symmetry with respect to a section.

Theorem 7 (Reflectional symmetry in the periodic case). *Let $\Omega = \mathbb{R} \times \Omega'$, $\alpha > 0$ and $\delta \in (0, 1)$ be given. There is a minimizing pair (u, D) for α and δ in Ω which is symmetric with respect to the section $\{0\} \times \Omega'$ (or, equivalently, to the hyperplane $\pi = \{(x, y) \in \mathbb{R} \times \mathbb{R}^{n-1} : x = 0\}$). Moreover,*

1. If $\alpha \leq \bar{\alpha}_{\Omega, \delta}$, then all minimizing pairs are symmetric with respect to the section $\{0\} \times \Omega'$ (up to an x -translation).
2. In all cases, the intersection of every line $L_{y_0} = \{(x, y) \in \Omega : y = y_0\}$ with D (and with D^c) is a (periodic) disjoint set of segments such that, if one looks at the compact model $S^1 \times \Omega'$, $D \cap L_{y_0}$ is a circle segment, possibly empty (and its complement is $D^c \cap L_{y_0}$).

Proof. The proof is analogous to the proof of Theorem 6 above as given in [17]. One performs Steiner rearrangement on the first eigenfunction of some minimizing pair in the x -direction. In fact, it is given by a partial rearrangement of $O(2)$ -type, as in Theorem 6, since one has an $O(2)$ -action on $S^1 \times \Omega'$. In other words, we have what is known as “circular rearrangement” in the literature (see [14]), getting the basic estimates for the Dirichlet integral. Since the first eigenvalue is given by the minimum among admissible functions of the following Rayleigh’s quotient,

$$\mathcal{R}(u) = \frac{\int_{\Omega} \|\nabla u\|^2 + \alpha \int_D u^2}{\int_{\Omega} u^2},$$

the first part follows from the proof of Theorem 4 in [7]. The equality case, when $\alpha \leq \bar{\alpha}_{\Omega, \delta}$, follows along the same lines as the proof of Theorem 6 in [17]. \square

One may ask if this partial symmetry result is optimal, in the sense that it may be just a weak version of the stronger full translational symmetry result (or, equivalently, of the $O(2)$ -symmetry result in the compact model). The next theorem shows that, in general, the reflectional symmetry is the best one can hope for.

Theorem 8 (Symmetry-breaking for 1-periodic membranes). *For each $\alpha > 0$ and $\delta \in (0, 1)$, there is a constant $T_{\alpha, \delta} > 0$, depending only on α and δ , such that, if $T > T_{\alpha, \delta}$, a minimizing pair (u, D) in Ω with volume $|D| = \delta|\Omega|$ is not invariant under x -translations (or, equivalently, is not invariant under $O(2)$ in the compact model).*

Proof. The proof follows closely the one in [7] for the 2-dimensional annulus, as adapted to the 2-dimensional periodic case in [4]. We will only mention the few modifications needed. Instead of working on Ω with periodic data and functions, we will fix $T > 0$, let Ω_T be the fundamental domain

$$\Omega_T = \{(x, y) \in \mathbb{R}^n : x \in [0, T], y \in \Omega'\} = [0, T] \times \Omega'$$

and consider geometric data and functions which coincide at $x = 0$ and $x = T$. Observe that the relevant boundary of Ω_T will be given by $[0, T] \times \partial\Omega'$. The points belonging to the sections $\{0\} \times \Omega'$ and $\{T\} \times \Omega'$ are thought of, in fact, as interior points.

A $D \subset \Omega_T$ which is x -independent (i.e., for which the periodic extension in the x direction is invariant under x -translations) may be written in the form

$$D = \{(x, y) \in \Omega_T : y \in D_1 \subset \Omega'\}.$$

The (periodic) composite membrane problem takes the form

$$(*)_{\Omega',\alpha,T,D} \begin{cases} -\Delta u + \alpha \chi_D u &= \sigma u & \text{in } \Omega_T \\ u(x,y) &= 0 & \text{if } y \in \partial\Omega' \\ u(0,y) &= u(T,y) & \text{for } y \in \Omega' \end{cases} .$$

Let u be the first eigenfunction for D , with eigenvalue σ . For T sufficiently large (depending on α and $\delta = |D|/|\Omega_T|$), we will construct a comparison domain \tilde{D} and a function \tilde{u} such that

$$\frac{\int_{\Omega_T} \|\nabla \tilde{u}\|^2 + \alpha \int_{\tilde{D}} \tilde{u}^2}{\int_{\Omega_T} \tilde{u}^2} < \sigma. \tag{2}$$

Since the infimum of the Rayleigh quotient (the left-hand side of (2)) gives the first eigenvalue for problem $(*)_{\Omega',\alpha,T,\tilde{D}}$, it would follow from (2) that (u, D) cannot be an optimal pair.

First, pick $N = N(\delta)$ with $\delta < 1 - 1/2N$ and consider the piece of Ω_T given by

$$E_N = \Omega_T \cap \{(x, y) : 0 \leq x \leq T/2N\}.$$

Next, let \tilde{u} be the first Dirichlet eigenfunction of the Laplacian on E_N ,

$$(*)_{\Omega',T,N} \begin{cases} -\Delta \tilde{u} &= \lambda_1(E_N) & \text{in } E_N, \\ \tilde{u} &= 0 & \text{in } \partial E_N \end{cases} ,$$

extended to zero on $\Omega_T \setminus E_N$, and $\lambda_1(E_N)$ be the first eigenvalue. In this case, ∂E_N is the full boundary of the set E_N .

Let \tilde{D} be any (closed) subset of $\Omega_T \setminus E_N$ with $|\tilde{D}| = |D|$, which exists by the choice of N . See Figure 1 for a 2-dimensional representation, taken from [4] (E_+ in this picture is our E_N). Since $\text{supp } \tilde{u} \cap \tilde{D} = \emptyset$, we have

$$\frac{\int_{\Omega_T} |\nabla \tilde{u}|^2 + \alpha \int_{\Omega_T} \chi_{\tilde{D}} \tilde{u}^2}{\int_{\Omega_T} \tilde{u}^2} = \frac{\int_{E_N} |\nabla \tilde{u}|^2}{\int_{E_N} \tilde{u}^2} = \lambda_1(E_N),$$

so (2) is equivalent to

$$\lambda_1(E_N) < \sigma. \tag{3}$$

In order to prove (3), we will use a third eigenvalue problem, as in [7], which is intermediate between $(*)_{\Omega',\alpha,D,T}$ and $(*)_{\Omega',T,N}$, as follows. Restrict problem $(*)_{\Omega',\alpha,D,T}$ to functions of type

$$v(x, y) = h(y) \sin\left(\frac{2N\pi x}{T}\right), \tag{4}$$

and define v to be the lowest eigenfunction of this restricted composite membrane problem, which we denote by $(*)_{\Omega',\alpha,D,T}$, letting τ be the associated first eigenvalue. This restricted problem is equivalent to the following eigenvalue problem in Ω' :

$$(*)''_{\Omega',\alpha,D_1,T,N} \begin{cases} -\Delta h(y) + \left[\left(\frac{2N\pi}{T}\right)^2 + \alpha \chi_{D_1}(y)\right] h(y) &= \tau h(y) & \text{for } y \in \Omega' \\ h &= 0 & \text{for } y \in \partial\Omega' \end{cases}$$

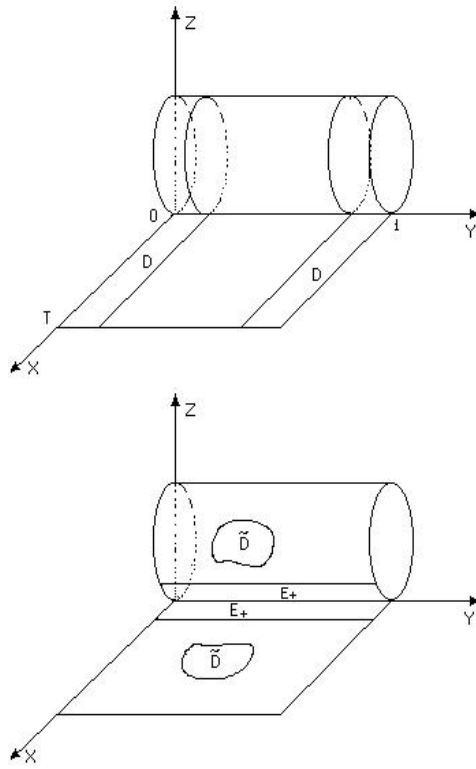

FIGURE 1. Periodic case: symmetric D and test domain \tilde{D}

for h . Thus, h in (4) will be the first eigenfunction of this last problem, and the eigenvalue τ is characterized by

$$\tau = \inf_{g \in F} \frac{\int_{\Omega'} \left\{ \|\nabla g\|^2 + \left[\alpha \chi_{D_1} + \left(\frac{2N\pi}{T} \right)^2 \right] g^2 \right\}}{\int_{\Omega'} g^2}, \tag{5}$$

where F may be taken as $C_0^1(\Omega') \setminus \{0\}$.

As usual, h does not change sign on Ω' , so that we may assume $h \geq 0$ and that h is normalized. We will use u and v to obtain the necessary eigenvalue comparison (3). The following lemma provide the needed estimates. The proofs are essentially the same as those for the analogous results in [7].

Lemma 1. *Let $\Omega' \subset \mathbb{R}^{n-1}$, $T > 0$, $\alpha > 0$ and $\delta \in (0, 1)$ be given. Let D radial, N , \tilde{D} , σ , τ and v be as above.*

1. One has the following estimate for the gap between τ and σ :

$$\tau - \sigma \leq \left(\frac{2N\pi}{T}\right)^2. \tag{6}$$

2. Assume $T > 1$. There is a constant $C = C_{\Omega', \alpha, \delta} > 0$, independent of T , such that

$$\int_D v^2 \geq C \int_{\Omega_T} v^2.$$

We can now complete the proof of Theorem 8, repeating the argument in [7]. First, we have

$$\tau = \frac{\int_{\Omega_T} \|\nabla v\|^2}{\int_{\Omega_T} v^2} + \frac{\alpha \int_{\Omega_T} \chi_D v^2}{\int_{\Omega_T} v^2}. \tag{7}$$

Also, $v(x, y) = h(y) \sin(\frac{2Nx\pi}{T})$, thus v vanishes on the sections $x = 0$ and $x = T/2N$ and v and $\|\nabla v\|$ are periodic in x with period $T/2N$. So, we may replace Ω_T by E_N in the first quotient as the domain of integration. Also, it makes sense to use v as a test function in the Rayleigh quotient for the Dirichlet Laplacian on E_N , so that we get

$$\frac{\int_{\Omega_T} \|\nabla v\|^2}{\int_{\Omega_T} v^2} = \frac{\int_{E_N} \|\nabla v\|^2}{\int_{E_N} v^2} \geq \lambda_1(E_N). \tag{8}$$

Combining these remarks, (7) and (8) with Lemma 1.(2), we obtain

$$\tau \geq \lambda_1(E_N) + \alpha C. \tag{9}$$

From (9) and Lemma 1.(1), it follows that

$$\sigma \geq \tau - \left(\frac{2N\pi}{T}\right)^2 \geq \lambda_1(E_N) + \alpha C - \left(\frac{2N\pi}{T}\right)^2,$$

implying that, if T is such that $T > 2N\pi/\sqrt{\alpha C} = T_{\alpha, \delta}$, we get estimate (3), finishing up the proof. □

4. Final comments and open problems

Besides the open cases for the larger values of α in Theorems 6 and 7, we present below a few problems which may interest the reader.

Regarding the regularity of an optimal pair, we mention the following result on the regularity of the free boundary $S = \partial D \cap \Omega$, proved in [7, 8]: *For sufficiently small α , if Ω is a convex domain with C^2 boundary and (u, D) is an optimal pair, then S is an analytic hypersurface and D^c is convex.*

Recently, Chanillo and Kenig [9] improved this result in dimension 2: if $\Omega \subset \mathbb{R}^2$ is convex with C^2 boundary, the free boundary S in the optimal case is a convex analytic curve, for all $\alpha < \bar{\alpha}_{\Omega, \delta}$, i.e., in the physically relevant range for α . Also, they proved that if the domain has a line of symmetry, then the free boundaries for

optimal configurations are rectifiable. Along different lines, Blank [5] has obtained results concerning the local structure of singular points for all dimensions, and quite explicitly in dimension 2. Still, optimal and higher dimensional analogues of these results are lacking:

Problem 1: Get optimal regularity properties for S in general. Is it true that S is an analytic hypersurface except for a closed subset of positive (≥ 1) Hausdorff codimension? What is the structure of singular points?

The property that $S = \partial D \cap \Omega$ is a level set of u , in the optimal case, is, in fact, a property of sufficiently regular critical points for the variational problem, i.e., if (u, D) is a critical point for variations of $\lambda_1(D)$ as a function of D , and D has finite perimeter, then D is a sublevel set of u and $S = u^{-1}(c)$ for some $c > 0$ (result by S. Chanillo and the author, ongoing research). This raises the question about properties of *stable* composite membranes, i.e., those critical points which are local minima. For example,

Problem 2: Can one characterize the annuli as the only stable configuration for D in the case Ω is a round ball? What extra properties do stable configurations have? How about the Morse theory of critical points, and bifurcations?

If one looks in detail at the symmetry-breaking results for annuli and 1-periodic membranes, it is clear that the estimates for a and T , respectively, are far from sharp. Also, it is not clear if the transition between the symmetric and non-symmetric configurations occur only once as a (or T) increases.

Problem 3: Can one obtain a sharp result concerning the symmetry-breaking properties of annuli and of 1-periodic membranes (in this case, maybe the 2-dimensional case is an easier task)? I.e., does the transition occur only once; if so, what is its value or, at least, how to better the estimates given by the above theorems?

One may try to extend many classical results which are known for the constant density membrane, like the Payne-Polya-Weinberger problem. PPW asked which form of the membrane maximizes the ratio λ_2/λ_1 , and conjectured that it should be the round ball (in this case the volume constraint is unnecessary). Ashbaugh and Benguria proved it true in 1992 ([2]). One may ask, for example,

Problem 4: If Ω is the round ball, given $\delta \in (0, 1)$, what is the configuration which maximizes the ratio λ_2/λ_1 for the given volume? Is it the annular one?

An interesting and challenging problem may be (see [3, 16]):

Problem 5: Extend the composite setting to the clamped plate problem, i.e., substitute the Laplacian Δ by Δ^2 in the eigenvalue equation, and study Rayleigh's problem for it.

We end with a far reaching and highly open-ended problem:

Problem 6: To study the geometry of the free boundary for a critical (or optimal) pair.

This necessarily introduces a non-local geometric setting, since there is no “local”, or pointwise, PDE characterization of the critical (or optimal) separating hyper-surface given by the free-boundary, as is the case for many other variational problems. For example, for the minimal and constant mean curvature surfaces studied by geometers, both resulting from variational problem involving minimization of area, without or with volume constraints, respectively.

Acknowledgements. The author thanks Rob Kusner for asking him about the situation in the 1-periodic setting and Sagun Chanillo for general comments and calling the author’s attention to reference [5]. The author also thanks Assunção, Bronzi and Chumakova for the pictures in Figure 1.

References

- [1] M. S. Ashbaugh, *Open problems on eigenvalues of the Laplacian*. Analytic and geometric inequalities and applications, 13–28, Math. Appl., 478, Kluwer Acad. Publ., Dordrecht, 1999.
- [2] M. S. Ashbaugh, R. D. Benguria, *A sharp bound for the ratio of the first two eigenvalues of Dirichlet Laplacians and extensions*. Ann. of Math. (2) **135** (1992), no. 3, 601–628.
- [3] M. S. Ashbaugh, R. D. Benguria, *On Rayleigh’s conjecture for the clamped plate and its generalization to three dimensions*. Duke Math. J. **78** (1995), no. 1, 1–17.
- [4] W. Assunção, A. Bronzi, L. Chumakova, *Symmetry breaking in the minimization of the fundamental frequency of periodic composite membranes*. Final Report, NSF REU, July 2004. (Extended version in Portuguese, to appear in: Atas das Jornadas de Iniciação Científica, IMPA, Brazil, 2005.)
- [5] I. Blank, *Eliminating mixed asymptotics in obstacle type free boundary problems*. Comm. Partial Differential Equations **29** (2004), no. 7–8, 1167–1186.
- [6] J. E. Brothers and W. P. Ziemer, *Minimal rearrangements of Sobolev functions*. J. reine angew. Math. **384** (1988), 153–179.
- [7] S. Chanillo, D. Grieser, M. Imai, K. Kurata, I. Ohnishi, *Symmetry breaking and other phenomena in the optimization of eigenvalues of composite membranes*. Commun. Math. Phys. **214** (2000), 315–337.
- [8] S. Chanillo, D. Grieser, K. Kurata, *The free boundary problem in the optimization of composite membranes*. In: Proc. of the Conf. on Geometry and Control, R. Gulliver, W. Littman, R. Triggiani (eds), Contemporary Math. **268** (2000), 61–81.
- [9] S. Chanillo, C. Kenig, *Free boundaries for composites in convex domains*.
- [10] R. Courant, D. Hilbert, *Methods of Mathematical Physics, v.I*, Interscience, J. Wiley, NY, 1953
- [11] S. J. Cox, J. R. McLaughlin, *Extremal eigenvalue problems for composite membranes, I, II*. Appl. Math. Optim. **22** (1990), 153–167, 169–187.
- [12] S. J. Cox, *The two phase drum with the deepest bass note*, Japan J. Indust. Appl. Math **8** (1991), 345–355.
- [13] D. Gilbarg, N.T. Trudinger, *Elliptic Partial Differential Equations of Second Order*, Springer-Verlag, New York/Berlin, 1983.

- [14] B. Kawohl, *Rearrangements and convexity of level sets in PDE's*, LNM 1150, Springer, 1985.
- [15] M. G. Krein, *On certain problems on the maximum and minimum of characteristic values and on Lyapunov zones of stability*, AMS Translations Ser. **2** (1955), 1, 163–187.
- [16] N. Nadirashvili, *Rayleigh's conjecture on the principal frequency of the clamped plate*, Arch. Rational Mech. Anal. **129** (1995), no. 1, 1–10.
- [17] R. H. L. Pedrosa, *Minimal partial rearrangements with applications to symmetry properties of optimal composite membranes*. Preprint, 2005.
- [18] G. Pólya and G. Szegő, *Isoperimetric Inequalities in Mathematical Physics*. Ann. Math. Studies **27**, Princeton Univ. Press, Princeton, 1951.
- [19] J. W. S. Rayleigh, *The Theory of Sound*, Vols. 1, 2, Dover Publications, New York, 1945 (unabridged republication of the 2nd revised editions of 1894 (Vol. 1) and 1986 (Vol. 2), Macmillan).

Renato H.L. Pedrosa
Departamento de Matemática – IMECC
Universidade Estadual de Campinas, CP6065
13083-970 Campinas, SP
Brazil
e-mail: pedrosa@ime.unicamp.br

Generic Simplicity for the Solutions of a Nonlinear Plate Equation

A.L. Pereira and M.C. Pereira

Abstract. In this work we show that the solutions of the Dirichlet problem for a semilinear equation with the Bilaplacian as its linear part are generically simple in the set of C^4 -regular regions.

Mathematics Subject Classification (2000). 35J40, 35B30.

1. Introduction

Perturbation of the boundary for boundary value problems in PDEs have been investigated by several authors, from various points of view, since the pioneering works of Rayleigh ([11]) and Hadamard ([1]).

In particular, generic properties for solutions of boundary value problems have been considered in [4], [5], [6], [7], [8], [10], [12] and [14].

More recently several works appeared in a related topic, generally known as ‘shape analysis’ or ‘shape optimization’, on which the main issue is to determine conditions for a region to be optimal with respect to some cost functional. Among others, we mention [13] and [15].

Many problems of this kind have also been considered by D. Henry in [2] where a kind of differential calculus with the domain as the independent variable was developed. This approach allows the utilization of standard analytic tools such as Implicit Function Theorems and the Lyapunov-Schmidt method. In his work, Henry also formulated and proved a generalized form of the Transversality Theorem, which is the main tool we use in our arguments.

We consider here the semilinear equation

$$\begin{cases} \Delta^2 u(x) + f(x, u(x), \nabla u(x), \Delta u(x)) = 0 & x \in \Omega \\ u(x) = \frac{\partial u(x)}{\partial N} = 0 & x \in \partial\Omega \end{cases}$$

where $f(x, \lambda, y, \mu)$ is a C^4 real function in $\mathbb{R}^n \times \mathbb{R} \times \mathbb{R}^n \times \mathbb{R}$ with $f(x, 0, 0, 0) \equiv 0$ for all $x \in \mathbb{R}^n$.

We show that, for a residual set of regions $\Omega \subset \mathbb{R}^n$ (in a suitable topology), the solutions u of (1) are all simple, that is, the linearisation

$$L(u) : \dot{u} \rightarrow \Delta^2 \dot{u} + \frac{\partial f}{\partial \mu}(\cdot, u, \nabla u, \Delta u) \Delta \dot{u} + \frac{\partial f}{\partial y}(\cdot, u, \nabla u, \Delta u) \cdot \nabla \dot{u} + \frac{\partial f}{\partial \lambda}(\cdot, u, \nabla u, \Delta u) \dot{u}$$

is an isomorphism.

Our results can be seen as an extension of similar results for reaction-diffusion equations obtained by Saut and Teman ([12]) and Henry ([2]).

This paper is organized as follows: in section 2 we collect some results we need from [2]. In section 3 we prove that the differential operator

$$L = \Delta^2 + a(x)\Delta + b(x) \cdot \nabla + c(x) \quad x \in \mathbb{R}^n$$

is, generically, an isomorphism in the set of C^4 -regular regions $\Omega \subset \mathbb{R}^n$. This result is used in section 4 to prove our main result, the generic simplicity of solutions of (1). The most difficult point there is the proof that a certain (pseudo differential) operator is not of finite range. This was proved in a separate work ([9]).

2. Preliminaries

The results in this section were taken from the monograph of Henry [2], where full proofs can be found.

2.1. Differential Calculus of Boundary Perturbation

Given an open bounded, C^m region $\Omega_0 \subset \mathbb{R}^n$, consider the following open subset of $C^m(\Omega, \mathbb{R}^n)$

$$\text{Diff}^k(\Omega) = \{h \in C^k(\Omega, \mathbb{R}^n) \mid h \text{ is injective and } 1/|\det h'(x)| \text{ is bounded in } \Omega\}$$

We introduce a topology in the collection of all regions $\{h(\Omega) \mid h \in \text{Diff}^k(\Omega)\}$ by defining (a sub-basis of) the neighborhoods of a given Ω by

$$\{h(\Omega_0) \mid \|h - i_{\Omega_0}\|_{C^k(\Omega_0, \mathbb{R}^n)} < \epsilon, \text{ epsilon sufficiently small}\}.$$

When $\|h - i_{\Omega}\|_{C^m(\Omega, \mathbb{R}^n)}$ is small, h is a C^m imbedding of Ω in \mathbb{R}^n , a C^m diffeomorphism to its image $h(\Omega)$. Micheletti shows in [4] that this topology is metrizable, and the set of regions C^m -diffeomorphic to Ω may be considered a separable metric space which we denote by $\mathcal{M}_m(\Omega)$, or simply \mathcal{M}_m .

We say that a function F defined in the space \mathcal{M}_m with values in a Banach space is C^m or analytic if $h \mapsto F(h(\Omega))$ is C^m or analytic as a map of Banach spaces (h near i_{Ω} in $C^m(\Omega, \mathbb{R}^n)$). In this sense, we may express problems of perturbation of the boundary of a boundary value problem as problems of differential calculus in Banach spaces. More specifically, consider a formal non-linear differential operator $u \rightarrow v$

$$v(x) = f(x, u(x), Lu(x)), \quad x \in \mathbb{R}^n$$

where

$$Lu(x) = \left(u(x), \frac{\partial u}{\partial x_1}(x), \dots, \frac{\partial u}{\partial x_n}(x), \frac{\partial^2 u}{\partial x_1^2}(x), \frac{\partial^2 u}{\partial x_1 \partial x_2}(x), \dots \right), x \in \mathbb{R}^n$$

More precisely, suppose $Lu(\cdot)$ has values in \mathbb{R}^p and $f(x, \lambda)$ is defined for (x, λ) in some open set $O \subset \mathbb{R}^n \times \mathbb{R}^p$. For subsets $\Omega \subset \mathbb{R}^n$ define F_Ω by

$$F_\Omega(u)(x) = f(x, Lu(x)), x \in \Omega \tag{1}$$

for sufficiently smooth functions u in Ω such that $(x, Lu(x)) \in O$ for any $x \in \bar{\Omega}$.

Let $h : \Omega \rightarrow \mathbb{R}^n$ be C^m imbedding. We define the composition map (or *pull-back*) h^* of h by

$$h^*u(x) = (u \circ h)(x) = u(h(x)), x \in \Omega$$

where u is a function defined in $h(\Omega)$. Then h^* is an isomorphism from $C^m(h(\Omega))$ to $C^m(\Omega)$ with inverse $h^{*-1} = (h^{-1})^*$. The same is true in other function spaces.

The differential operator

$$F_{h(\Omega)} : D_{F_{h(\Omega)}} \subset C^m(h(\Omega)) \rightarrow C^0(h(\Omega))$$

given by (1) is called the *Eulerian* form of the formal operator $v \mapsto f(\cdot, Lv(\cdot))$, whereas

$$h^* F_{h(\Omega)} h^{*-1} : h^* D_{F_{h(\Omega)}} \subset C^m(\Omega) \rightarrow C^0(\Omega)$$

is called the *Lagrangian* form of the same operator.

The Eulerian form is often simpler for computations, while the Lagrangian form is usually more convenient to prove theorems, since it acts in spaces of functions that do not depend on h , facilitating the use of standard tools such as the Implicit Function or the Transversality theorem. However, a new variable, h is introduced. We then need to study the differentiability properties of the map

$$(u, h) \mapsto h^* F_{h(\Omega)} h^{*-1} u. \tag{2}$$

This has been done in [2] where it is shown that, if $(y, \lambda) \mapsto f(y, \lambda)$ is C^k or analytic then so is the map above, considered as a map from $Diff^m(\Omega) \times C^m(\Omega)$ to $C^0(\Omega)$ (other function spaces can be used instead of C^m). To compute the derivative we then need only compute the Gateaux derivative that is, the t -derivative along a smooth curve $t \mapsto (h(t, \cdot), u(t, \cdot)) \in Diff^m(\Omega) \times C^m(\Omega)$. For this purpose, it is convenient to introduce the differential operator

$$D_t = \frac{\partial}{\partial t} - U(x, t) \frac{\partial}{\partial x}, \quad U(x, t) = \left(\frac{\partial h}{\partial x} \right)^{-1} \frac{\partial h}{\partial t}$$

which is called the *anti-convective derivative*.

The results below (theorems 2.3, 2.6) are the main tools we use to compute derivatives.

Theorem 1. *Suppose $f(t, y, \lambda)$ is C^1 in an open set in $\mathbb{R} \times \mathbb{R}^n \times \mathbb{R}^p$, L is a constant-coefficient differential operator of order $\leq m$ with $Lv(y) \in \mathbb{R}^p$ (where defined). For open sets $Q \subset \mathbb{R}^n$ and C^m functions v on Q , let $F_Q(t)v$ be the function*

$$y \rightarrow f(t, y, Lv(y)), y \in Q,$$

where defined.

Suppose $t \rightarrow h(t, \cdot)$ is a curve of imbeddings of an open set $\Omega \subset \mathbb{R}^n$, $\Omega(t) = h(t, \Omega)$ and for $|j| \leq m$, $|k| \leq m + 1$ $(t, x) \rightarrow \partial_t \partial_x^j h(t, x)$, $\partial_x^k h(t, x)$, $\partial_x^k u(t, x)$ are continuous on $\mathbb{R} \times \Omega$ near $t = 0$, and $h(t, \cdot)^{*^{-1}}u(t, \cdot)$ is in the domain of $F_{\Omega(t)}$. Then, at points of Ω ,

$$D_t(h^* F_{\Omega(t)}(t)h^{*-1})(u) = (h^* \dot{F}_{\Omega(t)}(t)h^{*-1})(u) + (h^* F'_{\Omega(t)}(t)h^{*-1})(u) \cdot D_t u$$

where D_t is the anti-convective derivative defined above,

$$\dot{F}_Q(t)v(y) = \frac{\partial f}{\partial t}(t, y, Lv(y)),$$

and

$$F'_Q(t)v \cdot w(y) = \frac{\partial f}{\partial \lambda}(t, y, Lv(y)) \cdot Lw(y), \quad y \in Q$$

is the linearisation of $v \rightarrow F_Q(t)v$.

Example. Let $f(x, \lambda, y, \mu)$ be a smooth function in $\mathbb{R}^n \times \mathbb{R} \times \mathbb{R}^n \times \mathbb{R}$ and consider the nonlinear differential operator

$$F_{\Omega}(v)(x) = \Delta^2 v(x) + f(x, v(x), \nabla v(x), \Delta v(x))$$

which does not depend explicitly on t .

Suppose also that $h(t, x) = x + tV(x) + o(t)$ in a neighborhood of $t = 0$ and $x \in \Omega$. Then, since $\frac{\partial}{\partial t}(F_{\Omega}(u)) = 0$ and $F'_{\Omega}(u) \cdot w = L(u)w$, we have, by Theorem 1,

$$\begin{aligned} & \frac{\partial}{\partial t} \left(h^* F_{h(\Omega)} h^{*-1}(u) \right) \\ &= D_t \left(h^* F_{h(\Omega)} h^{*-1}(u) \right) \Big|_{t=0} - h_x^{-1} h_t \nabla \left(h^* F_{h(\Omega)} h^{*-1}(u) \right) \Big|_{t=0} \\ &= h^* F'_{h(\Omega)} h^{*-1}(u) \cdot D_t(u) \Big|_{t=0} - h_x^{-1} h_t \nabla \left(h^* F_{h(\Omega)} h^{*-1}(u) \right) \Big|_{t=0} \\ &= L(u) \left(\frac{\partial u}{\partial t} - V \cdot \nabla u \right) \\ &\quad - V \cdot \nabla \left(\Delta^2 u + f(x, u(x), \nabla u(x), \Delta u(x)) \right) \end{aligned}$$

where

$$L(u) = \Delta^2 + \frac{\partial f}{\partial \mu}(\cdot, u, \nabla u, \Delta u) \Delta + \frac{\partial f}{\partial y}(\cdot, u, \nabla u, \Delta u) \cdot \nabla + \frac{\partial f}{\partial \lambda}(\cdot, u, \nabla u, \Delta u).$$

2.2. Change of origin

We can always transfer the ‘origin’ or reference region from any $\Omega \subset \mathbb{R}^n$, to another diffeomorphic region. Indeed, if $\tilde{H} : \Omega \rightarrow \tilde{\Omega}$ is a diffeomorphism we define, for any imbedding $h : \Omega \rightarrow \mathbb{R}^n$, another imbedding $\tilde{h} = h \circ \tilde{H}^{-1} : \tilde{\Omega} \rightarrow \mathbb{R}^n$.

If $\tilde{x} = \tilde{H}(x)$, $\tilde{u} = \tilde{H}^{-1} * u N_{\tilde{\Omega}}(\tilde{x}) = N_{\tilde{H}(\Omega)}(\tilde{H}(x)) = \frac{\tilde{H}_x^t N_{\Omega}(x)}{\|\tilde{H}_x^t N_{\Omega}(x)\|}$ then $h(\Omega) = \tilde{h}(\tilde{\Omega})$,

$$h^* F_{h(\Omega)} h^{*-1} u(x) = \tilde{h}^* F_{\tilde{h}(\tilde{\Omega})} (\tilde{h}^*)^{-1} \tilde{u}(\tilde{x}),$$

$$h^* \mathcal{B}_h(\Omega) h^{*-1} u(x) = \tilde{h}^* \mathcal{B}_{\tilde{h}(\tilde{\Omega})}(\tilde{h}^*)^{-1} \tilde{u}(\tilde{x}),$$

using the normal

$$\begin{aligned} N_{\tilde{h}(\tilde{\Omega})}(\tilde{h}(\tilde{x})) &= \frac{(\tilde{h}^{-1})_{\tilde{x}}^t N_{\tilde{\Omega}}(\tilde{x})}{\|(\tilde{h}^{-1})_{\tilde{x}}^t N_{\tilde{\Omega}}(\tilde{x})\|} \\ &= \frac{(h^{-1})_x^t N_{\Omega}(x)}{\|(h^{-1})_x^t N_{\Omega}(x)\|} \\ &= N_{h(\Omega)}(h(x)). \end{aligned}$$

This ‘change of origin’ will be frequently used in the sequel, as it allow us to compute derivatives with respect to h at $h = i_{\Omega}$, where the formulas are simpler.

2.3. The Transversality Theorem

A basic tool for our results will be the Transversality Theorem in the form below, due to D. Henry [2]. We first recall some definitions.

A map $T \in \mathcal{L}(X, Y)$ where X and Y are Banach spaces is a *semi-Fredholm* map if the range of T is closed and at least one (or both, for Fredholm) of $\dim \mathcal{N}(T)$, $\text{codim } \mathcal{R}(T)$ is finite; the *index* of T is then

$$\text{index}(T) = \text{ind}(T) = \dim \mathcal{N}(T) - \text{codim} \mathcal{R}(T).$$

We say that a subset F of a topological space X is *rare* if its closure has empty interior and *meager* if it is contained in a countable union of rare subsets of X .

We say that F is *residual* if its complement in X is meager. We also say that X is a *Baire space* if any residual subset of X is dense.

Let f be a C^k map between Banach spaces. We say that x is a *regular point* of f if the derivative $f'(x)$ is surjective and its kernel is finite-dimensional. Otherwise, x is called a *critical point* of f . A point is a *critical value* if it is the image of some critical point of f .

Let now X be a Baire space and $I = [0, 1]$. For any closed or σ -closed $F \subset X$ and any nonnegative integer m we say that the codimension of F is greater or equal to m ($\text{codim } F \geq m$) if the subset $\{\phi \in \mathcal{C}(I^m, X) \mid \phi(I^m) \cap F \text{ is non-empty}\}$ is meager in $\mathcal{C}(I^m, X)$. We say $\text{codim } F = k$ if k is the largest integer satisfying $\text{codim } F \geq m$. $\text{codim } F \geq m$.

Theorem 2. *Suppose given positive numbers k and m ; Banach manifolds X, Y, Z of class C^k ; an open set $A \subset X \times Y$; a C^k map $f : A \rightarrow Z$ and a point $\xi \in Z$. Assume for each $(x, y) \in f^{-1}(\xi)$ that:*

1. $\frac{\partial f}{\partial x}(x, y) : T_x X \rightarrow T_{\xi} Z$ is semi-Fredholm with index $< k$.
2. (α) $Df(x, y) : T_x X \times T_y Y \rightarrow T_{\xi} Z$ is surjective

or

$$(\beta) \dim \left\{ \frac{\mathcal{R}(Df(x, y))}{\mathcal{R}(\frac{\partial f}{\partial x}(x, y))} \right\} \geq m + \dim \mathcal{N}(\frac{\partial f}{\partial x}(x, y)).$$

3. $(x, y) \mapsto y : f^{-1}(\xi) \longrightarrow Y$ is σ -proper, that is $f^{-1}(\xi)$ is a countable union of sets M_j such that $(x, y) \mapsto y : M_j \longrightarrow Y$ is a proper map for each j . [Given $(x_n, y_n) \in M_j$ such that $\{y_n\}$ converges in Y , there exists a subsequence (or subnet) with limit in M_j .]

We note that 3 holds if $f^{-1}(\xi)$ is Lindelöf (every open cover has a countable subcover) or, more specifically, if $f^{-1}(\xi)$ is a separable metric space, or if X, Y are separable metric spaces.

Let $A_y = \{x | (x, y) \in A\}$ and

$$Y_{crit} = \{y \mid \xi \text{ is a critical value of } f(\cdot, y) : A_y \mapsto Z\}.$$

Then Y_{crit} is a meager set in Y and, if $(x, y) \mapsto y : f^{-1}(\xi) \mapsto Y$ is proper, Y_{crit} is also closed. If $\text{ind } \frac{\partial f}{\partial x} \leq -m < 0$ on $f^{-1}(\xi)$, then $(2(\alpha))$ implies $(2(\beta))$ and

$$Y_{crit} = \{y \mid \xi \in f(A_y, y)\}$$

has codimension $\geq m$ in Y . (Note Y_{crit} is meager iff $\text{codim } Y_{crit} \geq 1$.)

3. Genericity of the isomorphism property for a class of linear differential operators

Let $a : \mathbb{R}^n \rightarrow \mathbb{R}, b : \mathbb{R}^n \rightarrow \mathbb{R}^n$ and $c : \mathbb{R}^n \rightarrow \mathbb{R}$ be functions of class \mathcal{C}^3 and consider the (formal) differential operator

$$L = \Delta^2 + a(x)\Delta + b(x) \cdot \nabla + c(x) \quad x \in \mathbb{R}^n.$$

We show in this section that the operator

$$\begin{aligned} L_\Omega : H^4 \cap H_0^2(\Omega) &\rightarrow L^2(\Omega) \\ u &\rightarrow Lu \end{aligned} \tag{3}$$

is, generically, an isomorphism in the set of open, connected, bounded \mathcal{C}^3 -regular regions of \mathbb{R}^n . More precisely, we show that the set

$$\mathcal{I} = \{h \in \text{Diff}^4(\Omega) \mid \text{the operator } h^*L_{h(\Omega)}h^{*-1} \text{ from } H^4 \cap H_0^2(\Omega) \text{ into } L^2(\Omega) \text{ is an isomorphism} \} \tag{4}$$

is an open dense set in $\text{Diff}^4(\Omega)$. Observe that the operator $h^*L_{h(\Omega)}h^{*-1}$ is an isomorphism if, and only if the operator $L_{h(\Omega)}$ from $H^4 \cap H_0^2(h(\Omega))$ to $L^2(h(\Omega))$ is an isomorphism, since h^* and h^{*-1} are isomorphisms from $L^2(h(\Omega))$ to $L^2(\Omega)$ and $H^4 \cap H_0^2(\Omega)$ to $H^4 \cap H_0^2(h(\Omega))$ respectively. Consider the differentiable map

$$\begin{aligned} K : H^4 \cap H_0^2(\Omega) \times \text{Diff}^4(\Omega) &\rightarrow L^2(\Omega) \\ (u, h) &\rightarrow h^*L_{h(\Omega)}h^{*-1}u. \end{aligned} \tag{5}$$

Proposition 3. *Let $a : \mathbb{R}^n \rightarrow \mathbb{R}, b : \mathbb{R}^n \rightarrow \mathbb{R}^n, c : \mathbb{R}^n \rightarrow \mathbb{R}$ be C^2 functions, $\Omega \subset \mathbb{R}^n$ an open, connected bounded C^4 -regular region, and $h \in \text{Diff}^4(\Omega)$. Then zero is a regular value of the map (application)*

$$\begin{aligned} K_h : H^4 \cap H_0^2(\Omega) &\longrightarrow L^2(\Omega) \\ u &\longrightarrow h^* L_{h(\Omega)} h^{*-1} u, \end{aligned}$$

if and only if $h^ L_{h(\Omega)} h^{*-1}$ is an isomorphism.*

Proof. First observe that K_h is a Fredholm operator of index 0 since $L_{h(\Omega)}$ is Fredholm of index 0 and h^*, h^{*-1} are isomorphisms. If 0 is a regular value then the linearisation of K_h at 0, which is again K_h , must be surjective. Being of index 0 it is also injective and therefore an isomorphism by the Open Mapping Theorem. Reciprocally, if K_h is an isomorphism, it is surjective at any point. \square

From 3 and the Implicit Function Theorem it follows that \mathcal{I} is open. We thus only need to show density. For that we may work with more regular regions.

It would be very convenient for our purposes to have the following ‘unique continuation’ result.

If u is a solution of $L_\Omega u = 0$ with $\frac{\partial^2 u}{\partial N^2} = 0$ in a open set of $\partial\Omega$, then $u \equiv 0$.

Such a result is not available, to the best of our knowledge, but the following ‘generic unique continuation result’ will be sufficient for our needs. We will not prove it here since the argument is very similar to the one of 11 below.

Lemma 4. *Let $\Omega \subset \mathbb{R}^n$ be an open, connected, bounded C^5 -regular region with $n \geq 2$ and J an open nonempty subset of $\partial\Omega$. Consider the differentiable map*

$$G : B_M \times \text{Diff}^5(\Omega) \rightarrow L^2(\Omega) \times H^{\frac{3}{2}}(J)$$

defined by

$$G(u, h) = \left(h^* L_{h(\Omega)} h^{*-1} u, h^* \Delta h^{*-1} u \Big|_J \right)$$

where $B_M = \{u \in H^4 \cap H_0^2(\Omega) - \{0\} \mid \|u\| \leq M\}$. Then, the set

$$C_M^J = \{h \in \text{Diff}^5(\Omega) \mid (0, 0) \in G(B_M, h)\}$$

is meager and closed in $\text{Diff}^5(\Omega)$.

Theorem 5. *Let $a : \mathbb{R}^n \rightarrow \mathbb{R}, b : \mathbb{R}^n \rightarrow \mathbb{R}^n$ and $c : \mathbb{R}^n \rightarrow \mathbb{R}$ be functions of class C^3 . Then the operator L_Ω defined in (3) is generically an isomorphism in the set of open, connected C^4 -regular regions $\Omega \subset \mathbb{R}^n, n \geq 2$. More precisely, if $\Omega \subset \mathbb{R}^n (n \geq 2)$ is an open, connected C^4 -regular region, than the set \mathcal{I} defined in (4) is an open dense set in $\text{Diff}^4(\Omega)$.*

Proof. By proposition 3, all we need to show is that 0 is a regular value of K_h in a residual subset of $\text{Diff}^4(\Omega)$. Since our spaces are separable and K_h is Fredholm of index 0, this would follow from the Transversality Theorem if we could prove that 0 is a regular value of K . Let us suppose that this is not true, that is, there exists a critical point $(u, h) \in K^{-1}(0)$. As explained in (2.2), we may suppose that $h = i_\Omega$.

Since we only need to prove density, we may also suppose that Ω is \mathcal{C}^5 -regular. Then, there exists $v \in L^2(\Omega)$ such that

$$\int_{\Omega} vDK(u, i_{\Omega})(\dot{u}, \dot{h}) = 0 \text{ for all } (\dot{u}, \dot{h}) \in H^4 \cap H_0^2(\Omega) \times \mathcal{C}^5(\Omega, \mathbb{R}^n) \tag{6}$$

where $DK(u, i_{\Omega})$ from $H^4 \cap H_0^2(\Omega) \times \mathcal{C}^5(\Omega, \mathbb{R}^n)$ to $L^2(\Omega)$ is given by

$$DK(u, i_{\Omega})(\dot{u}, \dot{h}) = L_{\Omega}(\dot{u} - \dot{h} \cdot \nabla u).$$

Choosing $\dot{h} = 0$ and varying \dot{u} in $H^4 \cap H_0^2(\Omega)$, we obtain

$$\int_{\Omega} vL_{\Omega}\dot{u} = 0 \text{ for all } \dot{u} \in H^4 \cap H_0^2(\Omega)$$

and v is therefore a weak, hence strong, solution of

$$L_{\Omega}^*v = 0 \text{ in } \Omega \tag{7}$$

where L_{Ω}^* from $H^4 \cap H_0^2(\Omega)$ to $L^2(\Omega)$ is given by

$$L_{\Omega}^*v = \Delta^2v + a\Delta v + (2\nabla a - b) \cdot \nabla v + (c + \Delta a - \operatorname{div} b)v.$$

By regularity of solutions of strongly elliptic equations, v is also a strong solution, that is, $v \in H^4 \cap H_0^2(\Omega) \cap \mathcal{C}^{4,\alpha}(\Omega)$ for some $\alpha > 0$ and satisfies (7) (Note that $u \in H^5(\Omega)$, since Ω is \mathcal{C}^5 -regular.)

Choosing $\dot{u} = 0$ and varying \dot{h} in $\mathcal{C}^5(\Omega, \mathbb{R}^n)$, we obtain

$$0 = - \int_{\Omega} vL_{\Omega}(\dot{h} \cdot \nabla u) = \int_{\Omega} \{(\dot{h} \cdot \nabla u)L_{\Omega}^*v - vL_{\Omega}(\dot{h} \cdot \nabla u)\} = \int_{\partial\Omega} \dot{h} \cdot N\Delta v\Delta u,$$

for all $\dot{h} \in \mathcal{C}^5(\Omega, \mathbb{R}^n)$ since $\Delta u|_{\partial\Omega} = \frac{\partial^2 u}{\partial N^2}|_{\partial\Omega}$. Thus $\Delta v\Delta u \equiv 0$ in $\partial\Omega$. This is not a contradiction (or at least it is not clear that it is). We show now, however, that it is a contradiction generically; it can only happen in an ‘exceptional’ set of $\operatorname{Diff}^4(\Omega)$. The result then follows by reapplying the argument above outside this exceptional set. To be more precise, consider the map

$$H : B_M^2 \times \operatorname{Diff}^5(\Omega) \rightarrow L^2(\Omega)^2 \times L^1(\partial\Omega)$$

defined by

$$H(u, v, h) = (K(u, h), h^*L_{h(\Omega)}^*h^{*-1}v, h^*\Delta h^{*-1}uh^*\Delta h^{*-1}v|_{\partial\Omega})$$

where $B_M^2 = \{(u, v) \in H^4 \cap H_0^2(\Omega)^2 \mid \|u\|, \|v\| \leq M\}$. We show, using the Transversality Theorem that the set

$$\mathcal{H}_M = \{h \in \operatorname{Diff}^5(\Omega) \mid (0, 0, 0) \in H(B_M^2, h)\}$$

is meager and closed in $\operatorname{Diff}^5(\Omega)$ for all $M \in \mathbb{N}$. We may, by ‘changing the origin’ if necessary assume that the ‘generic uniqueness property’ stated in Lemma 4 holds in Ω . We then apply the Transversality Theorem again for the map K , with h restricted to the complement of \mathcal{H}_M , obtaining another subset $\tilde{\mathcal{H}}_M$ of $\operatorname{Diff}^5(\Omega)$. such that 0 is a regular value of K_h for any $h \in \tilde{\mathcal{H}}_M$. Taking intersection for $M \in \mathbb{N}$, the desired result follows.

To show that \mathcal{H}_M is a meager closed set we apply Henry’s version of the Transversality Theorem for the map H . Since our spaces are separable and $\frac{\partial K}{\partial u}(u, i_{\partial\Omega})$ is Fredholm it remains only to prove that the map $(u, v, h) \mapsto h : H^{-1}(0, 0, 0) \rightarrow \text{Diff}^5(\Omega)$ is proper and the hypothesis (2 β). We first show that $(u, v, h) \rightarrow h : H^{-1}(0, 0, 0) \rightarrow \text{Diff}^5(\Omega)$ is proper. Let $\{(u_n, v_n, h_n)\}_{n \in \mathbb{N}} \subset H^{-1}(0, 0, 0)$ be a sequence with $h_n \rightarrow i_{\Omega}$ in $\text{Diff}^5(\Omega)$ (the general case is similar). Since $\{(u_n, v_n)\}_{n \in \mathbb{N}} \subset B_M^2$, we may assume, taking a subsequence that there exists $(u, v) \in H_0^2(\Omega)^2$ such that $u_n \rightarrow u$ and $v_n \rightarrow v$ in $H_0^2(\Omega)$. We have, for all $n \in \mathbb{N}$,

$$h_n^* (\Delta^2 + a\Delta + b \cdot \nabla + c) h_n^{*-1} u_n = 0 \iff h_n^* \Delta^2 h_n^{*-1} u_n = -h_n^* (a\Delta + b \cdot \nabla + c) h_n^{*-1} u_n.$$

Since Δ^2 is an isomorphism, it follows that

$$u_n = -h_n^* (\Delta^2)^{-1} (a\Delta + b \cdot \nabla + c) h_n^{*-1} u_n \tag{8}$$

By the results in section 2.1, the right-hand side of (8) is analytic as an application from $H_0^2(\Omega) \times \text{Diff}^5(\Omega)$ to $H^4 \cap H_0^2(\Omega)$. Taking the limit as $n \rightarrow +\infty$, we obtain that $u \in H^4 \cap H_0^2(\Omega)$ and satisfies $\Delta^2 u + a\Delta u + b \cdot \nabla u + cu = 0$. By Lemma 10 of [10] we have, for $h \in \text{Diff}^5(\Omega)$ and $v \in H^4 \cap H_0^2(\Omega)$

$$h^* \Delta^2 h^{*-1}(v) = \Delta^2(v) + L^h(v) \text{ with } \|L^h u\|_{L^2(\Omega)} \leq \epsilon(h) \|u\|_{H^4(\Omega)}$$

and $\epsilon(h) \rightarrow 0$ as $h \rightarrow i_{\Omega}$ in $\mathcal{C}^4(\Omega, \mathbb{R}^n)$.

Since $u_n \rightarrow u$ in $H_0^2(\Omega)$ and $h_n \rightarrow i_{\Omega}$ in $\text{Diff}^5(\Omega)$ as $n \rightarrow +\infty$, we obtain

$$\begin{aligned} \|\Delta^2(u_n - u) + L^{h_n}(u_n - u)\|_{L^2(\Omega)} &= \|h_n^* \Delta^2 h_n^{*-1}(u_n - u)\|_{L^2(\Omega)} \\ &= \|h_n^* \Delta^2 h_n^{*-1} u + h_n^* (a\Delta + b \cdot \nabla + c) h_n^{*-1} u_n\|_{L^2(\Omega)} \\ &\rightarrow \|\Delta^2 u + a\Delta u + b \cdot \nabla u + cu\|_{L^2(\Omega)} = 0 \end{aligned} \tag{9}$$

as $n \rightarrow +\infty$.

Since $\{(u_n, v_n)\} \subset B_M^2$ and $h_n \rightarrow i_{\Omega}$ in $\text{Diff}^5(\Omega)$, we have

$$\|L^{h_n}(u_n - u)\|_{L^2(\Omega)} \leq 2M\epsilon(h_n). \tag{10}$$

It follows from (9) and (10) that $\|\Delta^2(u_n - u)\|_{L^2(\Omega)} \rightarrow 0$ as $n \rightarrow +\infty$. Since Δ^2 is an isomorphism from $H^4 \cap H_0^2(\Omega)$ to $L^2(\Omega)$, we obtain $u_n \rightarrow u$ in $H^4 \cap H_0^2(\Omega)$ and, therefore $\|u\|_{H^4 \cap H_0^2(\Omega)} \leq M$, for all $n \in \mathbb{N}$. Similarly, we prove that $v_n \rightarrow v$ in $H^4 \cap H_0^2(\Omega)$ and $\|v\|_{H^4 \cap H_0^2(\Omega)} \leq M$ from which we conclude that the map $(u, v, h) \rightarrow h : H^{-1}(0, 0, 0) \rightarrow \text{Diff}^5(\Omega)$ is proper.

It remains only to prove (2 β), which we do by showing that

$$\dim \left\{ \frac{\mathcal{R}(DH(u, v, h))}{\mathcal{R}\left(\frac{\partial H}{\partial u}(u, v, h)\right)} \right\} = \infty \text{ for all } (u, v, h) \in H^{-1}(0, 0, 0).$$

Suppose this is not true for some $(u, v, h) \in H^{-1}(0, 0, 0)$. Assuming, as we may, that $h = i_{\Omega}$ it follows that there exist $\theta_1, \dots, \theta_m \in L^2(\Omega)^2 \times L^1(\partial\Omega)$ such that, for

all $\dot{h} \in C^5(\Omega, \mathbb{R}^n)$ there exist $\dot{u}, \dot{v} \in H^4 \cap H_0^2(\Omega)$ and scalars $c_1, \dots, c_m \in \mathbb{R}$ such that

$$DH(u, v, i_\Omega)(\dot{u}, \dot{v}, \dot{h}) = \sum_{i=1}^m c_i \theta_i, \quad \theta_i = (\theta_i^1, \theta_i^2, \theta_i^3). \tag{11}$$

Using theorem 1, we obtain

$$DH(u, v, i_\Omega)(\cdot) = \left(DH_1(u, v, i_\Omega)(\cdot), DH_2(u, v, i_\Omega)(\cdot), DH_3(u, v, i_\Omega)(\cdot) \right)$$

where

$$\begin{aligned} DH_1(u, v, i_\Omega)(\dot{u}, \dot{v}, \dot{h}) &= L_\Omega(\dot{u} - \dot{h} \cdot \nabla u) \\ DH_2(u, v, i_\Omega)(\dot{u}, \dot{v}, \dot{h}) &= L_\Omega^*(\dot{v} - \dot{h} \cdot \nabla v) \\ DH_3(u, v, i_\Omega)(\dot{u}, \dot{v}, \dot{h}) &= \left\{ \Delta v \Delta(\dot{u} - \dot{h} \cdot \nabla u) + \Delta u \Delta(\dot{v} - \dot{h} \cdot \nabla v) \right. \\ &\quad \left. + \dot{h} \cdot N \frac{\partial}{\partial N}(\Delta u \Delta v) \right\} \Big|_{\partial\Omega}. \end{aligned}$$

It follows from (11) that

$$L_\Omega(\dot{u} - \dot{h} \cdot \nabla u) = \sum_{i=1}^m c_i \theta_i^1 \tag{12}$$

$$L_\Omega^*(\dot{v} - \dot{h} \cdot \nabla v) = \sum_{i=1}^m c_i \theta_i^2 \tag{13}$$

$$\begin{aligned} \sum_{i=1}^m c_i \theta_i^3 &= \left\{ \Delta v \Delta(\dot{u} - \dot{h} \cdot \nabla u) + \Delta u \Delta(\dot{v} - \dot{h} \cdot \nabla v) \right. \\ &\quad \left. + \dot{h} \cdot N \frac{\partial}{\partial N}(\Delta u \Delta v) \right\} \Big|_{\partial\Omega}. \end{aligned} \tag{14}$$

Let $\{u_1, \dots, u_l\}$ be a basis for the kernel of L_Ω and consider the operators

$$\mathcal{A}_L : L^2(\Omega) \rightarrow H^4 \cap H_0^1(\Omega)$$

$$\mathcal{C}_L : H^{\frac{5}{2}}(\partial\Omega) \rightarrow H^4 \cap H_0^1(\Omega)$$

defined by

$$w = \mathcal{A}_L(z) + \mathcal{C}_L(g)$$

where $Lw - z$ belongs to a (fixed) complement of $\mathcal{R}(L_\Omega)$ in $L^2(\Omega)$, $\frac{\partial w}{\partial N} = g$ on $\partial\Omega$ and $\int_\Omega w \phi = 0$ for all $\phi \in \mathcal{N}(L_\Omega^*)$. Let also $\{v_1, \dots, v_l\}$ be a basis for the kernel of L_Ω^* and consider the operators

$$\mathcal{A}_{L^*} : L^2(\Omega) \rightarrow H^4 \cap H_0^1(\Omega) \text{ and}$$

$$\mathcal{C}_{L^*} : H^{\frac{5}{2}}(\partial\Omega) \rightarrow H^4 \cap H_0^1(\Omega)$$

similarly defined. We have shown in [9] that these operators are well defined.

From equations (12) and (13), we obtain

$$\dot{u} - \dot{h} \cdot \nabla u = \sum_{i=1}^l \xi_i u_i + \sum_{i=1}^m c_i \mathcal{A}_L \theta_i^1 - \mathcal{C}_L(\dot{h} \cdot N \Delta u) \tag{15}$$

since $\frac{\partial}{\partial N}(\dot{u} - \dot{h} \cdot \nabla u)|_{\partial\Omega} = -\dot{h} \cdot N \frac{\partial^2 u}{\partial N^2}|_{\partial\Omega} = -\dot{h} \cdot N \Delta u|_{\partial\Omega}$ and

$$\dot{v} - \dot{h} \cdot \nabla v = \sum_{i=1}^l \eta_i v_i + \sum_{i=1}^m c_i \mathcal{A}_{L^*} \theta_i^1 - \mathcal{C}_{L^*}(\dot{h} \cdot N \Delta v) \tag{16}$$

since $\frac{\partial}{\partial N}(\dot{v} - \dot{h} \cdot \nabla v)|_{\partial\Omega} = -\dot{h} \cdot N \frac{\partial^2 v}{\partial N^2}|_{\partial\Omega} = -\dot{h} \cdot N \Delta v|_{\partial\Omega}$.

Substituting (15) and (16) in (14), we obtain that

$$\left\{ \dot{h} \cdot N \frac{\partial}{\partial N}(\Delta u \Delta v) - \left[\Delta u \Delta \mathcal{C}_{L^*}(\dot{h} \cdot N \Delta v) + \Delta v \Delta \mathcal{C}_L(\dot{h} \cdot N \Delta u) \right] \right\} \Big|_{\partial\Omega} \tag{17}$$

remains in a finite dimensional space when \dot{h} varies in $\mathcal{C}^5(\Omega, \mathbb{R}^n)$.

The set $U = \{x \in \partial\Omega \mid \Delta u(x) \neq 0\}$ is nonempty since we have assumed that ‘generic unique continuation’ holds in Ω . Therefore, we must have $\Delta v|_U \equiv 0$. If $\dot{h} \equiv 0$ in $\partial\Omega - U$, then $\dot{h} \cdot N \Delta v \equiv 0$ in $\partial\Omega$ and, therefore

$$\Delta u \Delta \mathcal{C}_{L^*}(\dot{h} \cdot N \Delta v) = \Delta u \Delta \mathcal{C}_{L^*}(0)$$

belongs to the finite dimensional space $[\Delta u \Delta v_1, \dots, \Delta u \Delta v_l]$ where $\{v_1, \dots, v_l\}$ is a basis for the kernel of $\mathcal{N}(L^*)$. It follows that

$$\begin{aligned} \left\{ \dot{h} \cdot N \frac{\partial}{\partial N}(\Delta u \Delta v) - \Delta v \Delta \mathcal{C}_L(\dot{h} \cdot N \Delta u) \right\} \Big|_U &= \dot{h} \cdot N \frac{\partial}{\partial N}(\Delta u \Delta v) \Big|_U \\ &= \dot{h} \cdot N \Delta u \frac{\partial}{\partial N}(\Delta v) \Big|_U \end{aligned} \tag{18}$$

remains in a finite dimensional space, when \dot{h} varies in $\mathcal{C}^5(\Omega, \mathbb{R}^n)$ with $\dot{h} \equiv 0$ in $\partial\Omega - U$. Since $\Delta u(x) \neq 0$ for any $x \in U$, this is only possible ($\dim \Omega \geq 2$) if $\frac{\partial \Delta v}{\partial N} \Big|_U \equiv 0$. But then $v \equiv 0$ in Ω by Theorem 6 below, and we reach a contradiction proving the result. \square

During the proof of theorem 5 we have used the following uniqueness theorem, which is a direct consequence of Theorem 8.9.1 of [3].

Theorem 6. *Suppose $\Omega \subset \mathbb{R}^n$ is an open connected, bounded, C^4 -regular domain and B is an open ball in \mathbb{R}^n such that $B \cap \partial\Omega$ is a (nontrivial) C^4 hypersurface. Suppose also that $u \in H^4(\Omega)$ satisfies*

$$|\Delta^2 u| \leq C \left(|\Delta u| + |\nabla u| + |u| \right) \text{ a.e. in } \Omega$$

for some positive constant C and $u = \frac{\partial u}{\partial N} = \Delta u = \frac{\partial \Delta u}{\partial N} = 0$ in $B \cap \partial\Omega$. Then u is identically null.

4. Generic simplicity of solutions

Let $f(x, \lambda, y, \mu)$ be a real function of class C^4 defined in $\mathbb{R}^n \times \mathbb{R} \times \mathbb{R}^n \times \mathbb{R}$ satisfying $f(x, 0, 0, 0) \equiv 0$ for all $x \in \mathbb{R}^n$. We prove in this section our main result: generically in the set of connected, bounded C^4 -regular regions $\Omega \subset \mathbb{R}^n$, $n \geq 2$, the solutions u of

$$\begin{cases} \Delta^2 u + f(\cdot, u, \nabla u, \Delta u) = 0 & \text{in } \Omega \\ u = \frac{\partial u}{\partial N} = 0 & \text{on } \partial\Omega \end{cases} \tag{19}$$

are all simple. We choose $p > \frac{n}{2}$, so that the continuous imbedding $p, W^{4,p} \cap W_0^{2,p}(\Omega) \hookrightarrow C^{2,\alpha}(\Omega)$ holds for some $\alpha > 0$.

It follows then, from the Implicit Function Theorem, that the set of solutions is discrete in $W^{4,p} \cap W_0^{2,p}(\Omega)$ and, in particular finite if f is bounded.

Remark 7. Since we have assumed $f(x, 0, 0, 0) \equiv 0$ in \mathbb{R}^n , the null function $u \equiv 0$ is a solution of (19) for any $\Omega \subset \mathbb{R}^n$. It follows from theorem 5 that $u \equiv 0$ is simple for Ω in an open dense set of $\text{Diff}^4(\Omega)$. We therefore concentrate in the proof of generic simplicity for the nontrivial solutions.

Proposition 8. *Let $\Omega \subset \mathbb{R}^n$ be an open, connected bounded C^4 -regular region and $f(x, \lambda, y, \mu)$ a C^2 real function defined in $\mathbb{R}^n \times \mathbb{R} \times \mathbb{R}^n \times \mathbb{R}$. Then, zero is a regular value of the map*

$$\begin{aligned} F_h : W^{2,p} \cap W_0^{1,p}(\Omega) &\longrightarrow L^p(\Omega) \\ u &\longrightarrow h^* \Delta^2 h^{*-1} u + h^* f(\cdot, h^{*-1} u, \nabla h^{*-1} u, \Delta h^{*-1} u), \end{aligned}$$

if and only if all solutions of (19) in $h(\Omega)$ are simple.

Proof. The proof is very similar to the one of proposition 3 and will be left to the reader. □

Proposition 9. *A function $u \in W^{4,p} \cap W_0^{2,p}(\Omega)$ is a solution (resp. a simple solution) of*

$$\begin{cases} h^* \Delta^2 h^{*-1} u + h^* f(\cdot, h^{*-1} u, \nabla h^{*-1} u, \Delta h^{*-1} u) = 0 & \text{in } \Omega, \\ u = \frac{\partial u}{\partial N} = 0 & \text{on } \partial\Omega \end{cases} \tag{20}$$

if and only if $v = h^{*-1} u$ is a solution (resp. simple solution) of (19) in $h(\Omega)$.

Proof. Let $u \in W^{4,p} \cap W_0^{2,p}(\Omega)$. Since h^* and h^{*-1} are isomorphisms, we have

$$\begin{aligned} h^* \Delta^2 h^{*-1} u + h^* f(\cdot, h^{*-1} u, \nabla h^{*-1} u, \Delta h^{*-1} u) &= 0 \\ \iff \Delta^2 h^{*-1} u + f(\cdot, h^{*-1} u, \nabla h^{*-1} u, \Delta h^{*-1} u) &= 0, \end{aligned}$$

It is clear that $u = 0$ in $\partial\Omega$ if and only if $v = 0$ in $\partial h(\Omega)$. Writing $y = h(x)$, we obtain

$$\begin{aligned} \frac{\partial v}{\partial N_{h(\Omega)}}(y) &= N_{h(\Omega)}(y) \cdot \nabla_y(u \circ h^{-1})(y) \\ &= N_{h(\Omega)}(y) \cdot (h^{-1})_y^t(y) \nabla_x u(x) \\ &= N_{h(\Omega)}(y) \cdot (h_x^{-1})^t(x) \nabla_x u(x) \\ &= N_{h(\Omega)}(y) \cdot ((h_x)^{-1})^t(x) \frac{\partial u}{\partial N}(x) N_\Omega(x) \\ &= \frac{\partial u}{\partial N}(x) \frac{1}{\|(h_x^{-1})^t N_\Omega(x)\|} ((h_x^{-1})^t(x) N_\Omega(x) \cdot (h_x^{-1})^t(x) N_\Omega(x)) \end{aligned}$$

where we have used that $u = 0$ in $\partial\Omega$. Since $h_x^{-1}(x)$ is non-singular it follows that $\frac{\partial v}{\partial N_{h(\Omega)}}(y) = 0$ if and only if $\frac{\partial u}{\partial N}(x) = 0$. Thus u is a solution of (20) if and only if $h^{*-1}u$ is a solution of (19) in $h(\Omega)$. Finally, since $h^*L(u)h^{*-1}$ is an isomorphism in $W^{4,p} \cap W_0^{2,p}(\Omega)$ if and only if $L(v)$ is an isomorphism in $W^{4,p} \cap W_0^{2,p}(h(\Omega))$ so the result follows. □

It follows from (9) and (8) that, in order to show generic simplicity of the solutions of (19) is enough to show that 0 is a regular value of F_h , generically in $h \in \text{Diff}^4(\Omega)$. We show, using the Transversality Theorem, that 0 is a regular value of

$$\begin{aligned} F_M : B_M \times V_M &\rightarrow L^p(\Omega) \\ (u, h) &\rightarrow h^* \Delta^2 h^{*-1} u + h^* f(\cdot, h^{*-1} u, \nabla h^{*-1} u, \Delta h^{*-1} u) \end{aligned} \tag{21}$$

where $B_M = \{u \in W^{4,p} \cap W_0^{2,p}(\Omega) - \{0\} \mid \|u\| \leq M\}$ and V_M is an open dense set in $\text{Diff}^4(\Omega)$, for all $M \in \mathbb{N}$. Taking the intersection of V_M for $M \in \mathbb{N}$ we obtain the desired residual set.

Remark 10. Applying the Implicit Function Theorem to the map F_M defined in (21) we obtain that the set

$$\mathcal{F}_M = \{h \in \text{Diff}^4(\Omega) \mid \text{all solutions } u \text{ of (20) with } \|u\|_{W^{4,p} \cap W_0^{2,p}(\Omega)} < M \text{ are simple} \}$$

is open in $\text{Diff}^4(\Omega)$ for all $M \in \mathbb{N}$. To prove density, we may work with more regular (for example C^∞) regions.

If we try to apply the Transversality Theorem directly to the function F defined in $W^{4,p} \cap W_0^{2,p}(\Omega) \times \text{Diff}^4(\Omega)$ by (21) we do not obtain a contradiction. What we do obtain is that the possible critical points must satisfy very special properties. The idea is then to show that these properties can only occur in a small (meager and closed) set and then restrict the problem to its complement. In our case the ‘exceptional situation’ is characterized by the existence of a solution u of

(19) and a solution v of the problem

$$\begin{cases} L^*(u)v = 0 & \text{in } \Omega \\ v = \frac{\partial v}{\partial N} = 0 & \text{on } \partial\Omega \end{cases}$$

satisfying the additional property $\Delta u \Delta v \equiv 0$ on $\partial\Omega$. We show in Lemma 12 that this situation is really ‘exceptional’, that is, it can only happen if h is outside an open dense subset of $\text{Diff}^4(\Omega)$ (for u and v restricted to a bounded set).

We will need the following ‘generic unique continuation result’.

Lemma 11. *Let $\Omega \subset \mathbb{R}^n$ $n \geq 2$ be an open, connected, bounded, \mathcal{C}^5 -regular domain, J a nonempty open subset of Ω and $f(x, \lambda, y, \mu)$ a \mathcal{C}^2 real function defined in $\mathbb{R}^n \times \mathbb{R} \times \mathbb{R}^n \times \mathbb{R}$ with $f(\cdot, 0, 0, 0) \equiv 0$. Consider the map*

$$G : A_M \times \text{Diff}^5(\Omega) \rightarrow L^p(\Omega) \times W^{2-\frac{1}{p}, p}(J)$$

defined by

$$G(u, h) = \left(h^* \Delta^2 h^{*-1} u + h^* f(\cdot, h^{*-1} u, \nabla h^{*-1} u, \Delta h^{*-1} u), h^* \Delta h^{*-1} u \Big|_J \right)$$

where $A_M = \{u \in W^{4,p} \cap W_0^{2,p}(\Omega) - \{0\} \mid \|u\| \leq M\}$, and $p > \frac{n}{2}$. Then

$$\mathcal{C}_M^J = \{h \in \text{Diff}^5(\Omega) \mid (0, 0) \in G(A_M, h)\}$$

is a closed meager subset of $\text{Diff}^5(\Omega)$.

Proof. We apply the Transversality Theorem. Observe that G is differentiable. In fact it is analytic in h as observed in section 2.1, and the differentiability in u follows from the smoothness of f and the continuous immersion $W^{4,p} \cap W_0^{2,p}(\Omega) \subset \mathcal{C}^{2,\alpha}(\Omega)$ for some $\alpha > 0$. We compute its differential using Theorem 1 (see example 2.1 of section 2.1).

$$\begin{aligned} DG(u, i_\Omega)(\dot{u}, \dot{h}) &= \left(L(u)(\dot{u} - \dot{h} \cdot \nabla u), \right. \\ &\quad \left. \left\{ \Delta(\dot{u} - \dot{h} \cdot \nabla u) + \dot{h} \cdot N \frac{\partial \Delta u}{\partial N} \right\} \Big|_J \right). \end{aligned}$$

To verify (1) and (2), we proceed as in the proof of theorem 5. We prove that (2 β) holds showing that

$$\dim \left\{ \frac{\mathcal{R}(DG(u, h))}{\mathcal{R}\left(\frac{\partial G}{\partial u}(u, h)\right)} \right\} = \infty \text{ for all } (u, h) \in G^{-1}(0, 0).$$

Suppose, by contradiction this is not true for some $(u, h) \in G^{-1}(0, 0)$. By ‘changing the origin’ we may suppose that $h = i_\Omega$. Then, there exist $\theta_1, \dots, \theta_m \in L^p(\Omega) \times W^{2-\frac{1}{p}, p}(J)$ for all $\dot{h} \in \mathcal{C}^5(\Omega, \mathbb{R}^n)$ there exists $\dot{u} \in W^{4,p} \cap W_0^{2,p}(\Omega)$ and scalars $c_1, \dots, c_m \in \mathbb{R}$ such that

$$DG(u, i_\Omega)(\dot{u}, \dot{h}) = \sum_{i=1}^m c_i \theta_i,$$

that is,

$$L(u)(\dot{u} - \dot{h} \cdot \nabla u) = \sum_{i=1}^m c_i \theta_i^1 \tag{22}$$

$$\left\{ \Delta(\dot{u} - \dot{h} \cdot \nabla u) + \dot{h} \cdot N \frac{\partial \Delta u}{\partial N} \right\} \Big|_J = \sum_{i=1}^m c_i \theta_i^2 \tag{23}$$

where

$$L(u) = \Delta^2 + \frac{\partial f}{\partial \mu}(\cdot, u, \nabla u, \Delta u) \Delta + \frac{\partial f}{\partial y}(\cdot, u, \nabla u, \Delta u) \cdot \nabla + \frac{\partial f}{\partial \lambda}(\cdot, u, \nabla u, \Delta u). \tag{24}$$

Let $\{u_1, \dots, u_l\}$ be a basis for the kernel of $L_0(u) = L(u) \Big|_{W^{4,p} \cap W_0^{2,p}(\Omega)}$ and consider the operators

$$\mathcal{A}_{L(u)} : L^p(\Omega) \rightarrow W^{4,p} \cap W_0^{1,p}(\Omega)$$

$$\mathcal{C}_{L(u)} : W^{3-\frac{1}{p},p}(\partial\Omega) \rightarrow W^{4,p} \cap W_0^{1,p}(\Omega)$$

defined by

$$w = \mathcal{A}_{L(u)}(z) + \mathcal{C}_{L(u)}(g)$$

if $L(u)w - z$ belongs to a fixed complement of $\mathcal{R}(L_0(u))$ in $L^p(\Omega)$, $\frac{\partial w}{\partial N} = g$ on $\partial\Omega$ and $\int_{\Omega} w \phi = 0$ for all $\phi \in \mathcal{N}(L_0^*(u))$. (We proved that these operators are well defined in [9].)

Choosing $\dot{h} \in \mathcal{C}^5(\Omega, \mathbb{R}^n)$ such that $\dot{h} \equiv 0$ on $\partial\Omega - J$, we obtain from (22), that

$$\dot{u} - \dot{h} \cdot \nabla u = \sum_{i=1}^l \xi_i u_i + \sum_{i=1}^m c_i \mathcal{A}_{L(u)}(\theta_i^1) \tag{25}$$

since $\dot{u} - \dot{h} \cdot \nabla u \in W^{4,p} \cap W_0^{2,p}(\Omega)$.

Substituting (25) in (23), we obtain that $\dot{h} \cdot N \frac{\partial \Delta u}{\partial N} \Big|_J$ remains in a finite dimensional subspace when \dot{h} varies in $\mathcal{C}^5(\Omega, \mathbb{R}^n)$. Since $\dim \Omega \geq 2$ this is possible only if $\frac{\partial \Delta u}{\partial N} \equiv 0$ on J so u satisfies

$$\begin{cases} \Delta^2 u + f(\cdot, u, \nabla u, \Delta u) = 0 & \text{in } \Omega \\ u = \frac{\partial u}{\partial N} = 0 & \text{on } \partial\Omega \\ \Delta u = \frac{\partial \Delta u}{\partial N} = 0 & \text{on } J. \end{cases} \tag{26}$$

We claim that u satisfies the hypotheses of Cauchy's Uniqueness Theorem 6. Indeed, since $u \in W^{4,p}(\Omega) \cap \mathcal{C}^{2,\alpha}(\Omega)$ for some $\alpha > 0$ ($p > \frac{n}{2}$) and is a solution of the uniformly elliptic equation $\Delta^2 u + f(\cdot, u, \nabla u, \Delta u) = 0$ in Ω then

$u \in W^{4,p}(\Omega) \cap C^{4,\alpha}(\Omega)$. Furthermore, $u = \frac{\partial u}{\partial N} = \Delta u = \frac{\partial \Delta u}{\partial N} = 0$ on $J \subset \partial\Omega$ and

$$\begin{aligned} |\Delta^2 u| &\leq |f(\cdot, u, \nabla u, \Delta u)| \\ &\leq |f(\cdot, u, \nabla u, \Delta u) - f(\cdot, 0, 0, 0)| \\ &\leq \max_{\Omega} \{|Df(\cdot, u, \nabla u, \Delta u)|\} (|u| + |\nabla u| + |\Delta u|). \end{aligned}$$

We conclude that $u \equiv 0$, which gives the searched for contradiction. □

Lemma 12. *Let $\Omega \subset \mathbb{R}^n$ $n \geq 2$ be an open, connected, bounded, C^5 -regular domain and $f(x, \lambda, y, \mu)$ a C^3 real function defined in $\mathbb{R}^n \times \mathbb{R} \times \mathbb{R}^n \times \mathbb{R}$ with $f(\cdot, 0, 0, 0) \equiv 0$. Consider the map*

$$Q : A_{M,p} \times A_{M,q} \times D_M \rightarrow L^p(\Omega) \times L^q(\Omega) \times L^1(\partial\Omega)$$

defined by

$$\begin{aligned} Q(u, v, h) &= \left(h^* \Delta^2 h^{*-1} u + h^* f(\cdot, h^{*-1} u, \nabla h^{*-1} u, \Delta h^{*-1} u), \right. \\ &\quad \left. h^* L^*(h^{*-1} u) h^{*-1} v, h^* \Delta h^{*-1} u h^* \Delta h^{*-1} v \Big|_{\partial\Omega} \right) \end{aligned}$$

where $A_{M,p} = \{u \in W^{4,p} \cap W_0^{2,p}(\Omega) - \{0\} \mid \|u\| \leq M\}$ and $p^{-1} + q^{-1} = 1$ with $p > \frac{n}{2}$, $A_{M,q} = \{u \in W^{4,q} \cap W_0^{2,q}(\Omega) - \{0\} \mid \|u\| \leq M\}$, $D_M = \text{Diff}^5(\Omega) - C_M^{\partial\Omega}$, $C_M^{\partial\Omega}$ given by Lemma 11 and

$$\begin{aligned} L^*(w) &= \Delta^2 + \frac{\partial f}{\partial \mu}(\cdot, w, \nabla w, \Delta w) \Delta \\ &\quad + \left[2 \nabla \left(\frac{\partial f}{\partial \mu}(\cdot, w, \nabla w, \Delta w) \right) - \frac{\partial f}{\partial y}(\cdot, w, \nabla w, \Delta w) \right] \cdot \nabla \\ &\quad + \Delta \left[\frac{\partial f}{\partial \mu}(\cdot, w, \nabla w, \Delta w) \right] - \text{div} \left(\frac{\partial f}{\partial y}(\cdot, w, \nabla w, \Delta w) \right) \\ &\quad + \frac{\partial f}{\partial \lambda}(\cdot, w, \nabla w, \Delta w). \end{aligned}$$

Then

$$E_M = \{h \in D_M \mid (0, 0, 0) \in Q(A_{M,p} \times A_{M,q}, h)\}$$

is a meager closed subset of $\text{Diff}^5(\Omega)$.

(Observe that $L^*(w)$ is the formal adjoint of $L(w)$ defined by (24).)

Proof. We again apply the Transversality Theorem. The differentiability of Q is easy to establish, and its derivative can be computed using theorem 1 (see example 2.1)

$$\begin{aligned} &DQ(u, v, i_\Omega)(\dot{u}, \dot{v}, \dot{h}) \\ &= \left(L(u)(\dot{u} - \dot{h} \cdot \nabla u), L^*(u)(\dot{v} - \dot{h} \cdot \nabla v) + \left(\frac{\partial L^*}{\partial w}(u) \cdot v \right) (\dot{u} - \dot{h} \cdot \nabla u), \right. \\ &\quad \left. \left\{ \Delta(\dot{u} - \dot{h} \cdot \nabla u) \Delta v + \Delta u \Delta(\dot{v} - \dot{h} \cdot \nabla v) + \dot{h} \cdot N \frac{\partial}{\partial N}(\Delta u \Delta v) \right\} \Big|_{\partial\Omega} \right) \end{aligned}$$

where $\frac{\partial L^*}{\partial w}(u) \cdot v$ is the second order differential operator given by

$$\begin{aligned} \left(\frac{\partial L^*}{\partial w}(u) \cdot v\right)z &= \left(\frac{\partial^2 f}{\partial \lambda \partial \mu} v + \frac{\partial^2 f}{\partial y \partial \mu} \cdot \nabla v + \frac{\partial^2 f}{\partial \mu^2} \Delta v\right) \Delta z \\ &+ \left[2 \nabla \left(\frac{\partial^2 f}{\partial \lambda \partial \mu} v + \frac{\partial^2 f}{\partial y \partial \mu} \cdot \nabla v + \frac{\partial^2 f}{\partial \mu^2} \Delta v\right) \right. \\ &- \left.\left(\frac{\partial^2 f}{\partial \lambda \partial y} v + \frac{\partial^2 f}{\partial y^2} \nabla v + \frac{\partial^2 f}{\partial \mu \partial y} \Delta v\right)\right] \cdot \nabla z \\ &\left[\left(\frac{\partial^2 f}{\partial \lambda^2} v + \frac{\partial^2 f}{\partial \lambda \partial y} \cdot \nabla v + \frac{\partial^2 f}{\partial \lambda \partial \mu} \Delta v\right) \right. \\ &+ \Delta \left(\frac{\partial^2 f}{\partial \lambda \partial \mu} v + \frac{\partial^2 f}{\partial y \partial \mu} \cdot \nabla v + \frac{\partial^2 f}{\partial \mu^2} \Delta v\right) \\ &- \left. \operatorname{div} \left(\frac{\partial^2 f}{\partial \lambda \partial y} v + \frac{\partial^2 f}{\partial y^2} \nabla v + \frac{\partial^2 f}{\partial y \partial \mu} \Delta v\right)\right] z. \end{aligned}$$

(We have written f instead of $f(\cdot, u, \nabla u, \Delta u)$ to simplify the notation.)

The hypotheses (1) and (3) of the Transversality Theorem can be verified as in the proof of Theorem 5. We prove (2β) by showing that

$$\dim \left\{ \frac{\mathcal{R}(DQ(u, v, h))}{\mathcal{R}\left(\frac{\partial Q}{\partial(u,v)}(u, v, h)\right)} \right\} = \infty$$

for all $(u, v, h) \in Q^{-1}(0, 0, 0)$. Suppose this is not true for $(u, v, h) \in Q^{-1}(0, 0, 0)$. ‘Changing the origin’, we may assume that $h = i_\Omega$. Then, there exist $\theta_1, \dots, \theta_m \in L^p(\Omega) \times L^q(\Omega) \times L^1(\partial\Omega)$ such that for all $\dot{h} \in C^5(\Omega, \mathbb{R}^n)$ there exists $\dot{u} \in W^{4,p} \cap W_0^{2,p}(\Omega)$, $\dot{v} \in W^{4,q} \cap W_0^{2,q}(\Omega)$ and scalars $c_1, \dots, c_m \in \mathbb{R}$ such that

$$DQ(u, v, i_\Omega)(\dot{u}, \dot{v}, \dot{h}) = \sum_{i=1}^m c_i \theta_i,$$

that is,

$$L(u)(\dot{u} - \dot{h} \cdot \nabla u) = \sum_{i=1}^m c_i \theta_i^1 \tag{27}$$

$$L^*(u)(\dot{v} - \dot{h} \cdot \nabla v) + \left(\frac{\partial L^*}{\partial w}(u) \cdot v\right)(\dot{u} - \dot{h} \cdot \nabla u) = \sum_{i=1}^m c_i \theta_i^2 \tag{28}$$

and

$$\begin{aligned} \sum_{i=1}^m c_i \theta_i^3 &= \left\{ \Delta(\dot{u} - \dot{h} \cdot \nabla u) \Delta v + \Delta u \Delta(\dot{v} - \dot{h} \cdot \nabla v) \right. \\ &\left. + \dot{h} \cdot N \frac{\partial}{\partial N} (\Delta u \Delta v) \right\} \Big|_{\partial\Omega}. \end{aligned} \tag{29}$$

Let $\{u_1, \dots, u_l\}$ be a basis for the kernel of $L_0(u) = L(u)|_{W^{4,p} \cap W_0^{2,p}(\Omega)}$, $\{v_1, \dots, v_l\}$ a basis for the kernel of $L_0^*(u)$ and consider the operators

$$\mathcal{A}_{L(u)} : L^p(\Omega) \rightarrow W^{4,p} \cap W_0^{1,p}(\Omega)$$

$$\mathcal{C}_{L(u)} : W^{3-\frac{1}{p},p}(\partial\Omega) \rightarrow W^{4,p} \cap W_0^{1,p}(\Omega)$$

defined by

$$w = \mathcal{A}_{L(u)}(z) + \mathcal{C}_{L(u)}(g)$$

where $L(u)w - z$ belongs to a fixed complement of $\mathcal{R}(L_0(u))$ in $L^p(\Omega)$, $\frac{\partial w}{\partial N} = g$ on $\partial\Omega$, $\int_{\Omega} w\phi = 0$ for all $\phi \in \mathcal{N}(L_0^*(u))$ and

$$\mathcal{A}_{L^*(u)} : L^q(\Omega) \rightarrow W^{4,q} \cap W_0^{1,q}(\Omega)$$

$$\mathcal{C}_{L^*(u)} : W^{3-\frac{1}{q},q}(\partial\Omega) \rightarrow W^{4,q} \cap W_0^{1,q}(\Omega)$$

defined by

$$t = \mathcal{A}_{L^*(u)}(z) + \mathcal{C}_{L^*(u)}(g)$$

where $L^*(u)t - z$ belongs to a fixed complement of $\mathcal{R}(L_0^*(u))$ in $L^q(\Omega)$, $\frac{\partial t}{\partial N} = g$ on $\partial\Omega$ and $\int_{\Omega} t\varphi = 0$ for all $\varphi \in \mathcal{N}(L_0(u))$. (We proved that these operators are well defined in [9].)

From (27) and (28) it follows that

$$\dot{u} - \dot{h} \cdot \nabla u = \sum_{i=1}^l \xi_i u_i + \sum_{i=1}^m c_i \mathcal{A}_{L(u)}(\theta_i^1) - \mathcal{C}_{L(u)}(\dot{h} \cdot N \Delta u) \tag{30}$$

$$\begin{aligned} \dot{v} - \dot{h} \cdot \nabla v &= \sum_{i=1}^s \eta_i v_i + \sum_{i=1}^m c_i \mathcal{A}_{L^*(u)}(\theta_i^2) - \mathcal{C}_{L^*(u)}(\dot{h} \cdot N \Delta v) \\ &\quad - \mathcal{A}_{L^*(u)}\left(\left(\frac{\partial L^*}{\partial w}(u) \cdot v\right)(\dot{u} - \dot{h} \cdot \nabla u)\right). \end{aligned} \tag{31}$$

Substituting in (29), we obtain that

$$\begin{aligned} &\left\{ \dot{h} \cdot N \frac{\partial}{\partial N}(\Delta u \Delta v) - \Delta v \Delta \left(\mathcal{C}_{L(u)}(\dot{h} \cdot N \Delta u) \right) \right. \\ &\left. + \Delta u \Delta \left[\mathcal{A}_{L^*(u)}\left(\left(\frac{\partial L^*}{\partial w}(u) \cdot v\right) \mathcal{C}_{L(u)}(\dot{h} \cdot N \Delta u)\right) - \mathcal{C}_{L^*(u)}(\dot{h} \cdot N \Delta v) \right] \right\} \Big|_{\partial\Omega} \end{aligned}$$

remains in a finite dimensional space when \dot{h} varies in $\mathcal{C}^5(\Omega, \mathbb{R}^n)$, that is, the operator

$$\begin{aligned} \Upsilon(\dot{h}) &= \left\{ \dot{h} \cdot N \frac{\partial}{\partial N}(\Delta u \Delta v) - \Delta v \Delta \left(\mathcal{C}_{L(u)}(\dot{h} \cdot N \Delta u) \right) \right. \\ &\quad \left. + \Delta u \Delta \left[\mathcal{A}_{L^*(u)}\left(\left(\frac{\partial L^*}{\partial w}(u) \cdot v\right) \mathcal{C}_{L(u)}(\dot{h} \cdot N \Delta u)\right) - \mathcal{C}_{L^*(u)}(\dot{h} \cdot N \Delta v) \right] \right\} \Big|_{\partial\Omega} \end{aligned} \tag{32}$$

defined in $\mathcal{C}^5(\Omega, \mathbb{R}^n)$ is of finite range.

We proved in [9] that, if $\dim \Omega \geq 2$, a necessary condition for Υ to be of finite range is

$$\frac{\partial}{\partial N}(\Delta u \Delta v) \equiv 0 \text{ on } \partial\Omega. \tag{33}$$

Thus the functions u, v must satisfy

$$\begin{cases} \Delta^2 u - f(\cdot, u, \nabla u, \Delta u) = 0 & \text{in } \Omega \\ u = \frac{\partial u}{\partial N} = 0 & \text{on } \partial\Omega \end{cases} \tag{34}$$

$$\begin{cases} L^*(u)v = 0 & \text{in } \Omega \\ v = \frac{\partial v}{\partial N} = 0 & \text{on } \partial\Omega \end{cases} \tag{35}$$

and also

$$\Delta u \Delta v|_{\partial\Omega} = \frac{\partial}{\partial N}(\Delta u \Delta v)|_{\partial\Omega} = 0. \tag{36}$$

Let $U = \{x \in \partial\Omega \mid \Delta u(x) \neq 0\}$. Observe that U is a nonempty, since $i_\Omega \in D_M^{\partial\Omega}$ (given by Lemma 11).

By equation (36), we have $\Delta v|_U = \frac{\partial \Delta v}{\partial N}|_U \equiv 0$. Therefore $v \in W^{4,q} \cap W_0^{2,q}(\Omega)$ satisfies the hypotheses of theorem 6. Thus $v \equiv 0$ in Ω and we reach a contradiction, proving the result. \square

Theorem 13. *Generically in the set of open, connected, bounded C^4 -regular regions of \mathbb{R}^n $n \geq 2$ the solutions of (19) are all simple.*

Proof. Consider the differentiable map

$$F : B_M \times U_M \rightarrow L^p(\Omega)$$

defined by

$$F(u, h) = h^* \Delta^2 h^{*-1} u + h^* f(\cdot, h^{*-1} u, \nabla h^{*-1} u, \Delta h^{*-1} u)$$

where $B_M = \{u \in W^{4,p} \cap W_0^{2,p}(\Omega) - \{0\} \mid \|u\| \leq M\}$, $p > \frac{n}{2}$, $U_M = D_M - E_M$, D_M is the complement of the meager closed set given by Lemma 11 and E_M is the meager closed set given by Lemma 12. Observe that U_M is an open dense subset of $\text{Diff}^4(\Omega)$. We show, using the Transversality Theorem, that the set

$$\{h \in U_M \mid u \rightarrow F(u, h) \text{ has } 0 \text{ as a regular value}\}$$

is open and dense in U_M . Our result then follows by taking intersection with M varying in \mathbb{N} .

As observed in Remark 10 we may suppose, that our regions are C^5 -regular. Also by Remark 7, we only need to consider the nontrivial solutions.

As in the previous results, the verification of hypotheses (1) and (3) of the Transversality Theorem is simple, so we just show that (2α) holds.

Suppose, by contradiction, that there exists a critical point $(u, h) \in F^{-1}(0)$ and, $h = i_\Omega$. Then, there exists $v \in L^q(\Omega)$ such that

$$\int_\Omega v DF(u, i_\Omega)(\dot{u}, \dot{h}) = 0 \tag{37}$$

for all $(\dot{u}, \dot{h}) \in W^{4,p} \cap W_0^{2,p}(\Omega) \times C^5(\Omega, \mathbb{R}^n)$ where $DF(u, i_\Omega) : W^{4,p} \cap W_0^{2,p}(\Omega) \times C^5(\Omega, \mathbb{R}^n) \rightarrow L^p(\Omega)$ is given by

$$DF(u, i_\Omega)(\dot{u}, \dot{h}) = L(u)(\dot{u} - \dot{h} \cdot \nabla u)$$

with $L(u) = \Delta^2 + \frac{\partial f}{\partial \mu}(\cdot, u, \nabla u, \Delta u)\Delta + \frac{\partial f}{\partial y}(\cdot, u, \nabla u, \Delta u) \cdot \nabla + \frac{\partial f}{\partial \lambda}(\cdot, u, \nabla u, \Delta u)$.

Taking $\dot{h} = 0$ in (37), we have

$$\int_{\Omega} v L(u) \dot{u} = 0 \quad \forall \dot{u} \in W^{4,p} \cap W_0^{2,p}(\Omega),$$

that is, $v \in \mathcal{N}(L^*(u))$. Since $\partial\Omega$ is C^5 -regular and f is of class C^4 , it follows by regularity results for uniformly elliptic equations that $v \in W^{5,q}(\Omega) \cap C^{4,\alpha}(\Omega)$ for $\alpha > 0$ and satisfy

$$\begin{cases} L^*(u) v = 0 & \text{in } \Omega \\ v = \frac{\partial v}{\partial N} = 0 & \text{on } \partial\Omega. \end{cases} \tag{38}$$

If $\dot{u} = 0$ and \dot{h} varies in $C^5(\Omega, \mathbb{R}^n)$, we obtain

$$\begin{aligned} 0 &= - \int_{\Omega} v L(u)(\dot{h} \cdot \nabla u) \\ &= \int_{\Omega} \left\{ (\dot{h} \cdot \nabla u)L^*(u)v - vL(u)(\dot{h} \cdot \nabla u) \right\} \\ &= - \int_{\partial\Omega} \dot{h} \cdot N \Delta v \Delta u, \quad \forall \dot{h} \in C^5(\Omega, \mathbb{R}^n). \end{aligned}$$

Therefore, we have $\int_{\partial\Omega} \dot{h} \cdot N \Delta v \Delta u = 0 \quad \forall \dot{h} \in C^5(\Omega, \mathbb{R}^n)$ from which $\Delta v \Delta u \equiv 0$ on $\partial\Omega$. Since $i_\Omega \in U_M$, we reach a contradiction, proving the theorem. □

References

- [1] J. Hadamard *Mémoire sur le problème d'analyse relatif à des plaques élastiques encastrées*, Ouvres de J.Hadamard 2, ed C.N.R.S. Paris (1968).
- [2] D. B. Henry, *Perturbation of the Boundary in Boundary Value Problems of PDEs*, Unpublished notes, 1982, London Math. Society, Lecture Notes Series, Cambridge University Press, 2005.
- [3] L. Hormander, *Linear Partial Differential Operators*, Springer-Verlag, Grundlehren 116 (1964).
- [4] A. M. Micheletti, *Pertubazione dello spettro dell operatore de Laplace in relazione ad una variazione del campo*, Ann. Scuola Norm. Sup. Pisa 26 (1972), 151-169.
- [5] A. M. Micheletti, *Pertubazione dello spettro di un operatore ellittico di tipo variazionale, in relazione ad una variazione del campo*, Ann. Mat. Pura Appl. 4, 97 (1973), 267-281.
- [6] J. H. Ortega and E. Zuazua, *Generic simplicity of the spectrum and stabilization for a plate equation*, SIAM J. Control Optim. 39 No. 5 (2001), 1585-1614.
- [7] A. L. Pereira, *Eigenvalues of the Laplacian on symmetric regions*, NoDEA Nonlinear Differential Equations Appl. 2 No. 1 (1995), 63-109.

- [8] A. L. Pereira and M. C. Pereira, *A generic property for the eigenfunction of the Laplacian*, TMNA 20 (2002), 283-313.
- [9] A. L. Pereira and M. C. Pereira, *An extension of the method of rapidly oscillating functions*, Matemática Contemporânea 27 (2004), 225-241.
- [10] M. C. Pereira, *Generic simplicity for the eigenvalues of the Dirichlet problem for the Bilaplacian*, Elec. J. Differential Equations 114 (2004), 21p.
- [11] J. W. Rayleigh, *The Theory of Sound*, Dover, (1945).
- [12] J.C. Saut and R. Teman, *Generic properties of nonlinear boundary value problems*, Comm. Partial Differential Equations, 4 No. 3 (1979), 293-319.
- [13] J. Solkolowski *Shape sensitivity analysis of boundary optimal control problems for parabolic systems*, SIAM J. Control Optim. 26 No. 4 (1988), 763-787.
- [14] K. Uhlenbeck, *Generic Properties of Eigenfunctions*, American Journal Mathematics 98, No. 4 (1976), 1059-1078.
- [15] M. Zolésio *Velocity method and Lagrangian formulation for the computation of the shape Hessian - 1991* SIAM J. Control Optim. 29 No. 6 (1991), 1414-1442.

A.L. Pereira¹

Instituto de Matemática e Estatística da USP

R. do Matão, 1010

CEP 05508-900 – São Paulo, SP

Brazil

e-mail: alpereir@ime.usp.br

M.C. Pereira²

Escola de Artes, Ciências e Humanidades da USP

Av. Arlindo Bétio, 1000.

CEP 03828-080 – São Paulo, SP

Brazil

e-mail: marcone@usp.br

¹Research partially supported by FAPESP-SP-Brazil, grant 2003/11021-7.

²Research partially supported by CNPq – Conselho Nac. Des. Científico e Tecnológico – Brazil.

An Estimate for the Blow-up Time in Terms of the Initial Data

Julio D. Rossi

To Djairo, “El Maestro”

Abstract. We find an estimate for the blow-up time in terms of the initial data for solutions of the equation $u_t = (u^m)_{xx} + u^m$ in $\mathbb{R} \times (0, T)$ and for solutions of the problem $u_t = (u^m)_{xx}$ in $(0, \infty) \times (0, T)$ with $-(u^m)_x(0, t) = u^m(0, t)$ on $(0, T)$ with $m > 1$.

Mathematics Subject Classification (2000). 35K55, 35B40.

Keywords. Parabolic equations, blow-up time.

1. Introduction

In this short note we find an estimate for the blow-up time in terms of the initial data for solutions of the problems

$$\begin{cases} u_t = (u^m)_{xx} + u^m, & (x, t) \in \mathbb{R} \times (0, T), \\ u(x, 0) = u_0(x), & x \in \mathbb{R}, \end{cases} \quad (1.1)$$

and

$$\begin{cases} u_t = (u^m)_{xx}, & (x, t) \in (0, +\infty) \times (0, T), \\ -(u^m)_x(0, t) = u^m(0, t), & t \in (0, T), \\ u(x, 0) = u_0(x), & x \in (0, +\infty). \end{cases} \quad (1.2)$$

For both problems we assume that $m > 1$ and u_0 is nonnegative compactly supported and smooth in its positivity domain.

A remarkable and well known fact is that the solution of parabolic problems can become unbounded in finite time (a phenomena that is known as blow-up), no matter how smooth the initial data are. The study of blow-up solutions has attracted a considerable attention in recent years, see [10], [14] and the references

therein. For our problems it is known that all nontrivial solutions blow up in finite time (see [8], [14] for (1.1) and [6] for (1.2)), in the sense that the solution is defined on a maximal time interval, $[0, T)$ with $T < +\infty$ and $\lim_{t \nearrow T} \|u(\cdot, t)\|_{L^\infty} = +\infty$.

It is interesting to investigate the dependence of the blow-up time with respect to the initial data. For continuity results for the blow-up time as a function of the initial data we refer to [1], [2], [7], [9], [11], [12] and [13].

Our concern here is to obtain bounds for $T = T(u_0)$ in terms of u_0 .

Let us look first to (1.1). The main tool involved in our analysis relies on the natural scaling invariance of the problem. There exists a family (parametrized by \hat{T}) of self-similar, compactly supported, solutions of the form $u_{\hat{T}}(x, t) = (\hat{T} - t)^{-1/(m-1)}\varphi(x)$. These solutions $u_{\hat{T}}$ blow up at time \hat{T} and have initial data $u_{\hat{T}}(x, 0) = \hat{T}^{-1/(m-1)}\varphi(x)$.

Theorem 1.1. *The blow-up time T of a solution of (1.1) with initial datum u_0 verifies*

$$\min_x \left(\frac{\varphi}{u_0}\right)^{m-1} \leq T \leq \max_x \left(\frac{\varphi}{u_0}\right)^{m-1}. \tag{1.3}$$

The self-similar profile $\varphi(x)$ is a solution of $0 = (\varphi^m)''(x) + \varphi^m(x) - \frac{1}{m-1}\varphi(x)$ that is composed by a finite number of disjoint copies of a radial bump, see [3], [4]. The radial bump is explicit, it takes the form

$$\varphi(x) = (c_1 \cos^2(c_2 x))_+^a,$$

for some explicit constants a, c_1, c_2 , see [14]. Therefore the bounds provided by Theorem 1.1 are computable.

Remark that when the support of u_0 and the support of φ do not coincide then one (or both) of the estimates is immediate.

With the same approach we can prove a similar result for solutions of (1.2).

In this case there exists a unique self-similar solution of the form $u_{\hat{T}}(x, t) = (\hat{T} - t)^{-1/(m-1)}\psi(x)$.

Theorem 1.2. *The blow-up time T of a solution of (1.2) with initial datum u_0 verifies*

$$\min_x \left(\frac{\psi}{u_0}\right)^{m-1} \leq T \leq \max_x \left(\frac{\psi}{u_0}\right)^{m-1}. \tag{1.4}$$

The profile ψ is explicit and has the form

$$\psi(x) = c_1((c_2 - x)_+)^a,$$

see [5], [6].

Finally, we remark that the same approach can be also used to deal with equations involving other operators and/or source terms like $u_t = \operatorname{div}(|\nabla u|^{q-2}\nabla u) + u^{q-1}$. We only need the existence of a self-similar solution (that comes usually from a scaling invariance law) together with a comparison result.

2. Proof of the results

Proof of Theorem 1.1. To prove Theorem 1.1 we will make use of the comparison principle that holds for solutions of (1.1).

Let us begin by the lower estimate. Consider the set

$$A = \left\{ \hat{T} : u_{\hat{T}}(x, t) \geq u(x, t) \text{ for all } 0 \leq t < \hat{T} \right\}.$$

By the use of the comparison principle we have that this definition is equivalent to

$$A = \left\{ \hat{T} : \hat{T}^{-1/(m-1)}\varphi(x) = u_{\hat{T}}(x, 0) \geq u_0(x) \right\}.$$

Remark that A is closed. Assume that

$$\min_x \frac{\varphi}{u_0}$$

is positive (otherwise the estimate holds trivially) and let

$$\underline{T} = \sup A.$$

For every $\hat{T} > \underline{T}$ we have that $\hat{T} \notin A$ and then there exists a point x_0 such that

$$\hat{T}^{-1/(m-1)}\varphi(x_0) < u_0(x_0).$$

Then, every $\hat{T} > \underline{T}$ satisfies

$$\hat{T} > \left(\frac{\varphi(x_0)}{u_0(x_0)} \right)^{m-1} \geq \min_x \left(\frac{\varphi}{u_0} \right)^{m-1}.$$

Therefore, we obtain

$$\underline{T} \geq \min_x \left(\frac{\varphi}{u_0} \right)^{m-1}.$$

Now we just have to observe that by the definition of A we have $u_{\underline{T}}(x, t) \geq u(x, t)$ for every $0 \leq t < \underline{T}$. Therefore $u(x, t)$ is bounded for $0 \leq t < \underline{T}$ and hence

$$T \geq \underline{T} \geq \min_x \left(\frac{\varphi}{u_0} \right)^{m-1}.$$

This proves the lower bound in (1.3).

To prove the upper bound on T we proceed as before but in this case we have to consider the set

$$B = \left\{ \hat{T} : u_{\hat{T}}(x, t) \leq u(x, t) \text{ for all } t \leq \hat{T} \right\},$$

which is equivalent to

$$B = \left\{ \hat{T} : \hat{T}^{-1/(m-1)}\varphi(x) = u_{\hat{T}}(x, 0) \leq u_0(x) \right\}.$$

Let

$$\overline{T} = \inf B.$$

As before for any $\hat{T} < \overline{T}$ there must be a point x_1 with

$$\hat{T}^{-1/(m-1)}\varphi(x_1) > u_0(x_1).$$

That is

$$\hat{T} < \left(\frac{\varphi(x_1)}{u_0(x_1)} \right)^{m-1} \leq \max_x \left(\frac{\varphi}{u_0} \right)^{m-1}.$$

Arguing as before, we get

$$\bar{T} \leq \max_x \left(\frac{\varphi}{u_0} \right)^{m-1}.$$

By the definition of B we conclude

$$T \leq \bar{T} \leq \max_x \left(\frac{\varphi}{u_0} \right)^{m-1}.$$

This shows the upper bound in (1.3) and finishes the proof. \square

Proof of Theorem 1.2. The proof of Theorem 1.2 is completely analogous to the previous one. \square

References

- [1] P. Baras and L. Cohen. *Complete blow-up after T_{max} for the solution of a semilinear heat equation.* J. Funct. Anal. **71** (1987), 142–174.
- [2] M. Chaves and J. D. Rossi. *Regularity results for the blow-up time as a function of the initial data.* Differential Integral Equations **17** (11&12) (2004), 1263–1271.
- [3] C. Cortázar, M. del Pino and M. Elgueta. *On the blow-up set for $u_t = \Delta u^m + u^m$, $m > 1$.* Indiana Univ. Math. J. **47** (2) (1998), 541–561.
- [4] C. Cortázar, M. del Pino and M. Elgueta. *Uniqueness and stability of regional blow-up in a porous-medium equation.* Ann. Inst. H. Poincaré, Anal. Non Linéaire **19** (6) (2002), 927–960.
- [5] C. Cortázar, M. Elgueta and O. Venegas. *On the Blow-up set for $u_t = (u^m)_{xx}$, $m > 1$, with nonlinear boundary conditions.* Monatshefte Mathematik **142** (12) (2004), 67–77.
- [6] J. Davila and J. D. Rossi. *Self-similar solutions of the porous medium equation in a half-space with a nonlinear boundary condition. Existence and symmetry.* J. Math. Anal. Appl. **296** (2004), 634–649.
- [7] C. Fermanian Kammerer, F. Merle, and H. Zaag. *Stability of the blow-up profile of non-linear heat equations from the dynamical system point of view.* Math. Ann. **317** (2000), 195–237.
- [8] V. A. Galaktionov. *Boundary value problems for the nonlinear parabolic equation $u_t = \Delta u^{\sigma+1} + u^\beta$.* Differ. Equations. **17** (1981), 551–555.
- [9] V. A. Galaktionov and J. L. Vazquez. *Continuation of blow-up solutions of nonlinear heat equations in several space dimensions.* Comm. Pure Appl. Math. **50** (1997), 1–67.
- [10] V. A. Galaktionov and J. L. Vázquez. *The problem of blow-up in nonlinear parabolic equations.* Discrete Contin. Dynam. Systems A **8** (2002), 399–433.

- [11] P. Groisman, J. D. Rossi and H. Zaag. *On the dependence of the blow-up time with respect to the initial data in a semilinear parabolic problem*. Comm. Partial Differential Equations **28** (3&4) (2003), 737–744.
- [12] M. A. Herrero and J. J. L. Velazquez. *Generic behaviour of one-dimensional blow up patterns*. Ann. Scuola Norm. Sup. di Pisa **XIX** (3) (1992), 381–450.
- [13] P. Quittner. *Continuity of the blow-up time and a priori bounds for solutions in superlinear parabolic problems*. Houston J. Math **29** (3) (2003), 757–799.
- [14] A. Samarskii, V. A. Galaktionov, S. P. Kurdyumov and A. P. Mikhailov. *Blow-up in quasilinear parabolic equations*. Walter de Gruyter, Berlin, (1995).

Julio D. Rossi

Departamento de Matemática

FCEyN., UBA (1428)

Buenos Aires

Argentina

and

Consejo Superior de Investigaciones Científicas (CSIC)

Serrano 123

Madrid

Spain

e-mail: jrossi@dm.uba.ar

Lorentz Spaces and Nonlinear Elliptic Systems

Bernhard Ruf

Dedicated to Djairo on his 70th birthday

Abstract. In this paper we study the following system of semilinear elliptic equations:

$$\begin{cases} -\Delta u &= g(v), & \text{in } \Omega, \\ -\Delta v &= f(u), & \text{in } \Omega, \\ u = 0 \text{ and } v = 0 &, & \text{on } \partial\Omega, \end{cases}$$

where Ω is a bounded domain in \mathbb{R}^N , and $f, g \in C(\mathbb{R})$ are superlinear nonlinearities. The natural framework for such systems are Sobolev spaces, which give in most cases an adequate answer concerning the “maximal growth” on f and g such that the problem can be treated variationally. However, in some limiting cases the Sobolev imbeddings are not sufficiently fine to capture the true maximal growth. We consider two cases, in which working in *Lorentz spaces* gives better results.

a) $N \geq 3$: we assume that $g(s) = s^p$, with $p + 1 = \frac{N}{N-2}$, which means that p lies on the asymptote of the so-called “critical hyperbola”, see below. In the Sobolev space setting there exist several different variational formulations, which (surprisingly) yield different maximal growths for f . We show that this is due to the non-optimality of the Sobolev embeddings theorems; indeed, by using instead a Lorentz space setting (which gives optimal embeddings), the different maximal growths disappear: we then infer that the critical growth for f is $f(u) \sim e^{|u|^{N/(N-2)}}$.

b) $N = 2$: in two dimensions the maximal growth is of exponential type, given by Trudinger-Moser type inequalities. Using the Lorentz space setting, we show that for $f \sim e^{|s|^p}$ and $g \sim e^{|s|^q}$ we have maximal (critical) growth for

$$\frac{1}{p} + \frac{1}{q} = 1,$$

which is an analogue of the critical hyperbola in dimensions $N \geq 3$.

1. Introduction

We consider the system of equations

$$\begin{cases} -\Delta u = g(v) , & \text{in } \Omega \\ -\Delta v = f(u) , & \text{in } \Omega \\ u|_{\partial\Omega} = v|_{\partial\Omega} = 0 \end{cases} \tag{1}$$

where $\Omega \subset \mathbb{R}^N$ is a bounded domain, and the nonlinearities f and g satisfy:

- f is continuous and superlinear;
- g is of the form $g(s) = s^p$
- (here and in what follows, we write $s^p := \text{sgn}(s)|s|^p$).

Dimension $N \geq 3$:

It is known, see de Figueiredo–Felmer [5] and Hulshof–van der Vorst [11], that for the “model problem”

$$f(s) = s^q , \quad q > 1 , \quad \text{and} \quad g(s) = s^p , \quad p > 1 ,$$

“critical growth” is given by the so-called “critical hyperbola”

$$\frac{1}{p+1} + \frac{1}{q+1} = 1 - \frac{2}{N} . \tag{2}$$

For exponents (p, q) lying on this curve one finds the typical phenomena of non-compactness, and non-existence of solutions was proved in [18], [12], using Pohozaev type arguments, while for exponents (p, q) below this curve one has compactness, and the existence of solutions was proved in [5], [11].

On the other hand, in [8] it was shown that for $g(s) = s^p$ with $0 < p < \frac{2}{N-2}$, i.e. when $p + 1$ is on the left of the asymptote $\frac{N}{N-2}$ of the hyperbola, then the nonlinearity $f(s)$ may have an arbitrary growth.

In this paper we consider the case $p + 1 = \frac{N}{N-2}$, that is $p + 1$ lies on the asymptote of the critical hyperbola; we consider

$$(PN) \quad \begin{cases} -\Delta u = v^{\frac{2}{N-2}} , & \text{in } \Omega \\ -\Delta v = f(u) , & \text{in } \Omega \\ u|_{\partial\Omega} = v|_{\partial\Omega} = 0 \end{cases} \quad \Omega \subset \mathbb{R}^3 .$$

We will see that then the maximal admissible growth of the nonlinearity $f(s)$ is of exponential type and is determined by Trudinger–Moser type inequalities. However, we encounter the following somewhat surprising situation: There exist several different Sobolev space settings to treat this system. All these approaches yield *the same critical hyperbola*, and thus seem to be equivalent; however, in the limiting case $p + 1 = \frac{N}{N-2}$, these different approaches yield different (in fact, a continuum of) “critical growths” for f , in the form

$$f(s) \sim e^{|s|^{\frac{N}{N-t}}} , \quad t \in (0, 2) .$$

It was pointed out to us by H. Brezis that this may be due to the fact that Sobolev’s inequalities can be slightly improved by working in Lorentz spaces, see [3]. This improvement is minuscule, and has no effect for the “critical hyperbola”; but for the limiting case, as observed in [3], the Trudinger–Moser inequality has a “magnifying effect”. Indeed, we will prove by using a Lorentz space setting that the varying critical growths for f mentioned above become one, namely:

Theorem 1.1. *The maximal growth for the nonlinearity $f(s)$ in system (PN) is:*

$$f(s) \sim e^{|s|^{\frac{N}{N-2}}} .$$

Dimension $N = 2$:

In dimension $N = 2$ one sees from (2) that *any polynomial growth* for f and g is admitted, and hence the critical hyperbola is not defined. One expects that, as for the scalar equation (see [2], [9]), the maximal growths are of exponential type, given by Trudinger–Moser type inequalities. Indeed, considering the associated functional $J(u, v)$ on the space $H_0^1(\Omega) \times H_0^1(\Omega)$ it was proved in [6] that then the maximal growth for both nonlinearities is the classical Trudinger–Moser growth

$$f(s) \sim e^{|s|^2} , \quad g(s) \sim e^{|s|^2} .$$

Also in this case one expects that by working in different spaces one can obtain a “critical curve”, containing nonlinearities f and g with different maximal growths. Indeed, using again a Lorentz space setting (i.e. considering $J(u, v)$ on the product of two different Sobolev–Lorentz spaces), we will prove an analogue of the critical hyperbola:

Theorem 1.2. *Consider system (1), with $\Omega \subset \mathbb{R}^2$ bounded, and consider nonlinearities of the asymptotic form*

$$f(s) \sim e^{|s|^p} \quad \text{and} \quad g(s) \sim e^{|s|^q} .$$

Then the maximal growths for f and g for system (1) is given for $p > 1$ and $q > 1$ satisfying

$$\frac{1}{p} + \frac{1}{q} = 1 .$$

2. One functional — different Sobolev space settings

In this section we consider system (PN), $N \geq 3$. We will describe three different Sobolev space settings, and will show that they all yield the critical hyperbola (2).

2.1. The $W^{1,\alpha}$ setting

The natural functional associated to system (1) is

$$J(u, v) = \int_{\Omega} \nabla u \nabla v dx - \int_{\Omega} (F(u) + G(v)) dx , \tag{3}$$

with $F(s) = \int_0^s f(t)dt$ and $G(s) = \int_0^s g(t)dt$, and a natural space to consider this functional is the Sobolev space $H_0^1(\Omega) \times H_0^1(\Omega)$. In order to have a well-defined C^1 -functional on this space, one has to impose the *growth restrictions*:

$$|F(s)| \leq c|s|^{2^*} + d, \quad |G(s)| \leq c|s|^{2^*} + d, \quad \text{where } 2^* = \frac{2N}{N-2}.$$

However, if we consider the asymptotic case where $G(s) \sim |s|^{\frac{N}{N-2}}$, these conditions are too loose for $G(s)$, and they are too restrictive for $F(s)$, where we look for a larger growth limitation of possibly exponential type.

As proposed in [7], the functional

$$J(u, v) = \int_{\Omega} \nabla u \nabla v - \frac{N-2}{N} \int_{\Omega} |v|^{\frac{N}{N-2}} - \int F(u)$$

can be defined on the space $W_0^{1,\alpha}(\Omega) \times W_0^{1,\beta}(\Omega)$, with $\frac{1}{\alpha} + \frac{1}{\beta} = 1$, by estimating

$$\left| \int_{\Omega} \nabla u \nabla v \right| \leq \|\nabla\|_{\alpha} \|\nabla v\|_{\beta}.$$

To guarantee that the second term in the functional is well-defined we need to require

$$W^{1,\alpha}(\Omega) \subset L^{\frac{N}{N-2}}(\Omega)$$

which yields the condition

$$\frac{N}{N-2} = \alpha^* = \frac{N\alpha}{N-\alpha} \iff \frac{N}{N-1} = \alpha.$$

By $\frac{1}{\alpha} + \frac{1}{\beta} = 1$ we obtain $\beta = N$, and we then look for the largest possible growth $\phi(s)$ such that $\int_{\Omega} \phi(u)dx$ is finite for $u \in W^{1,\beta}(\Omega) = W^{1,N}(\Omega)$. Indeed, by Pohozaev [14] and Trudinger [17] we have

$$W^{1,N}(\Omega) \subset L_{\phi}(\Omega)$$

where L_{ϕ} is the Orlicz space with the corresponding N -function

$$\phi(s) = e^{|s|^{\frac{N}{N-1}}},$$

see also Adams, [1]. Thus, in this case we obtain the maximal admissible (= critical?) growth for the primitive $F(s)$:

$$F(s) \sim e^{|s|^{\frac{N}{N-1}}}.$$

2.2. The H^s setting

We recall that the critical hyperbola (2) was originally obtained (see [11], [5]) by working in *fractional Sobolev spaces* $H^s(\Omega)$, given by functions u whose “fractional derivative of order s ” lies in L^2 . These spaces can be defined via interpolation or Fourier series, see Adams [1]. Considering the operators $A^s : H^s(\Omega) \rightarrow L^2(\Omega)$

which associate to $u \in H^s$ its fractional derivative of order s , one can then define the functional

$$I(u, v) = \int_{\Omega} A^s u A^t v - \int_{\Omega} G(u) - \int_{\Omega} F(v) , \quad \text{with } s + t = 2 , \tag{4}$$

on the space $H^s(\Omega) \times H^t(\Omega)$. Critical points of $I(u, v)$ correspond again to solutions of system (1). Since $H^s \subset L^{\frac{2N}{N-2s}}$, this gives for $F(v) = |v|^{p+1}$ and $G(u) = |u|^{q+1}$ the growth conditions

$$p + 1 = \frac{2N}{N - 2s} , \quad q + 1 = \frac{2N}{N - 2t} ,$$

which yields

$$\frac{1}{p + 1} + \frac{1}{q + 1} = \frac{N - 2s}{2N} + \frac{N - 2t}{2N} = 1 - \frac{2}{N} ,$$

i.e. again the critical hyperbola.

2.3. A “mixed approach”

We now combine the two methods, i.e. we consider the functional $I(u, v)$ in (4) on the space

$$W^{s,\alpha}(\Omega) \times W^{t,\beta}(\Omega) , \quad s + t = 2 , \quad \frac{1}{\alpha} + \frac{1}{\beta} = 1 .$$

By the embeddings $W^{s,\alpha} \subset L^{\frac{\alpha N}{N-\alpha s}}$, this gives the following conditions for $p + 1$ and $q + 1$:

$$p + 1 = \frac{\alpha N}{N - s\alpha} , \quad q + 1 = \frac{\beta N}{N - t\beta} ,$$

and hence we obtain again the critical hyperbola:

$$\frac{1}{p + 1} + \frac{1}{q + 1} = \frac{1}{\alpha} - \frac{s}{N} + \frac{1}{\beta} - \frac{t}{N} = 1 - \frac{2}{N}$$

For the asymptotic “borderline case” (PN) we now get:

$$\frac{N}{N - 2} = p + 1 = \frac{\alpha N}{N - s\alpha}$$

which implies

$$\alpha = \frac{N}{N - (2 - s)} ,$$

and hence by $\frac{1}{\alpha} + \frac{1}{\beta} = 1$

$$\beta = \frac{N}{2 - s} = \frac{N}{t} .$$

The space $W_0^{1,\beta}(\Omega) = W_0^{t, \frac{N}{t}}(\Omega)$ is a limiting Sobolev case, and by Strichartz [16] we have

$$W_0^{t,\beta}(\Omega) = W_0^{t, \frac{N}{t}}(\Omega) \subset L_{\phi}(\Omega)$$

with

$$\phi(r) = e^{|r|^{\frac{N}{N-t}}} , \quad 0 < t < 2 .$$

Thus, the maximal growth for F is $F(u) \sim e^{|u|^{\frac{N}{N-t}}}$, $0 < t < 2$, i.e. we have found a variable “critical growth”, depending on the choice of t !

We emphasize once more that we have found for system (PN) , by using different variational settings, different maximal growths for the nonlinearity f . This is of course somewhat disturbing. We now turn to

3. The Lorentz space approach

We now change from Sobolev space settings to *Lorentz spaces*.

3.1. Lorentz spaces

We recall the definition of a Lorentz space: For $\phi : \Omega \rightarrow \mathbb{R}$ a measurable function, we denote by

$$\mu_\phi(t) = |\{x \in \Omega : \phi(x) > t\}|, \quad t \geq 0,$$

its *distribution function*. The *decreasing rearrangement* $\phi^*(s)$ of ϕ is defined by

$$\phi^*(s) = \sup\{t > 0 ; \mu_\phi(t) > s\}, \quad 0 \leq s \leq |\Omega| .$$

The Lorentz space $L(p, q)$ is given as follows: $\phi \in L(p, q)$, $1 < p < \infty$, $1 \leq q < \infty$, if

$$\|\phi\|_{p,q} = \left(\int_0^\infty [\phi^*(t)t^{1/p}]^q \frac{dt}{t} \right)^{1/q} < +\infty.$$

We recall (see Adams [1]):

- 1) $L(p, p) = L^p, 1 < p < +\infty$.
- 2) The following inclusions hold for $1 < q < p < r < \infty$:

$$L^r \subset L(p, 1) \subset L(p, q) \subset L(p, p) = L^p \subset L(p, r) \subset L^q.$$

- 3) Hölder inequality:

$$\left| \int_\Omega f g dx \right| \leq \|f\|_{p,q} \|g\|_{p',q'}, \quad \text{where } p' = \frac{p}{p-1}, \quad q' = \frac{q}{q-1}.$$

Furthermore, we recall the following embedding results:

Theorem A. *Suppose that $1 \leq p < N$, and that $\nabla u \in L(p, q)$; then $u \in L(p^*, q)$, where $p^* = \frac{Np}{N-p}$ and $1 \leq q < \infty$.*

For the next theorem, see H. Brezis [3]:

Theorem B. *Suppose that $u \in W^{j,p}$, with $1 \leq p < \frac{N}{j}$; then $u \in L(p^*, p)$ with $\frac{1}{p^*} = \frac{1}{p} - \frac{j}{N}$.*

This improves Sobolev’s theorem, which gives $u \in L^{p^*} = L(p^*, p^*)$, which is a larger space than $L(p^*, p)$.

The following refinement of Trudinger’s result (see H. Brezis and S. Wainger [4], H. Brezis [3]) is of particular importance for our considerations.

Theorem C. *Assume $\nabla u \in L(N, q)$ for some $1 < q < \infty$. Then $e^{|u|^{\frac{q}{q-1}}} \in L^1$. Furthermore, there exists $\theta > 0$ (depending only on q) and $c > 0$ (depending only on $m(\Omega)$) such that*

$$\int_{\Omega} e^{\theta|u|^{\frac{q}{q-1}}} \leq c, \quad \forall \|\nabla u\|_{N,q} \leq 1.$$

We make the following

Definition *Let $\Omega \subset \mathbb{R}^N$ be a bounded domain. Assume that $1 < p < \infty, 1 < q < \infty$, and set*

$$W_0^1 L(p, q)(\Omega) = c l\{u \in C_0^\infty(\Omega) : \|\nabla u\|_{p,q} < \infty\}.$$

On $W_0^1 L(p, q)$ we have the norm

$$\|u\|_{1;p,q} := \|\nabla u\|_{p,q}$$

with which $W_0^1 L(p, q)$ becomes a reflexive Banach space.

3.2. The functional in the Lorentz space setting

We consider again the functional

$$J(u, v) = \int_{\Omega} \nabla u \nabla v dx - \int_{\Omega} F(u) - \frac{N-2}{N} \int_{\Omega} |v|^{\frac{N}{N-2}} dx. \tag{5}$$

We want to consider the term $\int_{\Omega} \nabla u \nabla v dx$ on a product of Lorentz spaces, i.e. we want to estimate

$$|\int_{\Omega} \nabla u \nabla v dx| \leq \|\nabla v\|_{L(p,q)} \|\nabla u\|_{L(p',q')},$$

where we determine p, q and p', q' such that the last term in $J(u, v)$ is well defined, i.e.

$$v \in L^{\frac{N}{N-2}} = L(\frac{N}{N-2}, \frac{N}{N-2}).$$

By Theorem A we obtain the following condition for p :

$$\frac{N}{N-2} = p^* = \frac{Np}{N-p},$$

and hence

$$p = \frac{N}{N-1}, \quad q = \frac{N}{N-2}.$$

Thus, we have to impose

$$\nabla v \in L(\frac{N}{N-1}, \frac{N}{N-2}),$$

Next, we calculate

$$p' = \frac{p}{p-1} = N \quad \text{and} \quad q' = \frac{q}{q-1} = \frac{N}{2},$$

and hence we get the condition

$$\nabla u \in L(p', q') = L(N, \frac{N}{2}) .$$

By Theorem C above we now find for $\nabla u \in L(N, \frac{N}{2})$ that $e^{|u|^{\frac{N}{N-2}}} \in L^1(\Omega)$.

Thus we have

Theorem 3.1. *The functional*

$$J(u, v) = \int_{\Omega} \nabla u \nabla v dx - \int_{\Omega} F(u) - \frac{N-2}{N} \int_{\Omega} |v|^{\frac{N}{N-2}} dx$$

is well defined on the space

$$W_0^1 L(\frac{N}{N-1}, \frac{N}{N-2})(\Omega) \times W_0^1 L(N, \frac{N}{2})(\Omega) ,$$

and the maximal growth for $F(u)$ is given by

$$F(u) \sim e^{|u|^{\frac{N}{N-2}}} .$$

4. $N = 2$: an exponential “critical hyperbola”

In this section we assume that $\Omega \subset \mathbb{R}^2$ and consider again the system

$$(P2) \quad \begin{cases} -\Delta u = g(v) , & \text{in } \Omega \\ -\Delta v = f(u) , & \text{in } \Omega \\ u = 0 \text{ and } v = 0 , & \text{on } \partial\Omega . \end{cases}$$

For the scalar equation $-\Delta u = f(u)$ in Ω , $u = 0$ on $\partial\Omega$, critical growth is given by the Trudinger–Moser inequality, i.e. $F(u) \sim e^{|u|^2}$. For the system, we look for an analogue of the critical hyperbola. By considering the functional on the space $H_0^1 \times H_0^1$ one sees that the nonlinearities $G(v) \sim e^{|v|^2}$ and $F(u) \sim e^{|u|^2}$ lie on this “critical curve”. We assume that $F(t)$ and $G(t)$ have “exponential polynomial growth”, i.e.

$$F(t) \sim e^{|t|^p} , \text{ and } G(t) \sim e^{|t|^q} , \text{ for some } 1 < p, q < +\infty .$$

We prove:

Theorem 4.1. *Let $\Omega \subset \mathbb{R}^2$ be a bounded domain. Then we have an “exponential critical curve” given by*

$$(F(s), G(s)) = (e^{|s|^p}, e^{|s|^q}) , \text{ with } \frac{1}{p} + \frac{1}{q} = 1 .$$

Proof. We consider the functional

$$J(u, v) = \int_{\Omega} \nabla u \nabla v dx - \int_{\Omega} F(u) - \int_{\Omega} G(v) , \tag{6}$$

and we want to consider the term $\int_{\Omega} \nabla u \nabla v dx$ on a product of Lorentz spaces. Note that if we choose $W^1 L(p, q)$ with $p > 2$, and hence $0 < p' < 2$, then $W^1(p, q) \subset L^\infty$

and $W^1L(p', q') \subset L((p')^*, q')$ with $(p')^* < \infty$. This suggests the choice of the Sobolev–Lorentz spaces $W^1(2, q)$ and $W^1L(2, q')$, i.e. we want to estimate, using the Hölder inequality on Lorentz spaces:

$$\left| \int_{\Omega} \nabla u \nabla v dx \right| \leq \|\nabla u\|_{L(2,q)} \|\nabla v\|_{L(2,q')}, \quad \frac{1}{q} + \frac{1}{q'} = 1 .$$

By Theorem C we then have

$$e^{|u|^{\frac{q}{q-1}}} \in L^1 \quad \text{and} \quad e^{|v|^{\frac{q'}{q'-1}}} \in L^1 ,$$

and thus the maximal growth allowed for $F(s) = \int_0^s f(t)dt$ and $G(s) = \int_0^s g(t)dt$ is given by

$$F(u) \sim e^{|u|^p}, \quad p = q' = \frac{q}{q-1}, \quad \text{and} \quad G(v) \sim e^{|v|^q} . \quad \square$$

5. Critical and subcritical growth

5.1. Some considerations

Critical growth for (scalar) elliptic equations is connected with several phenomena: for subcritical growth one has compactness and hence existence of solutions; at critical growth, there is loss of compactness, and one finds concentration behavior and nonexistence of solutions.

Turning to elliptic systems, we have seen that in $N \geq 3$ critical growth is given by the “critical hyperbola”, which is obtained by the embeddings $H^s \times H^t \subset L^{q+1} \times L^{p+1}$, see [11], [5], or alternatively by the embeddings $W^{1,\alpha} \times W^{1,\beta} \subset L^{q+1} \times L^{p+1}$, see [7]. In analogy to the situation for the scalar equation, we find

- for subcritical growth one has compactness, and the existence of solutions can be obtained via variational methods; we point out that additional difficulties arise due to the strong indefiniteness of the functional, see [11], [5];
- for critical growth, i.e. for nonlinearities which lie on the critical hyperbola, loss of compactness is known [10], and nonexistence of solutions for nonlinearities on the hyperbola has been proved using Rellich-type inequalities, see [12].

In section 3, Theorem 3.1, we have considered the system (PN) corresponding to the limiting case on the asymptote of the critical hyperbola, and we have seen that then the maximal growths are obtained by the limiting embedding of Lorentz–Sobolev spaces

$$W_0^1L\left(\frac{N}{N-1}\right) \times W_0^1L\left(N, \frac{N}{2}\right) \subset L^{\frac{N}{N-2}} \times L_{e^{|s|^{\frac{N}{N-2}}}} . \quad (7)$$

Similarly, in section 4, Theorem 4.1 we have seen that for system (P2) the limiting embeddings are given by

$$W_0^1L(2, q) \times W_0^1L(2, q') \subset L_{e^{|s|^{q'}}} \times L_{e^{|s|^q}}, \quad \frac{1}{q} + \frac{1}{q'} = 1 . \quad (8)$$

In the next section we will prove existence results for systems which are subcritical with respect to the embeddings in (7) and (8). The behavior of the critical cases remains open.

5.2. Existence of solutions for subcritical equations

In this section we prove the existence of solutions for systems (PN) and (P2) in the “subcritical case”. In the case of (PN) we restrict ourselves to dimension $N = 3$ (i.e. to (P3)), since for $N \geq 4$ the nonlinearity $v^{\frac{2}{N-2}}$ becomes *sublinear*, which requires different variational methods than the ones adopted here, see e.g. [8]. As mentioned, we consider the functional

$$J(u, v) = \int_{\Omega} \nabla u \nabla v - \int_{\Omega} F(u) - \int_{\Omega} G(v) \tag{9}$$

on the space

$$E_3 = W_0^1 L(\frac{3}{2}, 3) \times W_0^1 L(3, \frac{3}{2}) , \quad \text{if } \Omega \subset \mathbb{R}^3, \text{ for system (P3)}$$

and on the space

$$E_2 = W_0^1 L(2, q) \times W_0^1 L(2, q') , \quad \text{if } \Omega \subset \mathbb{R}^2, \text{ for system (P2)} .$$

We point out that we are in a “subcritical situation” if *one of* the nonlinearities is subcritical with respect to these embeddings. We will assume in both cases that $G(s)$ is subcritical; in case (P3) this is justified by the observation that F subcritical means that we are “on the left” of the critical hyperbola, and then we can refer to [8]. On the other hand, in the case (P2) the situation is symmetric with respect to f and g , and we may assume without restricting generality that g is subcritical.

We make the following assumptions on f and g (our aim is to give simple assumptions, at the expense of greater generality):

- A1) f and g are continuous functions, with $f(s) = o(s)$ and $g(s) = o(s)$ near the origin.
- A2) There exist constants $\mu > 2, \nu > 2$ and $s_0 > 0$ such that

$$0 < \mu F(s) \leq s f(s) \quad \text{and} \quad 0 < \nu G(s) \leq s g(s) , \quad \forall |s| \geq s_0 .$$

- A3) There exist constants $s_1 > 0$ and $M > 0$ such that

$$0 < G(s) \leq M g(s) \quad \text{for all } s \geq s_0 .$$

We remark that this assumption implies that g has at least exponential growth; in fact, as is easily seen, it also implies the assumption A2) for g .

- A4) f has at most critical growth, i.e. there exist constants a_1, a_2 and d such that

$$f(s) \leq a_1 + a_2 |s|^2 , \quad \text{in the case (P3)}$$

$$f(s) \leq a_1 + a_2 e^{d|s|^{q'}} , \quad q' = \frac{q}{q-1} , \quad \text{in the case (P2)} .$$

A5) g is subcritical, i.e. for all $\delta > 0$ holds (see [9])

$$\lim_{|s| \rightarrow \infty} \frac{g(s)}{e^{\delta|s|^3}} = 0, \text{ in the case (P3)}$$

$$\lim_{|s| \rightarrow \infty} \frac{g(s)}{e^{\delta|s|^q}} = 0, \text{ in the case (P2) .}$$

Examples.

Case (P3): $F(s) = |s|^3, G(s) = e^{|s|^\beta} - 1 - |s|^\beta$, with $0 < \beta < 3$;

Case (P2): $F(s) = e^{|s|^{q'}} - 1 - |s|^{q'}, G(s) = e^{|s|^\beta} - 1 - |s|^\beta$, with $1 < \beta < q$.

Theorem 5.1. *Under assumptions A1)–A5), systems (P3) and (P2) have a non-trivial positive (weak) solution $(u, v) \in E_3$, or $(u, v) \in E_2$, respectively.*

Proof. The proof follows ideas from [6] and [7].

We note that the functional J given in (6) is strongly indefinite, being unbounded from above and below on infinite dimensional subspaces. If working on a Hilbert space H , one can find suitable subspaces $H^+ \oplus H^- = H$ such that $J|_{H^+}$ is positive definite and $J|_{H^-}$ is negative definite near the origin. Since we are working on the Banach space E , the subspaces H^+, H^- have to be replaced by infinite dimensional manifolds. We proceed in several steps:

a) The tilde map

Consider the bilinear map $\int_{\Omega} \nabla u \nabla v dx$ on the space $W_0^1 L(p, q) \times W_0^1 L(p', q')$, where $p' = \frac{p}{p-1}$ and $q' = \frac{q}{q-1}$. We recall that

$$p = \frac{3}{2}, q = 3 \quad \text{and} \quad p' = 3, q' = \frac{3}{2} \quad \text{if } N = 3$$

$$p = 2, 1 < q < \infty \quad \text{and} \quad p' = 2, 1 < q' < \infty \quad \text{if } N = 2.$$

For $u \in W_0^1 L(p, q)$ denote with $\tilde{u} \in W_0^1 L(p', q')$ the unique element such that

$$\sup_{\{v \in W_0^1 L(p', q') : \|\nabla v\|_{p', q'} = \|\nabla u\|_{p, q}\}} \int_{\Omega} \nabla u \nabla v dx = \int_{\Omega} \nabla u \nabla \tilde{u} dx = \|\nabla u\|_{p, q} \|\nabla \tilde{u}\|_{p', q'}$$

and hence

$$\int_{\Omega} \nabla u \nabla \tilde{u} dx = \|\nabla u\|_{p, q}^2 = \|\nabla \tilde{u}\|_{p', q'}^2. \tag{10}$$

The existence and uniqueness of \tilde{u} follows from the reflexivity and convexity of $W_0^1 L(p, q)$, see [7].

We can thus define the “tilde-map”: $W_0^1 L(p, q) \rightarrow W_0^1 L(p', q'), u \mapsto \tilde{u}$. This map is clearly continuous; it is nonlinear, but positively homogeneous: $\tilde{\rho u} = \rho \tilde{u}$, for all $\rho \geq 0$.

On the product space $E = W_0^1 L(p, q) \times W_0^1 L(p', q')$ we can now define two continuous submanifolds

$$E^+ = \{(u, \tilde{u}) : u \in W_0^1 L(p, q)\}, \quad E^- = \{(u, -\tilde{u}) : u \in W_0^1 L(p, q)\}.$$

As remarked in [7], the nonlinear manifolds E^+ and E^- have a *linear* structure with respect to the following notion of *tilde-sum*:

$$(u, \tilde{v}) \tilde{+} (y, \tilde{z}) := (u + y, \widetilde{v + z}) ,$$

and one has

$$E = E^+ \tilde{\oplus} E^- , \quad \text{with norm } \|w\|_E^2 = \|(u, \tilde{v})\|_E^2 = \|\nabla u\|_{p,q}^2 + \|\nabla \tilde{v}\|_{p',q'}^2 .$$

b) Linking structure

Next, we verify that the functional J has a linking structure in $(0, 0)$:

Using A1) and A4) one estimates, for given $\epsilon > 0$,

$$F(s) \leq \epsilon s^2 + c|s|^3 , \quad G(s) \leq \epsilon s^2 + c|s|^3 e^{|s|} , \quad \text{in case (P3)}$$

$$F(s) \leq \epsilon s^2 + c|s|^3 e^{d|s|^{q'}} , \quad G(s) \leq \epsilon s^2 + c|s|^3 e^{|s|^{q'}} , \quad \text{in case (P2)} .$$

Claim 1: There exist $\rho > 0$ and $\sigma > 0$ such that $J(u, \tilde{u}) \geq \sigma$ for $\|(u, \tilde{u})\|_E = \rho$.

Indeed, using (10) and

$$J(u, \tilde{u}) = \int_{\Omega} \nabla u \nabla \tilde{u} - \int_{\Omega} F(u) - \int_{\Omega} G(\tilde{u})$$

$$\geq \begin{cases} \frac{1}{2} \|\nabla u\|_{\frac{3}{2},3}^2 - \epsilon \int_{\Omega} |u|^2 - c \int_{\Omega} |u|^3 + \frac{1}{2} \|\nabla \tilde{u}\|_{3,\frac{3}{2}}^2 \\ \quad - \epsilon \int_{\Omega} |\tilde{u}|^2 - c \|\tilde{u}\|_6^3 \left(\int_{\Omega} e^{2d|\tilde{u}|^3} \right)^{1/2}, & \text{if } N = 3 \\ \frac{1}{2} \|\nabla u\|_{2,q}^2 - \epsilon \int_{\Omega} |u|^2 - c \|u\|_6^3 \left(\int_{\Omega} e^{2|u|^{q'}} \right)^{1/2} \\ \quad + \frac{1}{2} \|\nabla \tilde{u}\|_{2,q'}^2 - \epsilon \int_{\Omega} |\tilde{u}|^2 - c \|\tilde{u}\|_6^3 \left(\int_{\Omega} e^{2|\tilde{u}|^q} \right)^{1/2}, & \text{if } N = 2. \end{cases}$$

Now, we use that for $N = 3$ we have by Theorem A

$$\|u\|_3 \leq d_1 \|\nabla u\|_{\frac{3}{2},3} , \quad \|\tilde{u}\|_6 \leq d_2 \|\nabla \tilde{u}\|_{3,\frac{3}{2}}$$

and by Theorem 3, [4], there exists a $\theta > 0$ such that

$$\int_{\Omega} e^{2|\tilde{u}|^3} \leq c , \quad \text{if } \|\tilde{u}\|_{3,\frac{3}{2}} \leq \theta ,$$

and similarly for $N = 2$:

$$\|u\|_6 \leq d_3 \|\nabla u\|_{2,q} \quad \text{and} \quad \int_{\Omega} e^{2|u|^{q'}} \leq c , \quad \text{if } \|\nabla u\|_{2,q} \leq \theta_1$$

$$\|\tilde{u}\|_6 \leq d_4 \|\nabla \tilde{u}\|_{2,q'} \quad \text{and} \quad \int_{\Omega} e^{2|\tilde{u}|^q} \leq c , \quad \text{if } \|\nabla \tilde{u}\|_{2,q'} \leq \theta_2 .$$

With these estimates the claim follows easily.

Next, fix $e_1 \in W^1L(p, q)$ and $\tilde{e}_1 \in W^1L(p', q')$ with $\|\nabla e_1\|_{p,q} = \|\nabla \tilde{e}_1\|_{p',q'} = 1$, and let

$$Q = \{r(e_1, \tilde{e}_1) \tilde{+} w ; w \in E^- , \|w\|_E \leq R_0, 0 \leq r \leq R_1\}.$$

Claim 2: There exist $R_0, R_1 > 0$ such that $I(z) \leq 0$, $\forall z \in \partial Q$, where ∂Q denotes the boundary of Q in $\mathbb{R}(e_1, \tilde{e}_1) \tilde{+} E^-$.

i) For $(u, \tilde{v}) \in \partial Q \cap E^-$ we have $(u, \tilde{v}) = (u, -\tilde{u})$ and hence

$$J(u, -\tilde{u}) = - \int_{\Omega} \nabla u \nabla \tilde{u} - \int F(u) - \int G(-\tilde{u}) \leq -\|\nabla u\|_{p,q}^2 \leq 0.$$

ii) Let $(u, \tilde{v}) = r(e_1, \tilde{e}_1) \tilde{+} (w, -\tilde{w}) = (re_1 + w, r\widetilde{e_1 - w}) \in \partial Q$, with $\|(w, -\tilde{w})\|_E = R_0, 0 \leq r \leq R_1$.

First set $R_1 = 1$. Then

$$\begin{aligned} J(u, \tilde{v}) &\leq \int_{\Omega} \nabla(re_1 + w) \nabla(r\widetilde{e_1 - w}) \\ &= \int_{\Omega} \nabla(w - re_1) \nabla(w - \widetilde{re_1}) - \int_{\Omega} \nabla(2re_1) \nabla(w - \widetilde{re_1}) \\ &\leq -\|\nabla(w - re_1)\|_{p,q}^2 + 2\|\nabla re_1\|_{p,q} \|\nabla(w - \widetilde{re_1})\|_{p',q'} \\ &\leq -\|\nabla w\|_{p,q}^2 - \|\nabla re_1\|_{p,q}^2 + 2\|\nabla w\|_{p,q} \|\nabla re_1\|_{p,q} \\ &\quad + 2\|\nabla re_1\|_{p,q} (\|\nabla w\|_{p,q} + \|\nabla re_1\|_{p,q}) \\ &\leq -\|\nabla w\|_{p,q}^2 + 4r\|\nabla w\|_{p,q} + r^2 \leq 0 , \end{aligned}$$

for $2\|\nabla w\|_{p,q}^2 = \|\nabla w\|_{p,q}^2 + \|\nabla \tilde{w}\|_{p',q'}^2 = \|(w, -\tilde{w})\|_E^2 = \overline{R}_0^2$ sufficiently large.

Note that this estimate now holds for all $\rho \geq 1$, with $0 \leq r \leq \rho$ and $\|(w, -\tilde{w})\|_E^2 = \rho \overline{R}_0$.

iii) Let $z = \rho(e_1, \tilde{e}_1) \tilde{+} \rho(w, -\tilde{w}) \in \partial Q$, with $\|(w, -\tilde{w})\|_E \leq \overline{R}_0$. Then by A2), for $\theta = \min\{\mu, \nu\} > 2$

$$\begin{aligned} J(u, \tilde{v}) &= \int_{\Omega} \nabla(\rho e_1 + \rho w) \nabla(\rho \widetilde{e_1 - \rho w}) - \int_{\Omega} F(\rho e_1 + \rho w) + G(\rho \widetilde{e_1 - \rho w}) \\ &\leq \rho^2 \|\nabla(e_1 + w)\|_{p,q} \|\nabla(e_1 - w)\|_{p',q'} - c \int_{\Omega} |\rho e_1 + \rho w|^\theta + c_1 \\ &\quad - c \int_{\Omega} |\rho \widetilde{e_1 - \rho w}|^\theta + c_1 \\ &\leq \rho^2 (\|\nabla e_1\|_{p,q} + \|\nabla w\|_{p,q})^2 - c\rho^\theta \left\{ \int_{\Omega} |e_1 + w|^\theta + \int_{\Omega} |\widetilde{e_1 - w}|^\theta \right\} + 2c_1. \end{aligned}$$

It follows that

$$J(u, \tilde{v}) \leq \rho^2(1 + \overline{R}_0)^2 - c\rho^\theta \delta_0 + 2c_1 \leq 0 \tag{11}$$

for $\rho \geq R_1$ sufficiently large, where

$$\delta_0 = \inf_{\|(w, -\tilde{w})\|_E \leq \overline{R}_0} \left\{ \int_{\Omega} |e_1 + w|^\theta + \int_{\Omega} |\widetilde{e_1 - w}|^\theta \right\} > 0 .$$

Finally, defining $R_0 = R_1 \bar{R}_0$, the claim holds.

c) Palais-Smale sequences are bounded

Let $(u_n, \tilde{v}_n) \in E$ with $|J(u_n, \tilde{v}_n)| \leq d$, and

$$|J'(u_n, \tilde{v}_n)[(\phi, \tilde{\psi})]| \leq \varepsilon_n \|(\phi, \tilde{\psi})\|_E, \quad \varepsilon_n \rightarrow 0, \quad \forall (\phi, \tilde{\psi}) \in E. \tag{12}$$

Then $\|(u_n, \tilde{v}_n)\|_E \leq c$.

Indeed, choosing $(\phi, \tilde{\psi}) = (u_n, \tilde{v}_n) = z_n$ in (12) we get, using A2),

$$\begin{aligned} \int_{\Omega} f(u_n)u_n + \int_{\Omega} g(\tilde{v}_n)\tilde{v}_n &\leq 2 \left| \int_{\Omega} \nabla u_n \nabla \tilde{v}_n \right| + \varepsilon_n \|(u_n, \tilde{v}_n)\|_E \\ &\leq 2d + 2 \int_{\Omega} F(u_n) + 2 \int_{\Omega} G(\tilde{v}_n) + \varepsilon_n \|(u_n, \tilde{v}_n)\|_E \\ &\leq 2d + \frac{2}{\mu} \int_{\Omega} f(u_n)u_n + \frac{2}{\nu} \int_{\Omega} g(\tilde{v}_n)\tilde{v}_n + \varepsilon_n \|(u_n, \tilde{v}_n)\|_E \end{aligned}$$

from which we get

$$\int_{\Omega} f(u_n)u_n \leq c + \varepsilon_n \|(u_n, \tilde{v}_n)\|_E, \quad \int_{\Omega} g(\tilde{v}_n)\tilde{v}_n \leq c + \varepsilon_n \|(u_n, \tilde{v}_n)\|_E \tag{13}$$

and then also

$$\int_{\Omega} F(u_n) \leq c, \quad \int_{\Omega} G(\tilde{v}_n) \leq c. \tag{14}$$

Next, taking $(\phi, \tilde{\psi}) = (v_n, 0)$ and $(\phi, \tilde{\psi}) = (0, \tilde{u}_n)$ in (12) we have

$$\|\nabla v_n\|_{p,q}^2 \leq \int_{\Omega} f(u_n)v_n + \varepsilon_n \|(v_n, 0)\|_E, \tag{15}$$

and

$$\|\nabla \tilde{u}_n\|_{p',q'}^2 \leq \int_{\Omega} g(\tilde{v}_n)\tilde{u}_n + \varepsilon_n \|(0, \tilde{u}_n)\|_E. \tag{16}$$

Setting $V_n = \frac{v_n}{\|\nabla v_n\|_{p,q}}$ and $\tilde{U}_n = \frac{\tilde{u}_n}{\|\nabla \tilde{u}_n\|_{p',q'}}$ we obtain

$$\|\nabla v_n\|_{p,q} \leq \int_{\Omega} f(u_n)V_n + \varepsilon_n \quad \text{and} \quad \|\nabla \tilde{u}_n\|_{p',q'} \leq \int_{\Omega} g(\tilde{v}_n)\tilde{U}_n + \varepsilon_n. \tag{17}$$

We now use the following inequalities: for any $\alpha > 1$ (and setting $\alpha' = \frac{\alpha}{\alpha-1}$) holds:

- I) $st \leq t^\alpha + \frac{\alpha-1}{\alpha^{\alpha'}} s^{\alpha'}$ for $s, t \geq 0$
- II) $st \leq \begin{cases} (e^{t^\alpha} - 1) + s(\log^+ s)^{1/\alpha}, & \text{for all } t \geq 0 \text{ and } s \geq e^{(\frac{1}{\alpha})^{\alpha'}} \\ (e^{t^\alpha} - 1) + \frac{\alpha-1}{\alpha^{\alpha'}} s^{\alpha'}, & \text{for all } t \geq 0 \text{ and } 0 \leq s \leq e^{(\frac{1}{\alpha})^{\alpha'}}. \end{cases}$

Proof of I) and II).

I) Consider $\sup_{t \geq 0} \{st - t^\alpha\} = st_s - t_s^\alpha$, with $t_s = (\frac{1}{\alpha} s)^{\frac{1}{\alpha-1}}$, and hence $st_s - t_s^\alpha = (\frac{1}{\alpha})^{\frac{1}{\alpha-1}} s^{\frac{\alpha}{\alpha-1}} - (\frac{1}{\alpha})^{\frac{\alpha}{\alpha-1}} s^{\frac{\alpha}{\alpha-1}} = \frac{\alpha-1}{\alpha^{\alpha'}} s^{\alpha'}$.

II) For fixed $s > 0$, consider $\sup_{t \geq 0} \{st - (e^{t^\alpha} - 1)\}$, and let t_s denote the (unique) point where the supremum is attained; then $s = \alpha t_s^{\alpha-1} e^{t_s^\alpha}$.

i) $t_s \geq (\frac{1}{\alpha})^{\frac{1}{\alpha-1}}$: then $s = \alpha t_s^{\alpha-1} e^{t_s^\alpha} \geq e^{t_s^\alpha}$ and hence $(\log s)^{\frac{1}{\alpha}} \geq t_s$, and then

$$\sup_{t \geq 0} \{st - (e^{t^\alpha} - 1)\} = st_s - (e^{t_s^\alpha} - 1) \leq st_s \leq s(\log s)^{1/\alpha}.$$

ii) $0 \leq t_s \leq (\frac{1}{\alpha})^{\frac{1}{\alpha-1}}$ and $s \geq e^{(\frac{1}{\alpha})^{\alpha'}}$: then $st_s \leq s(\frac{1}{\alpha})^{\frac{1}{\alpha-1}} \leq s(\log^+ s)^{\frac{1}{\alpha}}$, by the assumption on s .

iii) $0 \leq t_s \leq (\frac{1}{\alpha})^{\frac{1}{1-\alpha}}$ and $s \leq e^{(\frac{1}{\alpha})^{\alpha'}}$: in fact, the second inequality in II) holds always, since by I) $st \leq t^\alpha + \frac{\alpha-1}{\alpha^\alpha} s^{\alpha'} \leq (e^{t^\alpha} - 1) + \frac{\alpha-1}{\alpha^\alpha} s^{\alpha'}$, for all $s, t \geq 0$.

We apply the above inequalities I) and II) to the estimates in (17). We distinguish the two cases:

Case (P3): choosing $\alpha = 3, \alpha' = \frac{3}{2}$, inequality I) becomes $st \leq t^3 + cs s^{1/2}$, and then we obtain by the first estimate in (17), setting $t = |V_n(x)|$ and $s = |f(u_n(x))|$, and using A4) and (13)

$$\begin{aligned} \|\nabla v_n\|_{\frac{3}{2},3} &\leq \int_{\Omega} |V_n|^3 + c \int_{\Omega} |f(u_n)| \sqrt{|f(u_n)|} + \varepsilon_n \\ &\leq c \|\nabla V_n\|_{\frac{3}{2},3}^3 + c \int_{\Omega} |f(u_n)| [c_1 + c_2 |u_n|^2]^{1/2} + \varepsilon_n \\ &\leq c + c \int_{\Omega} f(u_n) u_n + \varepsilon_n \\ &\leq c + \varepsilon_n \|(u_n, \tilde{v}_n)\|_E + \varepsilon_n. \end{aligned}$$

Similarly, the second estimate in (17) is estimated by inequality II), with $\alpha = 3$, and $t = |\tilde{U}_n(x)|, s = |g(\tilde{v}_n(x))|$, and, using A5) and (13),

$$\begin{aligned} \|\nabla \tilde{u}_n\|_{3,\frac{3}{2}} &\leq \int_{\Omega} e^{|\tilde{U}_n|^3} + c \int_{\Omega} |g(\tilde{v}_n)| (\log^+ |g(\tilde{v}_n)|)^{1/3} + \varepsilon_n \\ &\leq c + c \int_{\Omega} g(\tilde{v}_n) \tilde{v}_n + \varepsilon_n \\ &\leq c + \varepsilon_n \|(u_n, \tilde{v}_n)\|_E + \varepsilon_n. \end{aligned}$$

Adding the two estimates yields

$$\|\nabla v_n\|_{\frac{3}{2},3} + \|\nabla \tilde{u}_n\|_{3,\frac{3}{2}} \leq c + 2\varepsilon \|(u_n, \tilde{v}_n)\|_E + 2\varepsilon_n$$

and hence $\|(u_n, \tilde{v}_n)\|_E \leq c$.

Case (P2): we proceed similarly, applying inequality II) with $\alpha = q'$ and $t = |V_n(x)|, s = |f(u_n(x))|$, to the first estimate in (16):

$$\begin{aligned}
 \|\nabla v_n\|_{2,q} &\leq \int_{\Omega} f(u_n)V_n + \varepsilon_n \\
 &\leq \int_{\Omega} (e^{|V_n|^{q'}} - 1) + \int_{\Omega} |f(u_n)| [\log^+ |f(u_n)|]^{1/q'} + \varepsilon_n \\
 &\leq c + \int_{\Omega} f(u_n)u_n + \varepsilon_n \\
 &\leq c + \varepsilon_n + \varepsilon_n \|(u_n, \tilde{v}_n)\|_E.
 \end{aligned}$$

Applying inequality II) with $\alpha = q$ and $t = |\tilde{U}_n|$, $s = |g(v_n)|$, to the second estimate in (17), and using A5) and (13) yields

$$\begin{aligned}
 \|\nabla \tilde{u}_n\|_{2,q'} &\leq \int_{\Omega} g(\tilde{v}_n)\tilde{U}_N + \varepsilon_n \\
 &\leq \int_{\Omega} (e^{\tilde{U}_n^q} - 1) + \int_{\Omega} |g(\tilde{v}_n)| [\log^+ |g(\tilde{v}_n)|]^{1/q} + \varepsilon_n \tag{18} \\
 &\leq c + \int_{\Omega} g(\tilde{v}_n)\tilde{v}_n + \varepsilon_n \\
 &\leq c + \varepsilon_n \|(u_n, \tilde{v}_n)\|_E + \varepsilon_n.
 \end{aligned}$$

Joining the two inequalities yields again the boundedness of $\|(u_n, \tilde{v}_n)\|_E$.

d) Finite-dimensional approximation

Note that the functional J is strongly indefinite on the space E (i.e. positive and negative definite on infinite dimensional manifolds), and hence the standard linking theorems cannot be applied. We therefore consider an approximate problem on finite dimensional spaces (Galerkin approximation):

Denote by $(e_i)_{i \in \mathbb{N}}$ an orthonormal set of eigenfunctions corresponding to the eigenvalues $(\lambda_i)_{i \in \mathbb{N}}$, $i \in \mathbb{N}$, of $(-\Delta, H_0^1(\Omega))$, and set

$$\begin{aligned}
 E_n^+ &= \text{span}\{(e_i, \tilde{e}_i) \mid i = 1, \dots, n\} \\
 E_n^- &= \text{span}\{(e_i, -\tilde{e}_i) \mid i = 1, \dots, n\} \\
 E_n &= E_n^- \tilde{\oplus} E_n^-.
 \end{aligned}$$

Set now $Q_n = Q \cap E_n$, Q as in b) above, and define the family of mappings

$$\Gamma_n = \{\gamma \in C(Q_n, E_n^- \tilde{\oplus} [(e_1, \tilde{e}_1)]) \mid \gamma(z) = z \text{ on } \partial Q_n\}$$

and set

$$c_n = \inf_{\gamma \in \Gamma_n} \max_{z \in Q_n} J(\gamma(z)) .$$

It is now quite standard (see [15], [7]) to conclude that:

For each $n \in \mathbb{N}$ the functional $J_n = J|_{E_n}$ has a critical point $z_n = (u_n, \tilde{v}_n) \in E_n$ at level c_n , with

$$J(z_n) = c_n \in [\sigma, R_1] \tag{19}$$

and

$$J'(z_n)[(\phi, \tilde{\psi})] = 0 , \text{ for all } (\phi, \tilde{\psi}) \in E_n \tag{20}$$

and hence

$$\begin{cases} \int_{\Omega} \nabla u_n \nabla \tilde{\psi} = \int_{\Omega} g(\tilde{v}_n) \tilde{\psi} \\ \int_{\Omega} \nabla \tilde{v}_n \nabla \phi = \int_{\Omega} f(u_n) \phi \end{cases}, \quad \forall (\phi, \tilde{\psi}) \in E_n. \tag{21}$$

e) Limit $n \rightarrow \infty$

By d) we find a sequence $(u_n, \tilde{v}_n) \in E_n$ with

$$J(u_n, \tilde{v}_n) \rightarrow c \in [\sigma, R_1] \quad \text{and} \quad J'_n(u_n, \tilde{v}_n) = 0, \quad \text{in } E_n,$$

and by c) we have $\|(u_n, \tilde{v}_n)\|_E \leq c$. Then $(u_n, \tilde{v}_n) \rightharpoonup (u, \tilde{v})$ in E . Furthermore, we may assume that

$$\tilde{v}_n \rightarrow \tilde{v} \quad \text{in } L^\alpha, \quad \text{for all } \alpha \geq 1;$$

indeed, in the case (P3) we have by properties 1), 2) of Lorentz spaces, for all $\delta > 0$, the following continuous embeddings

$$W_0^1 L(3, \frac{3}{2}) \subset W_0^1 L(3 - \delta, 3 - \delta) = W_0^{1, 3-\delta} \subset L^{\frac{(3-\delta)N}{N-(3-\delta)}} = L^{\frac{(3-\delta)3}{\delta}}$$

and hence a compact embedding into L^α , for all $1 \leq \alpha < \frac{(3-\delta)3}{\delta}$.

Similarly, we have in the case (P2):

$$W_0^1 L(2, q) \subset W_0^1 L(2 - \delta, 2 - \delta) = W_0^{1, 2-\delta} \subset L^{\frac{(2-\delta)2}{\delta}},$$

and hence again a compact embedding into L^α , for all $1 \leq \alpha < \frac{(2-\delta)2}{\delta}$.

Using (13) and (14) one concludes now as in [9], Lemma 2.1, that

$$\int_{\Omega} f(u_n) \rightarrow \int_{\Omega} f(u), \quad \int_{\Omega} g(\tilde{v}_n) \rightarrow \int_{\Omega} g(\tilde{v}).$$

Thus, in (21) we can take the limit $n \rightarrow \infty$ to obtain

$$\begin{cases} \int_{\Omega} \nabla u \nabla \tilde{\psi} = \int_{\Omega} g(\tilde{v}) \tilde{\psi} \\ \int_{\Omega} \nabla \tilde{v} \nabla \phi = \int_{\Omega} f(u) \phi \end{cases}, \quad \forall (\phi, \tilde{\psi}) \in \cup E_n = E. \tag{22}$$

Hence $(u, \tilde{v}) \in E$ is a (weak) solution of (22).

Finally, we prove that $(u, \tilde{v}) \in E$ is nontrivial. Assume by contradiction that $u = 0$, which implies that also $v = 0$. Since g is subcritical, we obtain by A5), for all $\delta > 0$,

$$|g(t)| \leq c_\delta e^{\delta|t|^3}, \quad \forall t \in \mathbb{R}, \quad \text{in case (P3)}$$

$$|g(t)| \leq c_\delta e^{\delta|t|^q}, \quad \forall t \in \mathbb{R}, \quad \text{in case (P2)}.$$

Now we choose $\tilde{\psi} = \tilde{v}_n$ in the first equation of (22), and estimate by Hölder

$$\begin{aligned} \left| \int_{\Omega} g(\tilde{v}_n)\tilde{v}_n \right| &\leq c_{\delta} \|e^{\delta|\tilde{v}_n|^3}\|_{L^{\beta}} \|\tilde{v}_n\|_{L^{\alpha}} \leq d_{\delta} \|\tilde{v}_n\|_{L^{\alpha}} \text{ , in case (P3) ,} \\ \left| \int_{\Omega} g(\tilde{v}_n)\tilde{v}_n \right| &\leq c_{\delta} \|e^{\delta|\tilde{v}_n|^q}\|_{L^{\beta}} \|\tilde{v}_n\|_{L^{\alpha}} \leq d_{\delta} \|\tilde{v}_n\|_{L^{\alpha}} \text{ , in case (P2) ,} \end{aligned}$$

since $\|\nabla\tilde{v}_n\|_{3, \frac{3}{2}} \leq c$ and $\|\nabla\tilde{v}_n\|_{2, q} \leq c$, respectively, and hence by Theorem C above, for $\beta > 1$ sufficiently small:

$$\|e^{\delta|\tilde{v}_n|^3}\|_{L^{\beta}} = \int_{\Omega} e^{\delta\beta|\tilde{v}_n|^3} \leq c \text{ , and } \|e^{\delta|\tilde{v}_n|^q}\|_{L^{\beta}} = \int_{\Omega} e^{\delta\beta|\tilde{v}_n|^q} \leq c \text{ .}$$

Since $\|\tilde{v}_n\|_{L^{\alpha}} \rightarrow 0$, we conclude by the first equation in (21) that

$$\int_{\Omega} \nabla u_n \nabla \tilde{v}_n \rightarrow 0 \text{ .} \tag{23}$$

This in turn implies, by choosing $\phi = u_n$ in the second equation in (21), that also $\int_{\Omega} f(u_n)u_n \rightarrow 0$. By assumption A2) we now conclude that

$$\int_{\Omega} F(u_n) \rightarrow 0 \text{ , and } \int_{\Omega} G(u_n) \rightarrow 0 \text{ .} \tag{24}$$

Finally, by (23) and (24) we now obtain that $J(u_n, \tilde{v}_n) = \int_{\Omega} \nabla u_n \nabla \tilde{v}_n - \int_{\Omega} F(u_n) + G(\tilde{v}_n) \rightarrow 0$; but this contradicts (19), and thus $(u, \tilde{v}) \neq (0, 0)$.

This completes the proof. □

References

- [1] R. A. Adams, *Sobolev Spaces*, Academic Press, 1975.
- [2] Adimurthi and S.L. Yadava, *Multiplicity results for semilinear elliptic equations in a bounded domain of \mathbb{R}^2 involving critical exponent*, Ann. Sc. Norm. Sup. Pisa **XVII** (1990), 481–504.
- [3] H. Brezis, *Laser beams and limiting cases of Sobolev inequalities*, Nonlinear Partial Differential Equations and their Applications, Collège de France Seminar, Vol. II, H. Brezis, J.L. Lions, eds., Pitman, 1982.
- [4] H. Brezis and S. Wainger, *A note on limiting cases of Sobolev embeddings and convolution inequalities*, Comm. P.D.E. **5** (1980), 773–789.
- [5] D. G. de Figueiredo and P. Felmer, *On superquadratic elliptic systems*, Trans. Amer. Math. Soc. **343** (1994), 99–116.
- [6] D. G. de Figueiredo, J. M. do Ó and B. Ruf, *Critical and subcritical elliptic systems in dimension two*, Indiana University Mathematics Journal, **53** (2004), 1037–1053.
- [7] D. G. de Figueiredo, J. M. do Ó and B. Ruf, *An Orlicz space approach to superlinear elliptic systems*, J. Functional Analysis, to appear.
- [8] D. G. de Figueiredo and B. Ruf, *Elliptic systems with nonlinearities of arbitrary growth*, Mediterr. J. Math. **1** (2004) 417–431.

- [9] D. G. de Figueiredo, O. H. Miyagaki and B. Ruf, *Elliptic equations in \mathbb{R}^2 with nonlinearities in the critical growth range*, Calc. Var. **3** (1995), 139–153.
- [10] J. Hulshof, E. Mitidieri and R. van der Vorst, *Strongly indefinite systems with critical Sobolev exponents*, Trans. Amer. Math. Soc. **350** (1998), 2349–2365.
- [11] J. Hulshof and R. van der Vorst, *Differential systems with strongly indefinite variational structure*, J. Funct. Anal. **114** (1993), 32–58.
- [12] E. Mitidieri, *A Rellich type identity and applications*, Comm. Partial Diff. Equations **18** (1993), 125–151.
- [13] J. Moser, *A sharp form of an inequality by N. Trudinger*, Ind. Univ. J. **20** (1971), 1077–1092.
- [14] S. I. Pohozaev, *The Sobolev embedding in the case $pl = n$* , Proceedings of the Technical Scientific Conference on Advances of Scientific Research 1964–1965. Mathematics Section, 158–170, Moscov. Ènerget. Inst., Moscow, 1965.
- [15] P. H. Rabinowitz, *Minimax Methods in Critical Point Theory with Applications to Differential Equations*, CBMS Regional Conf. Ser. in Math. **65**, AMS, Providence, RI, 1986.
- [16] R. S. Strichartz, *A note on Trudinger's extension of Sobolev's inequality*, Indiana U. Math. J. **21** (1972), 841–842.
- [17] N. S. Trudinger, *On imbeddings into Orlicz spaces and some applications*, J. Math. Mech. **17** (1967), 473–484.
- [18] R. van der Vorst, *Variational identities and applications to differential systems*, Arch. Rat. Mech. Anal. **116** (1991), 375–398.

Bernhard Ruf
Dipartimento di Matematica
Università degli Studi
Via Saldini 50
20133 Milano
Italy
e-mail: ruf@mat.unimi.it

The Topology of Critical Sets of Some Ordinary Differential Operators

Nicolau C. Saldanha and Carlos Tomei

Dedicated to Djairo Figueiredo, with affection and admiration.

Abstract. We survey recent work of Burghelea, Malta and both authors on the topology of critical sets of nonlinear ordinary differential operators. For a generic nonlinearity f , the critical set of the first order nonlinear operator $F_1(u)(t) = u'(t) + f(u(t))$ acting on the Sobolev space H_p^1 of periodic functions is either empty or ambient diffeomorphic to a hyperplane. For the second order operator $F_2(u)(t) = -u''(t) + f(u(t))$ on H_D^2 (Dirichlet boundary conditions), the critical set is ambient diffeomorphic to a union of isolated parallel hyperplanes. For second order operators on H_p^2 , the critical set is not a Hilbert manifold but is still contractible and admits a normal form. The third order case is topologically far more complicated.

Mathematics Subject Classification (2000). Primary 34L30, 58B05; Secondary 34B15, 46T05.

Keywords. Sturm-Liouville, nonlinear differential operators, infinite dimensional manifolds.

1. Introduction

We survey recent work of Burghelea, Malta and both authors on the topology of critical sets C of (nonlinear, ordinary) differential operators F . Our approach is *geometric*, in the sense that we study the geometry and topology of C and its image $F(C)$ with the purpose of understanding the function F . Pioneering examples of this point of view for nonlinear differential equations are the results on the Laplacian coupled to a special nonlinearity by Ambrosetti and Prodi ([1]), interpreted as properties of a global fold by Berger and Podolak ([2]).

We begin this paper with a two dimensional example in which most of our claims can be followed visually. We then consider differential operators of increasing difficulty. For generic nonlinearities $f : \mathbb{R} \rightarrow \mathbb{R}$, set $F_1(u) = u' + f(u)$ on the

Sobolev space H_p^1 of periodic functions ([14]), with critical set C_1 . We show that if C_1 is not empty then there is a global diffeomorphism in the domain of F_1 converting C_1 into a hyperplane. There are two parts in the argument. First, we prove that the homotopy groups of C_1 are trivial. We then use the fact that, under very general conditions, (weak) homotopically equivalent infinite dimensional Hilbert manifolds are actually diffeomorphic. For some classes of nonlinearities, we achieve a global normal form for F_1 .

We proceed to the second order operator $F_{2,D}(u) = -u'' + f(u)$ acting on $H_D^2([0, \pi])$, the Sobolev space of functions satisfying Dirichlet boundary conditions ([4]). The critical set $C_{2,D}$ now splits into connected components $C_{2,D,m}$, one for each positive integer value of m for which $-m^2$ is in the interior of the image of f' . Again, there exists a diffeomorphism taking each $C_{2,D,m}$ to a hyperplane. The proof of the triviality of homotopy groups of $C_{2,D,m}$ requires a very different strategy than the first order case.

Second order operators on H_p^2 (the space of periodic functions) are more complicated, in the sense that the critical set is not a manifold, but with suitable hypothesis is still contractible and admits a normal form ([5], [6]). In brief, the critical set looks like a union of a hyperplane and infinitely many cones, with nonregular points at the vertices. Nonregular points in the critical set correspond to potentials $h(t) = f'(u(t))$, $u \in H_p^2$, for which the kernel of the linear operator $v \mapsto -v'' + h(t)v$ is a subspace of dimension 2 of H_p^2 . The diffeomorphism of H_p^2 through which the critical set achieves its normal form takes the set of nonregular critical points to a disjoint union of linear subspaces of codimension 3.

The third order case is yet more complicated: consider the set $C_{3,p}^*$ of pairs (h_0, h_1) for which the kernel of the linear operator $u \mapsto u''' + h_1u' + h_0u$ is a subspace of H_p^3 of dimension 3. In the final section we show that the space C_3^* is homotopically equivalent to X_I , the set of closed locally convex curves in the sphere S^2 with a prescribed initial base point and direction. It turns out that the space X_I has three connected components ([11]), two of them having a rich algebraic topological structure, not equivalent to any finitely generated CW-complex ([18], [20], [21], [22]).

The authors acknowledge the support of CNPq, Faperj and Finep.

2. A finite dimensional example

Consider

$$F : \mathbb{C} \rightarrow \mathbb{C}$$

$$z \mapsto z^7 + 5\bar{z}^4 + z$$

which is clearly a smooth (but not analytic) function from the plane \mathbb{R}^2 to itself. In this section, we identify \mathbb{C} and \mathbb{R}^2 indiscriminately. How many solutions has the equation $F(z) = 0$?

Our approach to the question ([13], [19]) breaks into a few steps. First, we compute the critical set C of F by searching for points in the plane in which the Jacobian DF is not invertible. Some numerical analysis reveals that C consists of two simple curves C_i and C_o bounding disks $(0, 0) \in D_i \subset D_o$. A finer inspection verifies that, as expected from Whitney's classical theorems on planar singularity theory ([23]), the generic critical point is a *fold*, i.e., after local changes of variables the function takes the form $(x, y) \mapsto (x, y^2)$ close to the origin. Also, nonfold points are *cusps*, with local normal form $(x, y) \mapsto (x, y^3 + xy)$. Again, with the help of some computation, one finds out that the curves C_i and C_o have five and eleven cusps, respectively. What may be more informative is the geometry of the images $F(C_i)$ and $F(C_o)$, presented in the picture below.

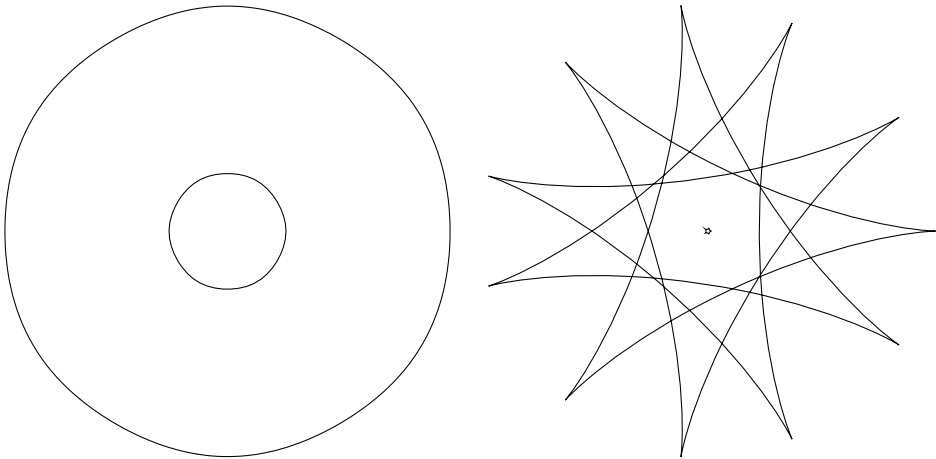

FIGURE 1. The critical set of the function $F(z) = z^7 + 5z^4 + z$ and its image.

We now count preimages. Simple estimates suffice to prove that F is proper, and that, for sufficiently large $(w_1, w_2) \in \mathbb{R}^2$, the equation $F(x, y) = (w_1, w_2)$ has seven solutions. From properness, points in the same connected component of the complement of $F(C)$ have the same number of pre-images. Now, consider two points p and q in components sharing a boundary arc of (images of) folds. From the normal form of a function at a fold point, the number of preimages of p and q under F differ by two. The *sense of folding* indicates that the number of preimages *increases* by two whenever one gets closer to the origin when trespassing an arc of images of folds. Adding up, from the knowledge that points in the unbounded connected component of the complement of $F(C)$ have seven preimages, we learn the number of preimages of each component. Thus, the origin has 17 preimages. In a nutshell, the number of preimages of a point under a function F may become large when the image of the critical set C intersects itself abundantly.

In the following sections, we shall consider functions between separable infinite dimensional Hilbert spaces. In many cases, the critical set turns out to be surprisingly simple.

3. The first order operator

We consider the differential equation

$$u'(t) + f(u(t)) = g(t), \quad u(0) = u(\pi)$$

where the unknown u is a real function and $f : \mathbb{R} \rightarrow \mathbb{R}$ is a smooth nonlinearity. In the spirit of the example in the previous section, we define the operator

$$F_1 : H_p^1 \rightarrow L^2$$

$$u \mapsto u' + f(u)$$

where $H_p^1 = H_p^1([0, 1]; \mathbb{R}) = H^1(\mathbb{S}^1; \mathbb{R})$ is the Sobolev space of periodic functions with weak derivative in $L^2 = L^2([0, 1]; \mathbb{R})$. It is easy to verify that the differential

$$DF_1(u)v = v' + f'(u)v$$

is a Fredholm operator of index 0 and therefore u belongs to the critical set $C_1 \subset H_p^1$ of F_1 if and only if the equation

$$v'(t) + f'(u(t))v(t) = 0, \quad v(0) = v(1)$$

admits a nontrivial solution v , i.e.,

$$C_1 = \{u \in H_p^1 \mid \phi_1(u) = 0\}, \quad \phi_1(u) = \int_0^1 f'(u(t))dt.$$

An equivalent spectral interpretation for C_1 is

$$C_1 = \{u \in H_p^1 \mid 0 \in \sigma(DF_1(u))\}.$$

It is not hard to see ([14]) that $DF_1(u)$ has a unique real eigenvalue. We assume that f'' has isolated roots which are distinct from the roots of f' : this implies that 0 is a regular value of ϕ_1 and therefore that C_1 is a smooth hypersurface in H_p^1 . An \mathbb{H} -manifold is a manifold modeled on the separable infinite dimensional Hilbert space \mathbb{H} : C_1 is an \mathbb{H} -manifold. With these hypothesis, the topology of C_1 is trivial ([14]):

Theorem 1. *Assume C_1 to be nonempty. Then C_1 is path connected and contractible. Furthermore, there is a diffeomorphism from H_p^1 to itself taking C_1 to a hyperplane.*

A natural finite dimensional counterpart of this theorem is false. Indeed, let

$$C_1^n = \{u \in \mathbb{R}^n \mid \phi_1^n(u) = 0\}, \quad \phi_1^n(u) = \sum_k f'(u_k).$$

For $f(x) = x^3 - x$, C_1^n is a sphere. Thus, our theorem goes hand in hand with the well known facts that in an infinite dimensional Hilbert space \mathbb{H} , the unit sphere

is contractible and there is a diffeomorphism of \mathbb{H} to itself taking the unit sphere to a hyperplane.

The rest of this section outlines the proof of theorem 1. First, one proves ([15]) that the homotopy groups $\pi_k(C_1)$ are trivial. We consider only $k = 0$, i.e., path connectedness of C_1 , the other cases being similar. This is done first in the space C^0 (with the sup norm): more precisely, set

$$C_1^0 = \{u \in C^0([0, 1]) \mid \phi_1(u) = 0\};$$

it is easier to build a homotopy in the sup norm, since it is weaker. Take two functions $u_0(t)$ and $u_1(t)$ in C_1^0 so that

$$\int_0^1 f(u_0(t))dt = \int_0^1 f(u_1(t))dt = 0.$$

Let $s \in [0, 1]$ be the parameter for the desired homotopy $\mathbf{h}(s, t)$: we want $\mathbf{h}(0, t) = u_0(t)$, $\mathbf{h}(1, t) = u_1(t)$, $\mathbf{h}(s, \cdot) \in C_1^0$. Define a discontinuous function $\mathbf{h}_0 : [0, 1] \times [0, 1] \rightarrow \mathbb{R}$ by $\mathbf{h}_0(s, t) = u_0(t)$ if $(s, t) \in A \subset [0, 1] \times [0, 1]$ and $\mathbf{h}_0(s, t) = u_1(t)$ otherwise, where A looks like the set in figure 2: for each s , $A_s = \{t \mid (s, t) \in A\}$ is a rather uniformly distributed subset of $[0, 1]$ of measure $1 - s$. For each s , $\phi_1(\mathbf{h}_0(s, \cdot)) \approx 0$. The function H equals \mathbf{h}_0 except on a set of very small measure, where it is defined so as to obtain a continuous \mathbf{h} for which $\phi_1(\mathbf{h}(s, \cdot)) = 0$.

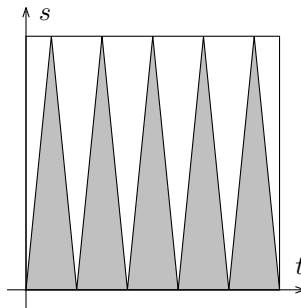

FIGURE 2. The set A (shaded).

In order to prove that the homotopy groups $\pi_k(C_1)$ are also trivial, we use the following theorem ([4]) with $Y = H_p^1$, $X = C^0([0, 1])$, $M = C_1^0$, $N = C_1$ and i the inclusion.

Theorem 2. *Let X and Y be separable Banach spaces. Suppose $i : Y \rightarrow X$ is a bounded, injective map with dense image and $M \subset X$ a smooth, closed submanifold of finite codimension. Then $N = i^{-1}(M)$ is a smooth closed submanifold of Y , and the restrictions $i : Y - N \rightarrow X - M$ and $i : (Y, N) \rightarrow (X, M)$ are homotopy equivalences.*

Since C_1 , being an \mathbb{H} -manifold, is homotopy equivalent to a CW-complex, weak contractibility implies contractibility and C_1 is contractible (and, by theorem 2, C_1^0 is contractible too). The connected components of the complement of C_1 are also contractible. Indeed, let $h : \mathbb{S}^k \rightarrow H_p^1 - C_1$ be a continuous map; since H_p^1 is obviously contractible, h can be extended to $\mathbf{h} : \mathbb{B}^{k+1} \rightarrow H_p^1$. Since C_1 is contractible, \mathbf{h} can be redefined to take each connected component of $\mathbf{h}^{-1}(H_p^1 - C_1)$ not touching \mathbb{S}^k to C_1 . A normal vector to C_1 can then be used to push the image of \mathbf{h} away from C_1 , yielding $\mathbf{h} : \mathbb{B}^{k+1} \rightarrow H_p^1 - C_1$. Thus, the homotopy groups $\pi_k(H_p^1 - C_1)$, $k \geq 1$, are trivial and therefore the connected components of $H_p^1 - C_1$ are contractible. To complete the proof of theorem 1, we use the following result ([4]):

Theorem 3. *Suppose $f : (V_1, \partial V_1) \rightarrow (V_2, \partial V_2)$ is a smooth homotopy equivalence of \mathbb{H} -manifolds with boundary, $K_2 \subset V_2 \setminus \partial V_2$ a closed submanifold of finite codimension and $K_1 = f^{-1}(K_2)$. Suppose also that f is transversal to K_2 and the maps $f : K_1 \rightarrow K_2$ and $f : V_1 - K_1 \rightarrow V_2 - K_2$ are homotopy equivalences. Then there exists a diffeomorphism between $(V_1; \partial V_1, K_1)$ and $(V_2; \partial V_2, K_2)$ which is homotopic to f as maps of triples.*

Set $V_1 = H_p^1$ and consider the functional $\phi_1 : H_p^1 \rightarrow \mathbb{R}$ defined above. Write $V_2 = L^2([0, 1]) = \langle 1 \rangle \oplus \langle 1 \rangle^\perp$, where $\langle 1 \rangle \cong \mathbb{R}$ is the vector space of constant functions and $\langle 1 \rangle^\perp$, the space of functions v of average \bar{v} equal to zero, is a hyperplane in V_2 . Set $f : V_1 \rightarrow V_2$ to be $f(u) = (\phi_1(u), 0)$. Set $K_2 = \langle 1 \rangle^\perp$ so that the critical set C_1 equals $K_1 = f^{-1}(K_2)$, and the genericity condition on f ensures that $C_1 = K_1$ is a hypersurface of V_1 and f is transversal to K_2 . Notice that $\partial V_1 = \partial V_2 = \emptyset$. Since $K_1 = C_1$ is contractible, we obtain that f is a homotopy equivalence between K_1 and K_2 . Similarly, since the connected components of $V_1 - K_1$ are contractible, $f : V_1 - K_1 \rightarrow V_2 - K_2$ is a homotopy equivalence and Theorem 1 follows.

The proofs of theorems 2 and 3 are rather technical and shall not be discussed here. A simple spinoff is the following density result which may be of independent interest.

Theorem 4. *Let X be a Banach space, $V \subset X$ a dense (linear) subspace and $M \subset X$ a finite codimension submanifold. Then the intersection $V \cap M$ is dense in M .*

4. More on C_1 and $F_1(C_1)$

For the first order differential operator F_1 , generically, it is easy to prove that the critical C_1 stratifies by complexity of the singularities, which are infinite dimensional counterparts of the familiar Morin singularities ([16], [14]). In a nutshell, the Morin singularity is the generic situation for a germ from $(\mathbb{R}^n, 0)$ to itself whose Jacobian at 0 has a one dimensional kernel. There is essentially one *elementary* Morin singularity in each dimension, with very simple normal forms: the fold $x \mapsto x^2$, the cusp $(x, y) \mapsto (x, y^3 + xy)$, the swallowtail $(x, y, z) \mapsto (x, y, z^4 + yz^2 + xz)$, the

butterfly $(x, y, z, t) \mapsto (x, y, z, t^5 + zt^3 + yt^2 + xt), \dots$ One should take into account Morin singularities arising by taking cartesian products: the fold $x \mapsto x^2$ embeds into the (non-elementary) fold $(x, y) \mapsto (x^2, y)$. Even in infinite dimensions, Morin singularities are always cartesian products of an elementary singularity (for which one defines a natural *order*, given by the degree of the top polynomial of its normal form) and the identity mapping with the appropriate codimension ([14]; also [9] for infinite dimensional cusps).

What is the topology of the finer strata? For the first order differential operator F_1 with a generic nonlinearity f , the subset Σ_2 of critical points which are nonfold points again has trivial topology. The proof of this statement begins with the following result:

Theorem 5. *For a generic smooth nonlinearity $f : \mathbb{R} \rightarrow \mathbb{R}$, there is a diffeomorphism from H_p^1 to itself taking the sets C_1 and Σ_2 of F_1 respectively to the zero level of the functional ϕ_1 and to the zero level of the pair $(\phi_1, \phi_{1,2})$, where*

$$\phi_{1,2}(u) = \int_0^1 f''(u(t))dt.$$

Consider now a vector valued extension of the argument used to prove that the homotopy groups of C_1 are trivial ([15]). Let M be a compact, finite dimensional manifold with a smooth Riemannian metric inducing a normalized measure μ , so that $\mu(M) = 1$. Let V a separable Banach space of continuous real valued functions on M , which is closed under multiplication by functions of $C^\infty(M)$ (here, multiplication in $C^\infty(M) \times V \rightarrow V$ is continuous). For a smooth function $f_n : M \times \mathbb{R} \rightarrow \mathbb{R}^n$ define $N_n : V \rightarrow \mathbb{R}^n$ as the average of the Nemytskiï operator associated to f ,

$$N_n(v) = \int_M f_n(m, v(m))d\mu.$$

Let $\Pi_k : \mathbb{R}^n \rightarrow \mathbb{R}^k$ be the projection on the first k coordinates. We say that 0 is a *strong regular value* of N_n if 0 is a regular value of each composition $N_k = \Pi_k \circ F_n$. Finally, let $Z_k = N_k^{-1}(0)$: if 0 is a strong regular value of N_n , the sets Z_k are nested submanifolds of V of codimension k .

Theorem 6. *Suppose 0 is a strong regular value of N_n as above. Then the levels Z_k are contractible. Moreover, there is a global homeomorphism $\Psi : V \rightarrow V$ taking each Z_k to a closed linear subspace of V of codimension k . If V is a Hilbert space, ψ can be taken to be a diffeomorphism.*

Thus, for a generic nonlinearity, the zero levels of ϕ_1 and $(\phi_1, \phi_{1,2})$ are ambient diffeomorphic to nested subspaces of codimension 1 and 2, and we obtain the topological triviality of C_1 (again) and of Σ_2 . Theorem 5 is necessary because the set of nonfold points is *not* described naturally in terms of zero levels of vector Nemytskiï operators. This is the reason for which we do not know how to address topological properties of higher order strata.

The image $F(C_1)$ clearly depends on the nonlinearity. We list a few facts ([14]), some of which had been known ([12]).

1. Suppose f is strictly increasing, onto the interval (a, b) . Then F_1 is a diffeomorphism onto the strip

$$\{w \in L^2 \mid a < \langle w, 1 \rangle < b\}.$$

2. If f is strictly convex, F_1 is a global fold. If f is generic, and all critical points of F_1 are folds, then F_1 is a global fold. There are nonconvex linearities for which F_1 is a global fold.
3. If f is a generic polynomial of even degree, positive leading coefficient, taking negative values, then F_1 has cusps.
4. Suppose $f : \mathbb{R} \rightarrow \mathbb{R}$ is proper, with derivative f' assuming both signs and third derivative with isolated roots assuming only one sign. Then F_1 is a global cusp, in the sense that diffeomorphisms on H_p^1 and L^2 convert F_1 to the normal form

$$\begin{aligned} \tilde{F}_1 : \mathbb{R}^2 \times \mathbb{H} &\rightarrow \mathbb{R}^2 \times \mathbb{H} \\ (x, y; v) &\mapsto (x, y^3 + xy; v). \end{aligned}$$

The last example establishes a conjecture by Cafagna and Donati ([7]) on the global topology of operators associated to the nonlinearity $f(x) = ax + bx^2 + cx^{2k+1}$, $a \geq 0$, $a^2 + b^2 > 0$ and $c < 0$.

From the examples, the number of preimages of an operator associated to a generic nonlinearity given by a polynomial of degree less than or equal to three is bounded by the degree of the polynomial. This is false for polynomials of degree four. The counterexample in [14] was obtained by adjusting coefficients of the nonlinearity in order to obtain a butterfly in the critical set of F_1 . Singularity theory combined with a degree theoretic argument imply the existence of a point with six preimages, five of which are near the butterfly. Both nonlinearity and special point were computed numerically.

On a related note, Pugh conjectured that the equation

$$u'(t) = a_k(t)(u(t))^k + \dots + a_1(t)u(t) + a_0(t), \quad u(1) = u(0)$$

would have at most k solutions. The conjecture was essentially verified by Smale for $k = 2$ and $k = 3$ if $a_3(t) > 0$ for all t . The general conjecture was proved false by Lins Neto ([10]) but is correct in certain special cases ([8]). Our example has the special feature that a_i is constant in t for $i > 0$.

5. The second order case, Dirichlet conditions

Let $H_D^2 = H_D^2([0, \pi], \mathbb{R})$ be the Sobolev space of functions with second weak derivative in $L^2 = L^2([0, \pi]; \mathbb{R})$, satisfying Dirichlet boundary conditions and for a smooth nonlinearity f now consider the operator

$$\begin{aligned} F_{2,D} : H_D^2 &\rightarrow L^2 \\ u &\mapsto -u'' + f(u) \end{aligned}$$

with differential given by $DF_{2,D}(u)v = -v'' + f'(u)v$. Again, by Fredholm theory, the critical set $C_{2,D}$ of $F_{2,D}$ consists of functions $u \in H_D^2$ for which $DF_{2,D}$ has zero in the spectrum.

For a more explicit description of $C_{2,D}$, define the fundamental solution v_1 ,

$$-v_1'' + f'(u)v_1 = 0, \quad v_1(0) = 0, v_1'(0) = 1,$$

and consider the (continuously defined) argument $\omega(t)$ of the vector $(v_1'(t), v(t))$ for which $\omega(0) = 0$. Notice the implicit dependence of ω on v_1 , which in turn depends on u . Then

$$C_{2,D} = \{u \in H_D^2 \mid \omega(\pi)/\pi \in \mathbb{Z}\}.$$

Thus, there must be different connected components of $C_{2,D}$ for each value of $\omega(\pi) = m\pi$. Said differently, the fact that the eigenvalue 0 of $DF_{2,D}(u)$ may be the m -th eigenvalue in the spectrum (counting from below) induces different critical components of $F_{2,D}$. Define the functional $\phi_{2,D}(u)$ as the value of the argument at π of the fundamental solution v_1 associated to u and consider subsets $C_{2,D,m}$ which partition $C_{2,D}$, given by the $m\pi$ -levels of $\phi_{2,D}$. For a generic set of nonlinearities f , the set $C_{2,D,m}$ is nonempty if and only if the number $-m^2$ belongs to the interior of the image of f' : in this case, $C_{2,D,m}$ is path connected and contractible.

We want to prove that arbitrary functions from a sphere \mathbb{S}^k to $C_{2,D,m}$ are homotopic to constants. Theorem 6 is not the appropriate tool anymore, among other reasons because the functional $\phi_{2,D}$ depends on the derivative u' . From the topological theorems of section 3, it suffices to control the deformation in the sup norm. Contractibility then implies a global change of variables in H_D^2 which flattens the connected components $C_{2,D,m}$ into hyperplanes. The stratification of the critical set in Morin singularities still applies, but there are no results at this point about the global topology of the finer strata.

The idea behind the construction of the homotopy is to change u so as to approach a function u_* which is constant equal to a value x_m with the property that $f'(x_m) = -m^2$ except for two small intervals at the endpoints. Notice that the (fundamental) solution of

$$-v'' - m^2v = 0, \quad v(0) = 0, v'(0) = 1$$

is the function $v(t) = \sin(mt)/m$. In general, define the m -argument $\omega_m(t)$, the argument of the vector $(v_1'(t), mv_1(t))$. Since $\omega(t) = \omega_m(t)$ if $\omega(t) = k\pi, k \in \mathbb{Z}$, the sets $C_{2,D,m}$ are $m\pi$ -levels for both $\omega(\pi)$ and $\omega_m(\pi)$. Better still, the m -argument of $v(t) = \sin(mt)/m$ varies linearly from 0 to $m\pi$ for $t \in [0, \pi]$. In figure 3 we show an example of $u \in C_{2,D,m}, m = 2$, and in dotted lines the constant value x_m ; below we show the m -argument ω_m of u and the constant function x_m .

The homotopy squeezes the graph of ω_m between parallel walls advancing towards the line $y = mt$, as shown in figure 4. A corresponding u is obtained by changing its original value in the region of the domain over which the graph of ω_m has been squeezed—there, the new value of u is x_m . The value of $\omega_m(\pi)$ for this new u equals $m\pi$, but such u is discontinuous and therefore not acceptable. We make amends: the region where the graph of ω_m trespasses the wall by more than

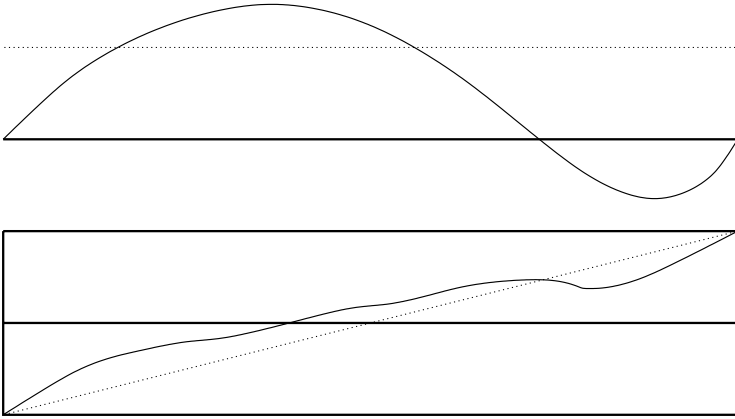

FIGURE 3. Graphs of u and x_m and their m -arguments

a prescribed tolerance is taken to x_m and in the region where the graph of ω_m lies strictly between the walls, u is unchanged. Hence, there is an open region in the domain where u assumes rather arbitrary values in order to preserve its continuity.

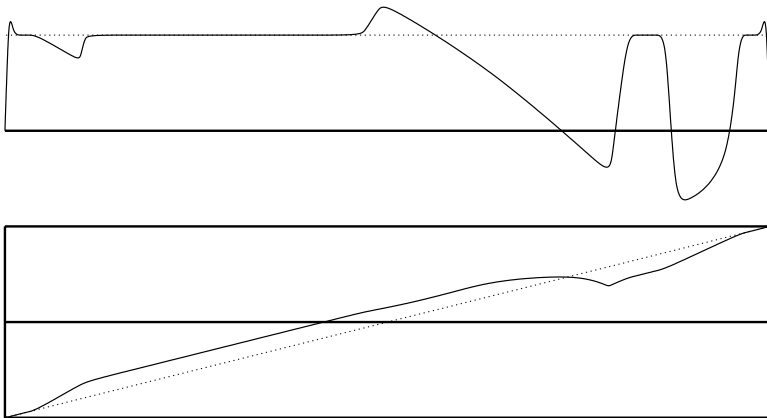

FIGURE 4. The function u gets squeezed

Similar results were previously obtained for the special case when f is a convex nonlinearity ([17], [3]). The trivial topology of each connected component $C_{2,D,m}$ then follows from the fact that each such set is a graph over the hyperplane in H_D^2 of functions orthogonal to $\sin t$.

6. The second order periodic case

Things get more complicated for the second order operator with periodic boundary conditions. As is well known, the associated linearizations do not necessarily have simple spectrum. Critical sets now are *not* submanifolds, and one has to be careful about nonregular points. Still, a description of the global geometry of the critical set is possible ([5], [6]).

For any smooth nonlinearity $f : \mathbb{R} \rightarrow \mathbb{R}$ denote by $F_{2,p}$ the differential operator

$$F_{2,p} : H_p^2 \rightarrow L^2$$

$$u \mapsto -u'' + f(u)$$

where $H_p^2 = H_p^2([0, 2\pi]; \mathbb{R}) = H^2(\mathbb{S}^1; \mathbb{R})$ and $L^2 = L^2([0, 2\pi]; \mathbb{R}) = L^2(\mathbb{S}^1; \mathbb{R})$. We are interested in the critical set $C_{2,p} \subset H_p^2$ of $F_{2,p}$. Again, the differential of $F_{2,p}$ is the Fredholm linear operator $DF_{2,p}(u)v = -v'' + f'(u)v$ of index 0.

Let $\Sigma_0 \subset \mathbb{R}^3$ be the plane $z = 0$ and, for $n > 0$, let Σ_n be the cone

$$x^2 + y^2 = \tan^2 z, \quad 2\pi n - \frac{\pi}{2} < z < 2\pi n + \frac{\pi}{2}$$

and $\Sigma = \bigcup_{n \geq 0} \Sigma_n$.

Theorem 7. *Let $f : \mathbb{R} \rightarrow \mathbb{R}$ be smooth function such that f' has isolated critical points and f' is surjective. Then the pair $(H_p^2, C_{2,p})$ is diffeomorphic to the pair $(\mathbb{R}^3 \times \mathbb{H}, \Sigma \times \mathbb{H})$.*

The set $C_{2,p}^* \subset C_{2,p}$ of potentials u for which *all* solutions v of

$$-v''(t) + f'(u(t))v(t) = 0$$

are periodic is the set of nonregular points. It follows from theorem 7 that $C_{2,p}^*$ is a submanifold of codimension 3, taken by the diffeomorphism mentioned in the theorem to the set vertices of the cones, i.e., to points of the form $((0, 0, 2\pi n), *) \in \mathbb{R}^3 \times \mathbb{H}$.

The proof of theorem 7 requires the topological study of the *monodromy map*. For $h \in L^2$, let $v_1, v_2 \in H^2([0, 2\pi]; \mathbb{R})$ be defined by

$$v_i''(t) = h(t)v_i(t), \quad v_1(0) = 1, v_1'(0) = 0, v_2(0) = 0, v_2'(0) = 1$$

and define $\tilde{\beta} : [0, 2\pi] \rightarrow G$ by $\tilde{\beta}(0) = I$ and

$$\tilde{\beta}(t) = \begin{pmatrix} v_1(t) & v_1'(t) \\ v_2(t) & v_2'(t) \end{pmatrix}$$

where $G = \widetilde{SL(2, \mathbb{R})}$ is the universal cover of $SL(2, \mathbb{R})$. Finally, define $\xi_\bullet : L^2 \rightarrow G$ by $\xi_\bullet(h) = \tilde{\beta}(2\pi)$. The map ξ_\bullet is not surjective: its image is an open set $G_+ \subset G$ diffeomorphic to \mathbb{R}^3 . The map ξ_\bullet is in a sense a projection:

Proposition 6.1. *There exists a smooth diffeomorphism $\Psi_k : G_+ \times \mathbb{H} \rightarrow L^2$ such that $\xi_\bullet \circ \Psi_k$ is the projection on the first coordinate.*

Further results in infinite dimensional topology are needed to handle the nonregular points.

7. The third order case

In the second order periodic case, the set $C_{2,p}^*$ plays a very important role. For the harder third order case, it is natural to start by considering its counterpart, the set $C_{3,p}^* \subset (H^3(\mathbb{S}^1))^2$ of pairs of potentials (h_0, h_1) for which *all* solutions v of

$$v'''(t) - h_1(t)v'(t) - h_0(t)v(t) = 0 \tag{†}$$

are periodic, i.e., satisfy

$$v(0) = v(2\pi), \quad v'(0) = v'(2\pi), \quad v''(0) = v''(2\pi).$$

For $(h_0, h_1) \in C_{3,p}^*$, let v_0, v_1, v_2 be the (fundamental) solutions of (†) with initial conditions

$$\begin{pmatrix} v_0 & v_1 & v_2 \\ v'_0 & v'_1 & v'_2 \\ v''_0 & v''_1 & v''_2 \end{pmatrix} (0) = I$$

and normalize:

$$\gamma(t) = \frac{1}{|(v_0(t), v_1(t), v_2(t))|} (v_0(t), v_1(t), v_2(t)).$$

A straightforward computation yields

$$\det(\gamma(0), \gamma'(0), \gamma''(0)) = 1, \quad \det(\gamma(t), \gamma'(t), \gamma''(t)) > 0 \text{ for all } t.$$

Conversely, a curve $\gamma : [0, 2\pi] \rightarrow \mathbb{S}^2$ is *locally convex* if $\det(\gamma(t), \gamma'(t), \gamma''(t)) > 0$ for all t . Notice that this implies $\gamma'(t) \neq 0$ for all t . Let X_I be the set of locally convex curves γ (with appropriate smoothness hypothesis) satisfying

$$\gamma(0) = \gamma(2\pi) = e_1, \quad \gamma'(0) = \gamma'(2\pi) = e_2, \quad \gamma^{(j)}(0) = \gamma^{(j)}(2\pi)$$

and let $X_I^1 \subset X_I$ be the set of curves γ with $\det(\gamma(0), \gamma'(0), \gamma''(0)) = 1$. Clearly, the inclusion $X_I^1 \subset X_I$ is a homotopy equivalence. The map just described from $C_{3,p}^*$ to X_I^1 is a diffeomorphism; we proceed to construct its inverse. Given $\gamma \in X_I^1$, set

$$r(t) = (\det(\gamma(t), \gamma'(t), \gamma''(t)))^{-1/3}$$

and $V(t) = r(t)\gamma(t)$. We then have $\det(V(t), V'(t), V''(t)) = 1$ for all t , which implies that the vector $V'''(t)$ is a linear combination of $V(t)$ and $V'(t)$. In other words, there exist unique real valued functions h_0 and h_1 with $V'''(t) = h_0(t)V(t) + h_1(t)V'(t)$, so that each coordinate of V is a periodic (fundamental) solution of (†) and the pair (h_0, h_1) belongs to $C_{3,p}^*$. Thus, $C_{3,p}^*$ is homotopy equivalent to X_I .

The space X_I has been studied, among others, by Little ([11]), B. Shapiro, M. Shapiro and Khesin ([21], [22], [20]). Little showed that X_I has three connected components which we shall call $X_{-1,c}$, X_1 and X_{-1} . One of the authors (S., [18])

established several results concerning the homotopy and cohomology of these components. It turns out that $X_{-1,c}$ is contractible and X_1 and X_{-1} are simply connected but not homotopically equivalent to finite CW-complexes. Also, $\pi_2(X_{-1})$ contains a copy of \mathbb{Z} and $\pi_2(X_1)$ contains a copy of \mathbb{Z}^2 . As for the cohomology, $H^n(X_1, \mathbb{R})$ and $H^n(X_{-1}, \mathbb{R})$ are nontrivial for all even n , $\dim H^{4n-2}(X_1, \mathbb{R}) \geq 2$ and $\dim H^{4n}(X_{-1}, \mathbb{R}) \geq 2$ for all positive n .

These results indicate that the topology of the critical set of third order operators is far more complicated than the lower order counterparts.

References

- [1] A. Ambrosetti and G. Prodi, *On the inversion of some differentiable maps between Banach spaces with singularities*, Ann. Mat. Pura Appl. **93** (1972), 231–246.
- [2] M. Berger and E. Podolak, *On the solutions of a nonlinear Dirichlet problem*, Ind. Univ. Math. J. **24** (1975), 837–846.
- [3] H. Bueno and C. Tomei, *Critical sets of nonlinear Sturm-Liouville operators of Ambrosetti-Prodi type*, Nonlinearity **15** (2002), 1073–1077.
- [4] D. Burghilea, N. Saldanha and C. Tomei, *Results on infinite-dimensional topology and applications to the structure of the critical set of nonlinear Sturm-Liouville operators*, J. Diff. Eq **188** (2003), 569–590.
- [5] D. Burghilea, N. Saldanha and C. Tomei, *The topology of the monodromy map of the second order ODE*, arXiv:math.CA/0507120.
- [6] D. Burghilea, N. Saldanha and C. Tomei, *The geometry of the critical set of periodic Sturm-Liouville operators*, in preparation.
- [7] V. Cafagna and F. Donati, *Un résultat global de multiplicité pour un problème différentiel non linéaire du premier ordre*, C. R. Acad. Sci. Paris Sér. **300** (1985), 523–526.
- [8] M. Calanchi and B. Ruf, *On the number of closed solutions for polynomial ODE's and a special case of Hilbert's 16th problem*, Advances in Diff. Equ. **7** (2002), 197–216.
- [9] P.T. Church, E.N. Dancer and J.G. Timourian, *The structure of a nonlinear elliptic operator*, Trans. Amer. Math. Soc. **338** no. 1 (1993), 1–42.
- [10] A. Lins Neto, *On the number of solutions of the equation $\frac{dx}{dt} = \sum_{j=0}^n a_j(t)x^j$, $0 \leq t \leq 1$, for which $x(0) = x(1)$* , Inventiones Math. **59** (1980), 67–76.
- [11] J.A. Little, *Nondegenerate homotopies of curves on the unit 2-sphere*, J. Differential Geometry **4** (1970), 339–348.
- [12] H.P. McKean and J.C. Scovel, *Geometry of some simple nonlinear differential operators*, Ann. Sc. Norm. Sup. Pisa Cl. Sci. (4) **13** (1986), 299–346.
- [13] I. Malta, N.C. Saldanha and C. Tomei, *The numerical inversion of functions from the plane to the plane*, Math. Comp. **65** (1996), 1531–1552.
- [14] I. Malta, N.C. Saldanha and C. Tomei, *Morin singularities and global geometry in a class of ordinary differential equations*, Top. Meth. in Nonlinear Anal. **10** no. 1 (1997), 137–169.

- [15] I. Malta, N.C. Saldanha and C. Tomei, *Regular level sets of averages of Nemytskiĭ operators are contractible*, J. Func. Anal. **143** (1997), 461–469.
- [16] B. Morin, *Formes canoniques de singularités d'une application différentiable*, C. R. Acad. Sc. Paris **260** (1965), 5662–5665 and 6503–6506.
- [17] B. Ruf, *Singularity theory and bifurcation phenomena in differential equations*, Topological Nonlinear Analysis II, Progr. in Nonlin. Diff. Equ. and Appl. 27, eds. M. Matzeu, A. Vignoli, Birkhäuser, 1997.
- [18] N. Saldanha, *Homotopy and cohomology of spaces of locally convex curves in the sphere*, arXiv:math.GT/0407410.
- [19] N. Saldanha and C. Tomei, *Functions from \mathbb{R}^2 to \mathbb{R}^2 : a study in nonlinearity*, arXiv:math.NA/0209097.
- [20] B. Shapiro and B. Khesin, *Homotopy classification of nondegenerate quasiperiodic curves on the 2-sphere*, Publ. Inst. Math. (Beograd) **66** (80) (1999), 127–156.
- [21] B. Shapiro and M. Shapiro, *On the number of connected components of nondegenerate curves on S^n* , Bull. of the AMS **25** (1991), 75–79.
- [22] M. Shapiro, *Topology of the space of nondegenerate curves*, Math. USSR **57** (1993), 106–126.
- [23] H. Whitney, *On singularities of mappings of Euclidean spaces I. Mappings of the plane into the plane*, Ann. Math. **62** (1955), 374–410.

Nicolau C. Saldanha and Carlos Tomei

Departamento de Matemática

PUC-Rio

R. Marquês de S. Vicente 225

Rio de Janeiro, RJ 22453-900

Brazil

e-mail: nicolau@mat.puc-rio.br

tomei@mat.puc-rio.br

URL: <http://www.mat.puc-rio.br/~nicolau/>

A Note on the Superlinear Ambrosetti–Prodi Type Problem in a Ball

P.N. Srikanth and Sanjiban Santra

Abstract. Using a careful analysis of the Morse indices of the solutions obtained by using the Mountain Pass Theorem applied to the associated Euler–Lagrange functional acting both on the full space $H_0^1(\Omega)$ and on its subspace $H_{0,r}^1(\Omega)$ of radially symmetric functions we prove the existence of non-radially symmetric solutions of a problem of Ambrosetti–Prodi type in a ball.

Mathematics Subject Classification (2000). 35J65, 35J20.

Keywords. Mountain Pass Theorem, non-radial solutions, Morse index, concentration.

1. Introduction

We consider the semi-linear elliptic problem

$$(P_t) \quad \begin{cases} -\Delta u = (u^+)^p - t\varphi_1 & \text{in } \Omega \\ u = 0 & \text{on } \partial\Omega \end{cases}$$

where $\Omega = \{x \in \mathbb{R}^n : |x| < 1\}$. φ_1 is the eigenfunction corresponding to the first eigenvalue λ_1 of $(-\Delta)$ with zero Dirichlet data on the boundary and normalized by taking $\varphi_1(0) = 1$. t is a real parameter. Due to requirements of the variational method used here, we have to restrict the values of the dimension n to $1 < n < 6$.

In [2], it has been proved that (S_t) with $g(u) = u^2$ admits a non-radially symmetric solution for large $t > 0$ even if Ω is a ball. It is also easy to see that the result in [2] follows if $g(u) = |u|^p$ where $p \in (1, \frac{n+2}{n-2})$ if $n \geq 3$ and $p \in (1, \infty)$ if $n = 2$. Motivated by the results in [2] it has been proved in [1] that (S_t) has a non-symmetric solution in Ω where Ω is a smooth bounded domain in \mathbb{R}^n where $p \in (1, \frac{n+2}{n-2})$ if $n \geq 3$ and $p \in (1, \infty)$ if $n = 2$:

$$(S_t) \quad \begin{cases} -\Delta u = g(u) - t\varphi_1 & \text{in } \Omega \\ u = 0 & \text{on } \partial\Omega \end{cases}$$

where $g(u) = |u|^p$. In [1] the method works for nonlinearity of the form $g(u) = a|u^+|^p + b|u^-|^p$ for $a > 0, b > 0$. It is not clear whether the method [1] works for a nonlinearity of the form $g(u) = (u^+)^p$ because of the estimate one needs to control the negative solution. In this note we conclude that the result in [2] holds for $g(u) = (u^+)^p$.

So our main results are the following.

Theorem 1. *For $t > 0$ sufficiently large, all the non-negative radial solutions of (P_t) have Morse index larger than 1.*

As a consequence of this theorem, we have

Corollary. *For $t > 0$ sufficiently large a solution of (P_t) in $H_{0,r}^1(\Omega)$ with Morse index 1 has to change sign.*

Theorem 2. *For $t > 0$ sufficiently large the radial solution of (P_t) has Morse index 1 in the space $H_{0,r}^1(\Omega)$ and has Morse index at least 2 on the whole space $H_0^1(\Omega)$.*

Theorem 3. *For $t > 0$ sufficiently large (P_t) has solutions which are not radially symmetric.*

2. Proofs of the Theorems

The regularity results imply that the $H_0^1(\Omega)$ -solutions obtained here are indeed classical solutions, and this fact will be used throughout the paper. Also note that if u is a positive solution of (P_t) then $u^+ = u$.

Remark 1. To start with, using this fact we obtain the following properties of the radial solutions of (P_t) . We recall that a radial solution ${}_t u$ of (P_t) satisfies the equation

$$-{}_t u_{rr} - \frac{(n-1){}_t u_r}{r} = ({}_t u^+)^p - t\varphi_1,$$

and boundary conditions ${}_t u_r(0) = {}_t u(1) = 0$.

- 1) Each non-negative radial solution of (P_t) has at most a finite number of points of maxima and minima.
- 2) At a point of maximum a_t of a non-negative radial solution ${}_t u$ we have ${}_t u^p(a_t) - t\varphi_1(a_t) \geq 0$. Also, there is an open interval (a_t, d_t) where ${}_t u^p(r) - t\varphi_1(r) > 0$.
- 3) At a point of minimum m_t of a non-negative radial solution ${}_t u$ we have ${}_t u^p(m_t) - t\varphi_1(m_t) \leq 0$. Also, there is an open interval (e_t, m_t) where ${}_t u^p(r) - t\varphi_1(r) < 0$.
- 4) The proofs of Theorem 1 and Corollary go in the same way as in [2] so we will not prove this in our note.
- 5) If u_0 is a negative solution to (P_t) , then we have

$$\begin{cases} -\Delta u = -t\varphi_1 & \text{in } \Omega \\ u = 0 & \text{on } \partial\Omega. \end{cases}$$

Hence the solution to this problem is $u_0 = -\frac{t\varphi_1}{\lambda_1}$ which is unique.

6) When the nonlinearity is u^2 , then one can easily show that

$$\|{}_t u^+\|_{L^\infty} \leq C\sqrt{t}$$

which is a consequence of the negative part satisfying

$$\|{}_t u^-\|_{L^\infty} \leq C\sqrt{t}.$$

However in the context of the problem we are discussing the negative part behaves like

$$\|{}_t u^-\|_{L^\infty} \sim t$$

which calls for a subtle argument to obtain the main result of the paper. In fact, this seems to be the main reason why the results of [1] do not seem to work for nonlinearities like $(u^+)^p$.

7) Since $n \leq 5$, the functional associated to the problem (P_t) is

$$I_t(u) = \frac{1}{2} \int_{\Omega} |\nabla u|^2 - \frac{1}{p+1} \int_{\Omega} (u^+)^{p+1} + t \int_{\Omega} \varphi_1 u, \forall u \in H_0^1(\Omega)$$

and it satisfies the Palais–Smale condition.

The strategy used to prove Theorem 1 consists in showing that any positive solution ${}_t u$ of (P_t) has Morse index at least two, for t large. This can be done by just considering three types of positive solutions:

Type I: ${}_t u$ has a unique maximum at 0.

Type II: ${}_t u$ has at least two maxima.

Type III: ${}_t u$ has a unique maximum at a point $a_t \in (0, 1)$.

Lemma 1: *Suppose ${}_t u$ is a positive radial solution of (P_t) having unique maximum at the origin, then for large t such a solution will have a high Morse index.*

Proof. Similar as in [2]. □

Note, by definition, if ${}_t u$ is a solution of (P_t) , its Morse index is given by the dimension of the space where the form below is negative definite, that is,

$$\langle -\Delta w - p({}_t u^+)^{p-1} w, w \rangle < 0, \quad w \in H_0^1(\Omega).$$

Since the linearized problem is given by

$$-\Delta(\cdot) = (p({}_t u^+)^{p-1})(\cdot)$$

it follows that, if the weight gets very large on an interval of fixed length, then the Morse index also gets large.

Remark 2. We have made no assumption $({}_t u^p - t\varphi_1)(0) \neq 0$. All we want in Lemma 1 is that “0” is the unique maximum. In the case $({}_t u^p - t\varphi_1)(0) = 0$, ${}_t u$ decreases near “0” can be seen by differentiating the equation

$$-{}_t u_{rrr}r - (n-1){}_t u_r = ({}_t u^p - t\varphi_1)r$$

to obtain ${}_t u_{rrrr}(0) < 0$ and ${}_t u_{rrr}(0) = 0$. Note ${}_t u_{rr}(0) = 0$ follows from $({}_t u^p - t\varphi_1)(0) = 0$. This implies ${}_t u^p - t\varphi_1 > 0$ in an interval $(0, d_t)$.

Lemma 2. *If ${}_t u \geq 0$ is a radial solution of (P_t) for some $t > 0$ with more than one maximum, then its Morse index is at least 2 on the radial space.*

Proof. There are two possibilities. A) The solution has precisely two maxima: 0 and $a_t > 0$; B) The solution has two maxima $0 < a_{t_1} < a_{t_2} < 1$, and eventually more. We assume that those are the two largest ones.

The proof in either case follows in the same way as in [2]. The basic fact is to use the function $F(r) := {}_t u^p - t\varphi_1$, and noting that

$$-\Delta F(r) = (p_t u^{p-1})F(r) - p(p-1)_t u_r^2 {}_t u^{p-2} - t\lambda_1 \varphi_1$$

and observing also that $p(p-1)_t u_t^{p-1} u_r^2 + t\lambda_1 \varphi_1 > 0, \forall r \in [0, 1)$. □

Lemma 3. *Suppose that for all t large there exists a radial positive solution ${}_t u$ in $(0, 1)$ of (P_t) , with Morse Index 1 on the radial space $H_{0,r}^1(\Omega)$ with $({}_t u^p - t\varphi_1)(0) \leq 0$, then $a_t \rightarrow 1$ as $t \rightarrow \infty$, where a_t is the unique maximum in $(0, 1)$.*

Proof. From the fact that there is a unique maximum, we have ${}_t u_r > 0$ in $(0, a_t)$ and ${}_t u_r \leq 0$ in $(a_t, 1)$. We denote by b_t the unique point in $(0, a_t)$ where $({}_t u^p - t\varphi_1) = 0$, i.e., $({}_t u^p - t\varphi_1)(b_t) = 0$. The uniqueness of b_t follows from the fact that ${}_t u$ is increasing in $([0, a_t)$ whereas φ_1 is decreasing in $(0, 1)$. The proof of this lemma is essentially contained in Lemma 1, and similar to [2]. □

Remark 3. Let b_t be the point in $(0, a_t)$ as specified in the proof of Lemma 3. If $b_t = 0, \forall t$ large, we see easily that the Morse index cannot be 1. It is also clear from Lemma 3, since $a_t \rightarrow 1$, one should have that $b_t \rightarrow 1$ as well in order to maintain Morse index 1 in the context of the positive solutions we are discussing. We will now prove that $b_t \rightarrow 1$ will lead to a contradiction, thus completing the proof of Theorem 1.

Lemma 4. *Suppose that for all t large there exists a radial positive solution ${}_t u$ in $(0, 1)$ of (P_t) , with Morse index 1 on the radial space with $({}_t u^p - t\varphi_1)(0) < 0$. Then b_t cannot converge to 1 as $t \rightarrow \infty$, where b_t is the unique point in $(0, a_t)$ such that $({}_t u^p - t\varphi_1)(b_t) = 0$, a_t being the unique maximum in $(0, 1)$.*

Proof. See [2]. □

Proof of Theorem 2. By Theorem 1, we know that the solution obtained by Mountain Pass in $H_{0,r}^1(\Omega)$ has to change sign. Note that there cannot be more than one positive part if the Morse index is 1. Note that the fact that each positive part contributes to the Morse index by 1 in the radial space follows from

$$\langle -\Delta u - (pu^{p-1})u, u \rangle_{H_{0,r}^1(a_i, b_i)} = - \int_{a_i}^{b_i} (u^p + t\varphi_1)u < 0$$

in each (a_i, b_i) , where (a_i, b_i) are disjoint intervals of positivity of $u, u|_{(a_i, b_i)} \in H_{0,r}^1(a_i, b_i)$. In this context, due to the above facts we need to look at two types of solutions.

Type IV: the radial solution ${}_t u$ has a (unique) positive maximum at 0 and a unique negative minimum at $a_t \in (0, 1)$.

Type V: the radial solution ${}_t u$ has a (unique) negative minimum at 0 and a unique positive maximum at $a_t \in (0, 1)$.

All other possibilities are covered by reasonings similar to the ones used to handle Types I through V. We proceed now with the proof of Theorem 2 by showing Lemmas 5, Proposition 1 and Lemma 6.

Lemma 5. *Suppose ${}_t u$ is a radial solution of (P_t) with ${}_t u(0) > 0$ and with a negative part. Then ${}_t u$ has Morse index at least 2 on the space $H_0^1(\Omega)$.*

Proof. Note that, under the assumptions of this lemma, a typical solution is of Type IV. Dropping the prefix “ t ” for the solution we have that it satisfies the equation i.e.

$$\begin{cases} -\Delta u &= (u^+)^p - t\varphi_1 & \text{in } \Omega \\ u &= 0 & \text{on } \partial\Omega \end{cases} \tag{1}$$

In the course of our proof, we will discuss the case $\Omega \subset \mathbb{R}^2$ (see Remark 4 for the general case), just to make the idea more explicit. Denoting the coordinates by $(x, y) = (r \cos \theta, r \sin \theta)$, and differentiating (1) with respect to x and writing $w = u_r \cos \theta$, we see that w satisfies

$$\begin{cases} -\Delta w &= (pu^{p-1})w - t\varphi_{1,r} \cos \theta & \text{in } B(0, d_t) \\ -\Delta w &= -t\varphi_{1,r} \cos \theta & \text{in } B(0, a_t) - B(0, d_t) \\ w &= 0 & \text{on } \partial B(0, a_t) \end{cases}$$

Note that $u_r \leq 0$ in $(0, a_t)$, where a_t is the first minimum of u and $u(d_t) = 0$. Since $\varphi_{1r} \leq 0$, we have

$$\langle -\Delta w_0 - p(u^+)^{p-1}w_0, w_0 \rangle < 0 \quad H_0^1(\Omega)$$

where w_0 is defined by w in $B(0, a_t)$ and zero elsewhere. Note that u^+ contributes to the Morse index and w_0 also contributes to the Morse Index and w_0 and u^+ are orthogonal. In fact the Morse index of u is at least 2. In fact the Morse index of u is at least 3 since $w_1 = u_r \sin \theta$ will play the same role as w .

Hence the lemma. □

Remark 4. It is clear $u_{x_i} (i = 1, \dots, n)$ will work exactly like $u_r \cos \theta$ if we are in higher dimensions, leading to Morse index being $(n + 1)$.

Remark 5. In view of Theorem 1 and Lemma 5 it is clear that Theorem 2 will follow if we can show that radial solutions with ${}_t u(0) < 0$ and having a unique zero in $(0, 1)$ has Morse index at least 2 on the whole space for t large. A typical solution we need to consider is of Type V. Note that if ${}_t u(0) < 0$ and has two nodal zeros, then arguments as the ones used in Lemma 5 would lead to a high Morse index on the whole space.

Let d_t denote the unique zero of ${}_t u$ in $(0, 1)$, a_t the point of maximum and b_t is the unique point in (d_t, a_t) such that ${}_t u^p(b_t) - t\varphi_1(b_t) = 0$.

Remark 6. If ${}_t u$ denotes a solution as discussed in Remark 5, we have that $\|{}_t u^-\|_{L^\infty} \leq t$ if ${}_t u_r \geq 0$ in $[0, a_t]$, where ${}_t u^- = \max(-{}_t u, 0)$.

It is easy to show that $\|{}_t u^-\|_{L^\infty} \leq t$. We now proceed to show that $\|u^+\|_{L^\infty} \leq C t^{\frac{2}{p+1}}$ for C independent of t , for all solutions under consideration which is a major cause of difficulty.

Proposition 1. *Suppose ${}_t u$ is a radial solution of (P_t) for $t > 0$ with ${}_t u(0) < 0$ and with ${}_t u$ changing sign at a unique point, say d_t in $(0, 1)$ with ${}_t u > 0$ in $(d_t, 1)$, having a unique maximum “ a_t ” and ${}_t u_r \geq 0$ in $(0, a_t)$. Then there exists $C > 0$ independent of t such that*

$$\|{}_t u^+\|_{L^\infty} \leq C t^{\frac{2}{p+1}}. \tag{2}$$

Remark 7. In the context of Theorem 2, which is our main goal, it is clear, from earlier discussions, that now we need just to consider solutions satisfying hypothesis of Proposition 1. That is, solutions starting with ${}_t u(0) < 0$ and having a unique positive maximum at some point “ a_t ” with ${}_t u_r \geq 0$ in $[0, a_t]$. Note that arguments similar to Lemma 5 would imply a higher Morse index if ${}_t u_r < 0$ in some subinterval of $[0, a_t]$. Also as observed earlier two positive maxima would make the solutions to have higher Morse index on the radial space itself. Also ${}_t u(0) > 0$ has already been taken care through Lemma 5.

Proof of Proposition 1. Similar to [2]. □

Remark 8. In the context of solutions discussed in Proposition 1 it is clear that arguments of Lemma 3 are applicable and that $a_t \rightarrow 1$ as $t \rightarrow \infty$ as long as we assume ${}_t u$ has Morse index 1 on the Radial space.

Lemma 6. *Let ${}_t u$ be a solution of (P_t) with Morse index 1 on the radial space and satisfying the hypothesis of Proposition 1, then $d_t \rightarrow 1$ as $t \rightarrow \infty$.*

Proof. Similar as [2]. □

Proof of Theorem 2 (completed). In order to finish the proof of Theorem 2, we have just to use the previous lemmas to show that a radial solution of Type V, has Morse index higher than 1 in the full space $H_0^1(\Omega)$. This is done next. We will discuss the proof $\Omega \subset \mathbb{R}^2$, and $\Omega \subset \mathbb{R}^n$, $n \geq 3$, separately.

Recall that we are working in a situation where the solution is like in Type V. Let us first discuss the case when $\Omega \subset \mathbb{R}^n$, when $n \geq 3$.

Let ${}_t w = {}_t u(r)(x_1 + x_2 + \dots + x_n)$, then

$$\Delta_t w = (x_1 + x_2 + \dots + x_n)\Delta_t u - 2 \sum_{i=1}^n {}_t u_{x_i}.$$

Hence

$$-\Delta_t w = (x_1 + x_2 + \dots + x_n)({}_t u^p - t\varphi_1) - 2 \sum_{i=1}^n {}_t u_{x_i}.$$

Then ${}_t w$ satisfies on $(d_t, 1)$ the equation

$$\begin{cases} -\Delta_t w &= p({}_t u^{p-1})_t w - (p-1)_t u^p(x_1 + x_2 + \dots + x_n) \\ &\quad - t(x_1 + x_2 + \dots + x_n)\varphi_1 - 2\sum_{i=1}^n {}_t u_{x_i} \text{ in } \Omega_{d_t} \\ {}_t w &= 0 \text{ on } \partial\Omega_{d_t} \end{cases}$$

where $\Omega_{d_t} = \{r : d_t < r < 1\}$. Thus

$$\begin{aligned} \langle -\Delta_t w - p({}_t u^{p-1})_t w, w \rangle &= -(p-1) \int_{\Omega} (x_1 + x_2 + \dots + x_n)^2 {}_t u^{p+1} dx \\ &\quad - t \int_{\Omega} (x_1 + x_2 + \dots + x_n)_t^2 u \varphi_1 dx \\ &\quad - 2 \int_{\Omega} (x_1 + x_2 + \dots + x_n)_t u \sum_{i=1}^n {}_t u_{x_i} dx \end{aligned}$$

i.e.

$$\langle -\Delta_t w - p({}_t u^{p-1})_t w, {}_t w \rangle = -(p-1) \int_{\Omega} r^2 {}_t u^{p+1} - t \int_{\Omega} r^2 {}_t u \varphi_1 + n \int_{\Omega} {}_t u^2.$$

Now let ${}_t u(r) > 0$ in Ω_{d_t} . In order to prove that the solution has Morse index higher than 1 on the whole space, it is enough to show that the function ${}_t F(r) = -(p-1)_t u^p r^2 - t\varphi_1 r^2 + n {}_t u(r)$ is negative in $(d_t, 1)$. We will show this to be the case for t large.

By Lemma 6 we know that $d_t \rightarrow 1$. Hence taking $t > 0$ large enough we can assume $r^2 \geq \frac{3}{4}$ in the region of interest. Observe that ${}_t F(r) < 0$ if ${}_t u^{p-1}(r) \geq \frac{4n}{3(p-1)}$. Hence ${}_t F(r) \geq 0$ can occur only if $0 < {}_t u^{p-1}(r) < \frac{4n}{3(p-1)}$. Now note that ${}_t F(d_t) < 0$ and ${}_t F(1) = 0$.

First we claim that

$$|\lambda_1 {}_t u_r(r)| \leq t |\varphi_{1,r}(r)| \quad \forall r \in (d_t, a_t). \tag{3}$$

Proof of the claim. We have

$$-({}_t u_r r^{n-1})_r = (({}_t u^+)^p - t\varphi_1) r^{n-1},$$

and integrating from 0 to s , where $s \leq a_t$, we have

$$-\int_0^s ({}_t u_r r^{n-1})_r dr = \int_0^s ({}_t u^+)^p r^{n-1} dr - t \int_0^s \varphi_1 r^{n-1} dr$$

Hence we have

$$\begin{aligned} -s^{n-1} {}_t u_r(s) &= \int_{d_t}^s {}_t u^p r^{n-1} dr - t \int_0^s \varphi_1 r^{n-1} dr \\ \Rightarrow s^{n-1} {}_t u_r(s) &= t \int_0^s \varphi_1 r^{n-1} dr - \int_{d_t}^s {}_t u^p r^{n-1} dr \\ \Rightarrow s^{n-1} {}_t u_r(s) &\leq -\frac{t}{\lambda_1} s^{n-1} \varphi_{1,r}(s). \end{aligned}$$

Thus we have

$$\lambda_1 |{}_t u_r(r)| \leq t |\varphi_{1,r}(r)|$$

as ${}_t u_r(r) \geq 0$ in (d_t, a_t) .

Note that in this case $p < \frac{n+2}{n-2}$ and $\lambda_1 > \frac{n\pi^2}{4}$. For $r \in (d_t, a_t)$ and $0 < {}_t u^{p-1}(r) < \frac{4n}{3(p-1)}$ we have

$$\begin{aligned} \frac{{}_t F_r(r)}{t} &= \frac{-p(p-1) {}_t u_r(r) {}_t u^{p-1}(r) r^2 - 2 {}_t u^p(r) r - t \varphi_{1,r} r^2 - 2t \varphi_1 r + n {}_t u_r(r)}{t} \\ \Rightarrow \frac{{}_t F_r(r)}{t} &= -p(p-1) \frac{{}_t u_r(r)}{t} {}_t u^{p-1}(r) r^2 + |\varphi_{1,r}(r)| r^2 + n \frac{{}_t u_r(r)}{t} \\ &\quad - 2 \frac{{}_t u^p(r) r}{t} - 2 \varphi_1 r \end{aligned} \tag{4}$$

Now let us look to what happens to ${}_t F_r(1)$. We have ${}_t F_r(1) = -n |{}_t u_r(1)| + t |\varphi_{1r}(1)|$. Hence we have ${}_t F_r(1) = t \{-\frac{n |{}_t u_r(1)|}{t} + |\varphi_{1r}(1)|\}$. Dropping the prefix t for the time being, we have

$$-(r^{n-1} u_r(r))_r = ((u^+)^p - t \varphi_1) r^{n-1}$$

in $(0, a_t)$.

Multiplying both sides by $r^{n-1} u_r$ and integrating between 0 to a_t we have

$$\begin{aligned} - \int_0^{a_t} (r^{n-1} u_r(r))_r (r^{n-1} u_r(r)) dr &= \int_{d_t}^{a_t} u^p u_r r^{2n-2} dr - t \int_0^{a_t} u_r \varphi_1 r^{2n-2} dr \\ - \int_0^{a_t} (r^{n-1} u_r)_r (r^{n-1} u_r) dr &= \frac{1}{p+1} \int_{d_t}^{a_t} (u^{p+1})_r r^{2n-2} dr - t \int_0^{a_t} u_r \varphi_1 r^{2n-2} dr \\ \Rightarrow -\frac{1}{2} \int_0^{a_t} ((r^{n-1} u_r)^2)_r dr &= \frac{1}{p+1} u^{p+1}(a_t) a_t^{2n-2} - \frac{2n-2}{p+1} \int_{d_t}^{a_t} u^{p+1} r^{2n-3} dr \\ &\quad - t \int_0^{a_t} u_r \varphi_1 r^{2n-2} dr \\ \Rightarrow 0 &= -\frac{1}{p+1} u^{p+1}(a_t) a_t^{2n-2} + \frac{2n-2}{p+1} \int_{d_t}^{a_t} u^{p+1} r^{2n-3} dr \\ &\quad + t \int_0^{a_t} u_r \varphi_1 r^{2n-2} dr. \end{aligned} \tag{5}$$

Again we have in $(a_t, 1)$

$$-(r^{n-1} u_r(r))_r = (u^p - t \varphi_1) r^{n-1}.$$

Multiplying both sides by $r^{n-1} u_r$ and integrating between a_t to 1 we have

$$- \int_{a_t}^1 (r^{n-1} u_r)_r (r^{n-1} u_r) dr = \frac{1}{p+1} \int_{a_t}^1 (u^{p+1})_r r^{2n-2} dr - t \int_{a_t}^1 u_r \varphi_1 r^{2n-2} dr$$

$$\begin{aligned}
 \Rightarrow -\frac{1}{2} \int_{a_t}^1 ((r^{n-1}u_r)^2)_r dr &= -\frac{1}{p+1}u^{p+1}(a_t)a_t^{2n-2} - \frac{2n-2}{p+1} \int_{a_t}^1 u^{p+1}r^{2n-3} dr \\
 &\quad -t \int_{a_t}^1 u_r \varphi_1 r^{2n-2} dr \\
 \Rightarrow -\frac{u_r^2(1)}{2} &= -\frac{1}{p+1}u^{p+1}(a_t)a_t^{2n-2} - \frac{2n-2}{p+1} \int_{a_t}^1 u^{p+1}r^{2n-3} dr \\
 &\quad -t \int_{a_t}^1 u_r \varphi_1 r^{2n-2} dr \\
 \Rightarrow \frac{u_r^2(1)}{2} &= \frac{1}{p+1}u^{p+1}(a_t)a_t^{2n-2} + \frac{2n-2}{p+1} \int_{a_t}^1 u^{p+1}r^{2n-3} dr \\
 &\quad +t \int_{a_t}^1 u_r \varphi_1 r^{2n-2} dr \tag{6}
 \end{aligned}$$

Adding (5) and (6) we have

$$\frac{u_r^2(1)}{2} = \frac{2n-2}{p+1} \int_{a_t}^1 u^{p+1}r^{2n-3} dr + t \int_{a_t}^1 u_r \varphi_1 r^{2n-2} dr + t \int_0^{a_t} u_r \varphi_1 r^{2n-2} dr.$$

Hence we have

$$\frac{u_r^2(1)}{2} \leq \frac{2n-2}{p+1} \int_{a_t}^1 u^{p+1}r^{2n-3} dr + t \int_0^{a_t} u_r \varphi_1 r^{2n-2} dr. \tag{7}$$

Note that we have $r^{n-1}|\varphi_{1r}(r)|$ is an increasing function and $\int_0^1 r^{n-1}\varphi_1 dr = \frac{|\varphi_{1r}(1)|}{\lambda_1}$.

Hence for large t , (7) yields

$$\frac{u_r^2(1)}{2t^2} \leq \frac{|\varphi_{1r}(1)|}{\lambda_1} \int_0^{a_t} r^{n-1}\varphi_1 dr$$

$$\frac{\lambda_1}{\sqrt{2}} \left| \frac{u_r(1)}{t} \right| \leq |\varphi_{1r}(1)|$$

$$\frac{\pi^2 n}{4\sqrt{2}} \left| \frac{u_r(1)}{t} \right| \leq |\varphi_{1r}(1)|$$

Thus we have

$$n \left| \frac{u_r(1)}{t} \right| < |\varphi_{1r}(1)|.$$

So we have ${}_tF_r(1) > 0$. Hence ${}_tF(r) < 0$ in a neighborhood of 1.

Now we are required to prove that ${}_tF_r(r) > 0$ for $t \gg 0$ whenever $0 < {}_t u^{p-1}(r) \leq \frac{4n}{3(p-1)}$ and $r \in (a_t, 1)$.

Dropping the prefix t for the time being (for the sake of simplicity). In $(a_t, 1)$ we have

$$-(r^{n-1}u_r)_r = (u^p - t\varphi_1)r^{n-1}$$

Multiplying the above equation by $r^{n-1}u_r$ and integrating from a_t to r ($r > a_t$), we have

$$\begin{aligned} -\int_{a_t}^r (s^{n-1}u_s)_s (s^{n-1}u_s) ds &= \frac{1}{p+1} \int_{a_t}^r (u^{p+1})_s s^{2n-2} ds - t \int_{a_t}^r u_s \varphi_1 s^{2n-2} ds \\ -\frac{1}{2} \int_{a_t}^r ((s^{n-1}u_s)^2)_s ds &= \frac{1}{p+1} u^{p+1}(r) r^{2n-2} - \frac{1}{p+1} u^{p+1}(a_t) a_t^{2n-2} \\ &\quad - \frac{2n-2}{p+1} \int_{a_t}^r u^{p+1} s^{2n-3} ds - t \int_{a_t}^r u_s \varphi_1 s^{2n-2} ds \\ -\frac{1}{2} (r^{n-1}u_r)^2(r) &= \frac{1}{p+1} u^{p+1}(r) r^{2n-2} - \frac{1}{p+1} u^{p+1}(a_t) a_t^{2n-2} \\ &\quad - \frac{2n-2}{p+1} \int_{a_t}^r u^{p+1} s^{2n-3} ds - t \int_{a_t}^r u_s \varphi_1 s^{2n-2} ds \\ \frac{1}{2} r^{2n-2} u_r^2(r) &= -\frac{1}{p+1} u^{p+1}(r) r^{2n-2} + \frac{1}{p+1} u^{p+1}(a_t) a_t^{2n-2} \\ &\quad + \frac{2n-2}{p+1} \int_{a_t}^r u^{p+1} s^{2n-3} ds + t \int_{a_t}^r u_s \varphi_1 s^{2n-2} ds. \end{aligned} \tag{8}$$

Adding (5) and (8) we have

$$\begin{aligned} \frac{1}{2} r^{2n-2} u_r^2(r) &= -\frac{1}{p+1} u^{p+1}(r) r^{2n-2} + \frac{2n-2}{p+1} \int_{a_t}^r u^{p+1} s^{2n-3} ds \\ &\quad + t \int_{a_t}^r u_s \varphi_1 s^{2n-2} ds + t \int_0^{a_t} u_s \varphi_1 s^{2n-2} ds. \end{aligned}$$

Hence we have

$$\frac{1}{2} r^{2n-2} u_r^2(r) \leq \frac{2n-2}{p+1} \int_{a_t}^r u^{p+1} s^{2n-3} ds + t \int_0^{a_t} u_s \varphi_1 s^{2n-2} ds$$

i.e. for large t we have

$$\frac{1}{2} r^{2n-2} u_r^2(r) \leq t \int_0^{a_t} u_s \varphi_1 s^{2n-2} ds$$

$$\frac{1}{2} r^{2n-2} u_r^2(r) \leq \frac{t^2}{\lambda_1} a_t^{n-1} |\varphi_1(a_t)| \int_0^r s^{n-1} \varphi_1 ds$$

$$\Rightarrow \frac{1}{2} r^{2n-2} u_r^2(r) \leq \frac{t^2}{\lambda_1^2} r^{2n-2} |\varphi_{1r}(r)|^2$$

$$\begin{aligned} &\Rightarrow \frac{\lambda_1}{\sqrt{2}} \left| \frac{u_r(r)}{t} \right| \leq |\varphi_{1r}(r)| \\ &\Rightarrow \frac{4n}{3} \left| \frac{u_r(r)}{t} \right| < |\varphi_{1r}(r)|. \end{aligned}$$

Now we have for $r \in (a_t, 1)$

$$\frac{{}_tF_r(r)}{t} = -\frac{p(p-1){}_tu_r(r)}{t} {}_tu^{p-1}(r)r^2 - p\frac{{}_tu^p(r)r}{t} - \varphi_{1,r}r^2 - 2\varphi_{1r} + n\frac{{}_tu_r(r)}{t}.$$

For large t we have

$$\frac{{}_tF_r(r)}{t} \geq p(p-1) \left| \frac{{}_tu_r(r)}{t} \right| {}_tu^{p-1}(r)r^2 > 0.$$

Hence ${}_tF_r(r) > 0$. Hence ${}_tF(r) < 0$, $r \in (a_t, 1)$ for large t .

Now we have to show that ${}_tF(r) < 0$, $r \in (d_t, a_t)$.

Note that ${}_tF_r(d_t) > 0$ and ${}_tF_r(1) > 0$ which implies ${}_tF(r)$ is increasing in a neighborhood of d_t and 1. Hence if ${}_tF$ has a strict zero in $(d_t, 1)$, then it must have at least two zeros in $(d_t, 1)$. We claim that this cannot happen.

If possible, let there exist $r_t \in (d_t, a_t)$ such that ${}_tF(r_t) = 0$. Then we claim that $(1 - r_t) \leq \frac{C}{t}$. Since $0 < {}_tu^{p-1}(r) < \frac{4n}{3(p-1)}$ we have,

$$\begin{aligned} -(p-1){}_tu^p(r_t)r_t^2 - t\varphi_1(r_t)r_t^2 + {}_tu(r_t) &= 0 \\ (p-1){}_tu^p(r_t)r_t^2 + t\varphi_1(r_t)r_t^2 &= {}_tu(r_t) \\ \varphi_1(r_t) &\leq \frac{C}{t}. \end{aligned}$$

Hence we have by the mean value theorem

$$\varphi_1(1) - \varphi_1(r_t) = \varphi_{1,r}(\xi_t)(1 - r_t)$$

for some $\xi_t \in (r_t, 1)$ i.e we have $(1 - r_t) \leq \frac{C}{t}$.

Now we claim that $\frac{{}_tu_r(r_t)}{t}$ can be made as small as we wish.

If $r_t \in (d_t, a_t)$, we have

$$-(r^{n-1}{}_tu_r)_r = ({}_tu^p - t\varphi_1)r^{n-1}.$$

Integrating from r_t to a_t , we have

$$\begin{aligned} -\int_{r_t}^{a_t} (r^{n-1}{}_tu_r)_r dr &= \int_{r_t}^{a_t} {}_tu^p r^{n-1} dr - t \int_{r_t}^{a_t} \varphi_1 r^{n-1} dr \\ r_t^{n-1}{}_tu_r(r_t) &= \int_{r_t}^{a_t} {}_tu^p r^{n-1} dr - t \int_{r_t}^{a_t} \varphi_1 r^{n-1} dr \\ &\Rightarrow \frac{{}_tu_r(r_t)}{t} \rightarrow 0 \end{aligned}$$

as $t \rightarrow \infty$. Hence we have ${}_tF_r(r_t) > 0$ for large t which is a contradiction. Hence ${}_tF(r) < 0, \forall r \in (d_t, 1)$.

Now we discuss the case when $\Omega \subset \mathbb{R}^2$.

Let ${}_t w(x, y)$ be defined by

$${}_t w(x, y) = {}_t u(r) \cos \theta.$$

Then ${}_t w$ satisfies on $(d_t, 1)$ the equation

$$\begin{cases} -\Delta {}_t w &= (p {}_t u^{p-1})_t w - (p - 1)_t u^p \cos \theta - t\varphi_1 \cos \theta + \frac{{}_t u}{r^2} \cos \theta \text{ in } \Omega_{d_t} \\ {}_t w &= 0 \text{ on } \partial\Omega_{d_t} \end{cases}$$

where $\Omega_{d_t} = \{r : d_t < r < 1\}$ the annular domain.

Note that ${}_t u(r) > 0$ in Ω_{d_t} . In order to prove that the solution has a Morse index higher than 1 on the whole space, it is enough to prove that the function ${}_t F(r)$ defined by

$${}_t F(r) = -(p - 1)_t u^p(r)r^2 - t\varphi_1(r)r^2 + {}_t u(r)$$

is negative in $(d_t, 1)$. We will show this to be the case for t large.

Similar as above ${}_t F(r)$ can only occur if $0 < {}_t u(r) < \frac{4n}{3(p-1)}$. We claim that ${}_t F(r) < 0, \forall r \in (d_t, 1)$.

Note that from (4), ${}_t F_r(d_t) > 0$ and ${}_t F_r(1) < 0$. Hence ${}_t F(r)$ is increasing in a neighborhood of d_t and 1, it now follows that if ${}_t F$ has a strict zero in $(d_t, 1)$, then it must have at least two zeros in $(d_t, 1)$.

If possible, let there exist $r_t \in (d_t, 1)$ such that ${}_t F(r_t) = 0$. Then we claim that $(1 - r_t) \leq \frac{C}{t}$. Since $0 < {}_t u^{p-1}(r) < \frac{4n}{3(p-1)}$ we have

$$\begin{aligned} -(p - 1)_t u^p(r_t)r_t^2 - t\varphi_1(r_t)r_t^2 + {}_t u(r_t) &= 0 \\ (p - 1)_t u^p(r_t)r_t^2 + t\varphi_1(r_t)r_t^2 &= {}_t u(r_t) \\ \Rightarrow \varphi_1(r_t) &\leq \frac{C}{t}. \end{aligned}$$

Hence we have by mean value theorem

$$\varphi_1(1) - \varphi_1(r_t) = \varphi_{1r}(\xi_t)(1 - r_t)$$

for some $\xi_t \in (r_t, 1)$ i.e we have $(1 - r_t) \leq \frac{C}{t}$.

Now we claim that $\frac{{}_t u_r(r_t)}{t}$ can be made as small as we wish.

If $r_t \in (d_t, 1)$ we have

$$-(r_t u_r)_r = ({}_t u^p - t\varphi_1)r.$$

Integrating from r_t to a_t , we have

$$\begin{aligned} -\int_{r_t}^{a_t} (r_t u_r)_r dr &= \int_{r_t}^{a_t} {}_t u^p r dr - t \int_{r_t}^{a_t} \varphi_1 r dr \\ r_t u_r(r_t) &= \int_{r_t}^{a_t} {}_t u^p r dr - t \int_{r_t}^{a_t} \varphi_1 r dr \\ &\Rightarrow \frac{{}_t u_r(r_t)}{t} \rightarrow 0 \end{aligned}$$

as $t \rightarrow \infty$. Hence we have ${}_tF_r(r_t) > 0$ for large t , which is a contradiction.

Similar is the case when $r_t \in (a_t, 1)$. Hence Theorem 2 follows. \square

Proof of Theorem 3. The functional associated to (P_t) is

$$I_t(u) = \frac{1}{2} \int_{\Omega} |\nabla u|^2 - \frac{1}{p+1} \int_{\Omega} (u^+)^{p+1} + t \int_{\Omega} \varphi_1 u$$

on $H_0^1(\Omega)$. From Remark 1, it follows that the negative solution u_0 is unique and is a strict local minimum for the functional I_t . Also note that the functional is unbounded below and hence it satisfies all the conditions of Mountain Pass Theorem and if $I_t(u_0) = c_0$ and hence there exist a critical level $c > c_0$ as a consequence of the Mountain Pass theorem. Also it is clear that I_t satisfies all the hypotheses of Theorem 10.2 of [5] (see page 222 and Theorem 5.1 of [3]), and hence at a level c there exist a solution u of (P_t) with Morse index less than or equal to 1. If this solution is non-radial, then we are done. On the other hand, if this solution is radial, since $I_t(u_0) = c > c_0, u \neq u_0$ and u cannot be negative. Hence it has a positive part. This implies u has Morse index 1 on the radial space and hence the solution we are analyzing has to maintain Morse index 1 on the whole space. However, Theorem 2 implies such a solution has Morse Index at least 2 on the whole space. Then it implies that u has to be non-radial. Hence the theorem. \square

Acknowledgement. The second author acknowledges the partial support received from CSIR, India during the course of this work.

References

- [1] E.N. Dancer and Yan Shusen, Multiplicity and Profile of the changing sign solutions for an Elliptic Problem of Ambrosetti-Prodi type, preprint.
- [2] D.G. deFigueiredo, P.N. Srikanth and Santra Sanjiban, Non-radially Symmetric Solutions for a Superlinear Ambrosetti-Prodi Type Problem in a Ball, *Communications in Contemporary Mathematics*, to appear.
- [3] I. Ekeland and N. Ghoussoub, Selected new aspects of the calculus of variation in the large, *Bull. of the AMS* **39** (2002), 207–265.
- [4] G. Fang and N. Ghoussoub, Morse-Type Information on Palais–Smale sequences obtained by Min-Max Principles, *Communications in Pure and Applied Mathematics* **47** (1994), 1593–1653.
- [5] N. Ghoussoub, Duality and Perturbation Methods in Critical Point Theory, *Cambridge Tracts in Mathematics*, **107**, Cambridge University Press.

P.N. Srikanth
TIFR Centre
P.B. 1234
IISc Campus
Bangalore 560 012
India
e-mail: srikanth@math.tifrbng.res.in

Sanjiban Santra
Department of Mathematics
Indian Institute of Science
Bangalore 560 012
India
e-mail: sanjiban@math.iisc.ernet.in